

Kitchen Cart Cabinet

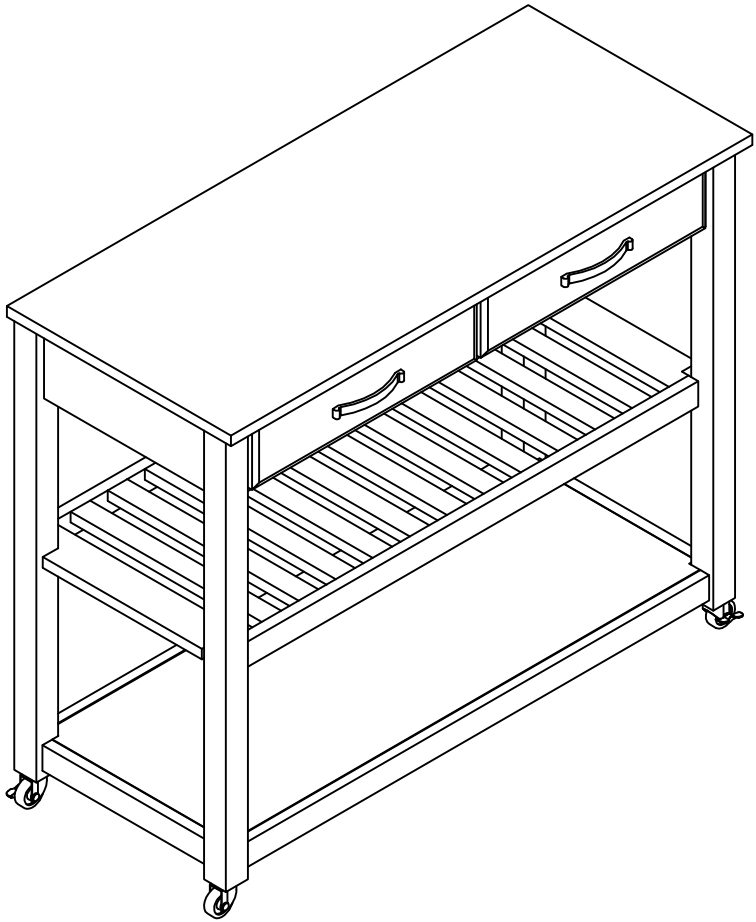







Congratulations! You have purchased a stylish piece of our furniture. We strive to provide fine furniture products, built with quality materials and hand finished details. Please carefully follow the assembly instructions to ensure your furniture is assembled correctly to provide long lasting enjoyment.

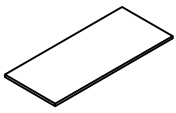
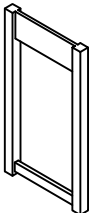
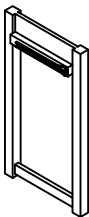
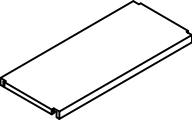
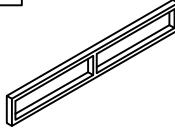
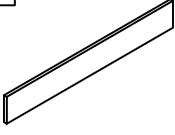



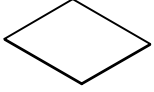

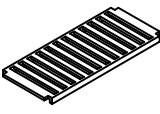









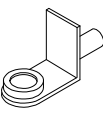

Should you experience any missing or damaged parts, **do not return to the store.** Please contact us.

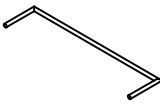
Care: Use a soft clean cloth that will not scratch the surface when dusting. Use of furniture polish is not necessary. Should you choose to use polishes, test in an inconspicuous area first. Use of solvents of any kind may damage your furniture's finish. To clean, simply use a soft clean cloth moistened with lukewarm water, then buff with a dry soft clean cloth.

Parts List

1		2		3		4		5		6	
Top panel 1 PC		Left side frame 1 PC		Right side frame 1 PC		Bottom panel 1 PC		Front frame 1 PC		Back panel 1 PC	
7		8		9		10		11		12	
Partition panel 1 PC		Drawer front panel 2 PC		Drawer left side panel 2 PCS		Drawer right side panel 2 PC		Drawer bottom panel 2 PCS		Drawer back panel 2 PCS	
13											
Adjustable shelf 1 PCS											

Hardware List

A		B		C		D		E		F		G	
Cam lock 11 PCS		Cam bolt 11 PCS		Wood Dowel 10 PCS		Drawer pull 2 PCS		Short Round head bolt 4 PCS		Allen Bolt 8 PCS		Allen wrench 1 PC	
H		I		J		K		L		M		 2 PCS  1 PC  2 PCS  2 PCS  1 PC	
Screw 16 PCS		Shelf holder 4 PCS		Long Round head bolt 2 PCS		Towel bar 1 PC		Castor With Brake 2 PCS		Castor Without Brake 2 PCS		EXTRA	

Tools Needed: Allen Wrench(Part#G)(included)
Phillips Head Screw Driver(Not included)

Step 1. Insert Cam Bolts (B) into pre-drilled holes of parts (1, 2, 3, 5 & 6) using a Phillips head screwdriver. DO NOT OVERTIGHTEN.

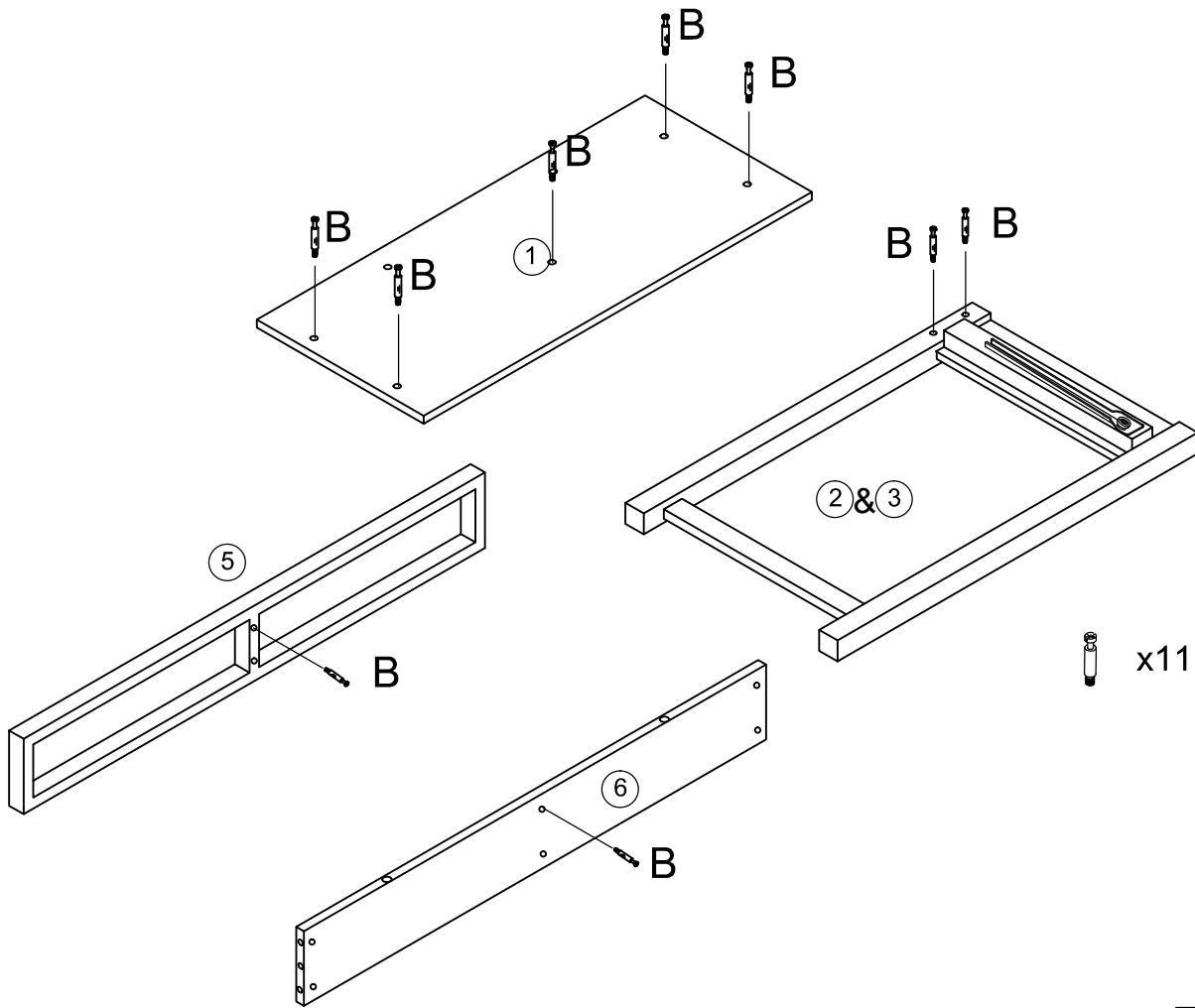

Step 2. Lay Back Panel (6) on a flat surface with Cam Bolt (Part B) facing up. Attach Right Side Frame (3) to Back Panel (6) using Cam Locks (A) & Wood Dowels as shown. Now attach Right Side Frame (3) to Bottom Panel (4) using Allen Bolts (F) as shown. Repeat the previous steps for Left Side Frame (2).

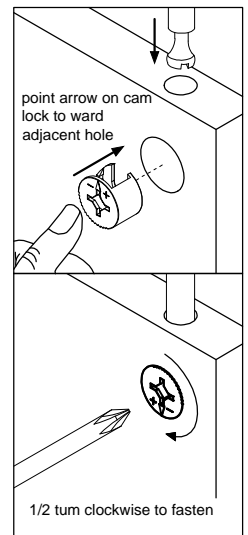
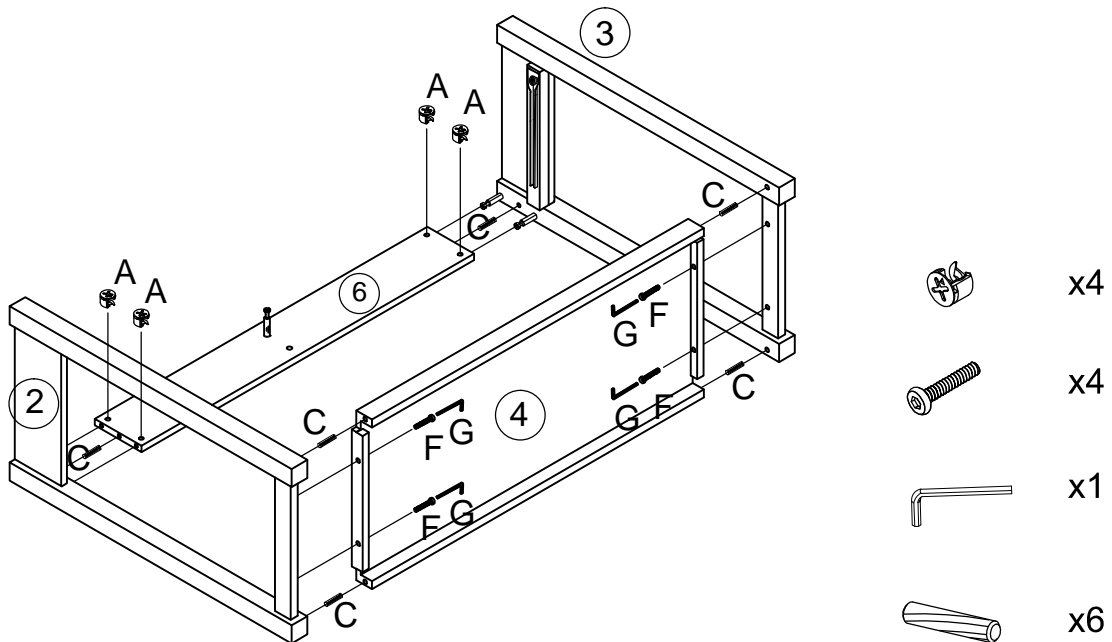

Step 3.

Attach Partition Panel (7) to Back Panel (6) using Cam Lock (A) & Wood Dowel (C) as shown. Note - Be sure the wheels on the drawer glide are facing the front of the cabinet. Now attach Front Frame (5) to Partition Panel (&) using Cam Lock (A) & Wood Dowel (C) as shown. Attach Caster with brake (L) & Caster (M) to Right & Left Side Frames (2 & 3) by rotating clockwise.

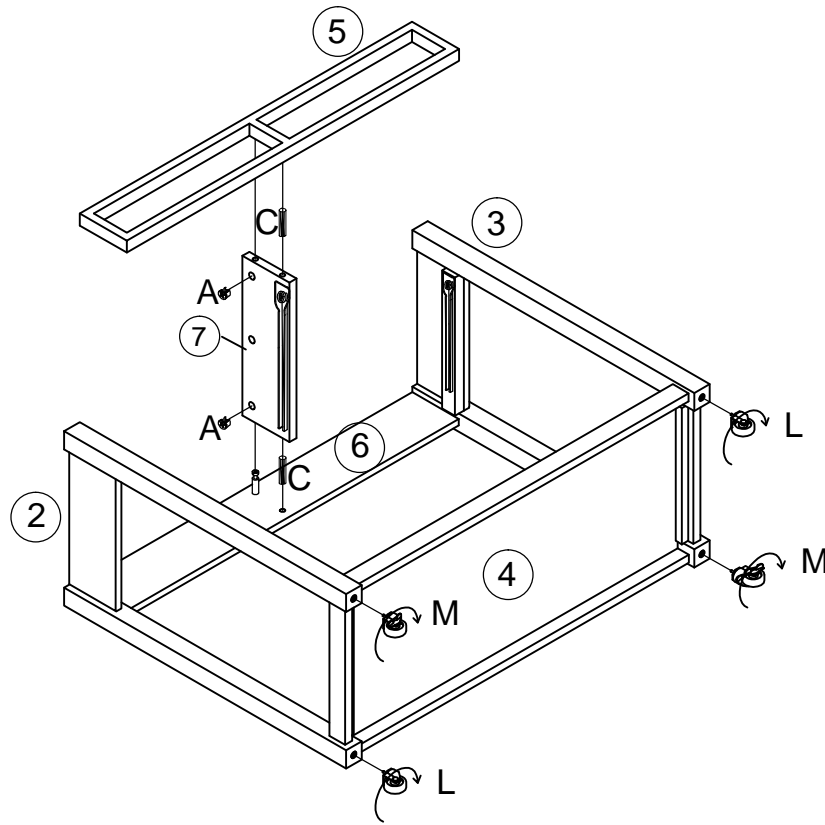
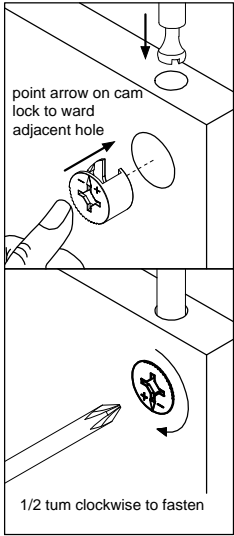

- x2
- x2
- x2
- x2

Step 4.

Attach Front Frame (5) to Right & Left Side Frames (2 & 3) using Allen Bolts (F) as shown. Attach Towel Bar (K) to Right Side Frame (3) using Long Round Head Bolts (J) as shown. Now attach Top (1) using Cam Locks (A) & Wood Dowels (C) as shown.

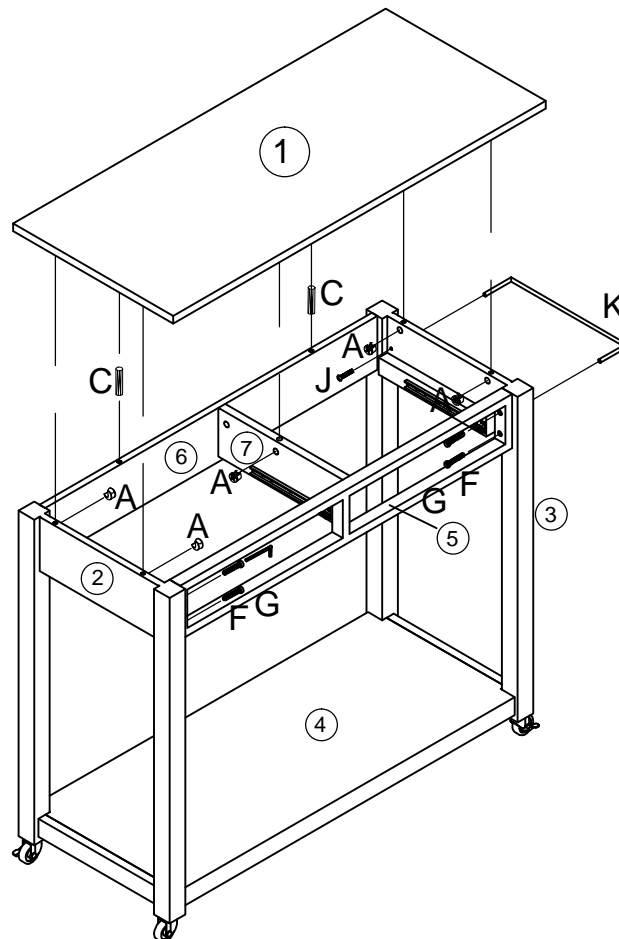
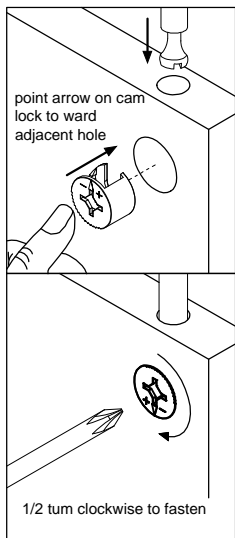

- x5
- x4
- x1
- x2
- x1
- x2

Step 5. Assemble drawers by attaching Drawer Front (8) to Left & Right Side Panels (9 & 10) using Screws (H). NOTE: BE SURE THAT THE WHEELS ON DRAWER GLIDES ARE AT THE OPPOSITE SIDE OF THE DRAWER FRONT. Insert Bottom Panel (11) into the grooves of Side Panels (9 & 10). Attach Back Panel (12) to Side Panels (9 & 10) using Screws (5) as shown. Attach Drawer Pull (D) to Drawer Front (8) using Short Round Head Bolt (E) as shown.

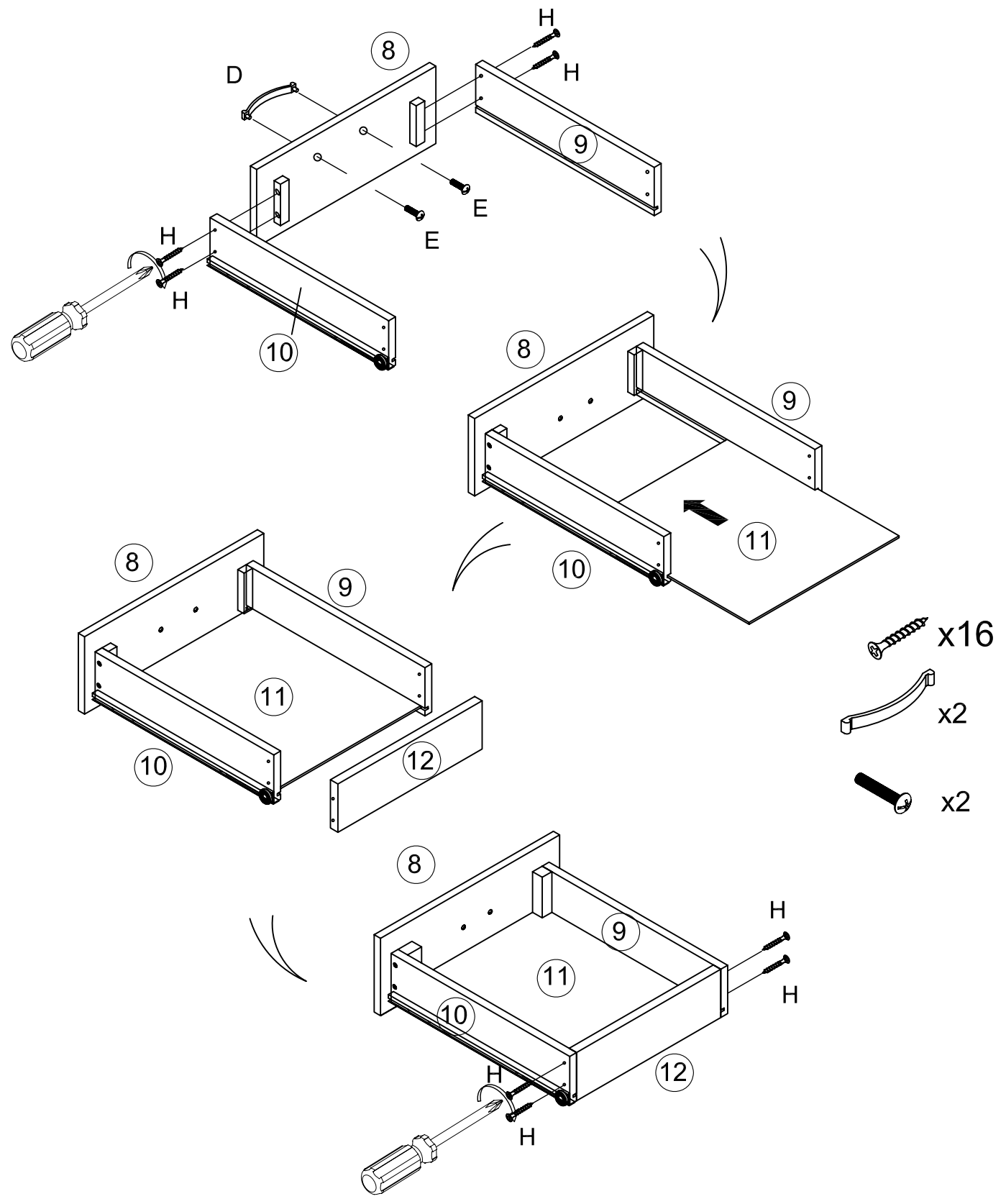

Step 6. Insert the assembled drawers into the cabinet.

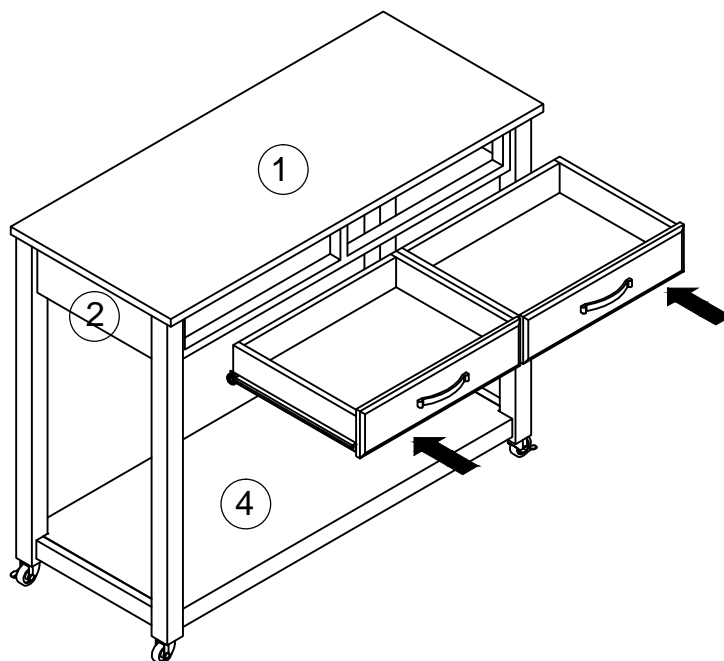

Step 7. Insert the Shelf Holders (1) into the desired location and add Adjustable Shelf (13).
Note - If you intend to use the lower portion of the island for stool storage, do not add adjustable shelf (13). Congratulations! You are finished.

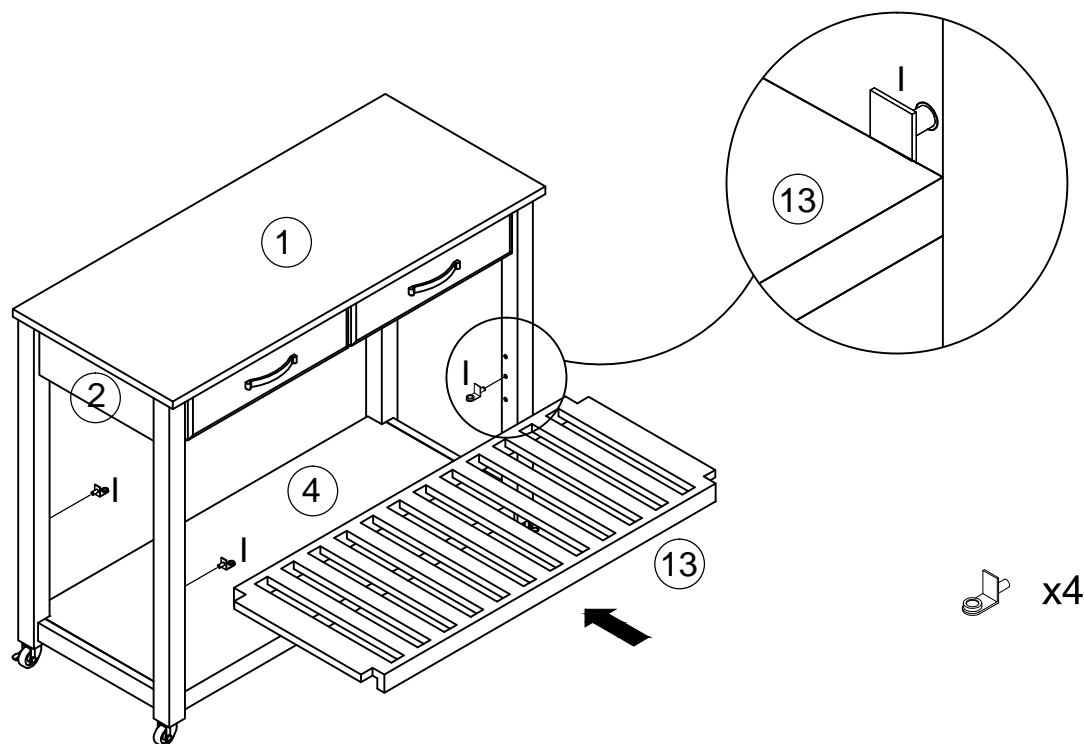

Limited Manufacturers Warranty

Our Products are warranted against defects in material and workmanship for a period of 90 days beginning from the date of sale. Should any parts be missing or defective, we will replace or repair the parts for a period of 90 days from the date of purchase.

Should you experience any missing or damaged parts, do not return to the store. Please contact us.

This warranty gives the purchaser specified legal rights in addition to any rights which may vary from state to state.

In accordance with the "Moss-Magnuson Warranty Act" of July 10, 1975, this is termed a "limited warranty" which in no way compromises our high standard of Quality and Workmanship.