

Assembly Instructions

PWS-SV6145-WT

8 CUBE STORAGE ORGANIZER

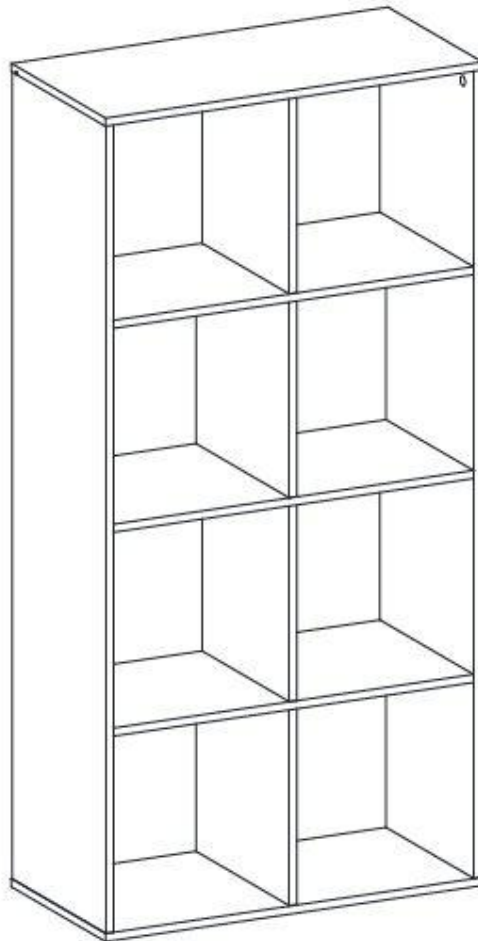

THIS INSTRUCTION BOOKLET CONTAINS **IMPORTANT** SAFETY INFORMATION. PLEASE READ AND KEEP FOR FUTURE REFERENCE.

Do Not Return This Product!

Contact our customer service team for help first.

Monday-Friday 9am - 5pm CST

Visit: support@cenports.com



WARNING

- Unit can tip over causing severe injury or death.
- Anchor unit to stud in wall (if instructed to).
- Do Not allow children to climb on unit.
- Put heavy items on lower shelves or drawers.



Assembly Difficulty Meter

ASSEMBLY OVERVIEW

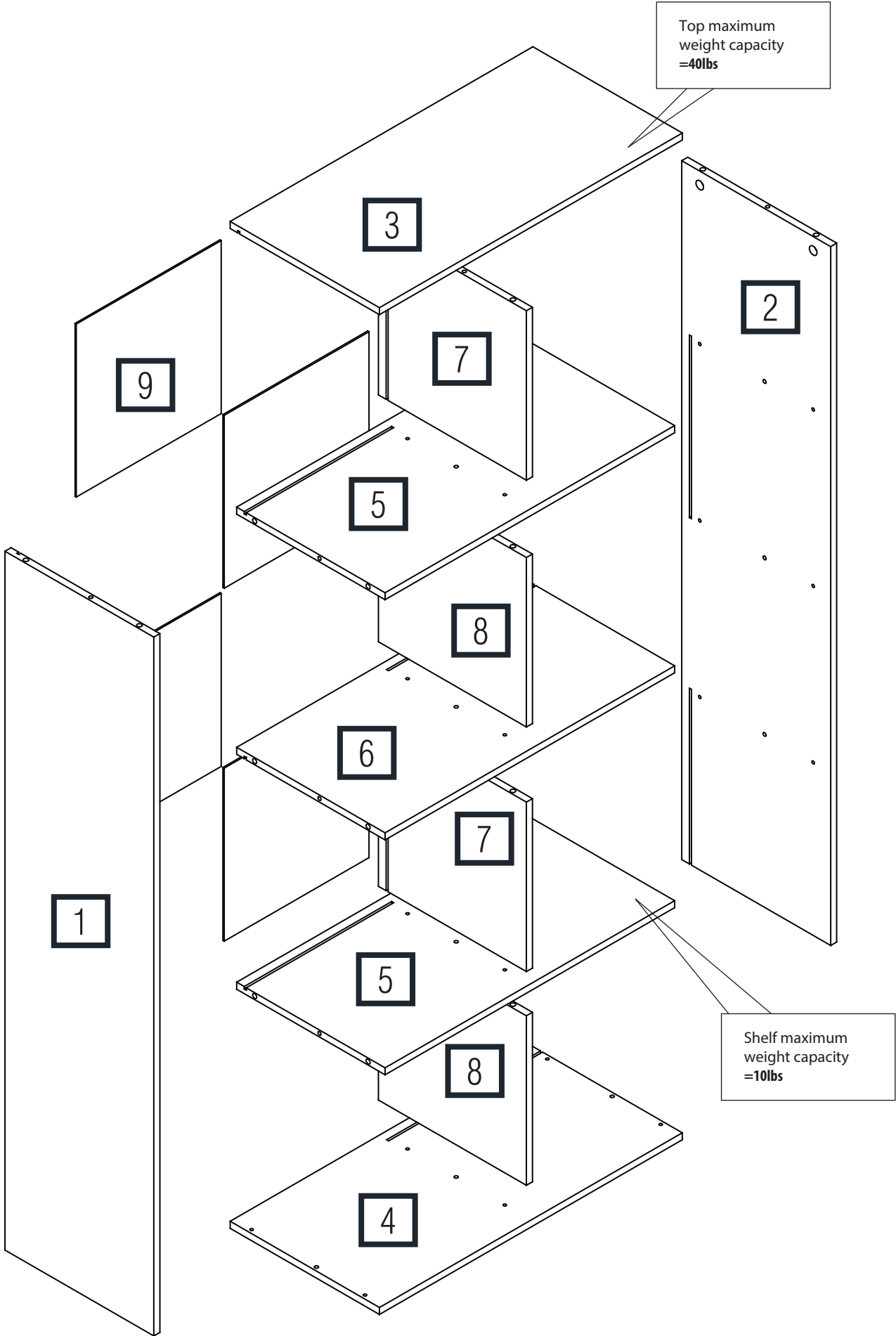





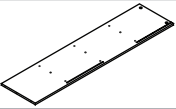
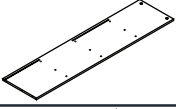
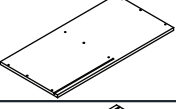
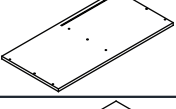
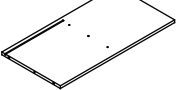

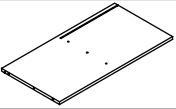
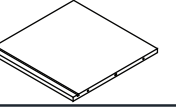
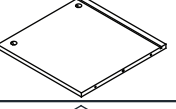
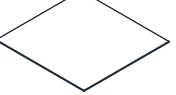
PARTS AND HARDWARE LIST

*Please look for part number on the side of the part. It either is stamped or has a labeled sticker.

PART	DESCRIPTION	STOCK NO	QTY
1	Side Panel Left 	51-81201A	1
2	Side Panel Right 	51-81201B	1
3	Top Panel 	51-81201C	1
4	Bottom Panel 	51-81201D	1
5	Shelf Panel A 	51-81201E	2

PART	DESCRIPTION	STOCK NO	QTY
6	Shelf Panel B 	51-81201F	1
7	Center Panel A 	51-81201G	2
8	Center Panel B 	51-81201H	2
9	Back Panel 	51-81201J	4

HARDWARE KIT STOCK # 51-81201KIT

PART	DESCRIPTION	QTY
A	Minifix Bolt 	24
B	Cam 	24
C	Wood Dowel (6 x 30mm) 	18
D	CSK Screw (M4.7 x 38mm) 	12
E	Cam Caps 	24
F	Allen Key (M4) 	1

CAUTION

- READ THE INSTRUCTION MANUAL BEFORE ASSEMBLING.
- REMOVE ALL PIECES BEFORE BEGINNING INSTALLATION.
- OPEN THE HARDWARE AS NEEDED.
- ASSEMBLE IN AN AREA WITH PLENTY OF SPACE.
- READ EACH STEP BEFORE BEGINNING CONSTRUCTION.
- HAVE THE TOOLS BELOW BEFORE YOU BEGIN ASSEMBLING.
- NEVER FORCE THE SCREWS OR FITTINGS.
- KEEP THIS MANUAL FOR FUTURE REFERENCE.
- TIGHTEN ALL THE SCREWS EVERY 6 MONTHS.
- DO NOT SHIFT OR DRAG THE PRODUCT AFTER ASSEMBLY.
- THE FOLLOWING TOOLS ARE NOT INCLUDED.

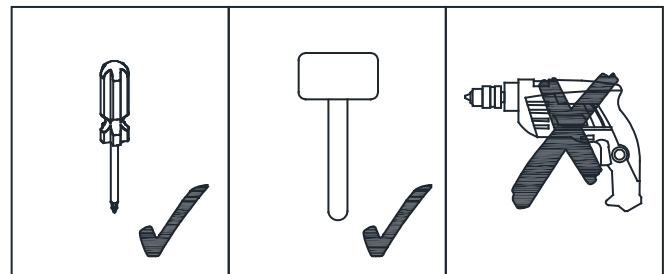

CLEANING AND CARE

- CLEAN SURFACES WITH A DRY OR DAMP CLOTH.
- DO NOT USE ABRASIVE CLEANERS.
- DO NOT USE FURNITURE WAX OR POLISH AS THE UNIT IS FINISHED WITH A PROTECTIVE CLEAR LACQUER.

REPLACEMENT PARTS

IF YOU ARE MISSING ANY OF THE PARTS ABOVE, OR IF YOU HAVE A DAMAGED PART, PLEASE VISIT WWW.COMFORTPRODUCTS.NET/SUPPORT REFERENCE THE MODEL # ON THE FRONT OF THIS MANUAL. SIMPLY COMPLETE THE INFORMATION, INCLUDING THE PART YOU NEED. THE PART WILL NORMALLY BE SHIPPED WITHIN 48 HOURS.

ASSEMBLY INSTRUCTION

Step 1:

Start assembling by fixing the Wood Dowels (C) to Side Panel Left (1), Side Panel Right (2), two Shelf Panels A (5), Shelf Panel B (6), two Center Panels A (7) and two Center Panels B (8).

Part # C  x 18

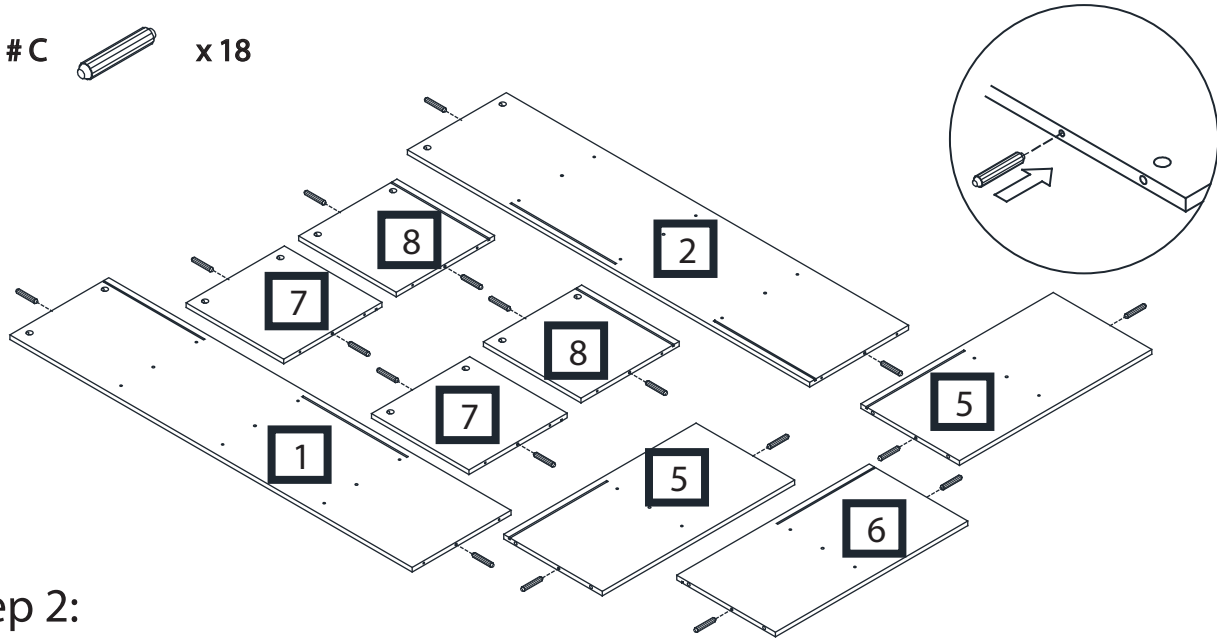

Step 2:

Using a phillips head screwdriver, fix the Minifix Bolts (A) to Side Panel Left (1), Side Panel Right (2), Top Panel (3), two Shelf Panels A (5), and Shelf Panel B (6).

Part # A  x 24

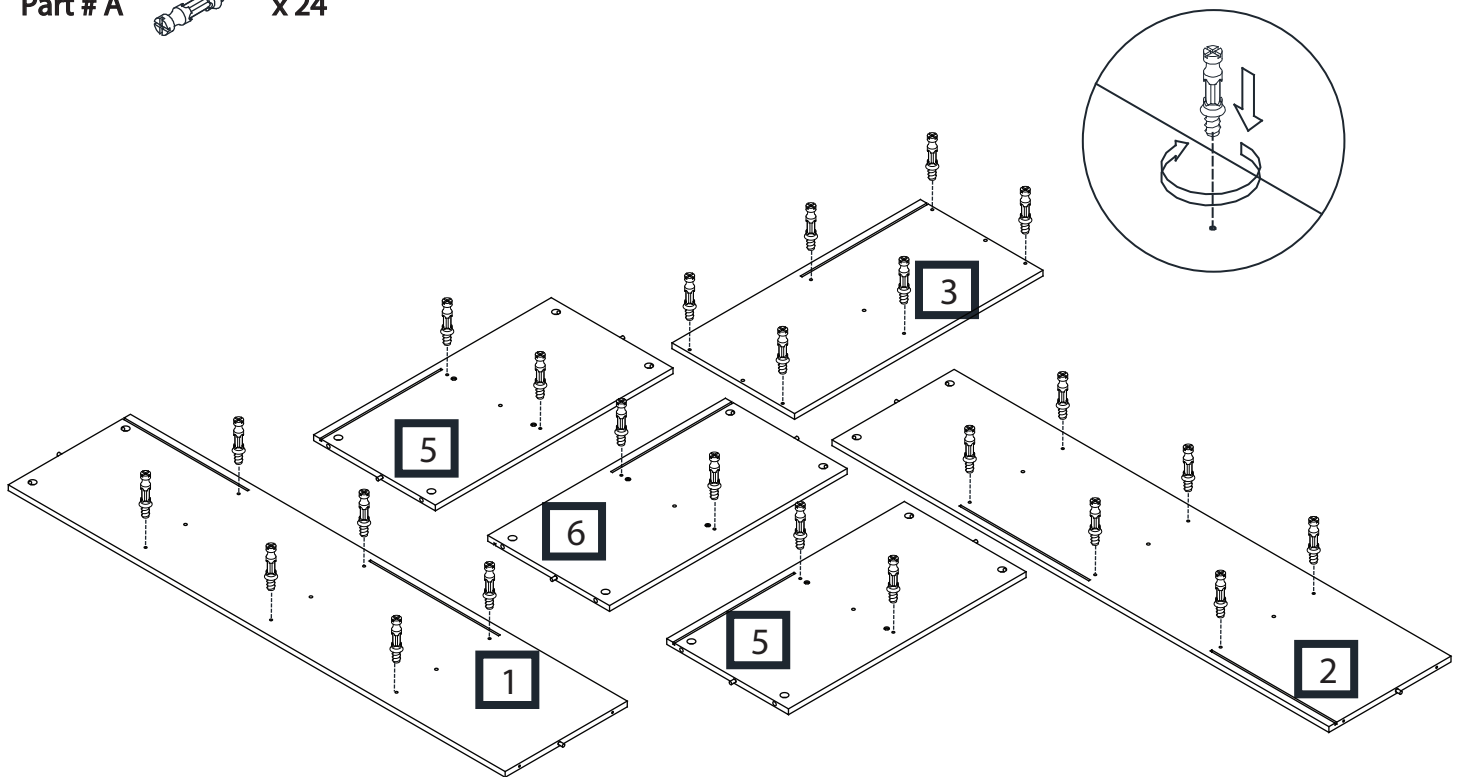

ASSEMBLY INSTRUCTION

Step 3:

Use two CSK Screws (D) to attach Shelf Panel A (5) and Center Panel A (7). Make sure that the grooves for the Back Panel are aligned. (These grooves are on the sides not shown in the drawing below).

Part # D  x 2pcs

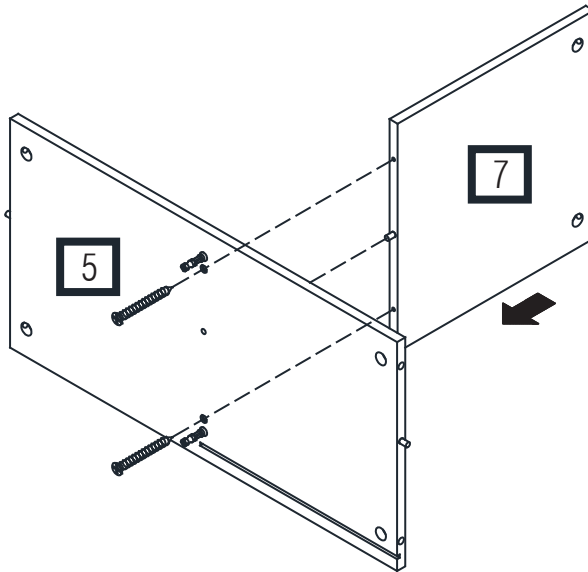

Step 4:

Insert the Minifix Cams (B) into the Center Panel (8). Attach the Center Panel (8) to Shelf Panel A (5). While doing this make sure that the grooves for the Back Panel are aligned. Tighten the two Minifix Cams (B) clockwise and then cover them with Cam Caps (E).

Part # B  x 2pcs

Part # E  x 2pcs

Caution :
Do not over tighten

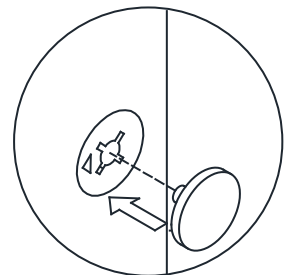
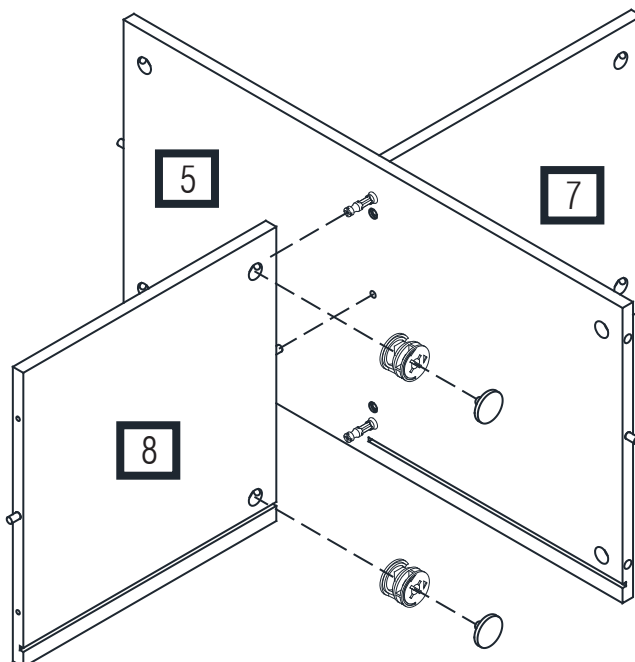
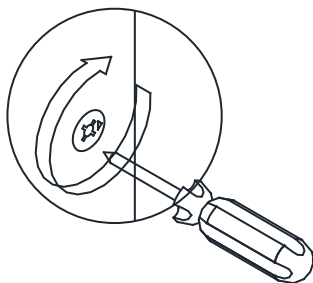

ASSEMBLY INSTRUCTION

Step 5:

Use two CSK Screws (D) to attach the Shelf Panel B (6) and Center Panel B (8). Make sure that the grooves for the Back Panel are aligned.

Part # D  x 2pcs

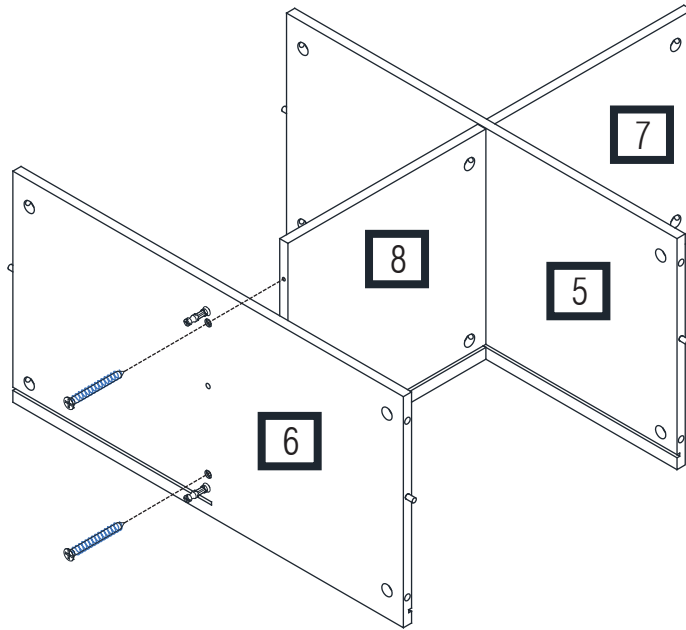

Step 6:

Insert the Minifix Cams (B) into Center Panel A (7). Attach Center Panel A (7) to Shelf Panel B (6). While doing this make sure that the grooves for the Back Panel are aligned. Tighten the two Minifix Cams (B) clockwise and then cover them with Cam Caps (E).

Part # B  x 2pcs

Part # E  x 2pcs

Caution :
Do not over tighten

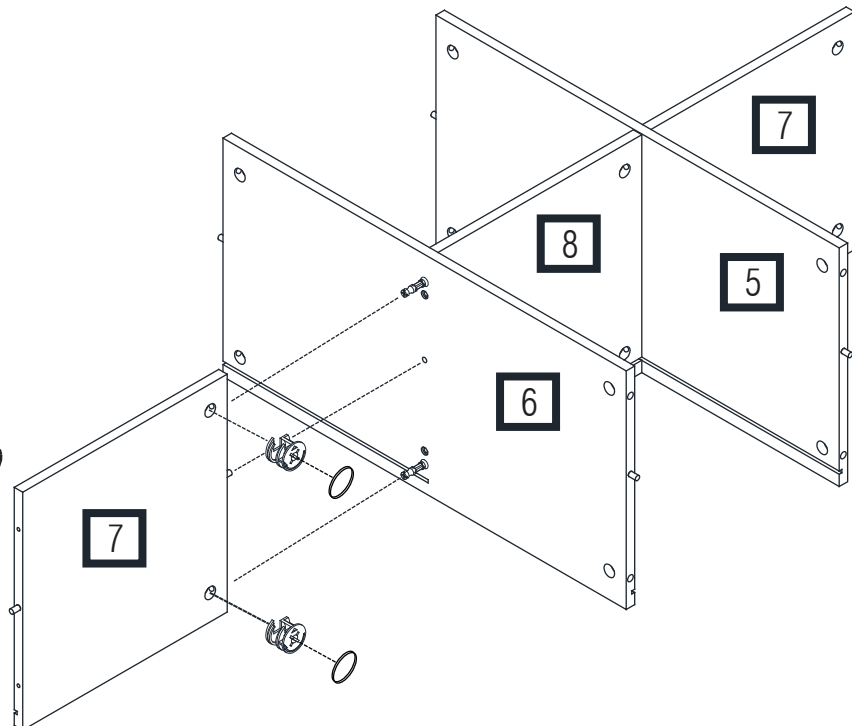
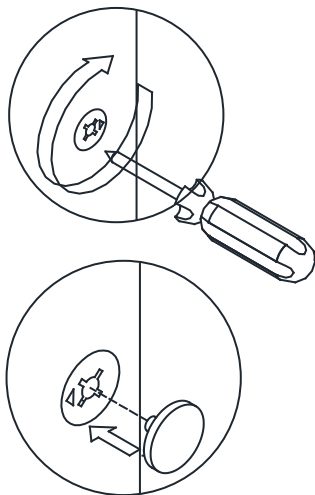

ASSEMBLY INSTRUCTION

Step 7:

Use two CSK Screws (D) to attach Shelf Panel A (5) to Center Panel A (7). Make sure that the grooves for the Back Panel are aligned.

Part # D  x 2pcs

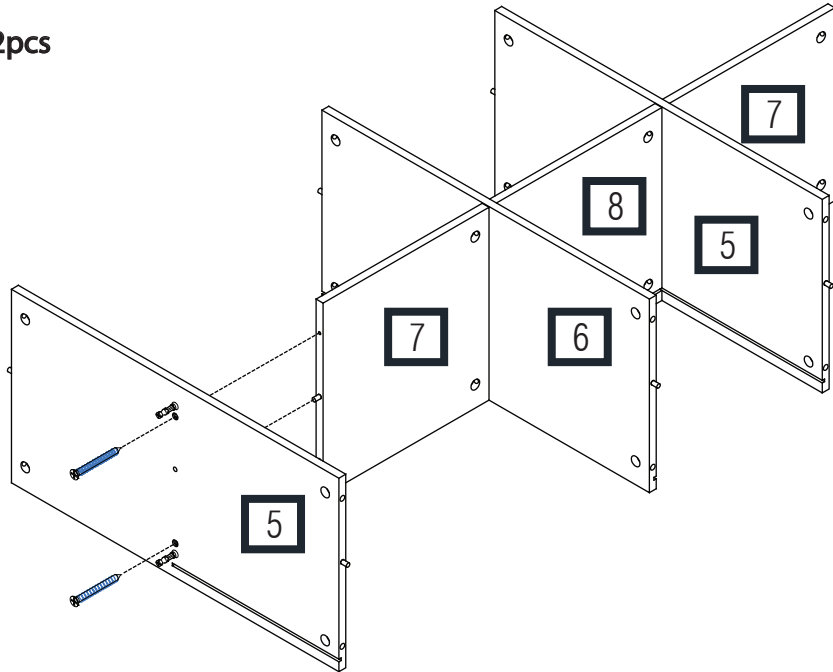

Step 8:

Insert the Minifix Cams (B) into Center Panel B (8). Attach Center Panel B (8) to Shelf Panel A (5). While doing this make sure that the grooves for the Back Panel are aligned. Tighten the two Minifix Cams (B) clockwise and then cover them with Cam Caps (E).

Part # B  x 2pcs

Part # E  x 2pcs

Caution :
Do not over tighten

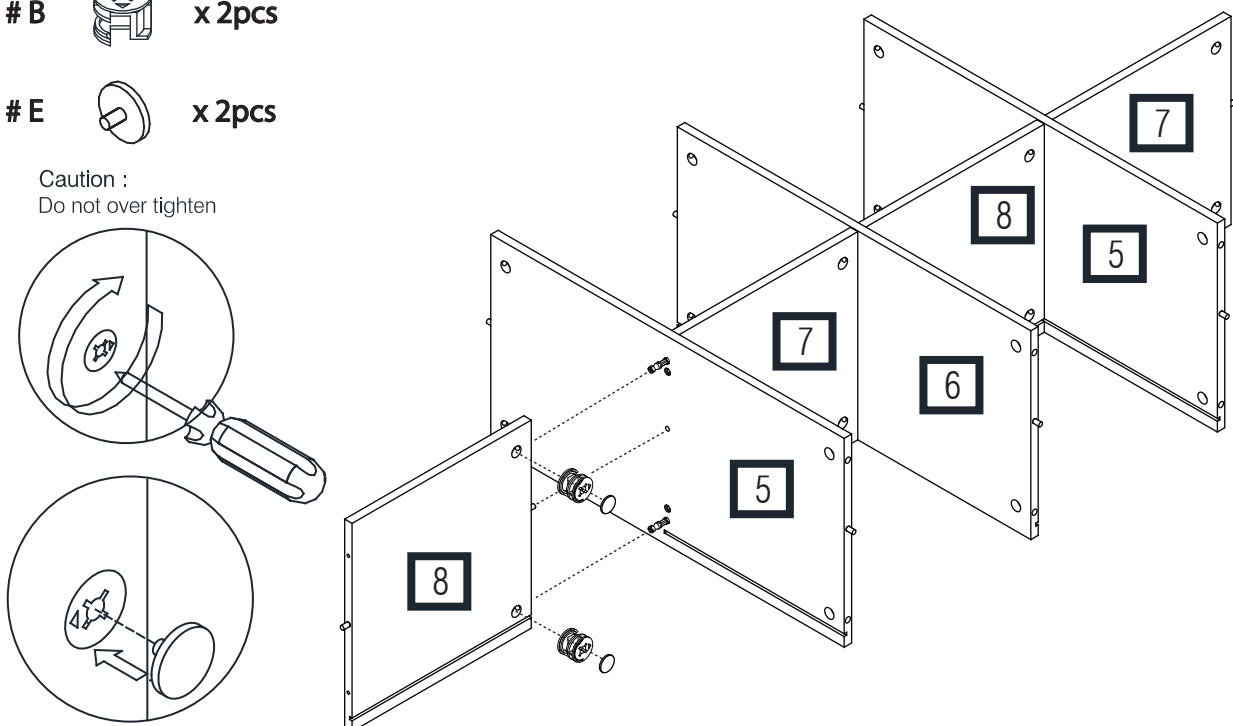

ASSEMBLY INSTRUCTION

Step 9:

Slide in one Back Panel (9) with the finished side facing inside the cube.

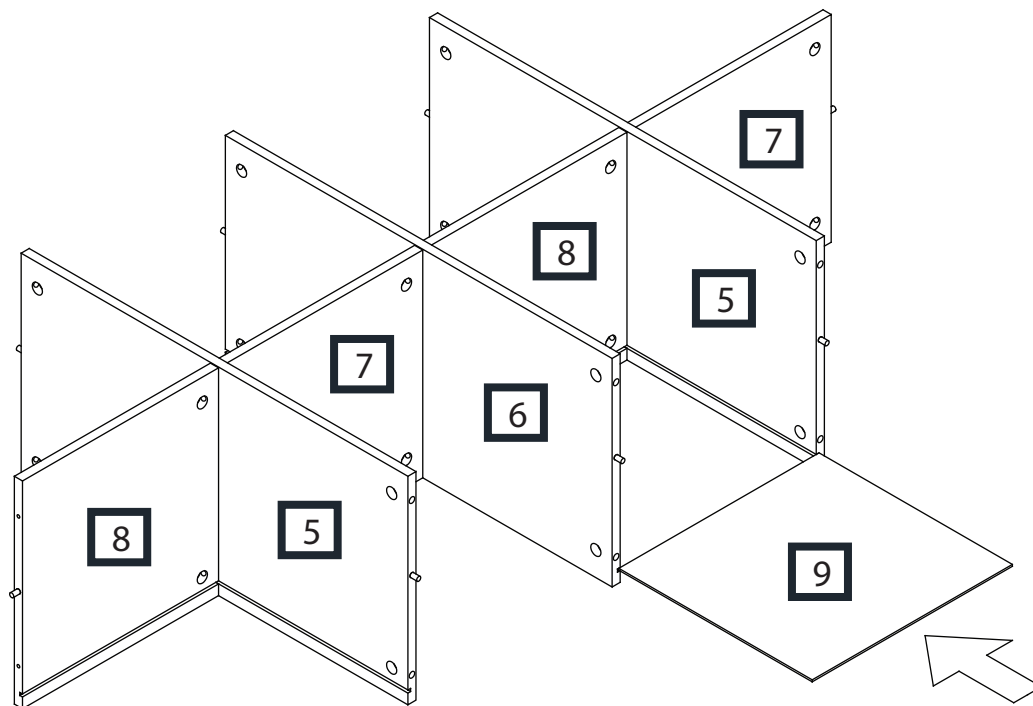

Step 10:

Insert the Minifix Cams (B) into Shelf Panel A (5) and Shelf Panel B (6). Attach Side Panel Right (2) to both Shelf Panels A (5) and Shelf Panel B (6). While doing this make sure that the groove in Side Panel Right (2) is aligned with the panel which you have just inserted. Tighten the six Minifix Cams (B) clockwise and then cover them with Cam Caps (E).

Part # B  x 6pcs

Part # E  x 6pcs

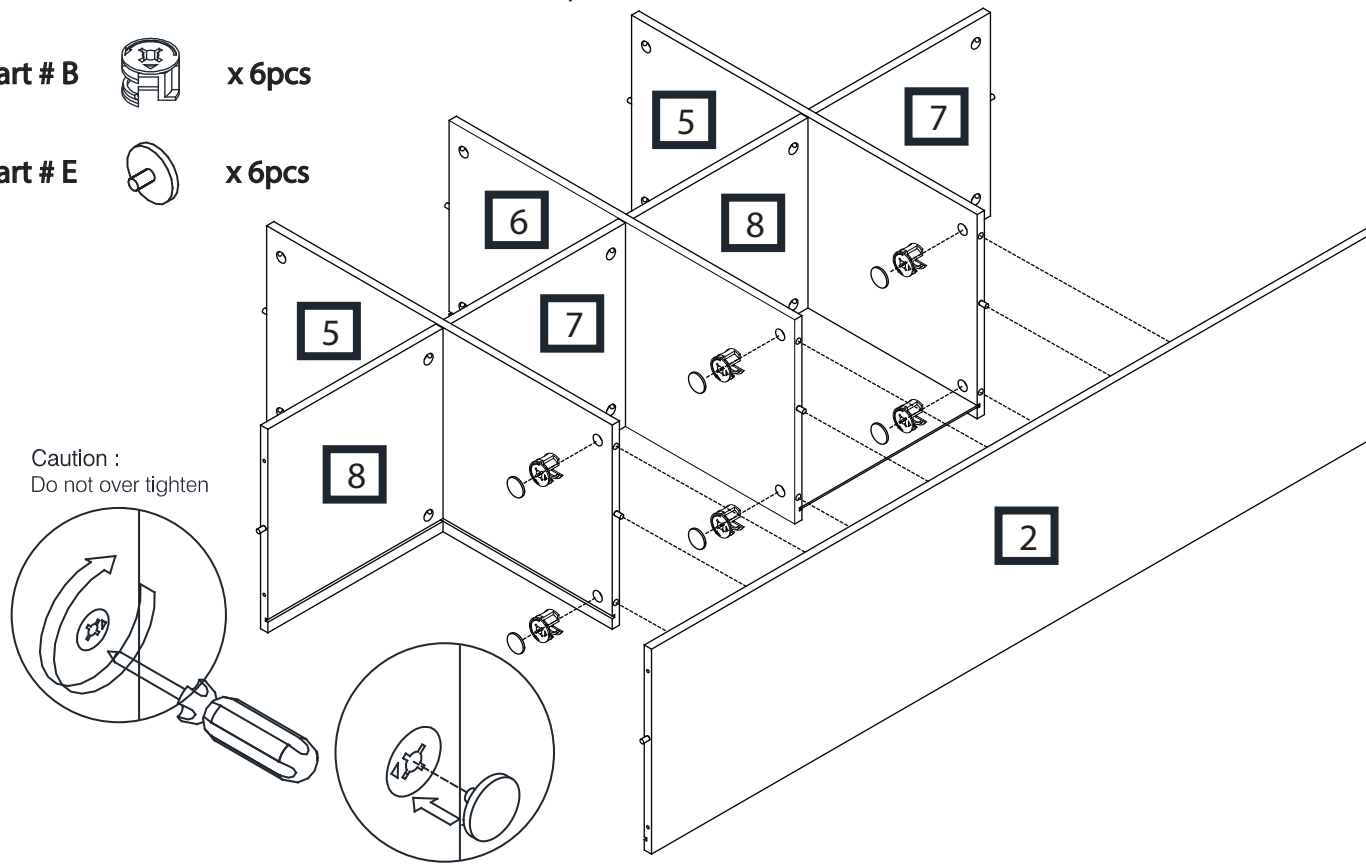

ASSEMBLY INSTRUCTION

Step 11:

Slide in one Back Panel (9) with the finished side facing inside the cube.

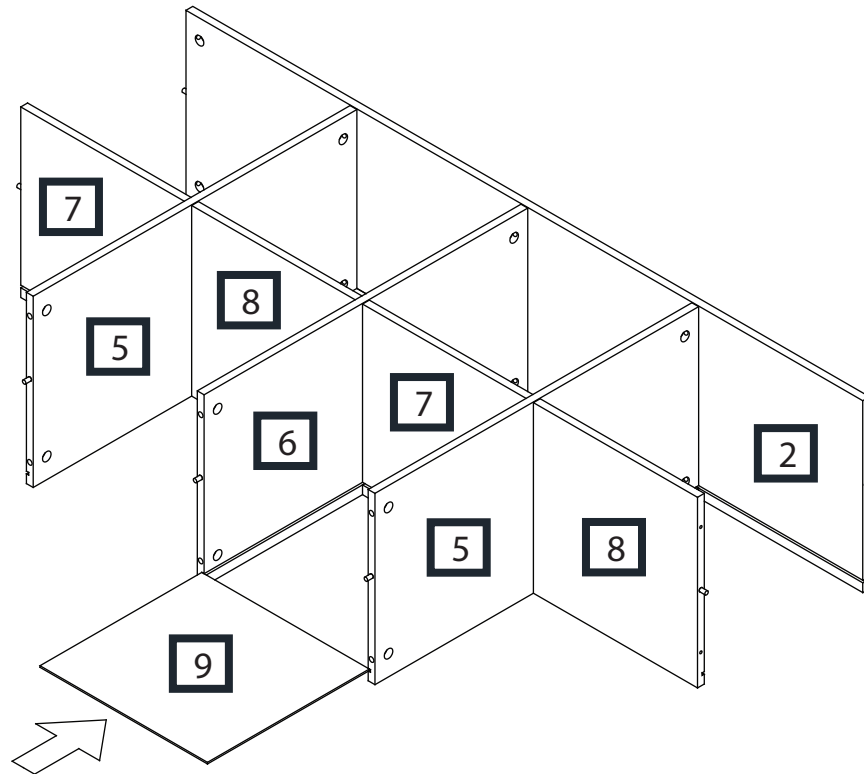

Step 12:

Insert the Minifix Cams (B) into Shelf Panel A (5) and Shelf Panel B (6). Attach Side Panel Left (1) to both Shelf Panels A (5) and Shelf Panel B (6). While doing this make sure that the groove in Side Panel Left (1) is aligned with the panel which you have just inserted. Tighten the six Minifix Cams (B) clockwise and then cover them with Cam Caps (E).

Part # B  x 6pcs

Part # E  x 6pcs

Caution :
Do not over tighten

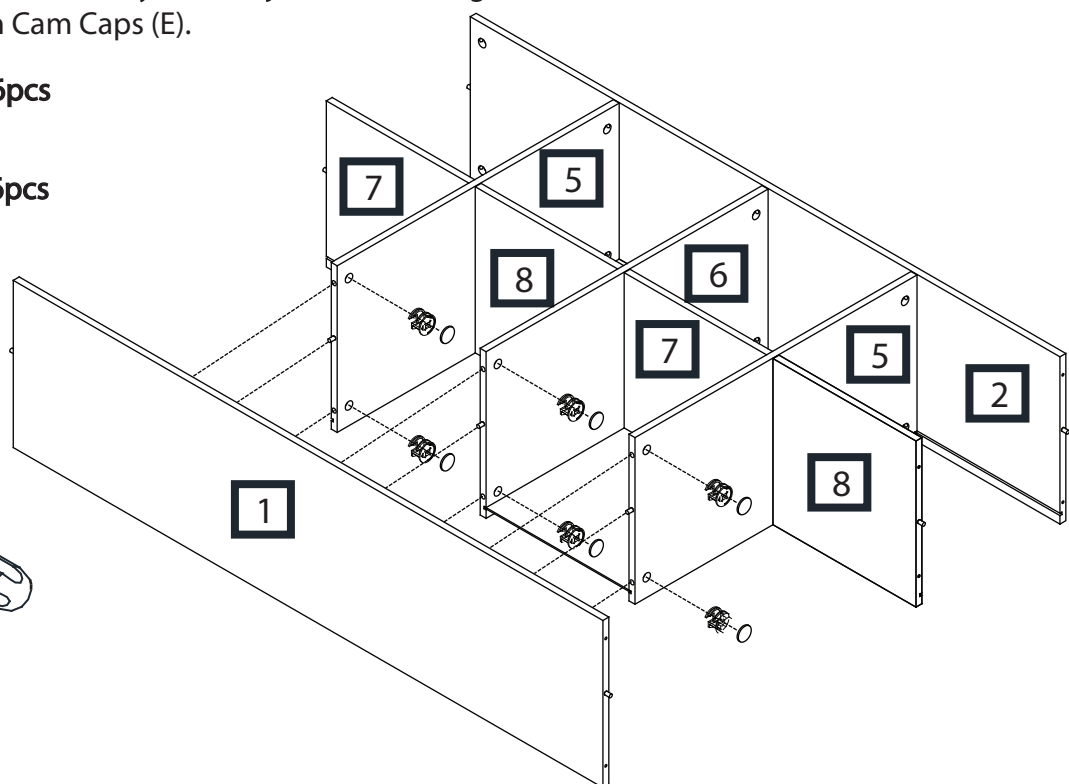
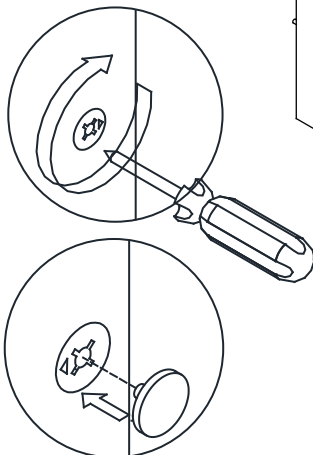

ASSEMBLY INSTRUCTION

Step 13:

Slide in one Back Panel (9) with the finished side facing inside the cube.

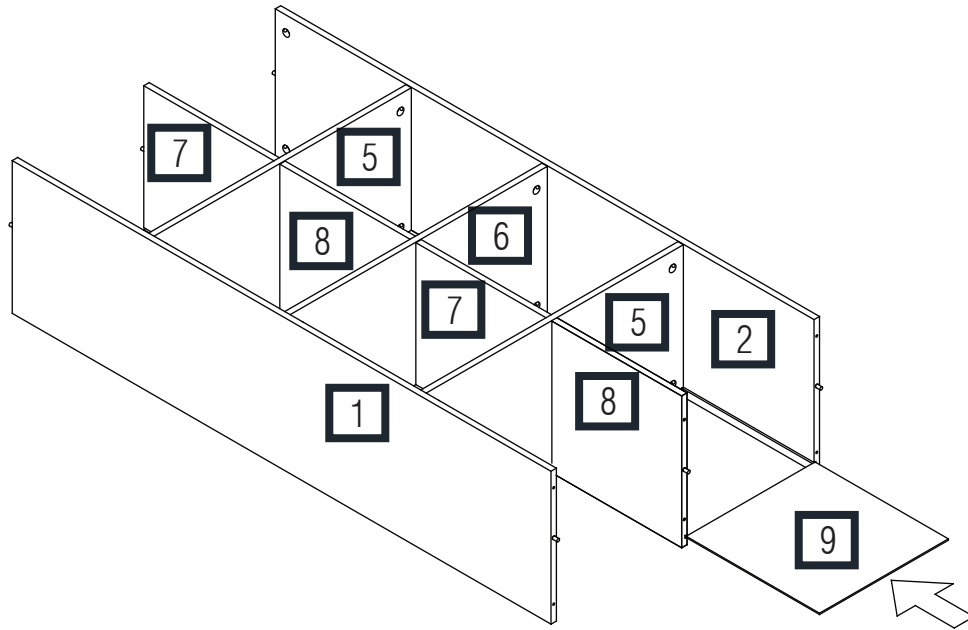

Step 14:

Use six CSK Screws (D) to attach the Bottom Panel (4) to Side Panel Left (1), Side Panel Right (2) and Center Panel B (8). Make sure that the groove in the Bottom Panel (4) is aligned with the panel which you have just inserted.

Part # D  x 6pcs

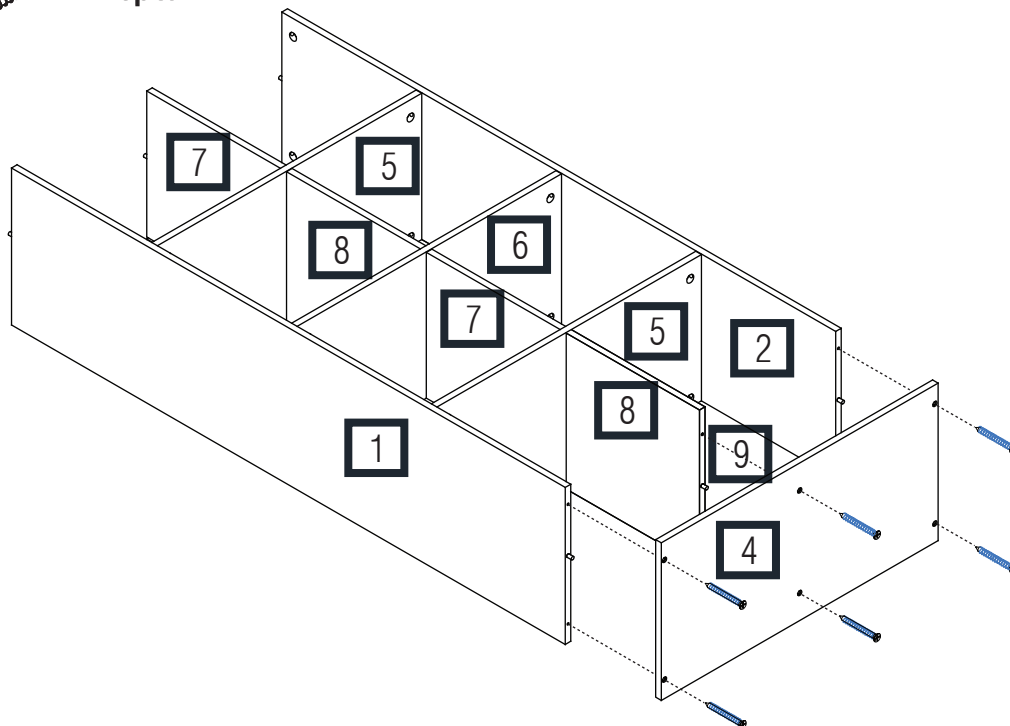

ASSEMBLY INSTRUCTION

Step 15:

Slide in the last Back Panel (9) with the finished side facing inside the cube.

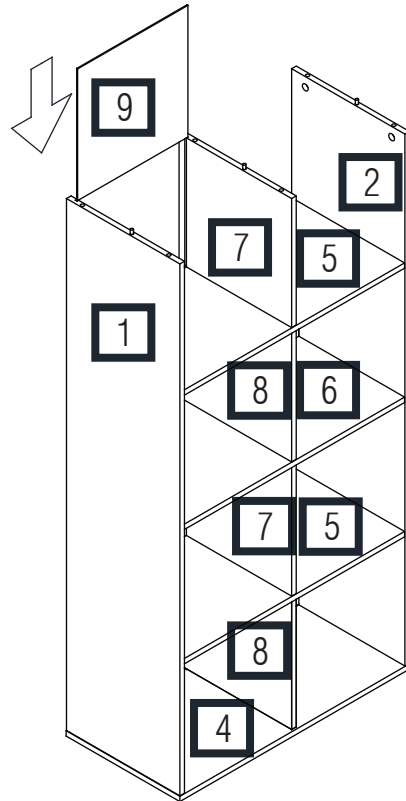

Step 16:

Insert the Minifix Cams (B) into Side Panel Left (1) Side Panel Right (2) and Center Panel A (7). Attach the Top Panel (3) to the Side Panel Left (1), Side Panel Right (2) and Center Panel A (7). Make sure that the groove is aligned with the panel which you have just inserted. Tighten the six Minifix Cams (B) clockwise and then cover them with Cam Caps (E).

Part # B  x 6pcs

Part # E  x 6pcs

Caution :
Do not over tighten

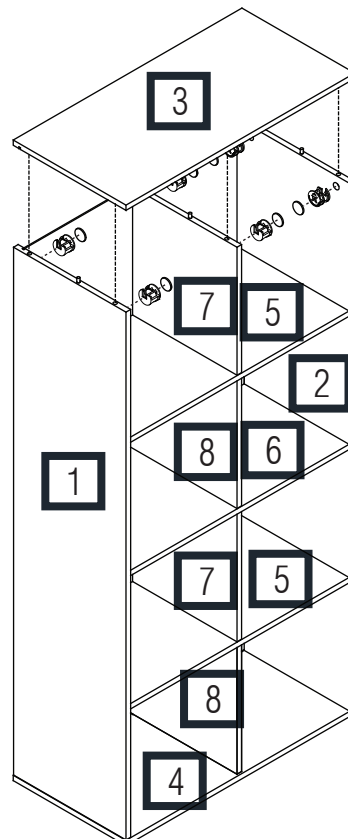
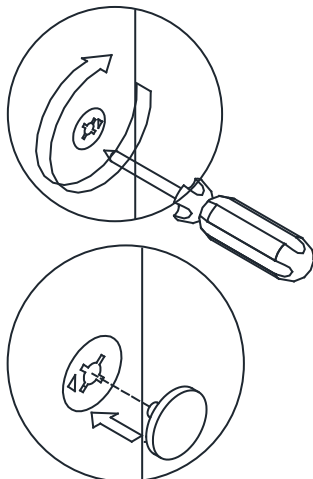

Tips for Proper Care and Maintenance of Particle Board Furniture

Understanding Particle Board

Particle Board Composition:

Particle board is composed of wood particles, such as sawdust and wood chips, bonded together with adhesive under high pressure. The surface of particle board is typically covered with a laminate or veneer to enhance its appearance.

Sensitivity to Moisture:

One of the primary vulnerabilities of particle board is its sensitivity to moisture. Excessive exposure to water or high humidity can cause swelling, warping, or delamination.

Cleaning and Maintenance Guidelines

1. Dust Regularly:

Regular dusting is crucial to prevent the accumulation of dirt and grime on particle board surfaces. Use a soft, dry cloth or a duster to gently remove dust.

2. Avoid Excess Water:

Particle board should not be cleaned with excessive water or harsh cleaning agents. Use a slightly damp (not wet) cloth with a mild cleaner specifically designed for wood surfaces.

3. Protect from Direct Sunlight:

Prolonged exposure to direct sunlight can cause discoloration or fading of the particle board surface. Position furniture away from direct sunlight or use window coverings to reduce exposure.

4. Use Coasters and Mats:

Protect particle board surfaces from hot items, spills, and scratches by using coasters, placemats, or felt pads under objects. This precaution prevents damage and preserves the furniture's appearance.

5. Repair Minor Damage Promptly:

Address minor damage such as scratches or small chips promptly. You can use touch-up markers or putty to fill in and conceal minor imperfections. Ensure that the repair materials match the furniture's colour and finish.