

GW-F-RAD-34"-40"

Shower Enclosure Installation Guide

Solaris Radius Single Fixed Panel
Shower Enclosure



**Read all Instructions Prior to Installation.
Professional Installation Required.**



Watch Installation Video Prior to Installation.

GLASSWAREHOUSE

Contents

Important Safety Information4
What is Included in Your Install Kit6
Installation Tools.7
Pre-Installation Steps8
Installation Steps	12
Hardware Care & Maintenance.	22
Glass Care & Maintenance	23
Warranty	26





WARNING!

Important Safety Information

Read Before Installing

- To reduce risk of injury, this product must be installed by a professional or by an individual experienced in glass installation and familiar with the structural and safety requirements of this type of project.
- Do **NOT** attempt to lift or carry a large glass panel alone. To prevent injury or damage, always use assistance and/or professional-grade suction cups to safely position and secure the glass.
- Always handle tempered glass with extreme care. To reduce risk of breakage, do **NOT** lean, rest, or apply force to installed or uninstalled glass panels.
- Glass Warehouse reserves the right to modify, improve, or redesign any product at any time, without prior notice, to enhance performance or user safety.
- The safety of the installation is the sole responsibility of the installer.
- Some installations require drilling into the threshold or tile. Always consult the manufacturer of your base or tile material before drilling.
- Illustrations and diagrams in this guide are for reference only and are not to scale.

Tempered Glass Safety Warning

Tempered glass can shatter without warning if mishandled, installed incorrectly, or subjected to stress.

Do NOT install or use any glass panel that:

- Has chipped corners, slivered edges, or visible damage.
- Has been dropped or impacted against any hard surface (tile, marble, glass, etc.).

Primary causes of tempered glass breakage include:

- Improper handling, storage, or installation.
- Missing or misaligned hardware, gaskets, or brackets.
- Excessive pressure or impact on glass edges or corners.
- Loose rollers or moving parts, misaligned brackets or hardware, or overtightened fittings.
- Aggressive operation or misuse (slamming, leaning, or hanging on panels).

Even small imperfections or misalignment can cause delayed spontaneous breakage, hours or days later, due to stress concentration on the glass edges.

If damage is suspected, discontinue use immediately and contact Glass Warehouse customer service.

Installation & Preparation

- Carefully inspect all packaging before beginning installation. Verify all parts are present using the product diagram and report any missing or damaged components within 30 days of delivery.
- Glass Warehouse will not replace damaged or missing components after this period or once installation has begun.
- Check that walls are plumb, level, and square before installing. Improper wall angles or uneven thresholds can cause stress on the glass and result in product failure.
- Always install against finished (tiled) walls and thresholds only.
- If installing into a fiberglass enclosure always mount panel-supporting hardware to studs.
- Protect all glass surfaces during installation – never place glass directly on tile or concrete. Keep corner protectors in place until panels are ready to be installed.
- Always wear appropriate personal protective equipment (PPE) – safety glasses, gloves, and non-slip footwear.

Safety & Maintenance

WARNING: To reduce risk of injury or death:

- Read and follow all installation instructions.
- Do **NOT** use non-Glass Warehouse provided component parts for installation.
- Do **NOT** allow children to play with, hang from, or slam the sliding door.
- Do **NOT** lean or push against the glass panels at any time.
- Inspect all glass and hardware regularly for signs of loosening, corrosion, or misalignment. Tighten or replace as necessary.

NOTICE: To reduce risk of damage associated with water leaks:

- Use mild, non-abrasive cleaners only. Avoid acids, bleach, or harsh chemicals.
- Replace any damaged or missing seals immediately to prevent leaks and maintain structural integrity (see contact information below).
- Always allow 36 hours minimum for silicone to cure before using the shower.

Important Safety Information







(Continued)

Risk of Injury or Death

Glass Warehouse assumes no responsibility for injury or property damage resulting from:

- Improper installation or modification of components
- Failure to follow the instructions provided
- Use of damaged or misaligned glass panels
- Neglect or improper maintenance

Install Guide Legend

	Indicates a hazardous situation that, if not avoided, will result in death or serious injury.
	Indicates a hazardous situation that, if not avoided, could result in death or serious injury.
	Indicates a hazardous situation that, if not avoided, could result in minor or moderate injury.
	Indicates practices not related to personal injury.
	Indicates recommended practice / correct method.
	Indicates not recommended practice / incorrect method.

**All drawings in this installation manual are for illustrative purposes only and are not drawn to scale.*



Have Questions? Need Some Help?

Contact Us!

Email: inquiries@GlassWarehouse.us

Phone: (760) 536-3640

Hours of Operation:

Monday - Thursday: 8:00AM - 5:00PM PST

Friday: 8:00AM - 4:00PM PST

Saturday: 8:00AM - 12:30PM PST

About Our Glass

Highest Standard Glass Panels

Our glass panels exceed most manufacturers standard height and thickness, providing extra protection against overspray and splashing and ensuring long-term durability.



Tempered Safety Glass

Manufactured to SGCC standards with ANSI Z97.1, 16 CFR 1201 & CGSB 12.1 certification. This tempering process makes our shower doors extremely resilient and extra strong.

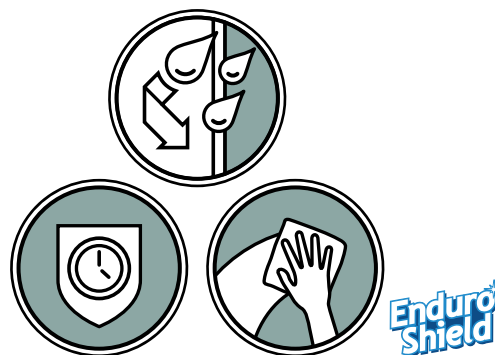

Protective Glass Coating

Glass treated with ENDURO SHIELD®, the revolutionary non-stick treatment that repels soap scum, grime, dirt, and reduces cleaning time by up to 90%.

What is Included in Your Install Kit

Your Order Will Ship in 2 Boxes

Box 1 of 2

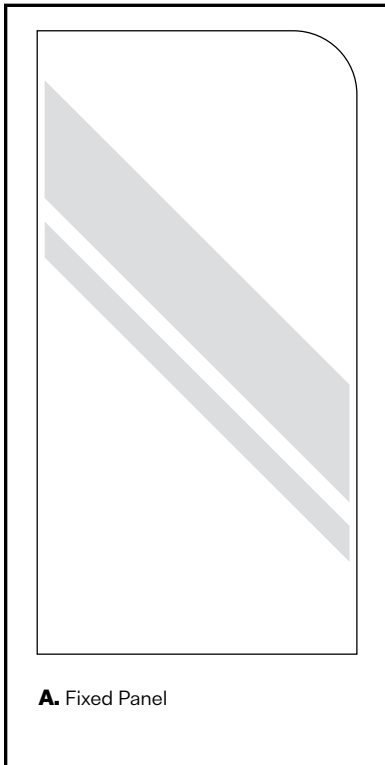

Box 2 of 2

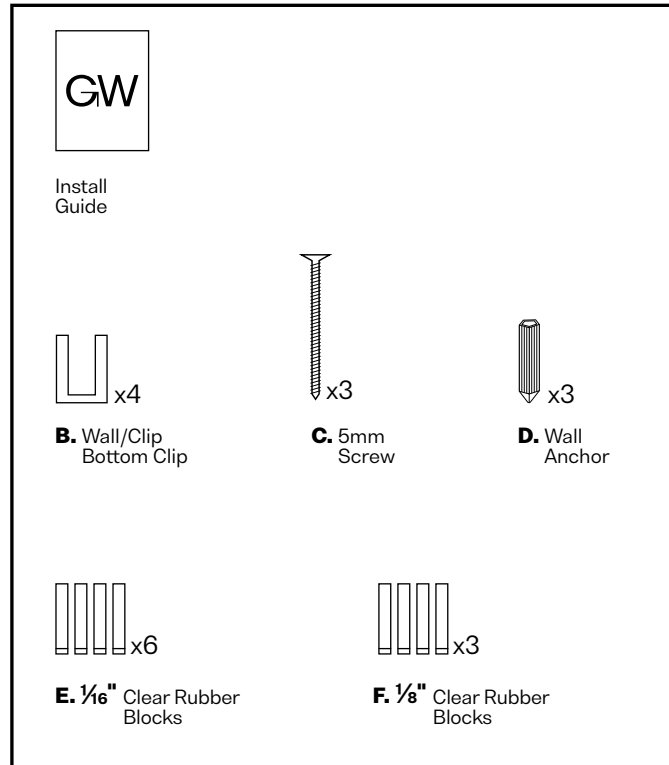

Installation Tools



T1. Cardboard Packaging

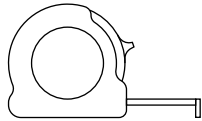

T2. Measuring Tape



T3. Pencil



T4. Long Level



T5. Level



T6. Phillips Head Screwdriver



T7. Flat Head Screwdriver



T8. Drill



T9. 1/8" Drill Bit



T10. 1/4" Drill Bit



T11. 1/8" Tile Drill Bit



T12. 1/4" Tile Drill Bit

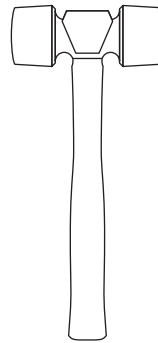

T13. Rubber Mallet



T14. Utility Knife

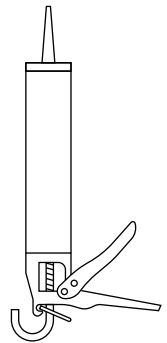

T15. Silicone



T16. Spray Bottle

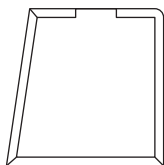

T17. Spatula

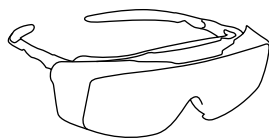

Safety Goggles

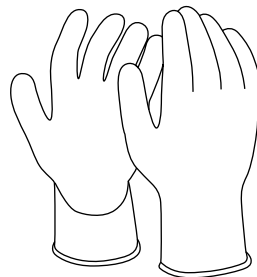

Cut Resistant Gloves

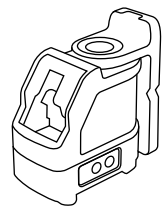

Laser Level (optional)

Pre-Installation Steps

WARNING

Check Before You Install: Failure to complete all checks may result in improper installation, poor product function, and/or structural instability.

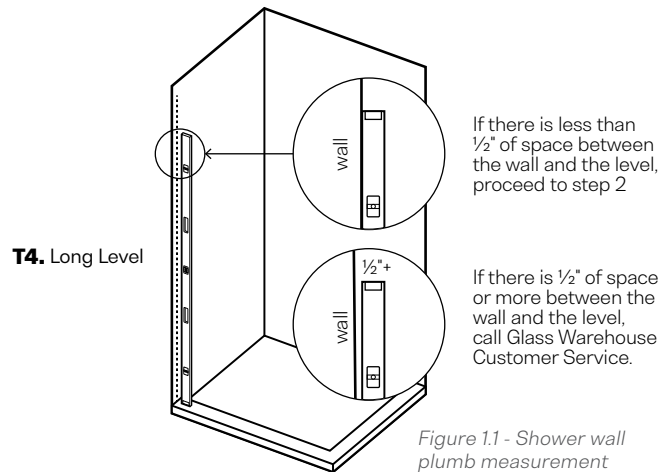

01

Before beginning installation, complete the following check to ensure proper fit and assembly

- Using a long level, determine if your wall is plumb. Measure the distance between the highest point of the Fixed Panel installation on the wall (**78"**) to the edge of the level.
- If there is $\frac{1}{2}$ " of space or more between the wall and the level, your wall is out of plumb. Please contact Glass Warehouse customer service for next steps before proceeding.
- If there is less than $\frac{1}{2}$ " of space between the wall and the level, proceed to **Step 02**.

WARNING

Only Use Parts Supplied by Glass Warehouse: Use only components and hardware supplied by Glass Warehouse. Substituting or modifying parts may compromise structural integrity, void the warranty, and/or result in improper installation.

02

Inspect all components

- Unpack the enclosure and verify that all required components and hardware are included according to the parts list. Verify that all parts are complete. (e.g., grub screws have rubber tips, plastic inserts are included with Floor Bracket, correct number of screws included, etc.).
- If any parts are missing or damaged, **DO NOT BEGIN INSTALLATION**.

Contact Glass Warehouse Customer Support for assistance and replacement parts.



Have Questions? Need Some Help?

Contact Us!

Email: inquiries@GlassWarehouse.us

Phone: (760) 536-3640

WARNING

Check Before You Install: Skipping the Owner's Manual or installation video can lead to incorrect assembly, or glass breakage.

03

Before beginning installation, complete the following checks to ensure proper fit and assembly

- a. Do not begin installation until you have thoroughly reviewed the Owner's Manual and installation video. These materials contain critical safety and alignment information required for a successful installation. Always review both in full before you begin.



Watch the video: View our animation video to assist your installation of the shower enclosure:

<https://qr.glasswarehouse.us/gw-f-rad-34-40>

WARNING

Save Cardboard Packaging for Installation: Always place glass panel on cardboard or other protective surfaces during installation. Failure to use protective surfaces can cause glass to chip, crack, or shatter, creating sharp edges. Improper handling of glass can result in death or serious injury.

04

Save cardboard packaging

- a. When opening the Fixed Panel (**A.**) packaging, carefully remove all components but Do **NOT** discard the cardboard packaging. It provides essential protection for the glass panels during installation. Do **NOT** Place glass directly on tile, concrete, or other hard surfaces. This can result in chipping, cracking, or breakage that is not covered under warranty.

NOTICE

Glass Certification Stamp : All Glass Warehouse panels include a tempered safety glass certification stamp located in one corner of each panel.

05

Locate glass certification stamp on glass panels

- a. Install all panels with the stamp positioned in the bottom corner closest to the wall where it will be less visible.
- b. The certification stamp is baked into the glass during the tempering process and cannot be removed.

Installation Steps

WARNING

For Fiberglass Walls: When installing on fiberglass walls, ensure a stud is directly behind the panel mounting location. Failure to do so may result in structural instability, and/or damage to the enclosure.

NOTICE

Reversible Installation: This panel is fully reversible and can be installed on right or left hand wall as needed.

Tip: For easy removal, marking with a pencil is recommended

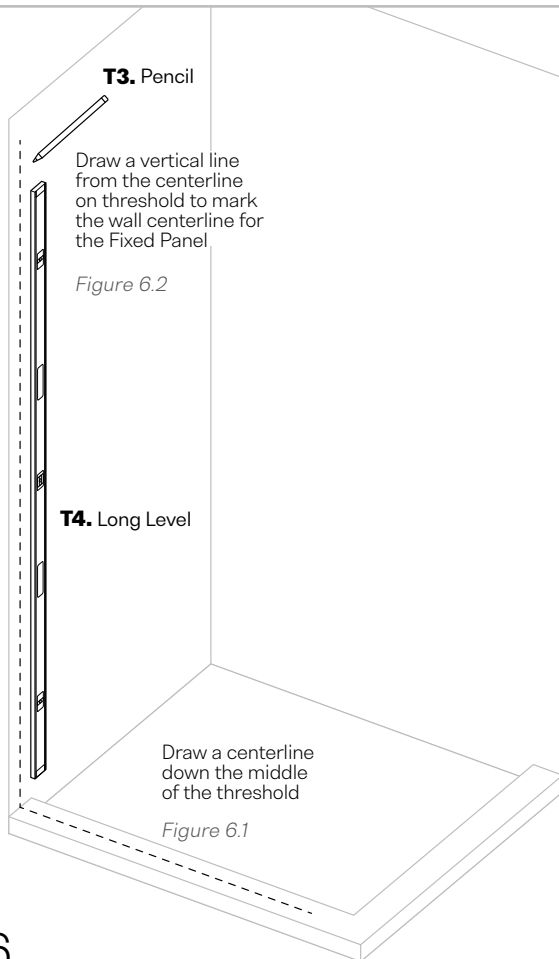

06

Mark Wall and Threshold for Fixed Panel

- Measure half the width of the threshold to determine the midpoint. This is the location of your center line.
- Draw a line along the threshold's surface to mark the center (Fig 6.1).
- Extend this line vertically up the wall using the long level (T4). This vertical line is the center line for the Fixed Panel (A.) and Wall Clips (B.) (Fig. 6.2).

NOTICE

Installing on Grout: Marks can be moved $\frac{1}{2}$ " up or down to avoid drilling into grout.

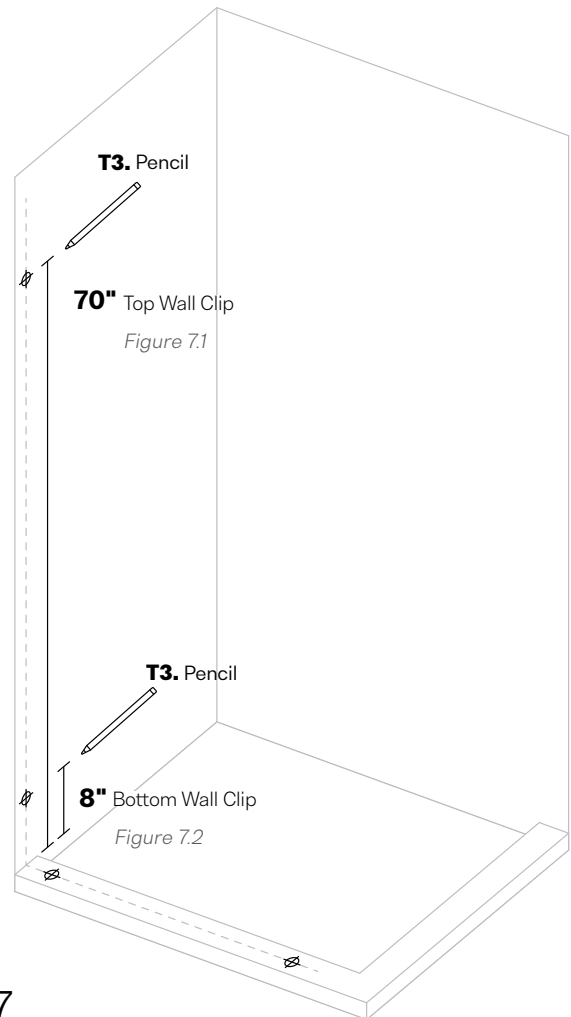

07

Mark Wall Clip installation positions

- On the vertical wall line, mark **70"** up from the shower base threshold for the top Wall Clip (B.) (Fig. 7.1).
- Mark **8"** up from the shower base threshold for the bottom Wall Clip (B.) (Fig 7.2).

WARNING

For Fiberglass Walls: When installing on fiberglass walls, ensure a stud is directly behind the panel mounting location. Failure to do so may result in structural instability, and/or damage to the enclosure.

NOTICE

Pilot Hole: A $\frac{1}{8}$ " tile drill bit can be used to create pilot holes for a tiled enclosure, but this is optional.

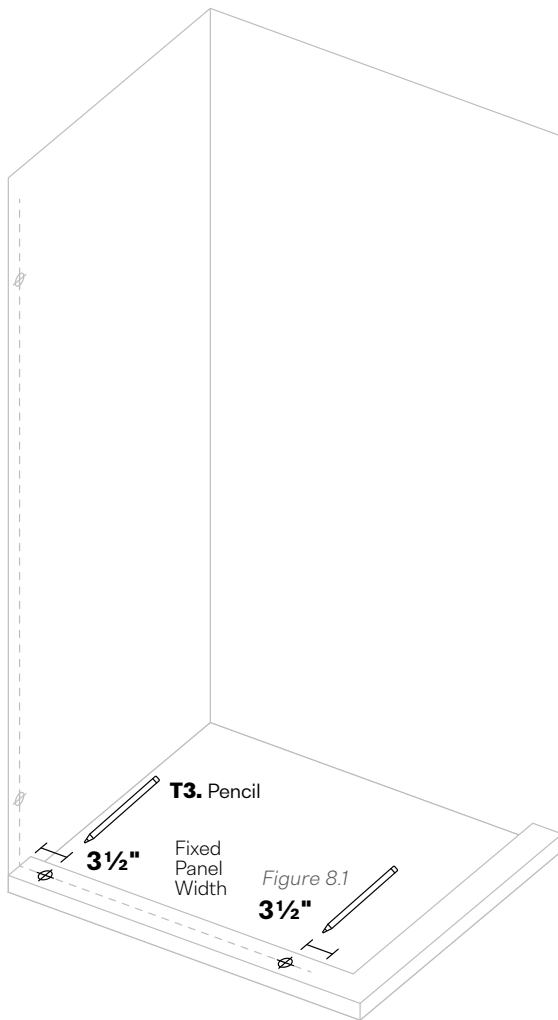

08

Mark Bottom Clip or Rubber Block Installation Position

- Measure the width of the Fixed Panel (A.) and subtract $3\frac{1}{2}$ ".
- From the wall, measure out this distance along the shower base threshold and mark it on the centerline. This establishes the placement for the Bottom Clip (B.) or Rubber Block (F.) (Fig 8.1).

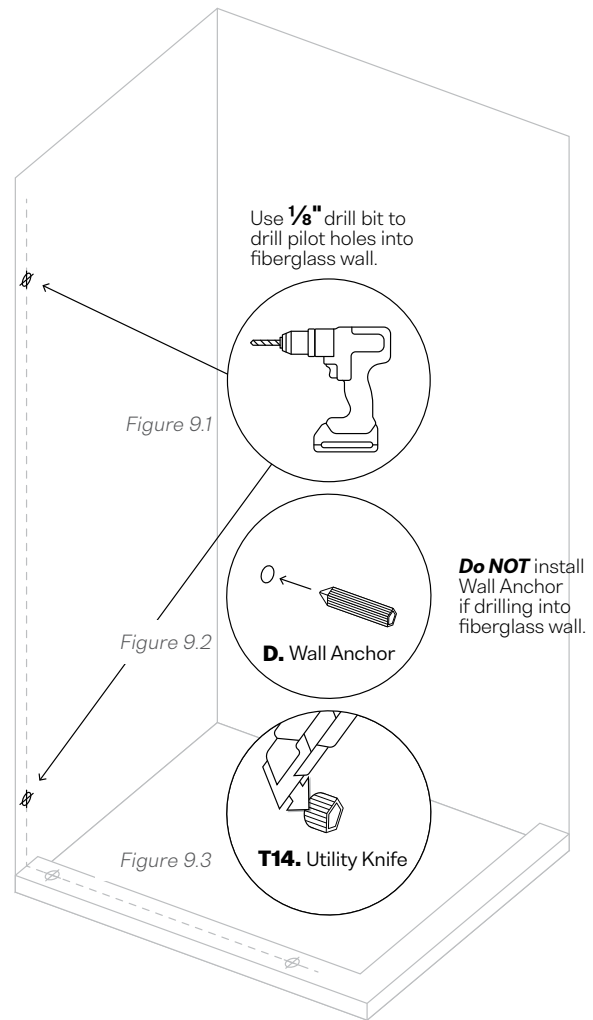

09

Drill wall holes and install Wall Anchors

- Using a $\frac{1}{4}$ " drill bit (T10), drill holes at the marked Wall Clip (B.) locations on the wall (Fig. 9.1).
- Insert the provided Wall Anchors (D.) into each hole until fully seated (Fig. 9.2).
- Use a Utility Knife (T14.) to trim any excess Wall Anchor (D.) protruding from the hole so the Wall Clips (B.) sit flush against the wall (Fig. 9.3).
- For Fiberglass Walls:** Use a $\frac{1}{8}$ " Drill Bit (T9.) for pilot holes. **Do NOT** use the Wall Anchors (D.). Instead, attach the Wall Clips (B.) directly to the fiberglass using the provided 5mm Screws (C.).

WARNING

Grub Screws: Ensure all grub screws in the wall clips include rubber tips to prevent contact damage to the glass panel. If any grub screws are missing rubber tips, do not proceed. Contact Glass Warehouse for replacement parts: inquiries@glasswarehouse.us

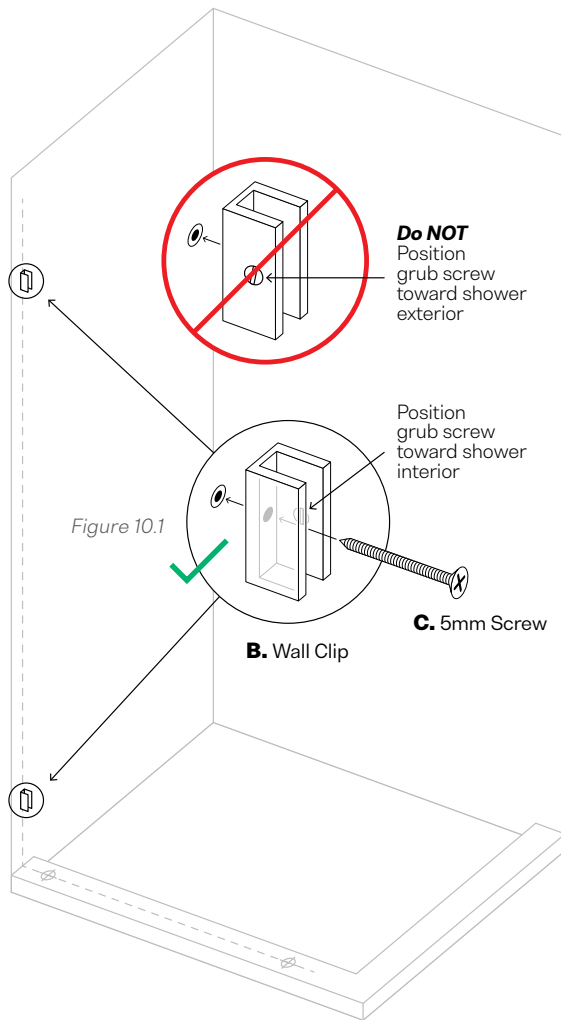

NOTICE

Third Clip Installation: If you are not drilling into the shower base and plan to use Rubber Blocks instead of the bottom clip **Go To Step 15.**

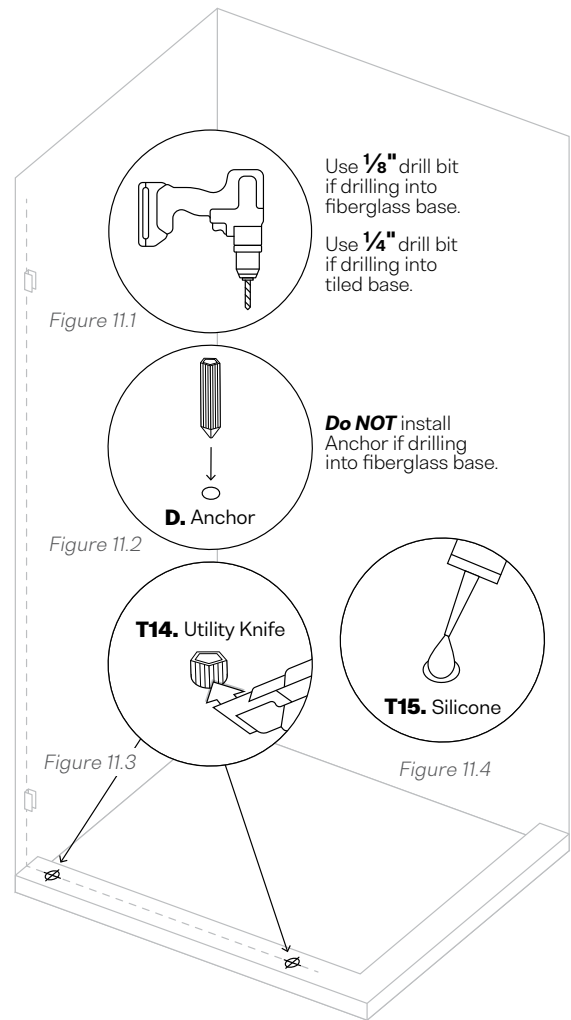

10

Install Wall Clips

- Place each Wall Clip (**B.**) over the drilled holes.
- Drill in the provided 5mm Screws (**C.**) to fasten the Wall Clips (**B.**) to wall.
- Ensure that the grub screws on each Wall Clip (**B.**) face the shower interior (Fig 10.1).
- Confirm that all Wall Clips (**B.**) are tightly secured and flush with the wall surface.
- Once installed, Wall Clip (**B.**) should not be able to spin or move freely.

11

Prepare Bottom Clips or Rubber Blocks Option

- Skip to **Step 15** if you are not drilling into the shower base and plan to use Rubber Blocks (**F.**) instead of the Bottom Clips (**B.**).
- For Fiberglass Bases:** Use a $\frac{1}{8}$ " drill bit to drill holes (Fig 11.1). **Do NOT** use a Wall Anchor (**D.**), secure the Bottom Clips (**B.**) directly into the fiberglass.
- For Tiled Thresholds:** Use a $\frac{1}{4}$ " tile drill bit to drill holes (Fig 11.1). Insert Wall Anchor (**D.**) (Fig 11.2) and trim any excess flush with Utility Knife (**T14.**) (Fig 11.3).
- Apply a dab of Silicone (**T15.**) into drilled holes before setting the Bottom Clips (**B.**) to prevent moisture intrusion and corrosion (Fig 11.4).

⚠ WARNING

Inspect Grub Screws: Ensure grub screw in Bottom Clip includes rubber tip to prevent contact damage to the glass panel. If any grub screws are missing rubber tips, do not proceed. Contact Glass Warehouse for replacement parts: inquiries@glasswarehouse.us

Use Rubber Blocks: Missing or misplaced rubber blocks can cause glass edge stress or breakage, potentially resulting in serious injury or death.

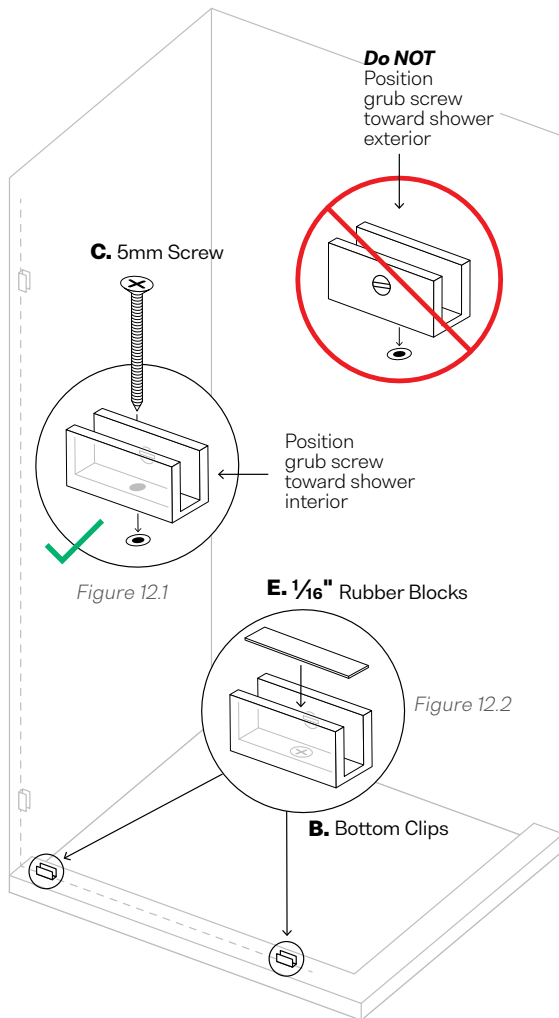

12

Install Fixed Panel Bottom Clips

- Install Bottom Clips (**B.**) in the drilled locations. Use the provided 5mm Screws (**C.**) (Fig 12.1).
- Insert 1/16" rubber blocks (**E.**) inside Bottom Clips (**B.**) to protect the Fixed Panel (**A.**) edge during installation (Fig 12.2).
- Once installed, ensure the Bottom Clips (**B.**) do not spin or move.

⚠ WARNING

Use Two People: Always use two people and handle tempered glass panels carefully. Improper lifting or installation can cause shattering, serious injury, or death.

Additional Rubber Blocks: Use additional Rubber Blocks (to raise or lower) and level Fixed Panel. Installing the Fixed Panel out of level can cause glass edge stress, breakage, or misalignment.

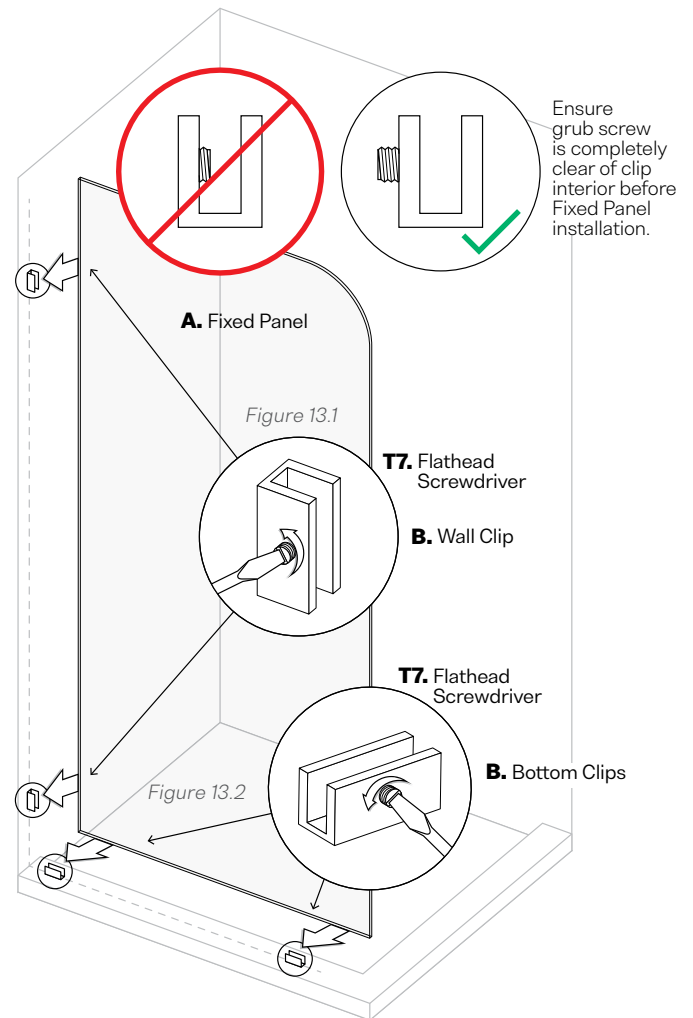

13

Set Fixed Panel into place with Bottom Clips

- Use a Flat Head Screwdriver (**T7.**) to loosen the grub screws in Wall Clips (**B.**) (Fig. 13.1) and Bottom Clips (**B.**) (Fig. 13.2) so they will not interfere with placing the Fixed Panel (**A.**).
- Carefully place the Fixed Panel (**A.**) into the Wall Clips (**B.**) and Bottom Clips (**B.**), ensuring it rests fully on the Rubber Blocks (**F.**).
- Ensure the panel is fully seated in Wall Clips (**B.**) and Bottom Clips (**B.**).

NOTICE

Rubber Block Option: If you are not drilling into the shower base and prefer the Rubber Blocks option instead of using the Bottom Clip, **continue below:**

WARNING

Check Rubber Blocks: Always verify Rubber Blocks are stable, aligned, and fully supporting the glass. Improperly positioned or uneven Rubber Blocks can place pressure on the glass edges, causing the tempered glass to crack or shatter without warning.

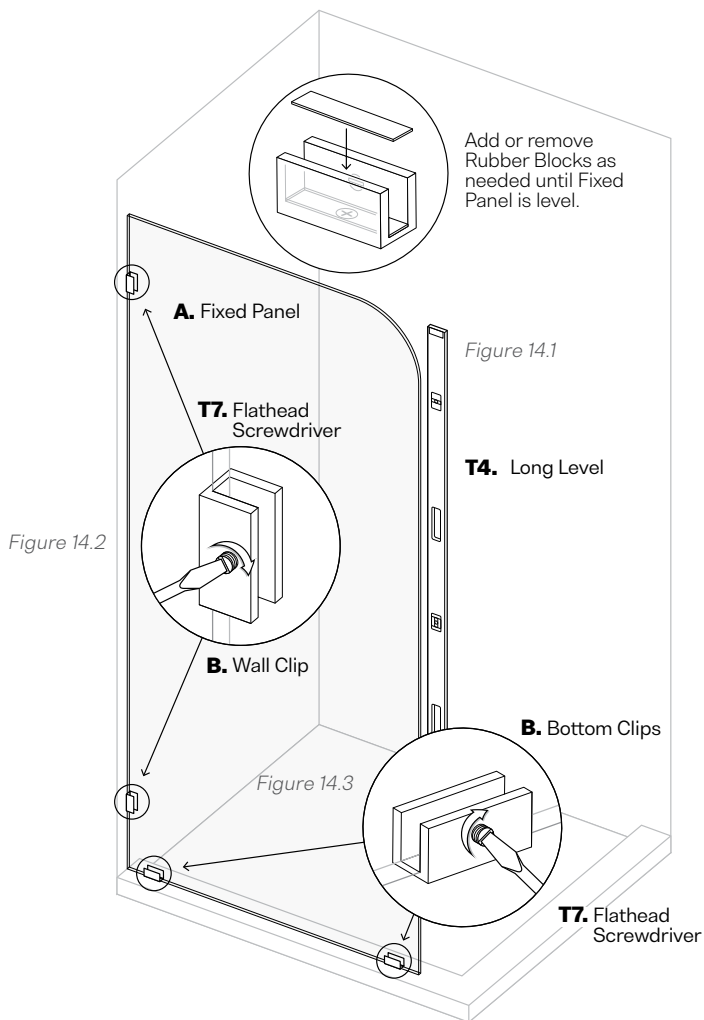

14

Complete Fixed Panel installation with Bottom Clips

- Use a Long Level (**T4.**) to confirm the Fixed Panel (**A.**) is perfectly level and seated securely within all Clips. If not level, add additional Rubber Blocks (**F.**) in Bottom Clips (**B.**) (Fig. 14.1) or on threshold until level.
- Tighten grub screws in Wall Clips (**B.**) (Fig. 14.2) and Bottom Clips (**B.**) (Fig. 14.3) to secure Fixed Panel (**A.**) in place.
- Continue to **Step 19.**

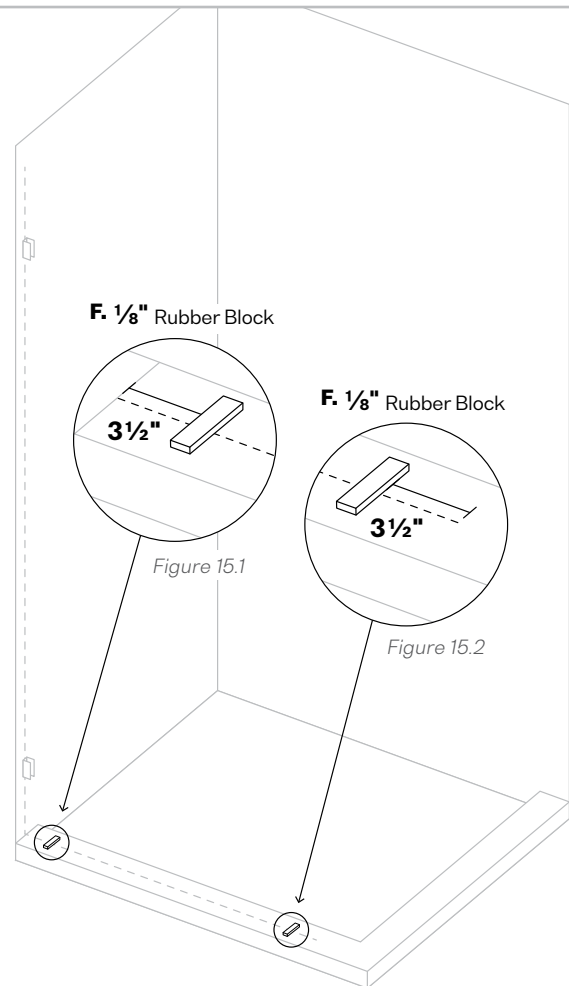

15

Install Rubber Blocks (No Drilling Option)

- Measure **3 1/2"** from the wall, mark this location, and place the first **1/8"** thick Rubber Block (**F.**) on the threshold (Fig 15.1).
- Measure the Fixed Panel (**A.**) width, subtract **3 1/2"**, and from the wall. Mark that distance on the threshold. Place the second **1/8"** thick Rubber Block (**F.**) on the threshold at this location (Fig 15.2).
- Ensure both Rubber Blocks (**F.**) are aligned and level. The Fixed Panel (**A.**) will rest directly on these supports.

WARNING

Use Two People: Always use two people and handle tempered glass panels carefully. Improper lifting or installation can cause shattering, serious injury, or death.

Additional Rubber Blocks: Use additional Rubber Blocks (to raise or lower) and level Fixed Panel. Installing the Fixed Panel out of level can cause glass edge stress, breakage, or misalignment.

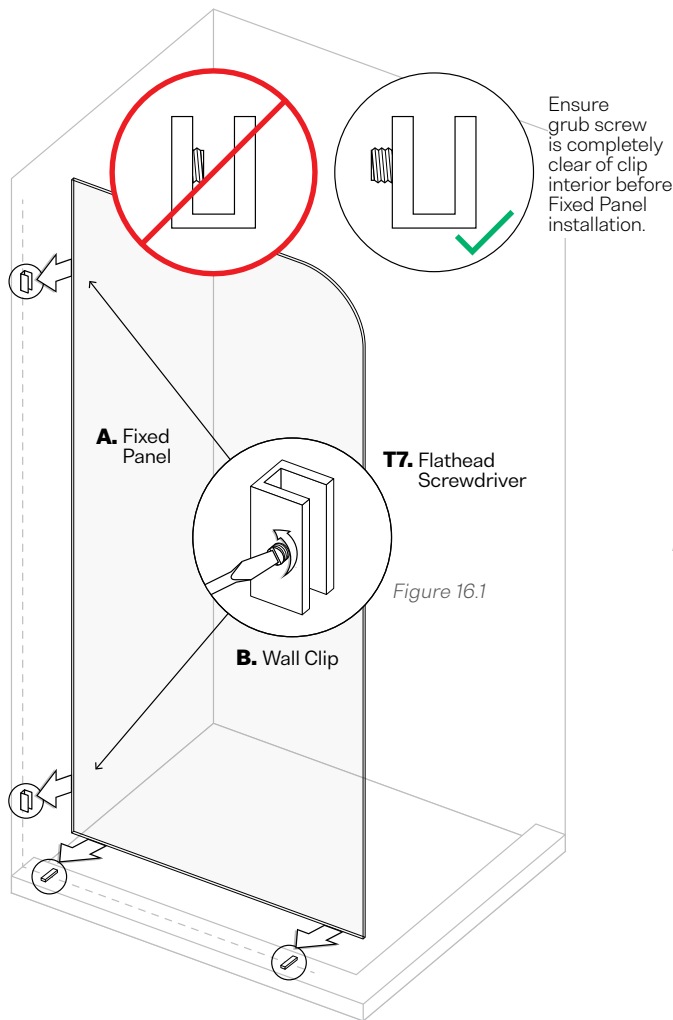

16

Set Fixed Panel into place with Rubber Blocks

- Use a Flat Head Screwdriver (**T7.**) to loosen the grub screws in Wall Clips (**B.**) (Fig. 16.1) so they will not interfere with placing the Fixed Panel (**A.**).
- Carefully place the Fixed Panel (**A.**) into the Wall Clips (**B.**) and onto Rubber Blocks (**F.**).
- Ensure the panel is fully seated in Wall Clips (**B.**) and resting securely on the Rubber Blocks (**F.**).

17

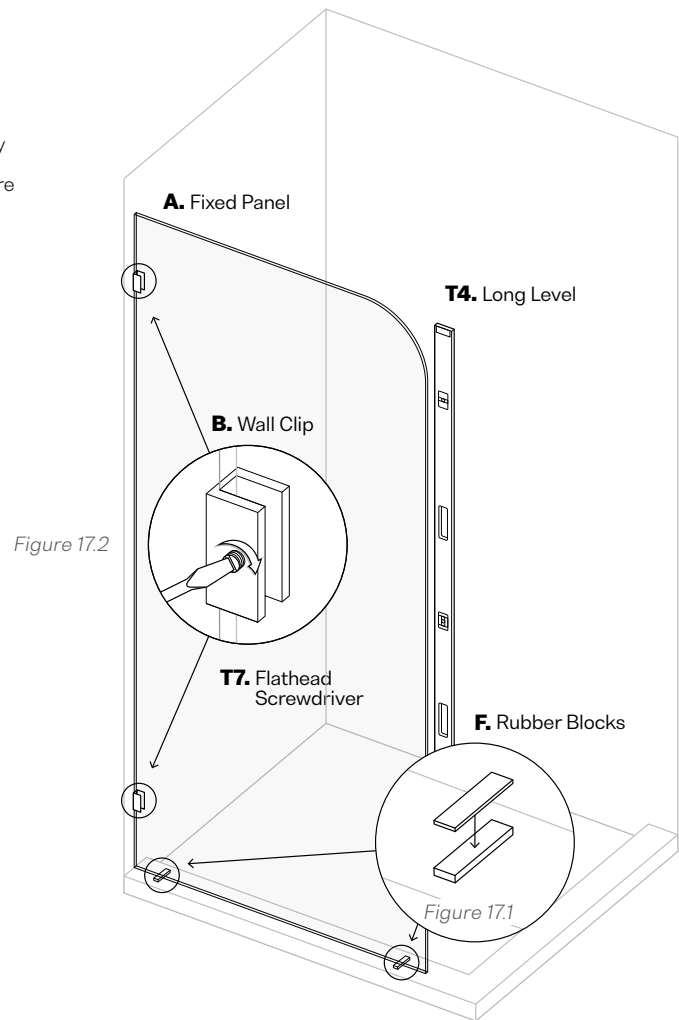

17

Complete Fixed Panel installation with Rubber Blocks

- Use a long level (**T4.**) to confirm the Fixed Panel (**A.**) is perfectly level and seated securely on Rubber Blocks (**F.**). If not level, add additional Rubber Blocks on threshold until level (Fig 17.1).
- Tighten grub screws in Wall Clips (**B.**) to secure the Fixed Panel (**A.**) in place (Fig 17.2).

WARNING

Trim Rubber Blocks: Use caution when cutting near the glass or shower base. Do not force the blade or cut too close to the panel edge, as this may chip the glass or damage the base surface.

NOTICE

Do Not Silicone Clips: Do not apply Silicone to the Clips interiors or surface. In the event the glass panel needs to be replaced or removed for other repairs, it is easily reinstalled.

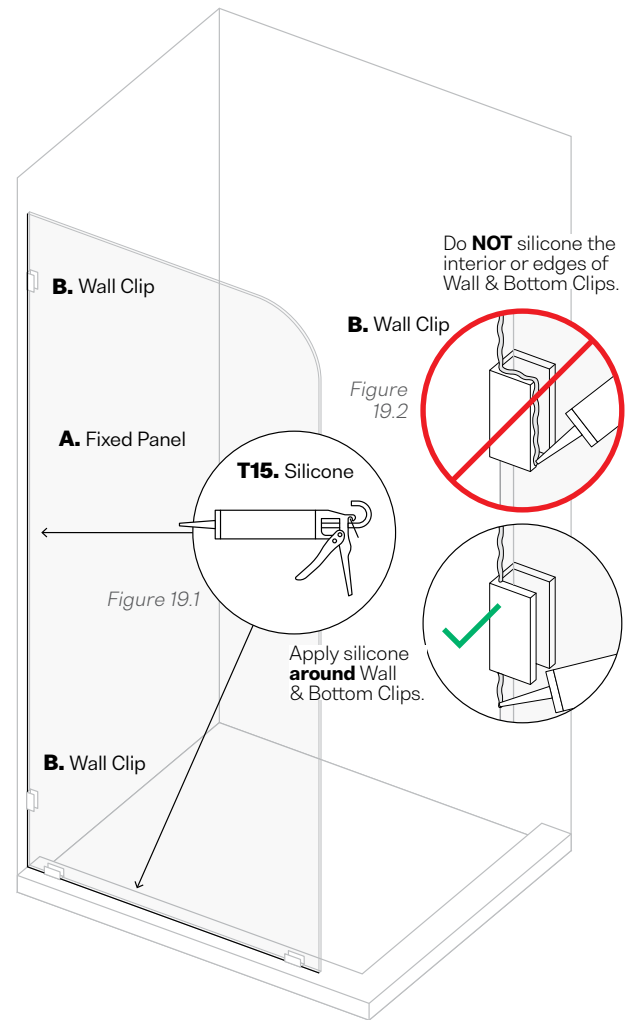
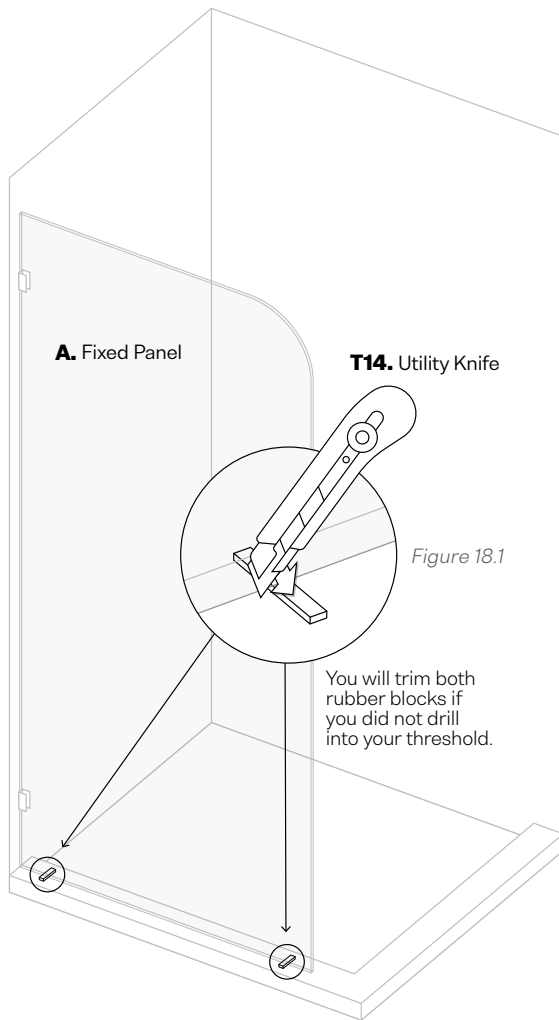

18

Trim Rubber Blocks

- Use Utility Knife (**T14.**) to carefully trim $\frac{1}{8}$ " Clear Rubber Blocks (**F.**) on both sides of Fixed Panel (**A.**) (Fig 18.1).
- Leave the Clear Rubber Blocks (**F.**) in place beneath the Fixed Panel (**A.**). Do not remove them.
- If two Rubber Blocks (**F.**) were used instead of Bottom Clip, trim the excess from both blocks on each side of Fixed Panel (**A.**).

19

Apply Silicone to Seal Fixed Panel

- Apply silicone along the wall and floor surfaces adjacent to the Fixed Panel (**A.**). Be sure to seal both the inside and outside edges, ensuring the gap between the glass and tile is completely filled (Fig 19.1).
- Do **NOT** silicone the interior edges of Wall and Bottom Clips (**B.**). Apply silicone around Clips (Fig. 19.2).

⚠ WARNING

Let Silicone Cure: Do not use the shower before the silicone has set and cured (36 hours minimum). Premature exposure to water or pressure may compromise the seal, cause leaks, and/or damage to surrounding surfaces.

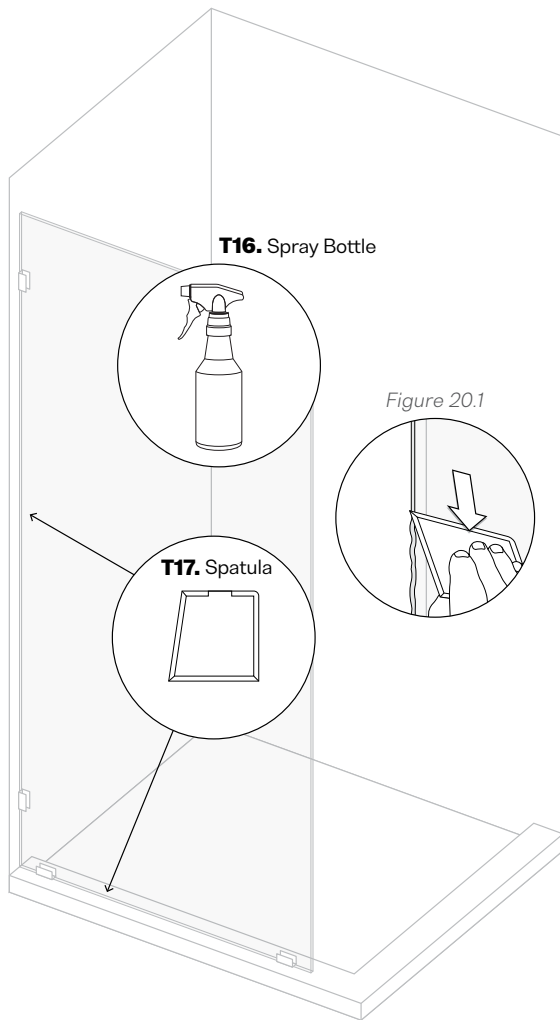

20

Smooth Silicone and remove residue

- a. Spray the Silicone with Water Bottle (T16.) and use a Spatula (T17.) to smooth texture (Fig. 20.1) and remove any excess residue for a clean finish.
- b. Allow the silicone to set and cure for **36** hours before using the shower.

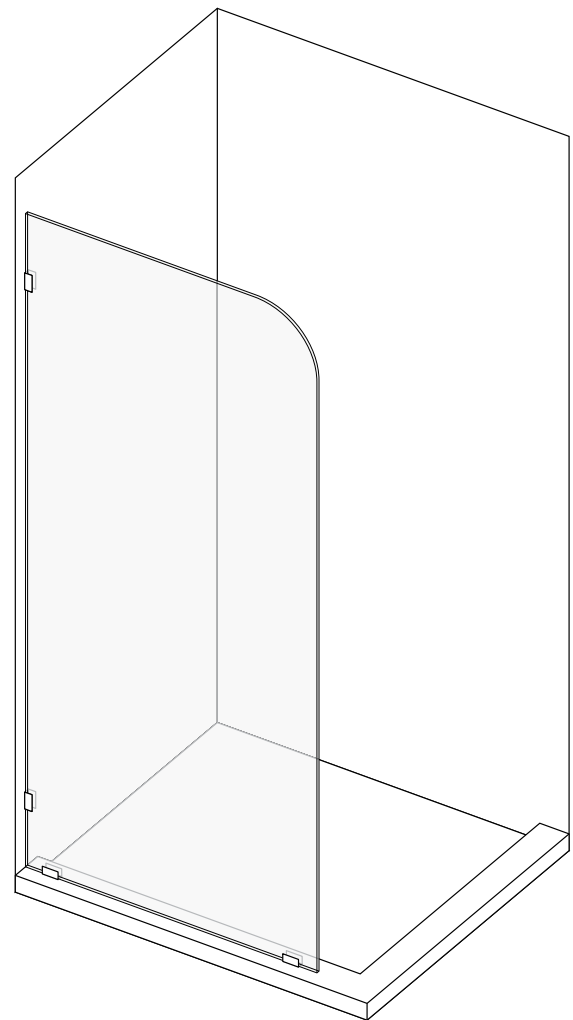

21

Once silicone has cured, you're done!

- a. To activate your product warranty, please follow the registration instructions located on the back cover of this installation guide.

Thank You for Your Purchase.

If, for any reason, you are having trouble with installation, or if the size of the product does not fit your designated space, please contact Glass Warehouse directly before returning it to the place of purchase, as we may be able to replace a panel or parts to better suit your space.

Glass Warehouse takes pride in providing quality products and customer service. We want to ensure your satisfaction with your purchase for years to come. With our extensive range of sizes, no matter what your measurements are, Glass Warehouse should be able to assist you!

If you have any questions, please do not hesitate to reach out to us. Thank you again for choosing Glass Warehouse!

Best Regards,

The Team at Glass Warehouse
Glass Warehouse, LLC
(760) 536 3640
inquiries@glasswarehouse.us

Hardware Care & Maintenance

Care & Maintenance

Your Glass Warehouse shower enclosure is designed for long-lasting performance and beauty. Regular cleaning and maintenance will help prevent buildup, protect finishes, and maintain smooth operation.

Metal Hardware

To maintain the luster and function of your hardware:

- Wipe all metal components dry after each use with a soft, non-abrasive cloth.
- Do not use cleaners containing ammonia, bleach, or acid. If accidentally used, rinse immediately and dry thoroughly to prevent peeling or corrosion.
- Clean stainless steel hardware weekly. When polishing, always wipe in the direction of the grain.
- Never use steel wool, wire brushes, or abrasive pads, as these can scratch or permanently damage the surface.
- If you notice noise, stiffness, or uneven movement, stop using the door immediately and check for debris, misalignment, or damage.
- Replace any worn or damaged hardware before resuming use.

Roller Assemblies (if applicable)

The roller system supports and guides your sliding door panel and must remain in good condition for safe operation.

- Inspect rollers monthly to confirm smooth, quiet movement and ensure all bolts and set screws are tight.
- Verify that the rollers remain properly aligned and seated on the guide rail.
- If you notice noise, stiffness, or uneven movement, stop using the door immediately and check for debris, misalignment, or damage.
- Replace any worn or damaged rollers before resuming use.
- Failure to maintain or replace damaged rollers can lead to glass instability and result in death or serious injury.
- Inspect roller guides regularly to confirm they are securely fastened and free of damage. If guide becomes loose, misaligned, or damaged, discontinue use of the door until the issue is corrected.
- Verify that the guides maintain the correct clearance between the door panel and the shower rod, as specified during installation.
- Ensure the door panel remains centered within the guides and does not contact surrounding hardware during operation.
- Failure to properly maintain roller guides can result in door instability and may lead to serious injury or death.



Have Questions? Need Some Help?

Contact Us!

Email: inquiries@GlassWarehouse.us

Phone: [760] 536-3640

Glass Care & Maintenance



EnduroShield makes cleaning easier and less frequent; however it is recommended that you continue to clean the surfaces regularly.

Maintaining the Treated Surface

For best results simply drying the glass with a squeegee or towel after each use will help keep the glass clean and reduce mineral spots forming. The glass needs to be cleaned every few weeks using a damp microfiber cloth and a mild detergent to break down soaps, oils, and conditioners on the glass. General glass cleaners are also suitable, however most of these are finishing agents rather than cleaners, and are an added expense that is not required.

Hard Water Maintenance

In hard water areas, or areas where water drops dry and leave a noticeable dust mark, a build of minerals may occur on the protective treatment. While these may not be removed as easily with the mild detergent, mild acids will often remove the marks quickly. As needed white vinegar should be used to wipe down the glass. Keep in mind the vinegar may be diluted with water, however dilution reduces the effectiveness.

Spray vinegar onto the glass and allow to soak for several minutes. This should dissolve any mineral deposits that have built up on the glass surface. A damp microfiber cloth should then be used to wipe over the surface. For extreme hard water areas we recommended using undiluted vinegar every week or so as a cleaning option to reduce this build up on the surface, rather than allowing the build up to continue over a long period of time.

Caution: Prohibited Products *Note these may damage the treatment and void any warranty

- Avoid the use of any abrasives or polishes including water spot removers, toothpaste, polishes, rough, or gritty substances
- Avoid the use of acids or alkalis that you would not want in contact with your skin for an extended period of time
- Avoid products such as Comet, Ajax, Jiff or Cerium Oxide which polish back the actual substrate
- Avoid the use of any harsh or chemical cleaners, with correct maintenance these are never required

Approved Cleaning Products

The below products have been tested for compatibility with EnduroShield, however there are no specific products that must be used. We feel you should not be required to purchase extra products in order to keep your glass clean. With correct maintenance, all you need for clean glass beyond 10 years is a squeegee, a mild liquid dish soap, and white vinegar.

Any product that does not fall into the prohibited categories listed above will be fine, and below is a short list of acceptable products:

- Windex
- SprayWay (or other alcohol based foaming cleaners)
- Scrubbing Bubbles (or other automatic leave-to-dry daily shower cleaners)
- 7th Generation, Dawn (or other mild eco friendly cleaners)
- CLR (Calcium Lime Rust)
- Mr. Clean Magic Eraser (when damp)

It should be noted that with any cleaner used on the EnduroShield surface a thorough rinse with clean water should follow immediately. Although these cleaners can be used, EnduroShield is designed to be an 'easy clean coating' that does not require harsh or toxic cleaning chemicals to maintain the surface effectively.

If for any reason the recommended maintenance has not been followed for some time, just as it took time for the build up to occur, it will take time to remove the debris from the protected glass surface. This can most commonly be achieved using undiluted white vinegar dampened on a Magic Eraser, or CLR on a Magic Eraser. Depending on the severity of the build up this may take multiple attempts, but once the glass is clean again it will perform like new. Should you have any queries regarding the cleaning of your treated surfaces please contact EnduroShield.

tel: 805 617 4609
email: salesusa@enduroshield.com
www.enduroshield.com



More Than Just a Warehouse

GLASSWAREHOUSE
GLASSWAREHOUSE.US

First, We Brought the World
High-Quality Affordable Glass
Shower Doors & Enclosures.

Now, Our Expanding Line of
Products Includes Glass Railing
Solutions, Mirrors, Medicine
Cabinets and More.

© 2025 Glass Warehouse, All Rights Reserved

Exclusive Limited Warranty Terms & Conditions.

This Limited Lifetime Warranty ("Warranty") is effective as of APRIL 6, 2026

PLEASE READ THE WARRANTY TERMS AND CONDITIONS BEFORE PURCHASING AND BEFORE INSTALLING OR RESELLING YOUR GLASS WAREHOUSE PRODUCT. BY PURCHASE, INSTALLING, AND OR RESELLING THE GLASS WAREHOUSE PRODUCT, YOU ARE CONSENTING TO BE BOUND BY THE FOLLOWING TERMS AND CONDITIONS.

Glass Warehouse, LLC ("Seller") provides this Warranty to the business or individual ("Buyer") who purchases a Glass Warehouse product ("Product") directly from Seller or from an authorized reseller, including without limitation, shower kits, railing hardware, medicine cabinets, and mirrors. If Buyer is a licensed and fully insured professional and Buyer installs the Product in the residence of one of Buyer's customers ("Customer"), Buyer may pass this Warranty through to such Customer. In each case, this Warranty shall extend only to the original Buyer or Customer at the time of installation and shall expire if the original Buyer or Customer no longer owns or occupies the residence at which the Product is first installed. This Warranty will not apply to any subsequent owners or occupants of the residence. "Products" do not include, and this Warranty specifically excludes: (i) any products sold by Glass Warehouse under brand names other than Glass Warehouse; (ii) any third-party products distributed or sold by Glass Warehouse that are not incorporated into a Glass Warehouse Product.

Limited Lifetime Warranty for Glass

With respect to any glass components of the Product, Seller warrants to Buyer that for the lifetime of the Product ("Glass Warranty Period"), that such components (excluding seals) will materially conform to Seller's published specifications and will be free from material defects in material and workmanship. Warranty for any part in oil rubbed bronze or matte black finish shall be limited to one (1) year. With respect to any Product used in commercial, industrial, or non-residential uses, including without limitation hotels, casinos, and apartments, the Glass Warranty Period is one (1) year. For mirrors, including medicine cabinets with mirrors, the Glass Warranty Period is one (1) year. For glass railings, the Glass Warranty Period is three (3) years. The Glass Warranty Period with respect to the outer coating of any glass component, such as an Enduroshield coating, is five (5) years.

Limited 5-Year Warranty for Hardware

With respect to any hardware components of the Product, Seller warrants to Buyer that for a period of five (5) years from the date of Buyer's purchase of the Product ("Hardware Warranty Period"), that such components (excluding seals) will materially conform to Seller's published specifications and will be free from material

defects in material and workmanship. With respect to any Product used in commercial, industrial, or non-residential uses, including without limitation hotels, casinos, and apartments, the Hardware Warranty Period is one (1) year. For mirrors, including medicine cabinets with mirrors, the Hardware Warranty Period is one (1) year. For railings, the Hardware Warranty Period is one (1) year. The Glass Warranty Period and Hardware Warranty Period are referred to together as the "Warranty Period."

While stainless steel is resistant to corrosion, it is not corrosion or rust-proof. Environmental conditions including, but not limited to, exposure to chemicals, salt air, pollution, and high humidity may cause surface discoloration or rust. Regular cleaning and maintenance is required to maintain the appearance and integrity of stainless steel products. Seller makes no warranty against and shall not be liable for any claims related to surface rust, discoloration, or corrosion of stainless steel components.

Warranty Terms and Conditions

This Warranty shall be voided if the Product (i) has been subjected to abuse, misuse, neglect, negligence, accident, improper testing, improper installation, improper cleaning (such as use of abrasive cleaners), improper storage, improper handling, abnormal physical stress, abnormal environmental conditions, or use or installation contrary to any instructions or guidelines issued by Seller; (ii) has been altered, repaired, or reconstructed by anyone other than Seller; (iii) was installed by anyone other than a fully insured and licensed professional; (iv) was not installed according to Glass Warehouse's published installation instructions or guidelines; (v) is installed or used outside of the US or Canada; or (vi) has been used with any third-party hardware or product that has not been previously approved in writing by Seller. This Warranty shall not apply to normal wear and tear. With respect to Products advertised by Glass Warehouse for outdoor use, this Warranty specifically excludes damage caused by extreme weather events.

WARNING: INSTALLATION OF GLASS PRODUCTS (I.E., SHOWER AND TUB DOORS) BY AN UNLICENSED OR INEXPERIENCED INSTALLER MAY RESULT IN GLASS BREAKAGE, DAMAGE TO PROPERTY, SERIOUS INJURY OR DEATH.

Neither Buyer, nor any other person is permitted to make any affirmation, representation, or warranty other than those contained in this Warranty. Any affirmation, representation, or warranty other than those contained in this Warranty shall not be enforceable against Seller or any other person. Seller reserves the right to modify this Warranty at any time, it being understood that such modifications will not alter the terms and conditions applicable at the time of sale of the products in question.

Please register your information to activate your warranty, <https://qr.glasswarehouse.us/GW-warranty>

Claims Process and Remedies:

All Warranty claims are subject to review and confirmation by Seller, and Seller reserves the right to inspect the installation to confirm the validity of the Warranty claim. To submit a Warranty claim, Buyer must:

1. Contact Seller’s customer service department within 30 days of discovering the defect. Contact information:

Phone: **+1(760) 536-3640**
Email: **inquiries@glasswarehouse.us**
<https://qr.glasswarehouse.us/GW-warranty>
2. Provide the following required documentation: (a) proof of purchase; (b) detailed description of the defect, including photographs; (c) item part number.
3. A customer service representative will review the claim and may request additional information or schedule an inspection of the Product and/or installation. Buyer must cooperate fully with any requests for information or inspection.

Seller shall have no obligation to honor any Warranty claim that does not comply with the above claims process. If a Warranty claim is approved, Seller shall, in its sole discretion, either: (i) repair or replace such Product (or the defective part), in which case Seller shall cover shipping of the repair parts or replacement product; or (ii) refund the price paid by Buyer to Seller for such Product. Replacement parts and products will be covered by this Warranty for the remainder of the Warranty Period of the original Product. Seller may require that the Product be returned to Seller, at Seller’s expense. Except for any repairs made by Seller or its representatives as set forth above, Seller shall not pay for labor related to the Warranty claim, such as removal of the defective Product or installation of a replacement product. Seller’s warranty obligation shall be discharged upon tender of parts, replacement or repair of the Product. Buyer’s refusal to accept the tender terminates all warranty obligations and **VOIDS THIS WARRANTY.**

THE REMEDIES SET FORTH ABOVE SHALL BE BUYER’S SOLE AND EXCLUSIVE REMEDY AND SELLER’S ENTIRE LIABILITY FOR ANY BREACH OF THIS WARRANTY.

Disclaimer and Limitation of Liability:

EXCEPT FOR THE PRECEDING WARRANTY, SELLER MAKES NO WARRANTY TO BUYER WHATSOEVER WITH RESPECT TO THE PRODUCTS AND HEREBY DISCLAIMS ALL OTHER WARRANTIES, INCLUDING ANY (I) WARRANTY

OF MERCHANTABILITY; (II) WARRANTY OF FITNESS FOR A PARTICULAR PURPOSE; OR (III) WARRANTY AGAINST INFRINGEMENT OF INTELLECTUAL PROPERTY RIGHTS OF A THIRD PARTY; WHETHER EXPRESS OR IMPLIED BY LAW, COURSE OF DEALING, COURSE OF PERFORMANCE, USAGE OF TRADE OR OTHERWISE.

SELLER DISCLAIMS AND SHALL NOT BE LIABLE FOR ANY PERSONAL INJURIES OR DEATH TO ANY PERSON, INCIDENTAL DAMAGES, CONSEQUENTIAL DAMAGES, LOSS OF PROFITS, LOSS OF USE, LABOR OR MATERIAL CHARGES, OR ANY OTHER COSTS RELATING TO THE USE OR INABILITY TO USE THE PRODUCT OR REPLACEMENT PRODUCT OR RELATING TO THE APPLICATION OF THIS WARRANTY. IN NO EVENT SHALL SELLER’S AGGREGATE LIABILITY EXCEED THE PURCHASE PRICE OF THE PRODUCT.

SOME STATES LIMIT A MANUFACTURER’S ABILITY TO DISCLAIM CERTAIN WARRANTIES OR LIABILITIES AND THEREFORE SOME OF THE ABOVE DISCLAIMERS OR LIMITATIONS OF LIABILITY MAY NOT APPLY TO YOU.

Warranty Service

To activate your limited lifetime warranty, please visit: **<https://qr.glasswarehouse.us/GW-warranty>**



Please register your information within 30 days of purchase to complete the activation of your warranty.

Contact Technical Support:

**Monday – Friday 8am – 5pm PST
Technical Support: [+1\(760\) 536-3640](tel:+17605363640)**