

ASSEMBLY INSTRUCTION

LSJ029

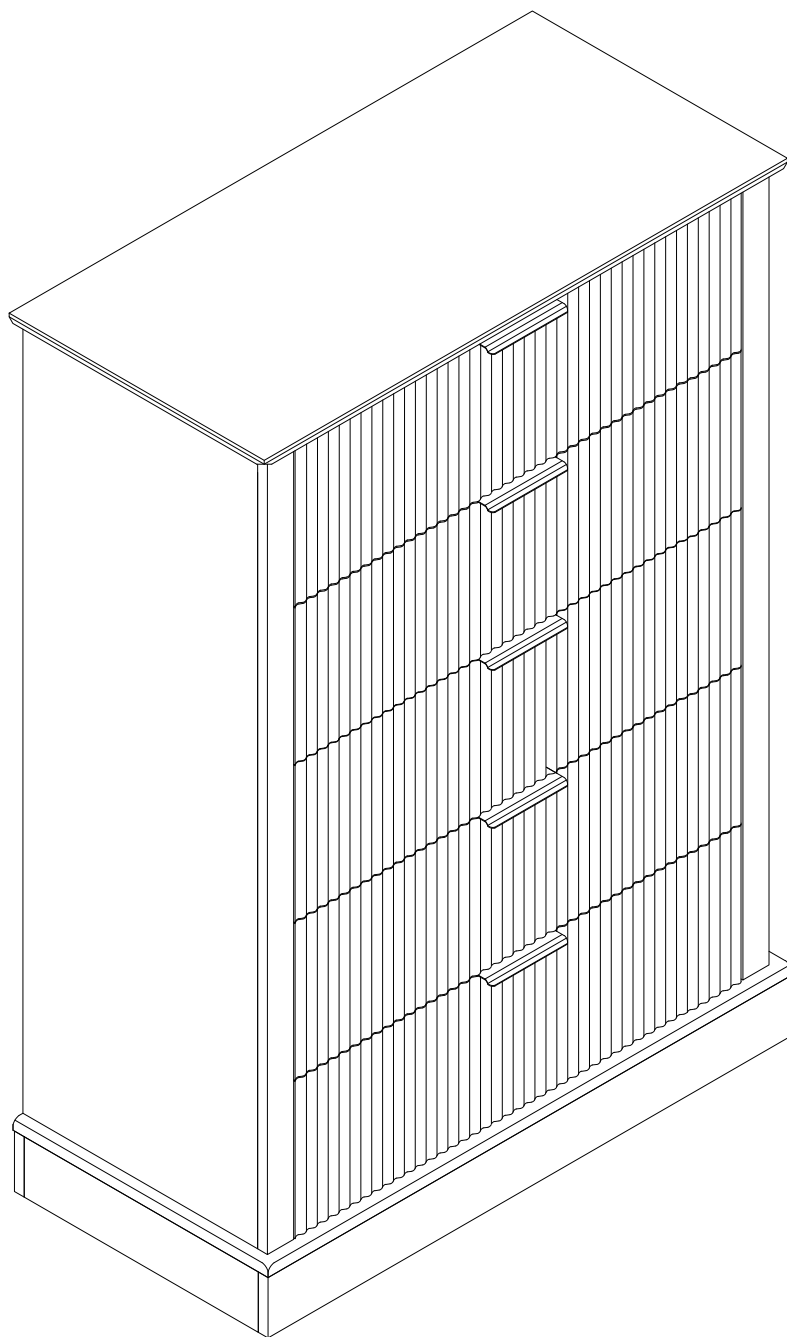

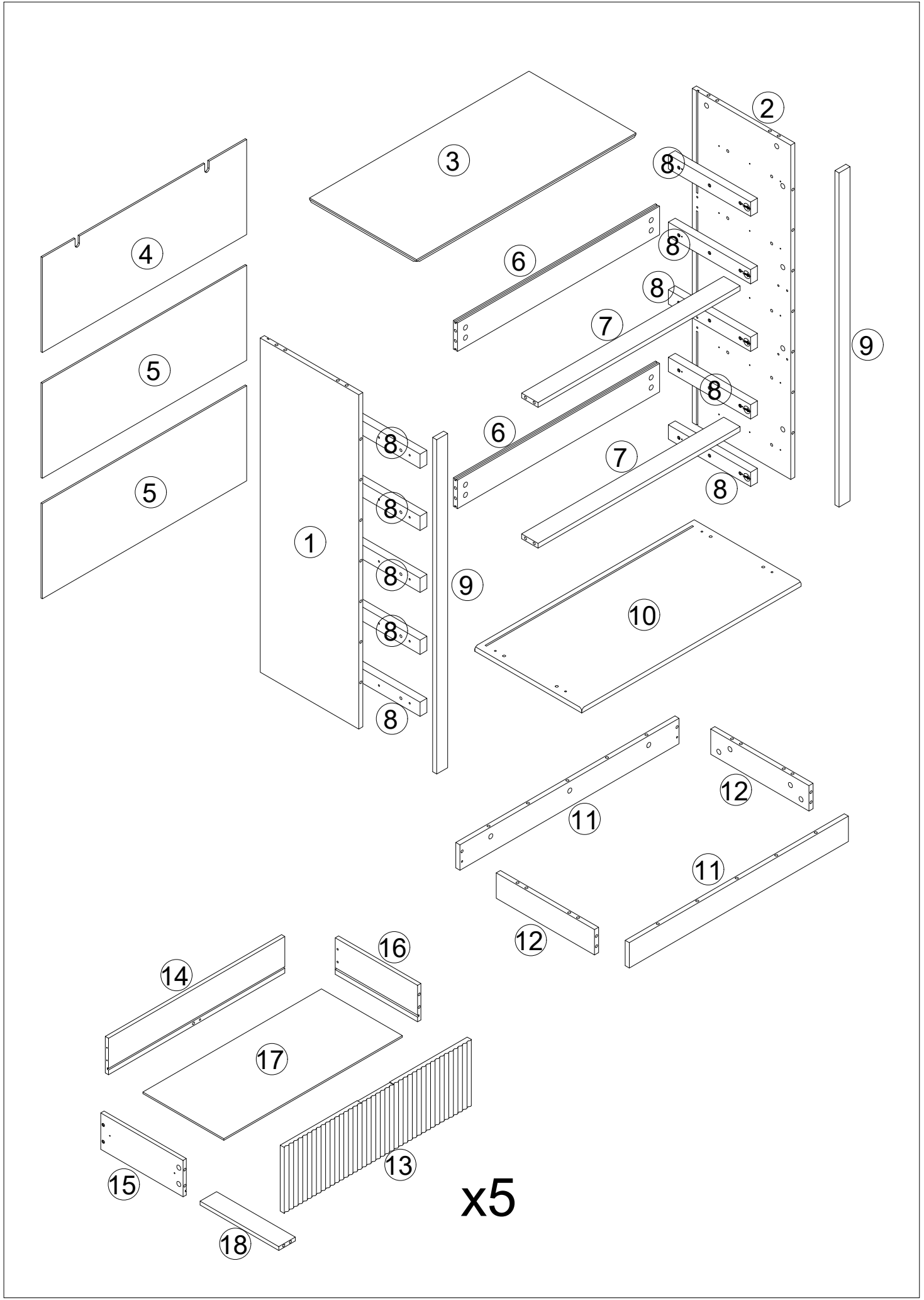

x5

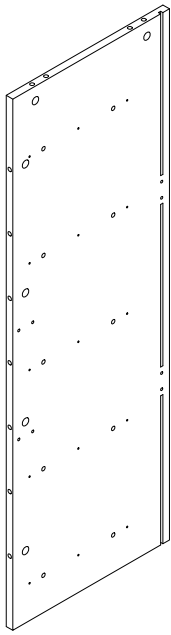

① x 1

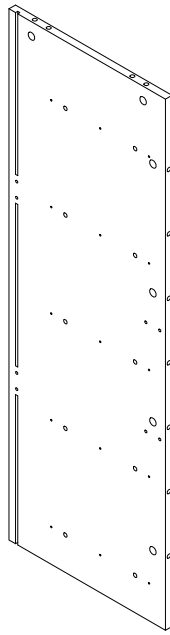

② x 1

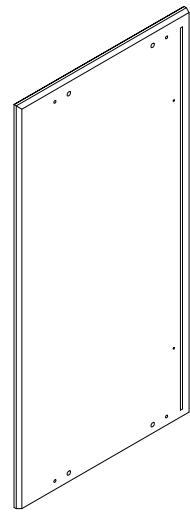

③ x 1

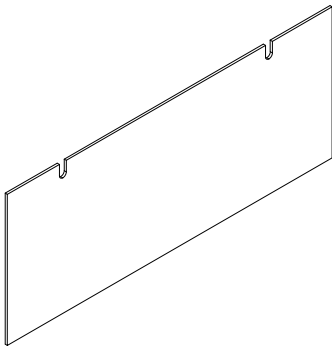

④ x 1

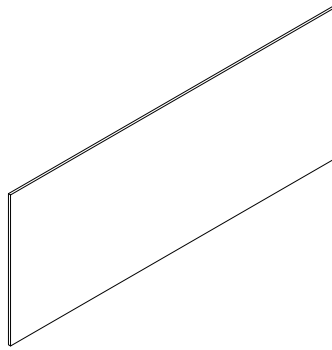

⑤ x 2

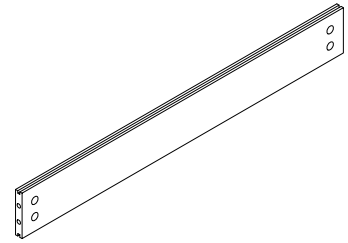

⑥ x 2

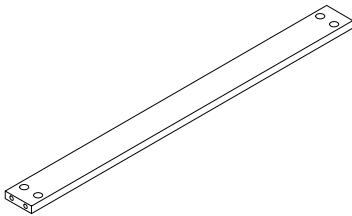

⑦ x 2

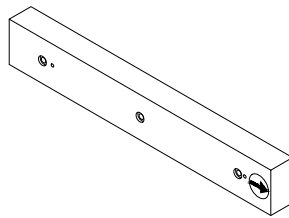

⑧ x 10



⑨ x 2

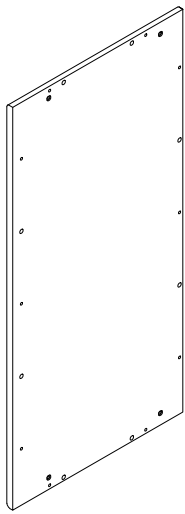

⑩ x 1

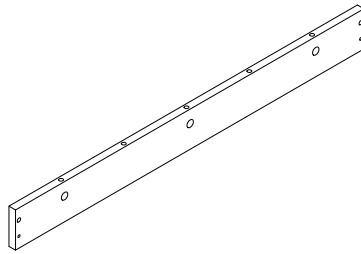

⑪ x 2

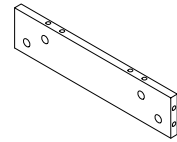

⑫ x 2

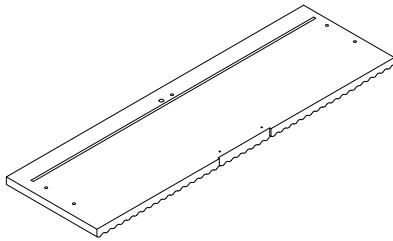

⑬ x 5

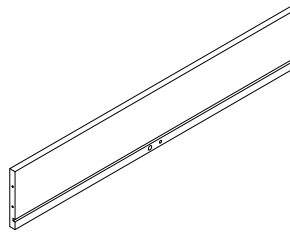

⑭ x 5

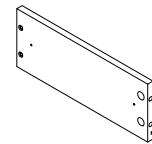

⑮ x 5

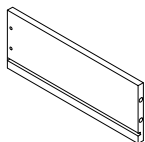



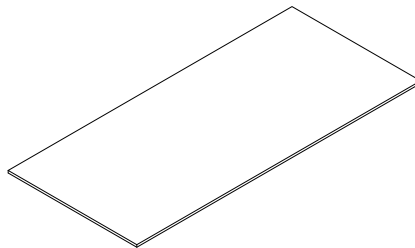



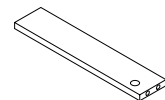



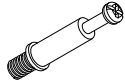

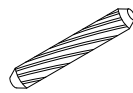
⑯ x 5

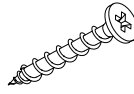

⑰ x 5

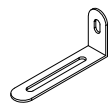

⑱ x 5

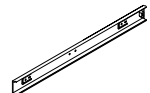
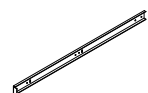
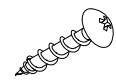
 Φ6x35mm A x 67+2	 Φ15x9.5mm B x 67+2	 Φ6x30mm C x 56+2	 M3.5x12mm D x 50+2	 M4x14mm E x 2	 M3x14mm F x 10+1
 M4x35mm G x 31+2	 Φ6x30mm H x 2	 I x 2	 J x 5	 K x 6	 L x 10+1
 M x 10	 N x 10	 M4x30mm O x 30+2			

Step 1

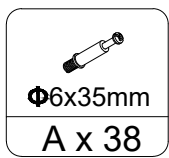
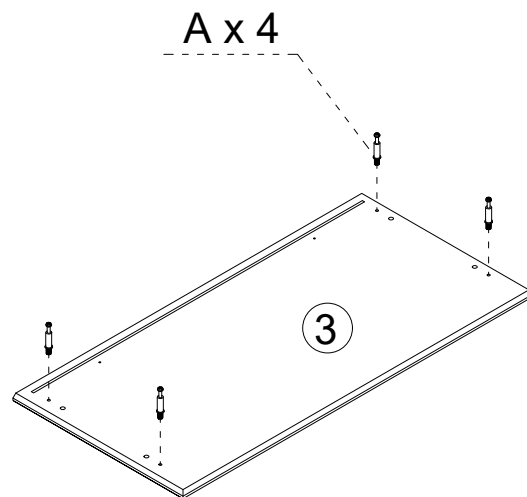
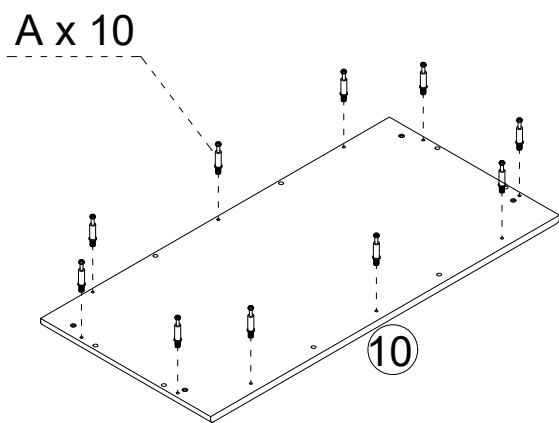
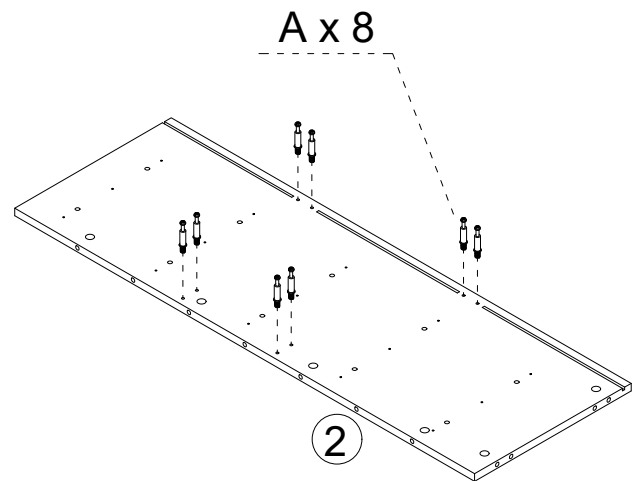
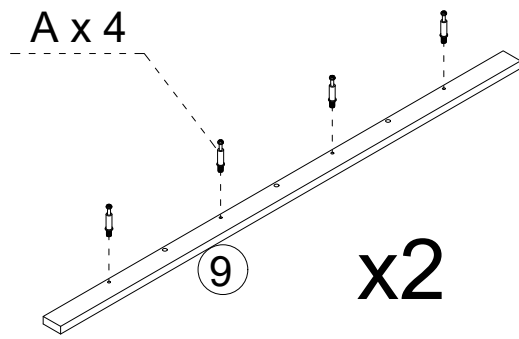
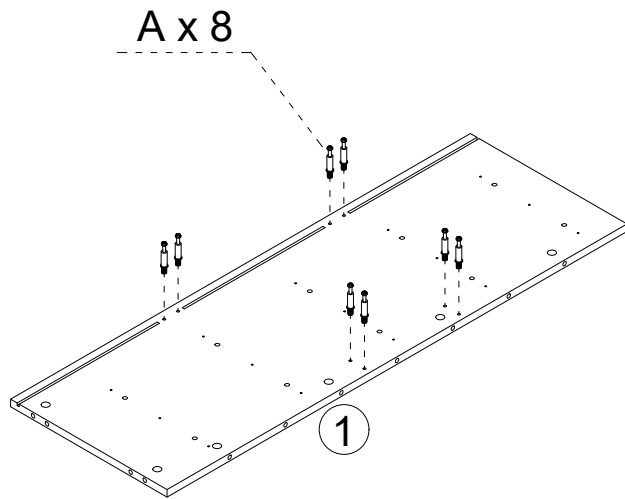

Step 2

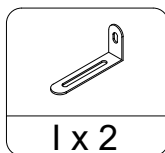
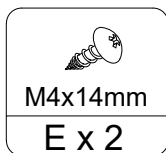
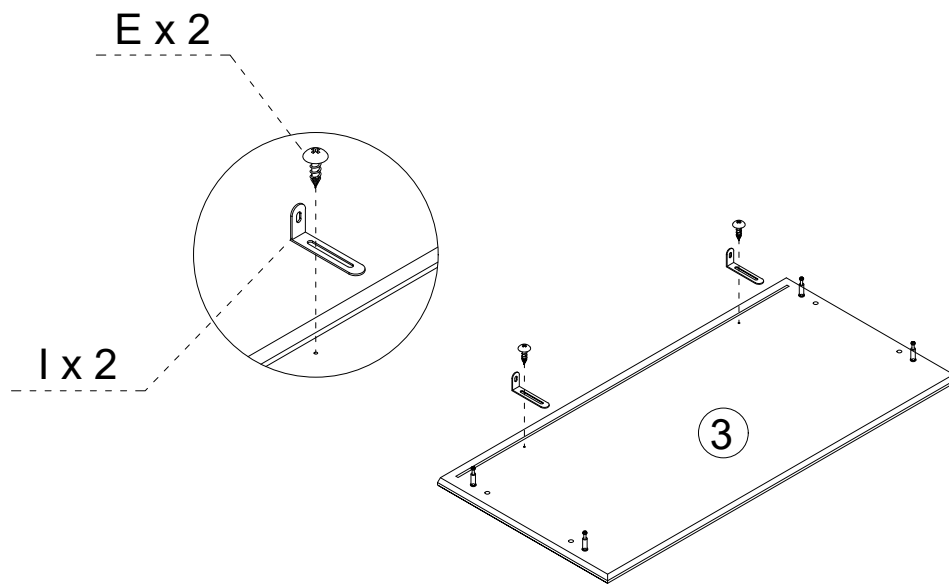

Step 3

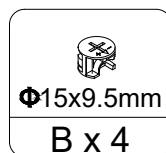
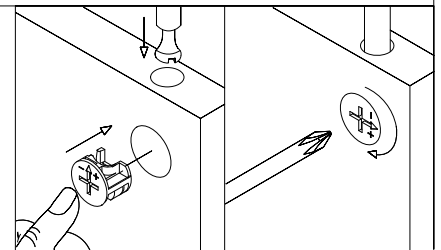
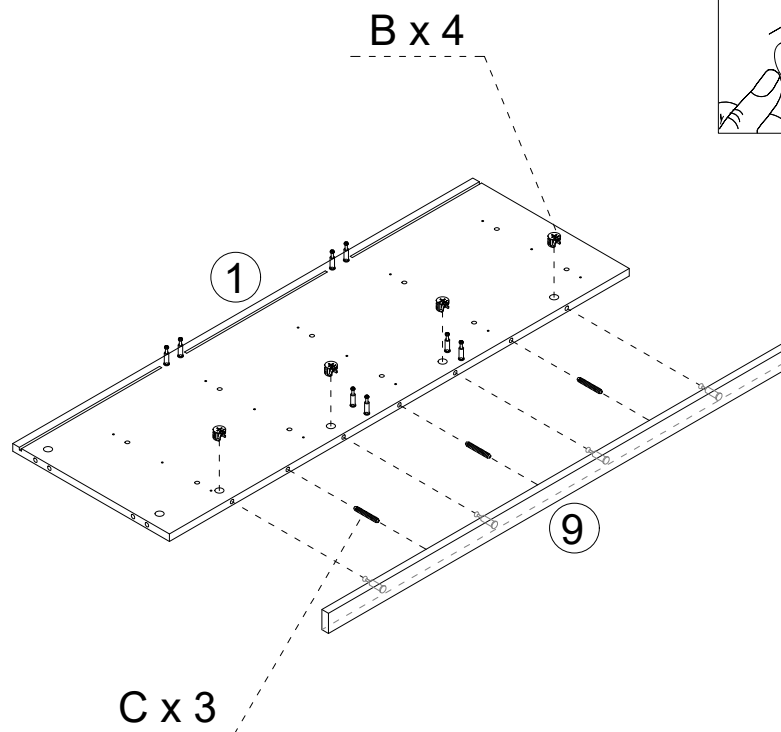

Step 4

**Slides Must Be Separated Before Assembly.
After Separated, Set Aside Until Needed for Assembly.**

Las diapositivas deben separarse antes del montaje.
Después de la separación, déjelo a un lado hasta que sea necesario.

Les glissières doivent être séparées avant l'assemblage.
Après la séparation, mettez de côté jusqu'au moment de l'assemblage.

**Pay attention when connecting !
The sliding module must be at the front end.**

STEP 1 : Extend Slide
Extender la diapositiva

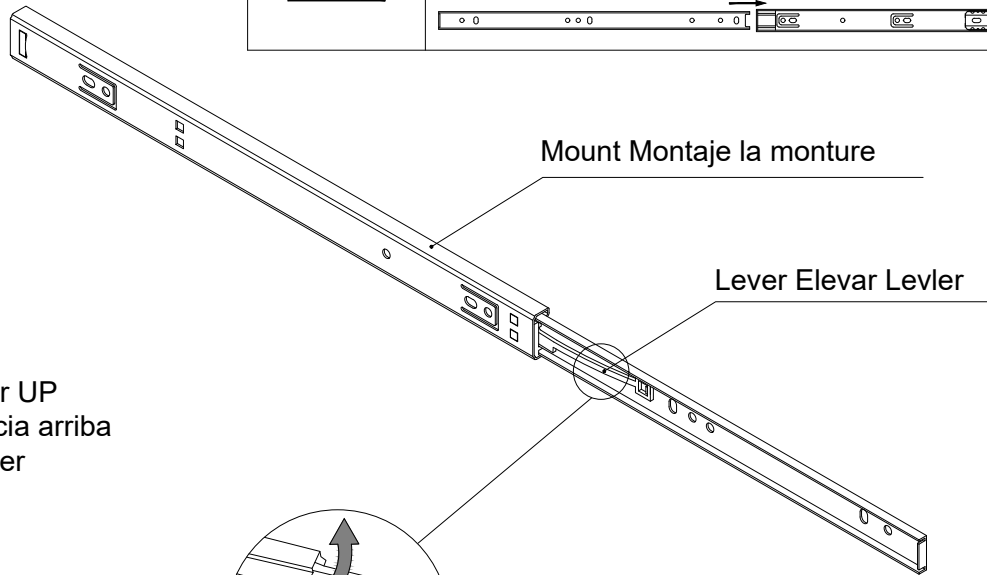
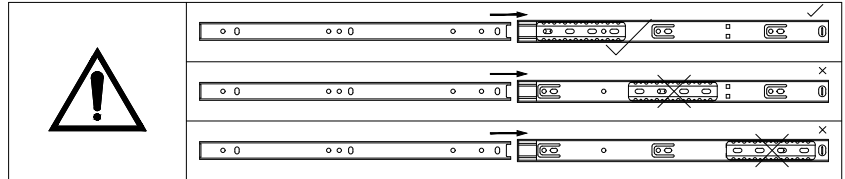

STEP 2: Push Lever UP
Empujar hacia arriba
Lever le levier

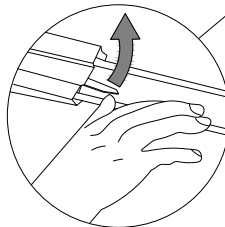

**Push lever for the left of drawer ,
press the lever for the right of drawer.**

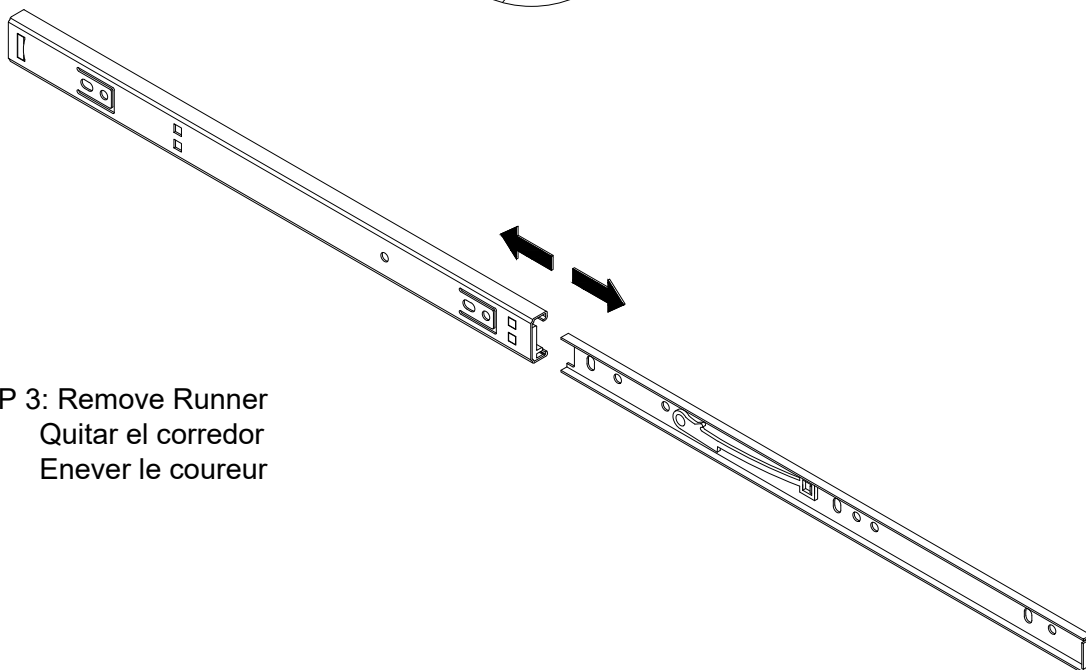

STEP 3: Remove Runner
Quitar el corredor
Enlever le coureur

Step 5

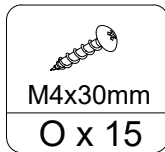
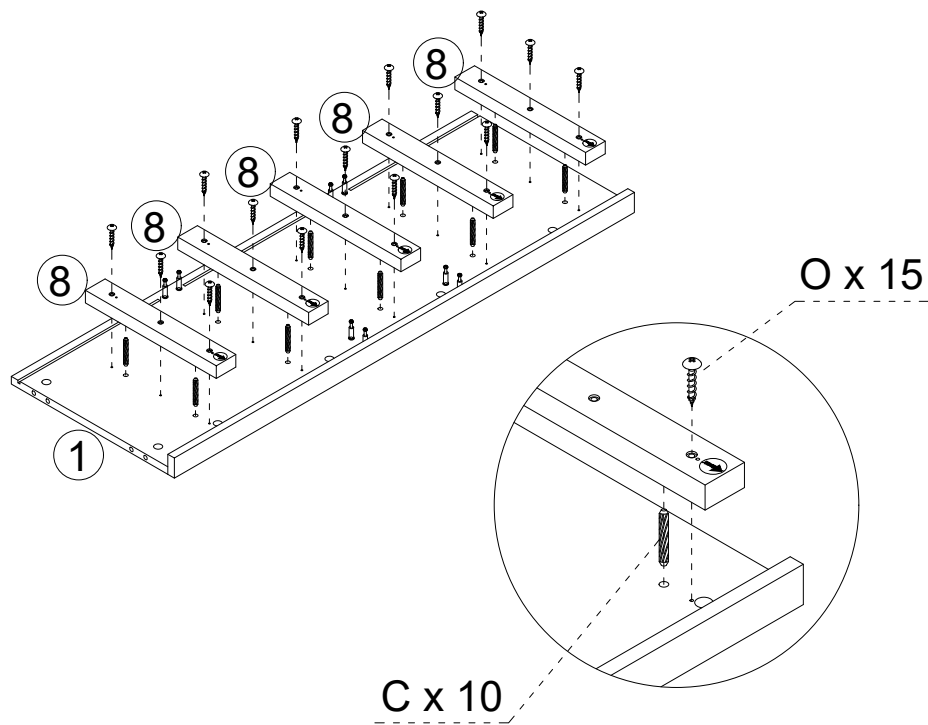

Step 6

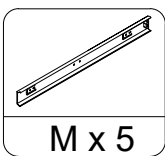
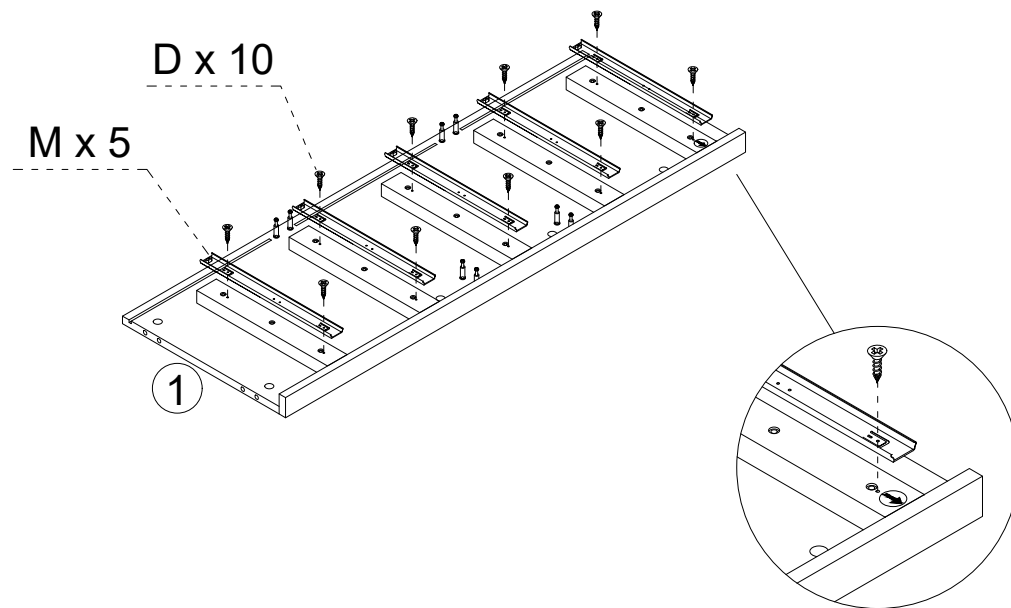

Step 7

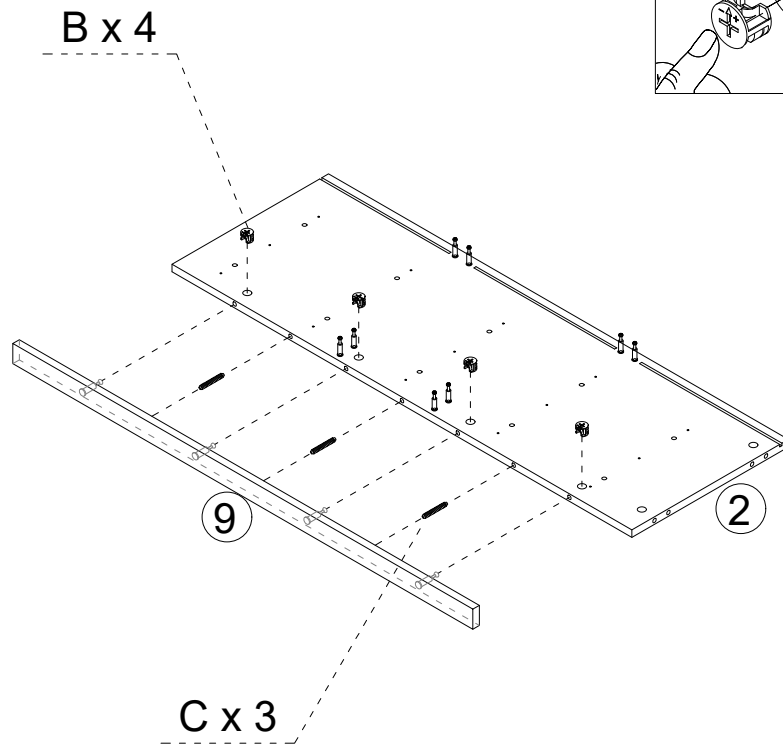



 $\Phi 15 \times 9.5 \text{mm}$
B x 4

 $\Phi 6 \times 30 \text{mm}$
C x 3

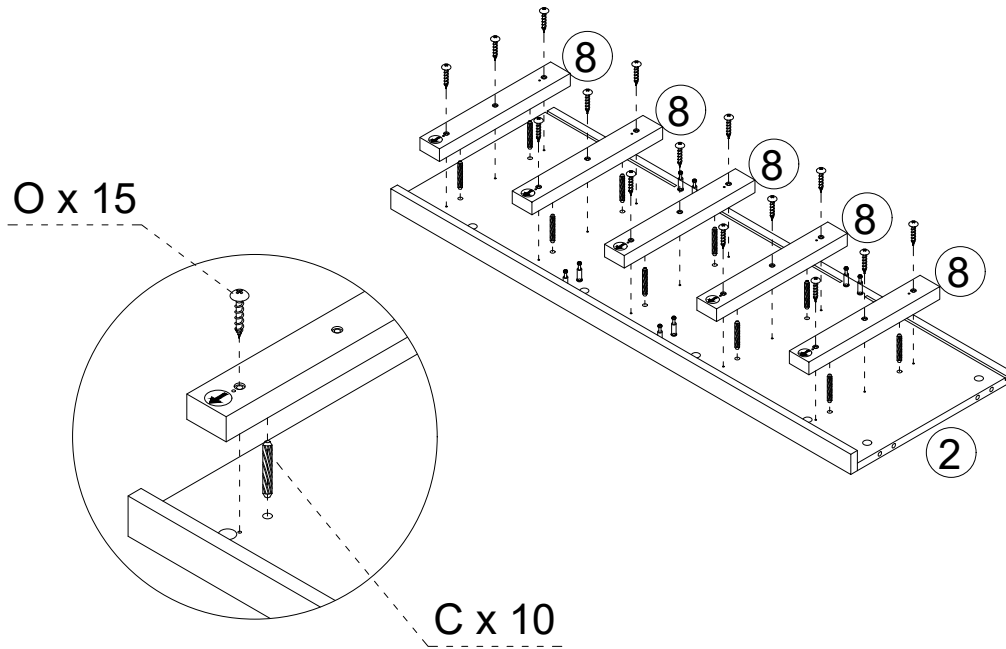
Step 8





 $\Phi 6 \times 30 \text{mm}$
C x 10

M4 x 30mm
O x 15

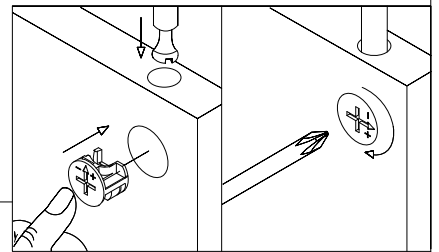
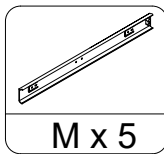
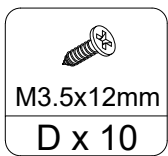
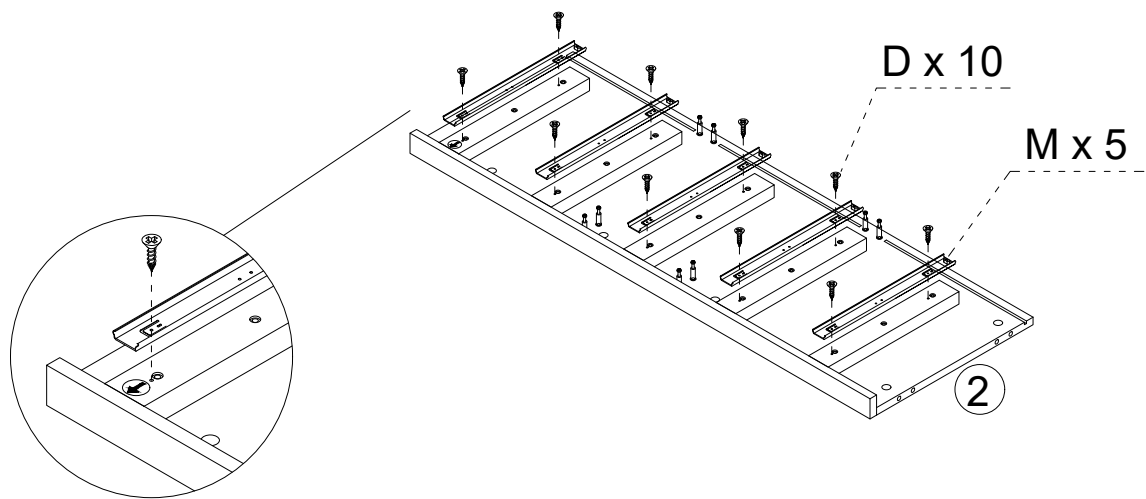
Step 9

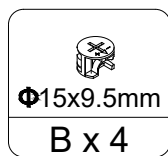
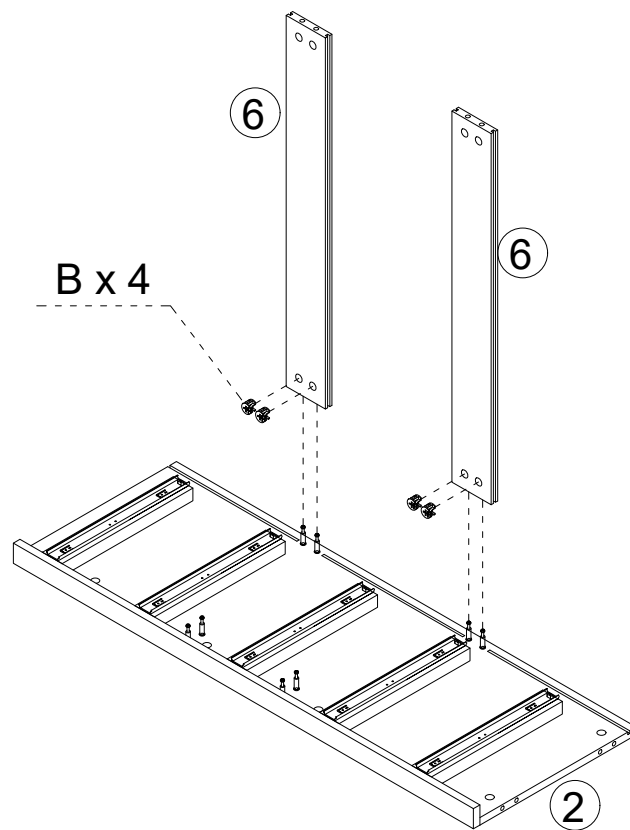

Step 10



Step 11

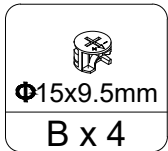
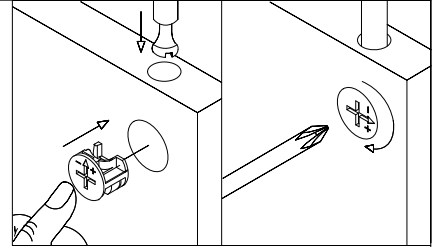
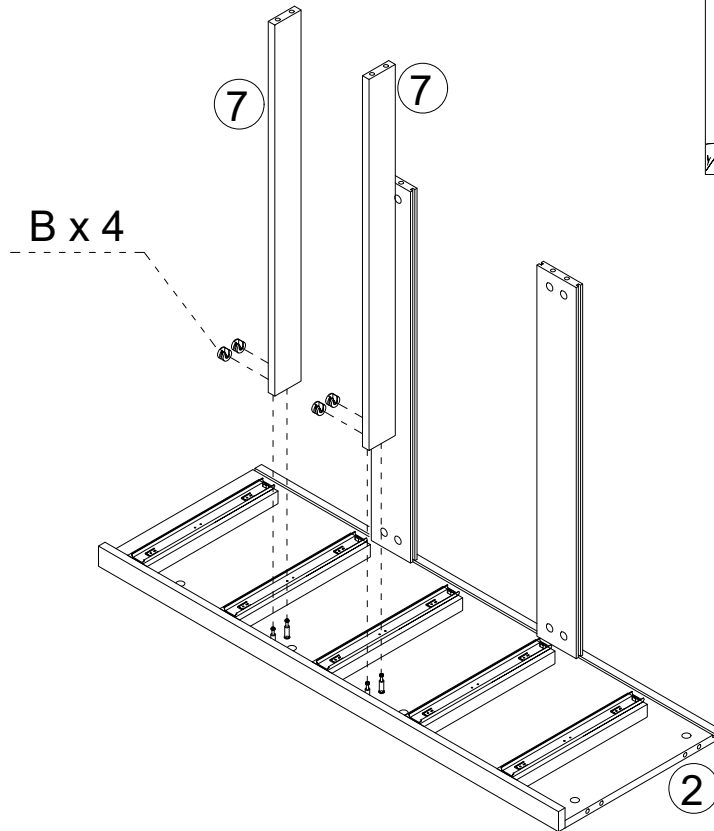

Step 12

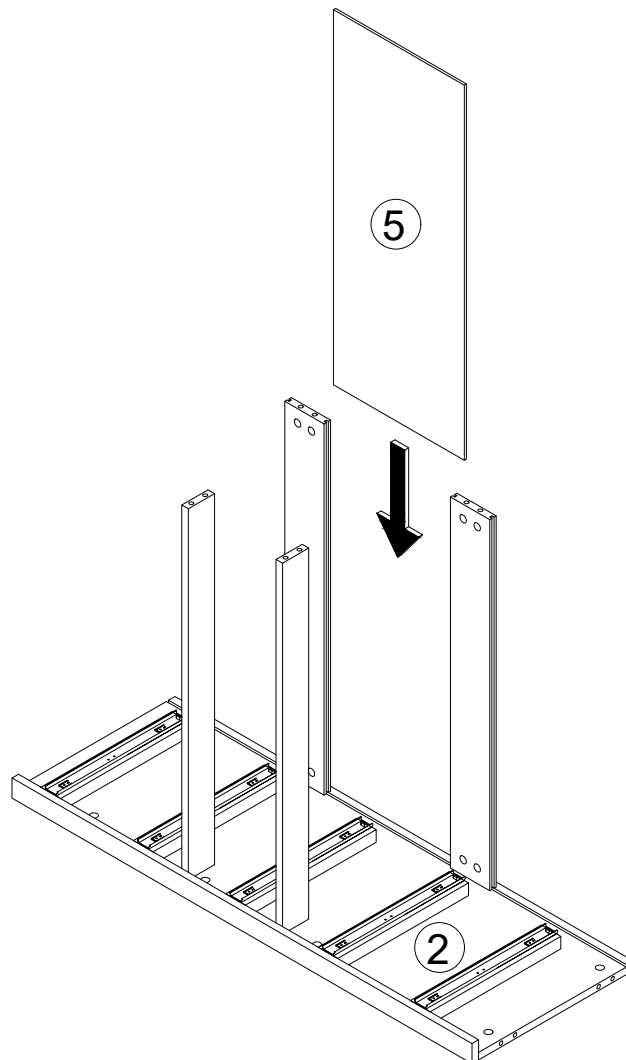

Step 13

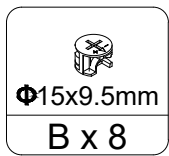
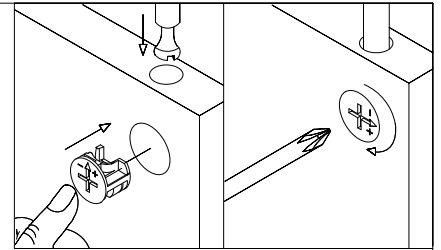
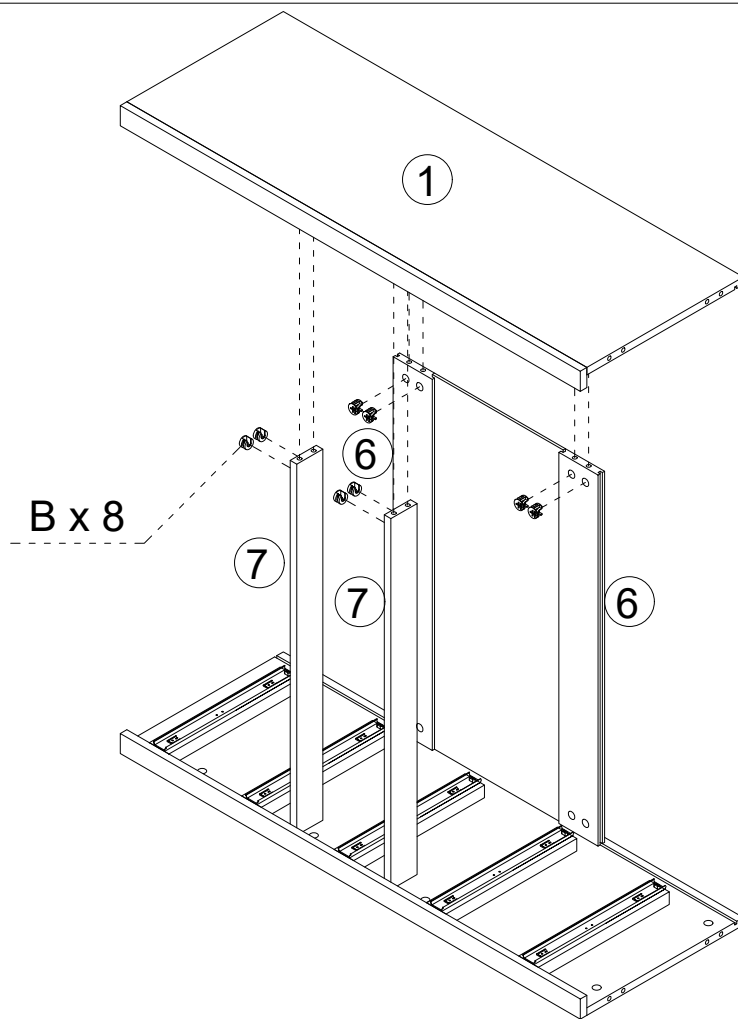

Step 14

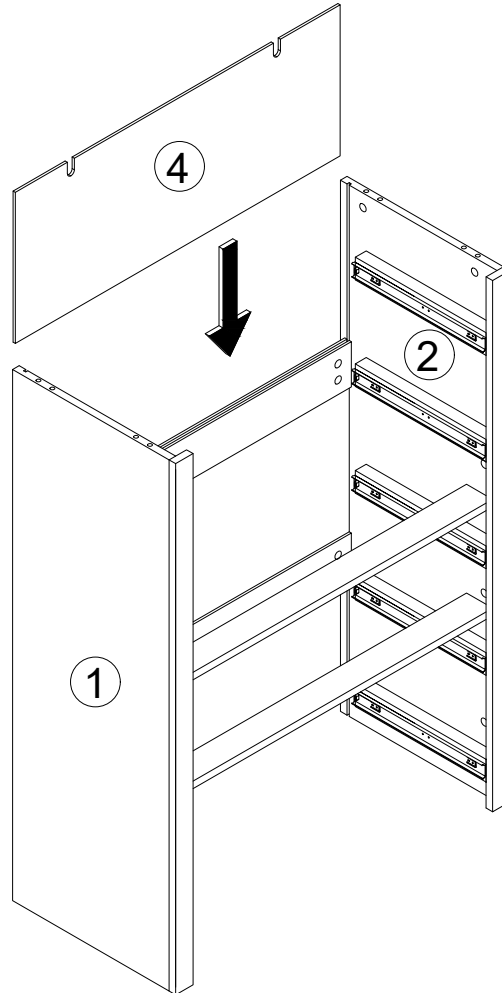

Step 15

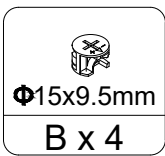
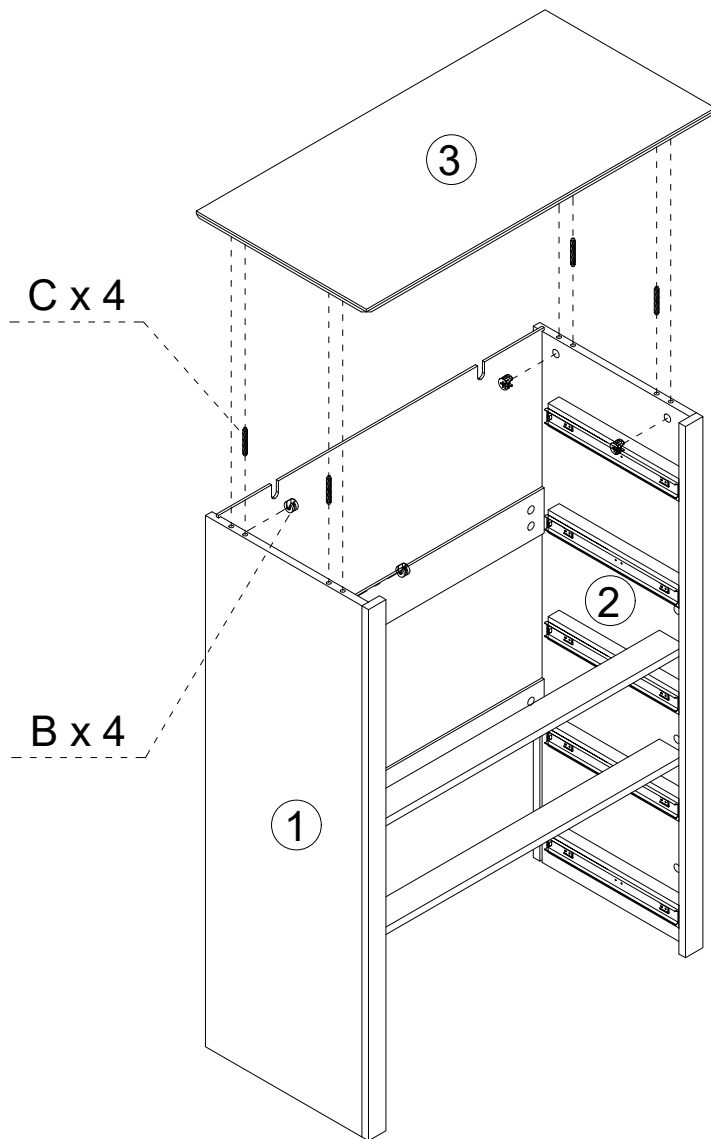
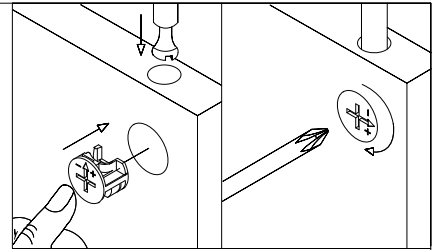

Step 16

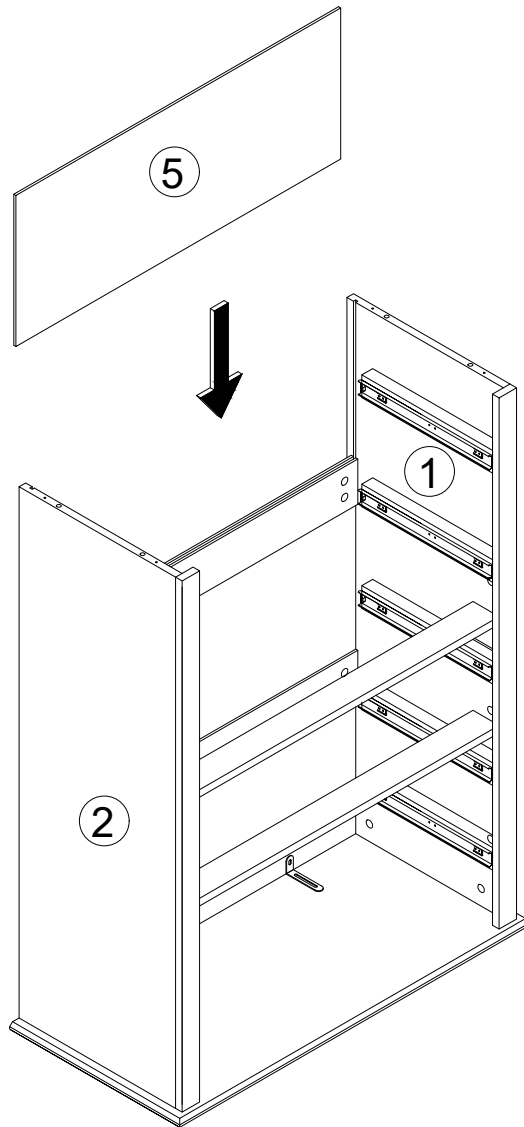

Step 17

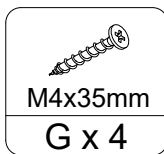
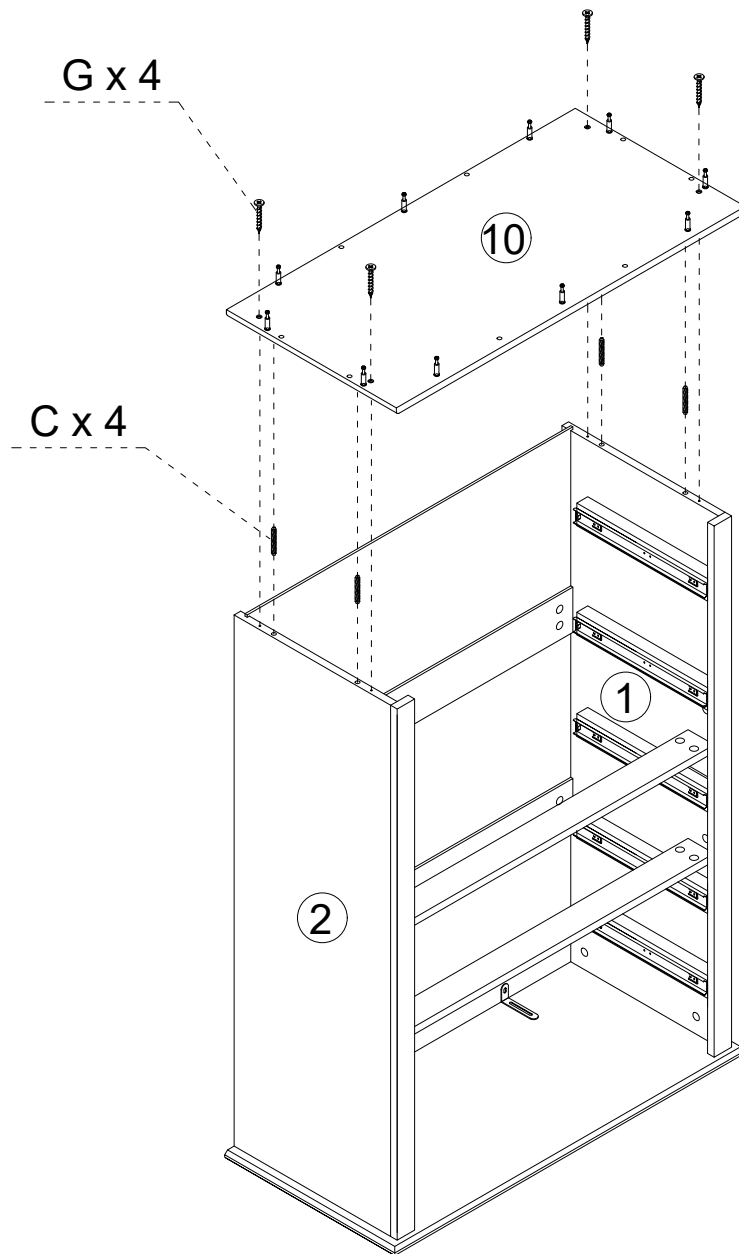

Step 18

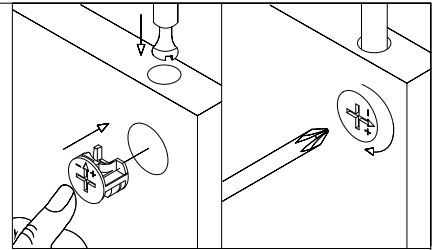
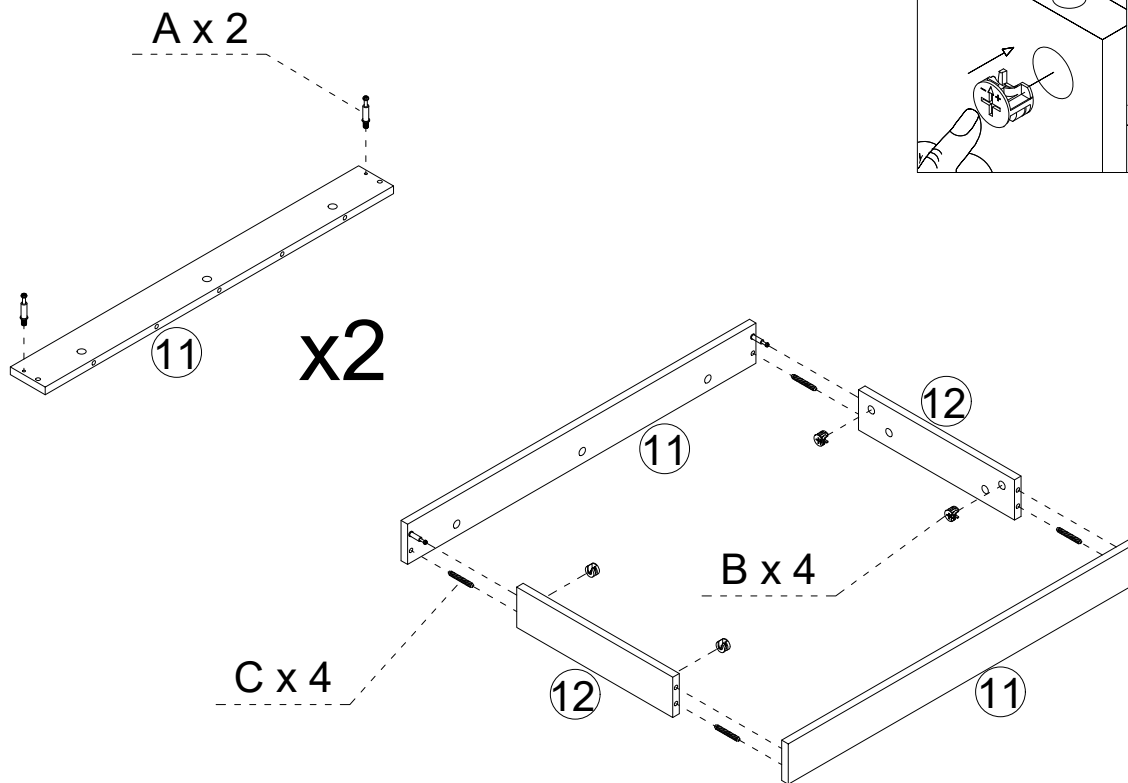

Step 19

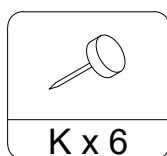
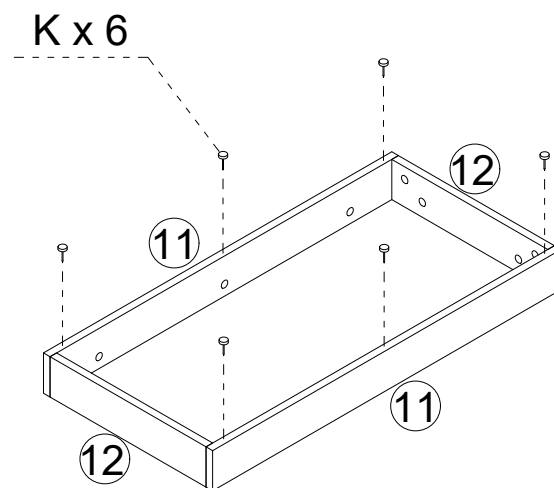

Step 20

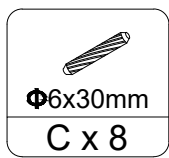
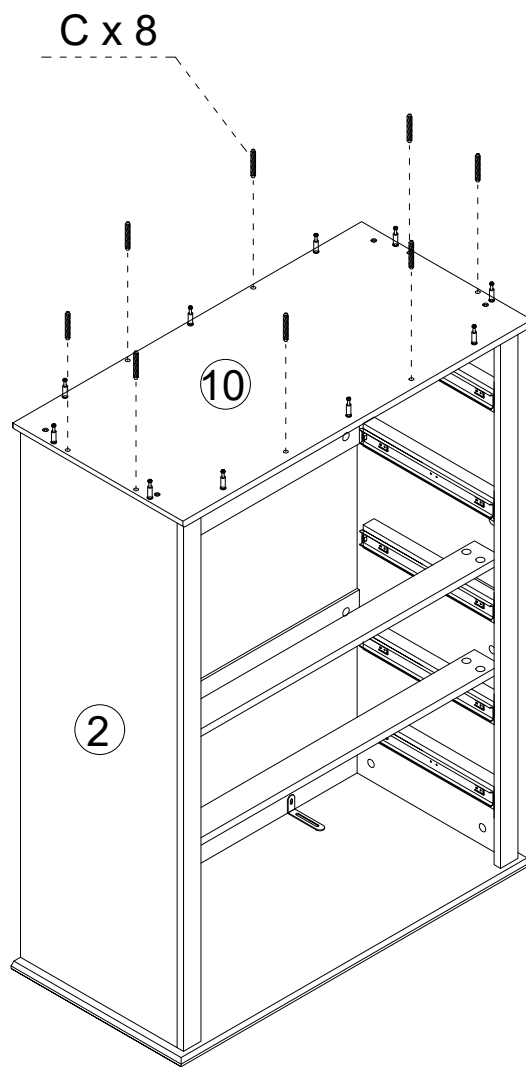

Step 21

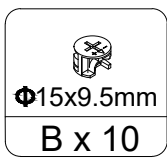
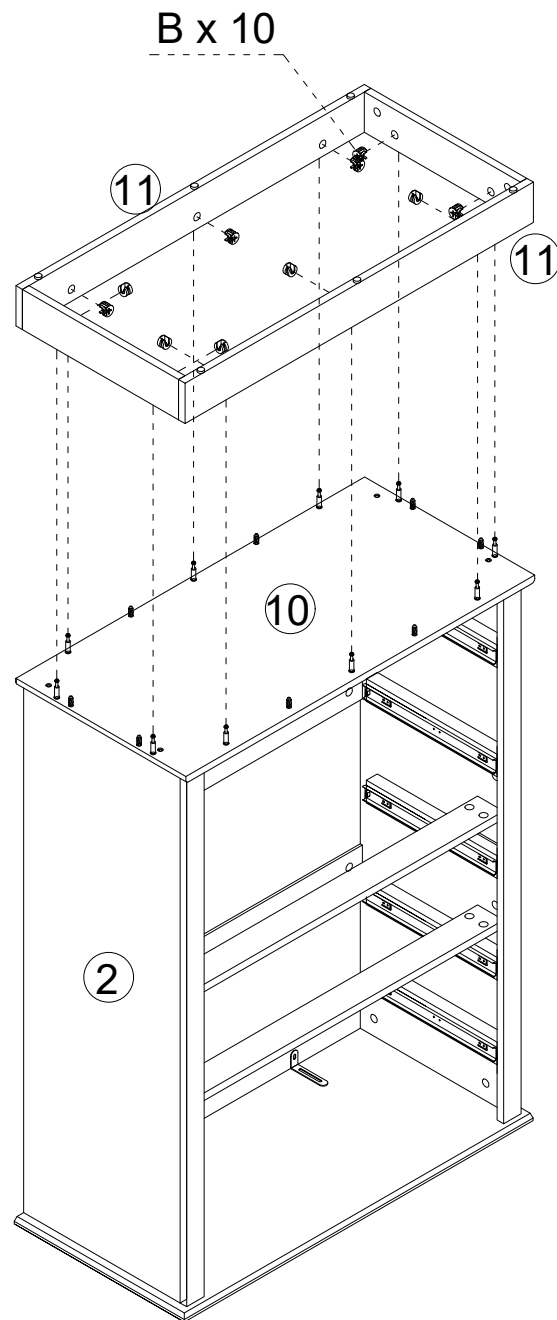
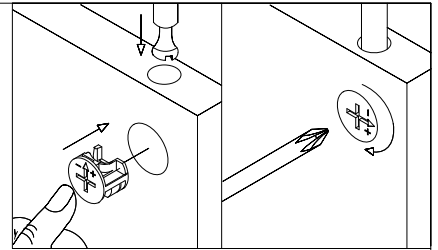

Step 22

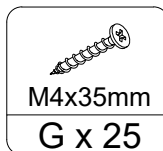
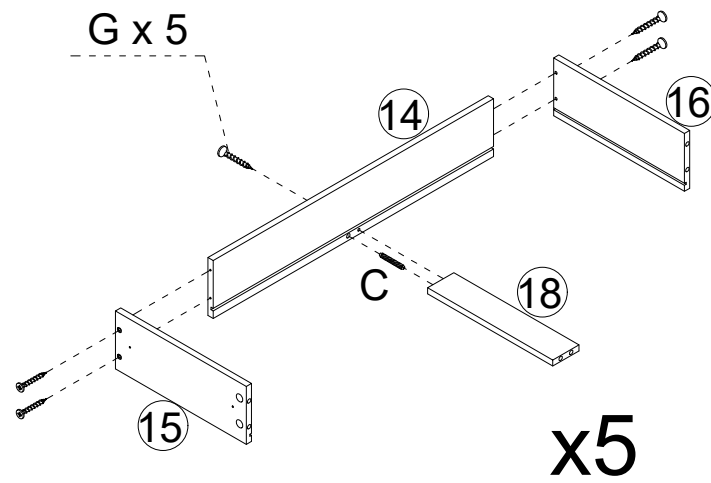

Step 23

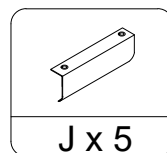
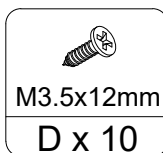
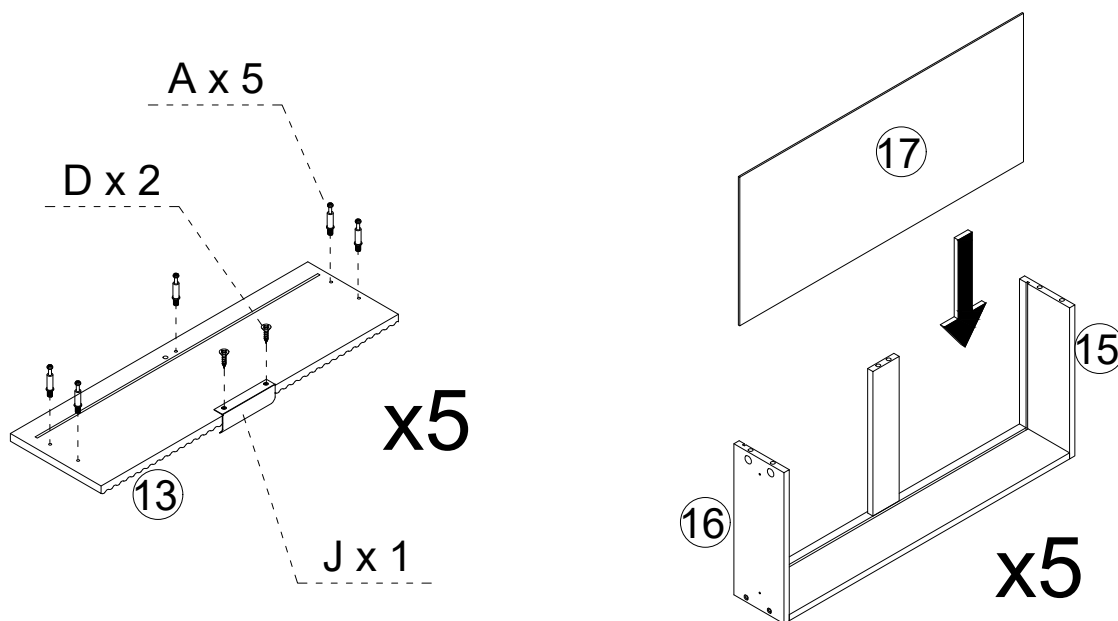

Step 24

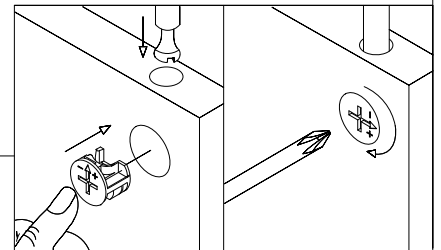
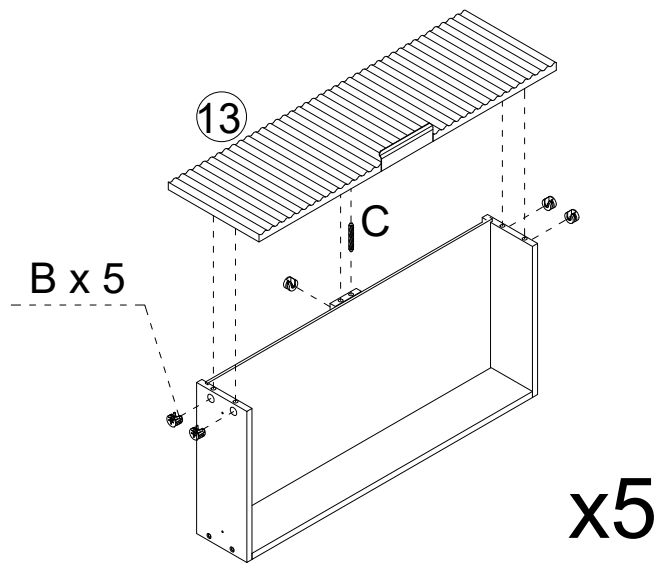

Step 25

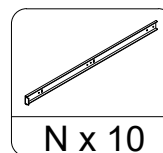
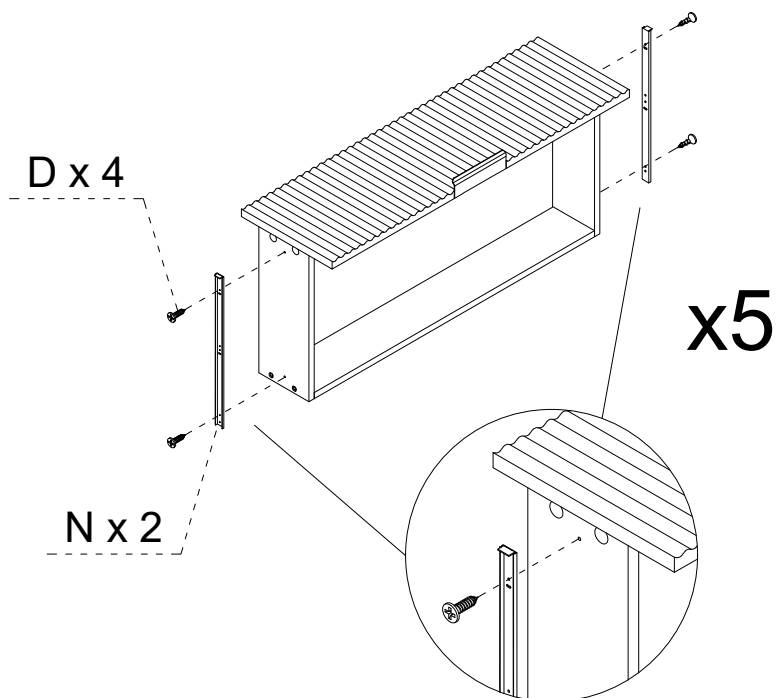

Step 26

Before proceeding to step 27, use a spirit level to evenly adjust the gaps around the drawer !

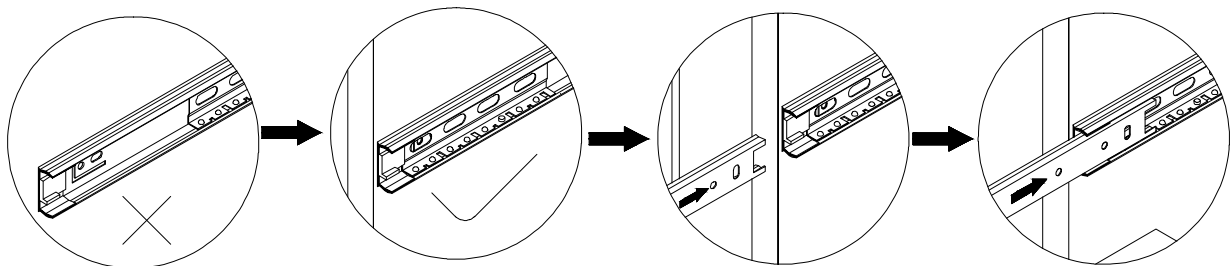
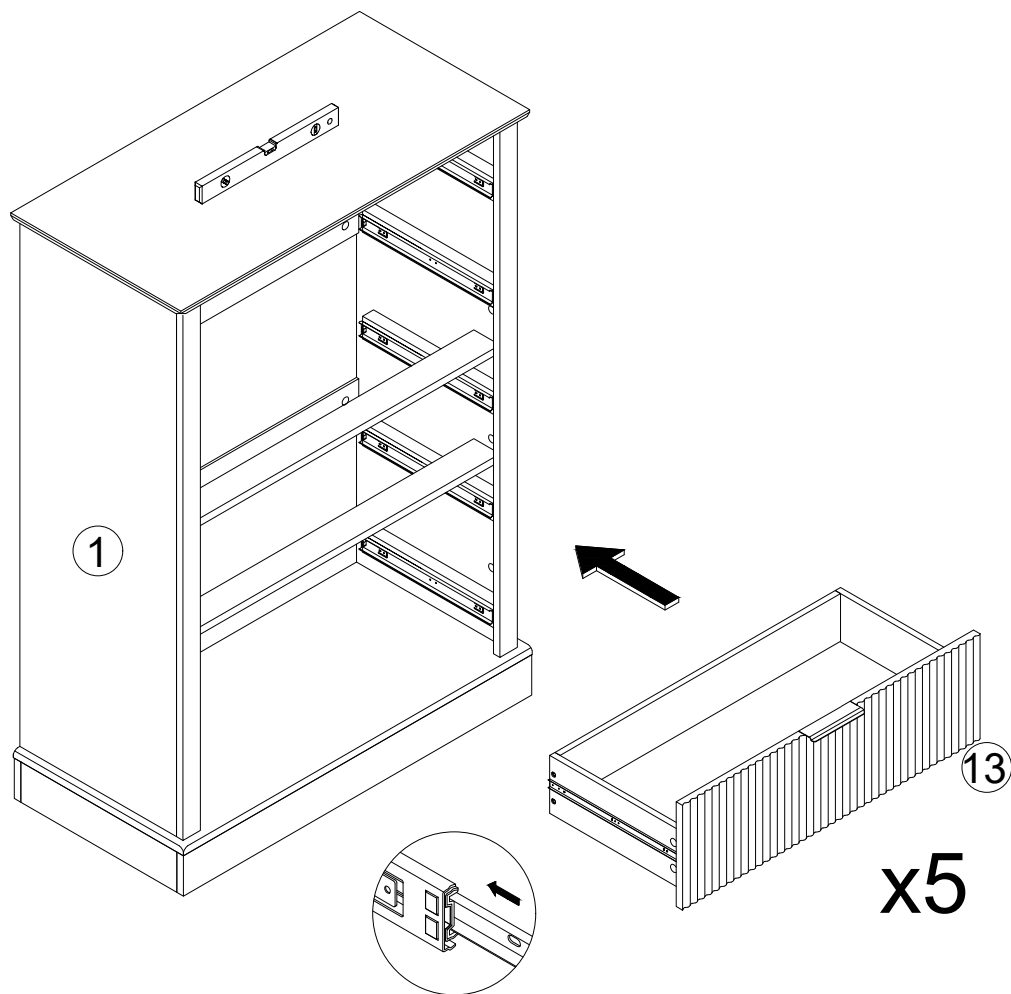

Step 27

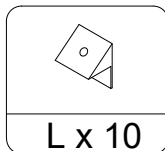
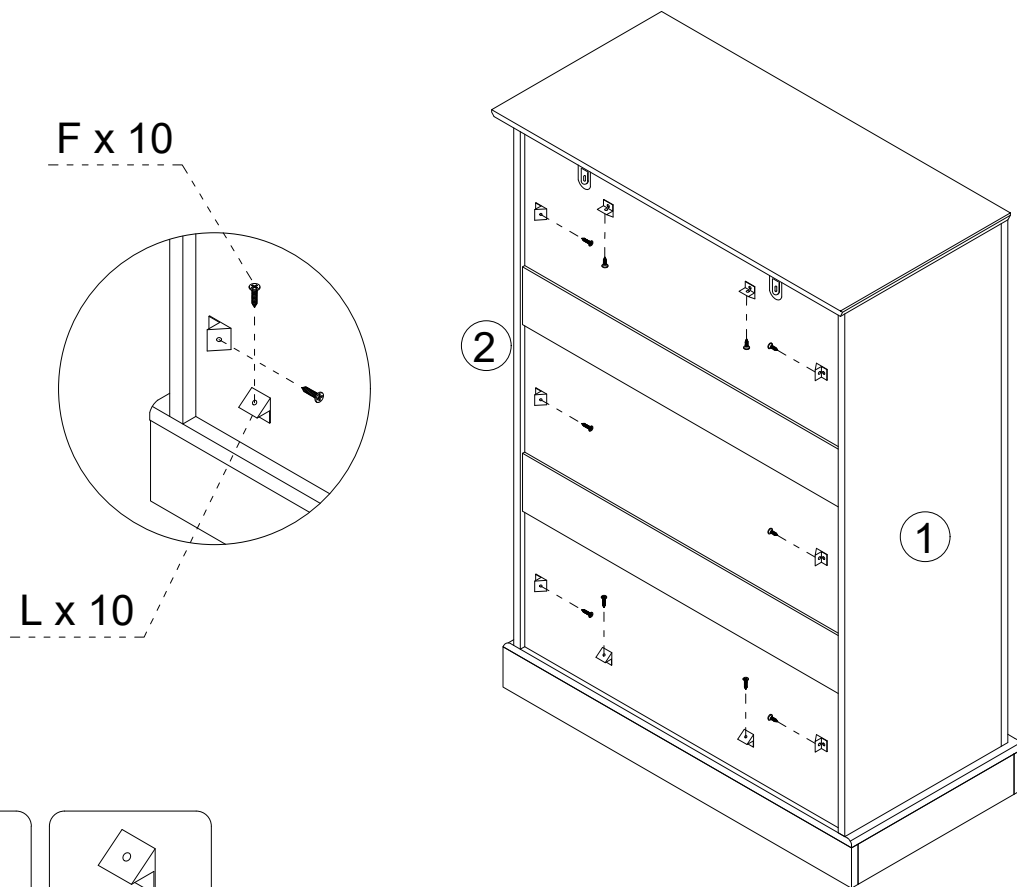

Step 28

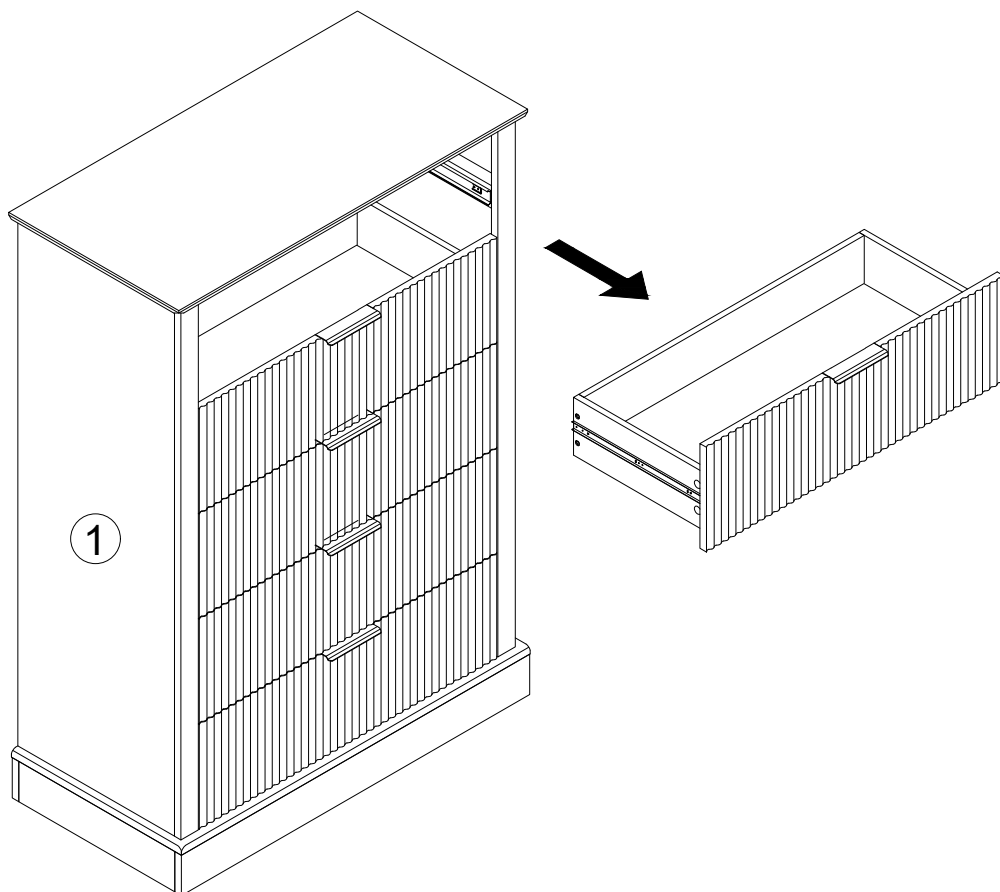

Step 29

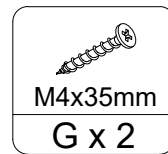
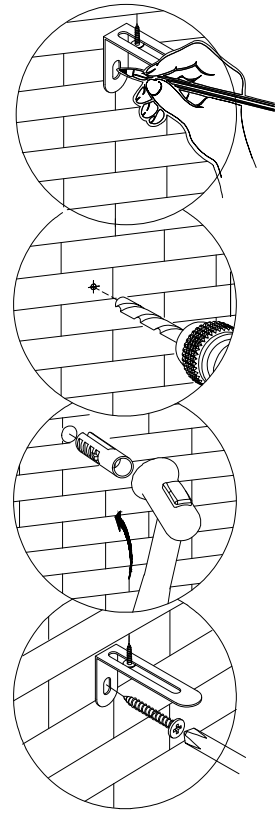
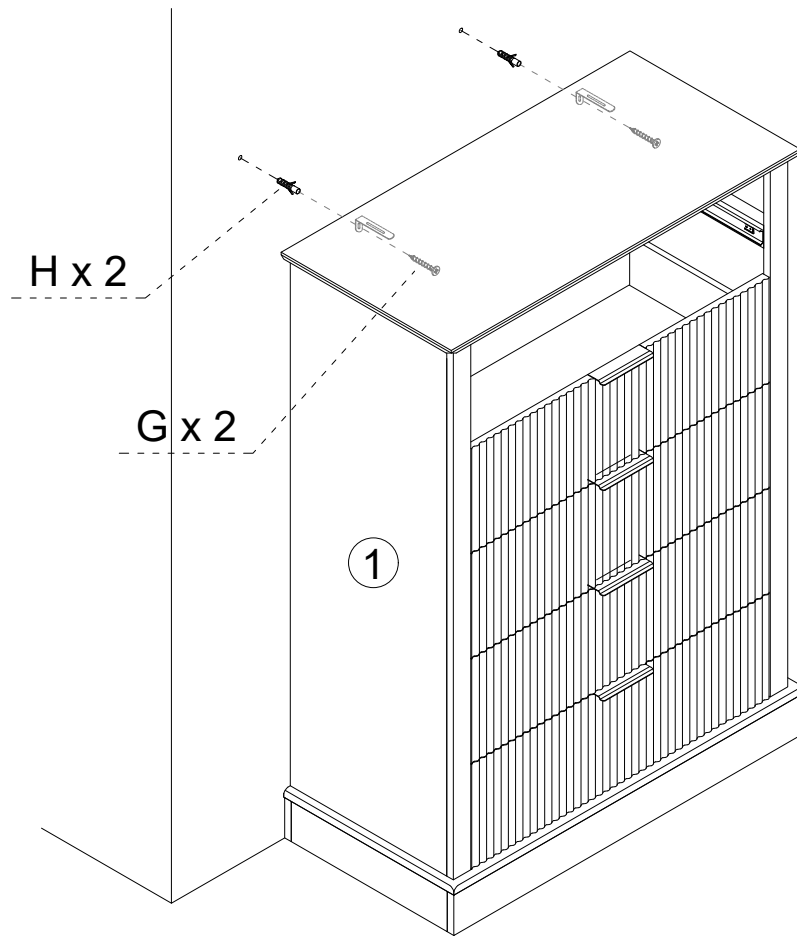

Step 30

