

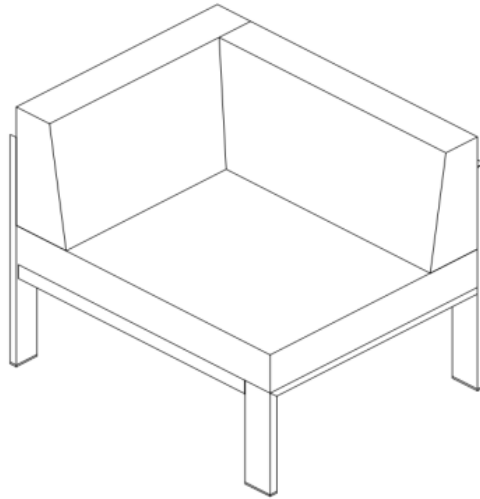





# Assembly Instructions

**Caution : You must read this before you proceed**



## Sofa Corner

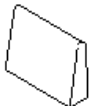

### Parts List

Label	Picture	Description	QTY
A		Side Panel	1
B		Back Support Bar	1
C		Seat Panel (Labeled with 'face' and 'bottom')	1
D		Leg Support Bar	1
E		Seat Cushion	1
F		Back Cushion	2

# Hardware

Label	Picture	Description	QTY
①		Bolt (M6*20MM)	11
②		Allen Key	1

# Assembly Preparation

Before Beginning Assembly:

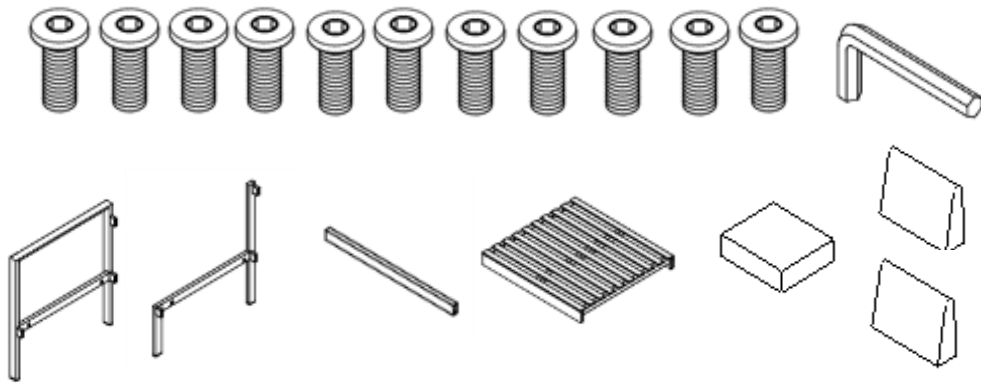

- Read instructions, cover to cover-



- Have 2 adults on hand for assembly-



- Do not assemble on flooring or carpet-



- Assemble on a clean non-marring surface (packing foam)-



- Save all packaging until finished-

## Assembly Steps

### Overview

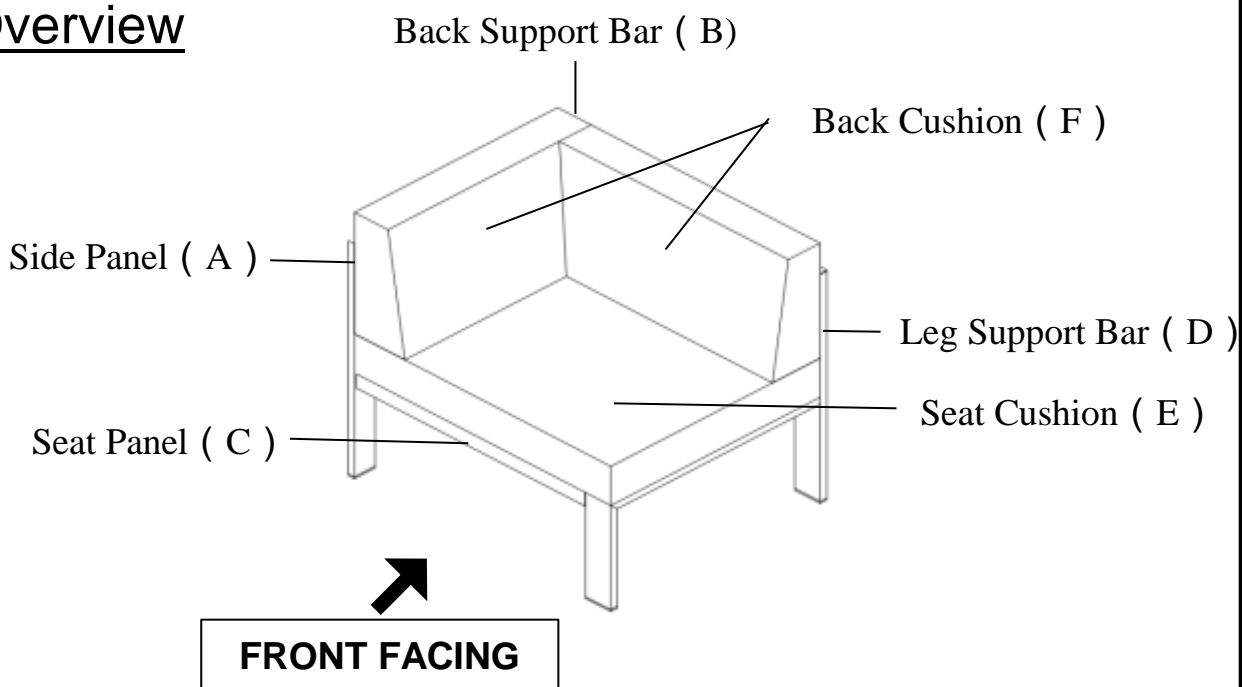

This Sofa Corner has multiple parts and may require up to 30 minutes to assemble. To give you an overview of the Sofa parts, the above picture is to help you put the various parts into perspective. Please read through the instructions below to familiarise yourself with the parts and steps before assembly.

### Step 1

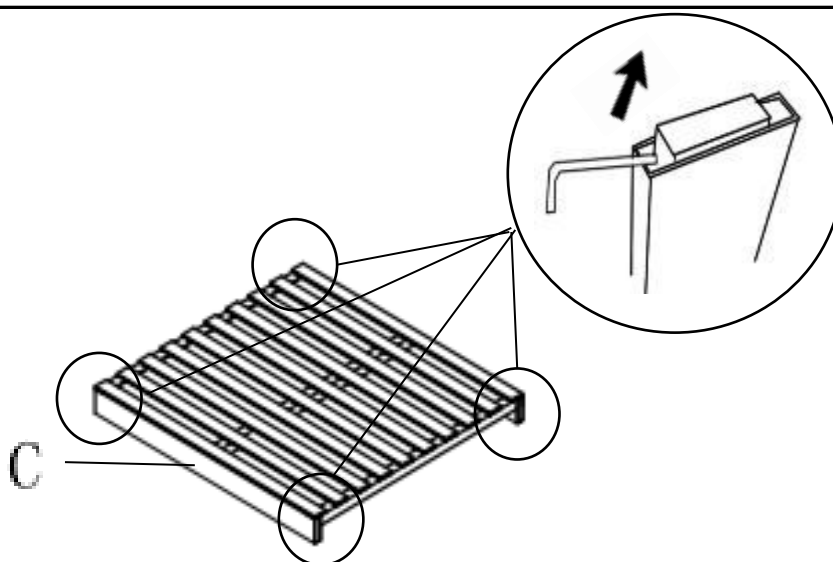

Open the carton and place all the parts onto a clean, non-marring surface.  
Remove the plastic plugs( prevent the alum tube was scratched) in the four ends of the Seat Board(C) using Allen Key(②) as shown above.

## Step 2

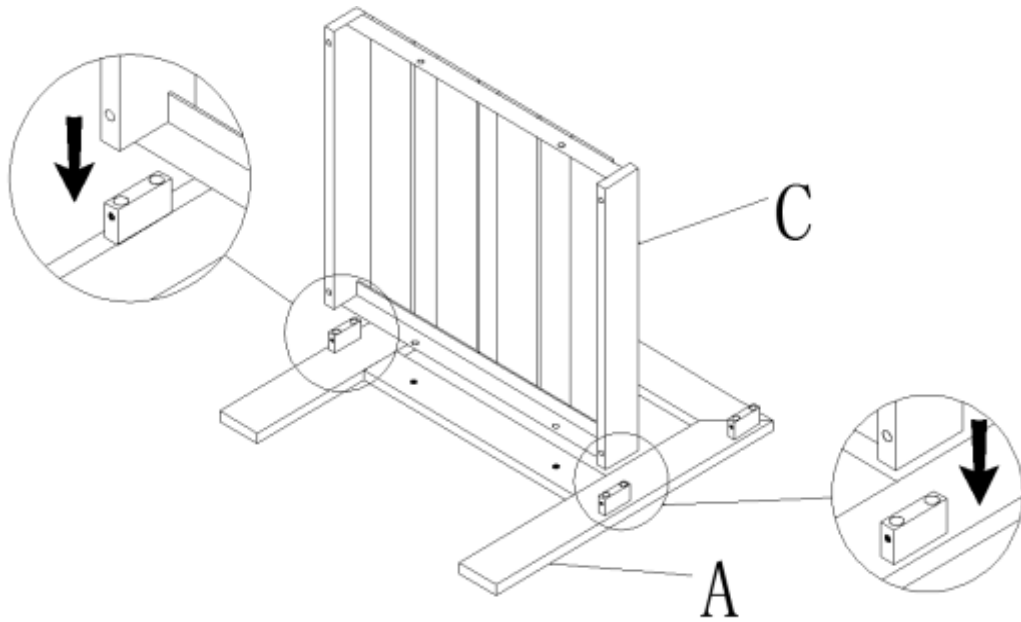

Place the Side Panel(A) with its inside facing up.  
Insert the Seat Panel(C) into the Side Panel(A).

## Step 3

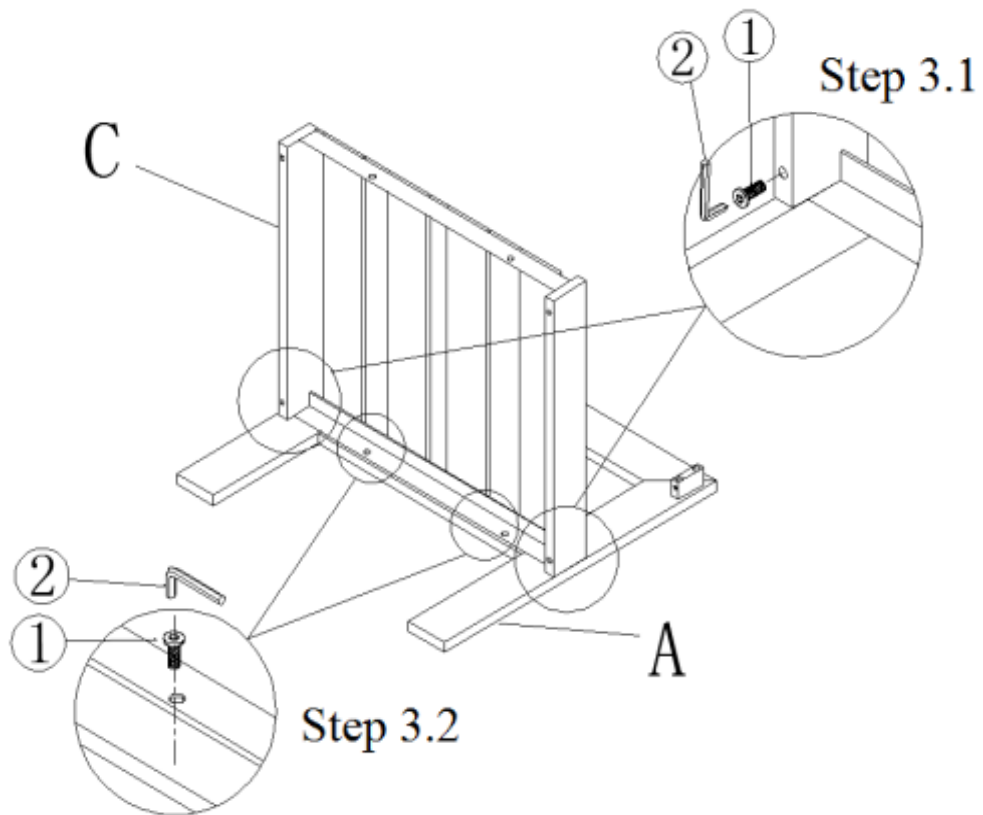

**3.1)** Attach the Seat Panel(C) to Side Panel(A) using Bolts(①) with Allen Key(②) as shown above.

**3.2)** Attach the Seat Panel(C) to Side Panel(A) using Bolts(①) with Allen Key(②) as shown above.

## Step 4

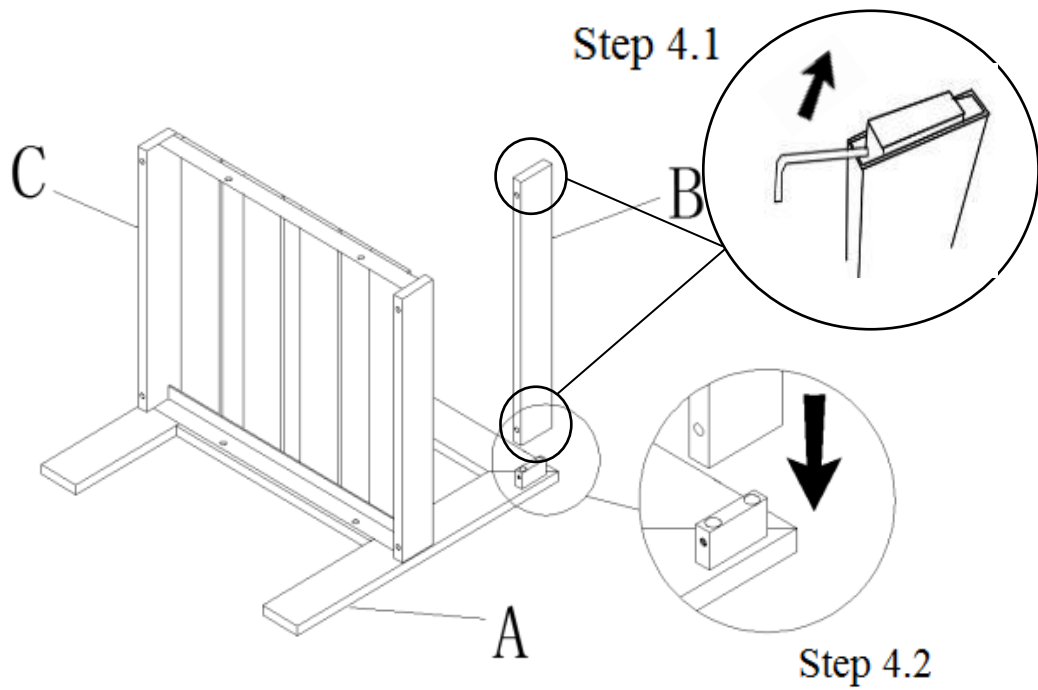

**4.1)** Remove the plastic plugs( prevent the alum tube was scratched) in the both ends of Back Support Bar (B) using Allen Key(②) as shown above.

**4.2)** Insert the Back Support Bar(B) into the Side Panel(A).

## Step 5

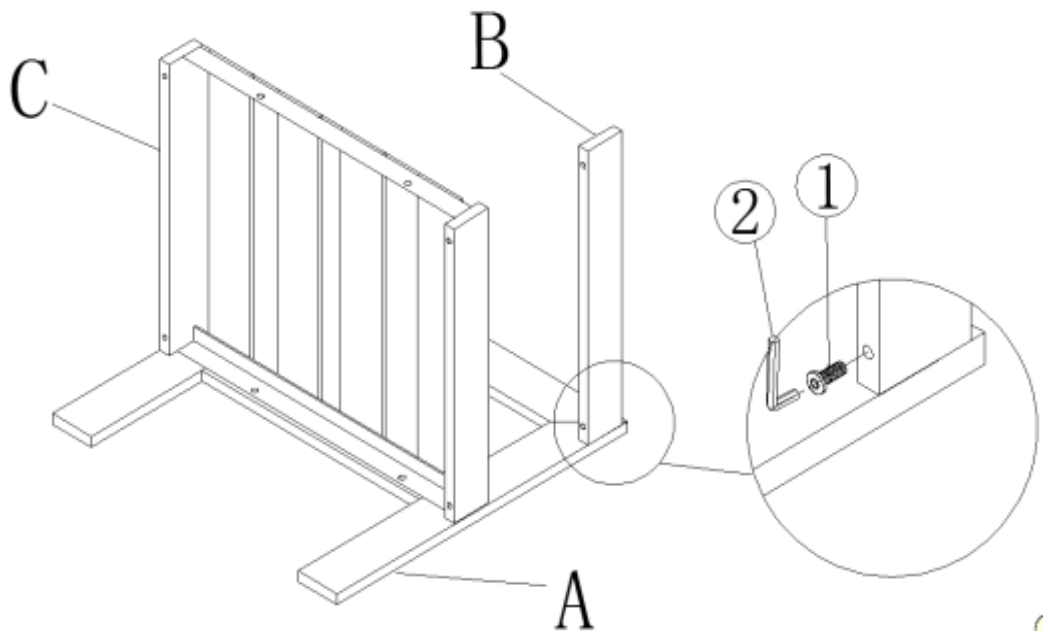

Attach the Back Support Bar(B) to the Side Panel(A) using Bolt(①) with Allen Key(②).  
**Do not fully tighten Bolts.**

## Step 6

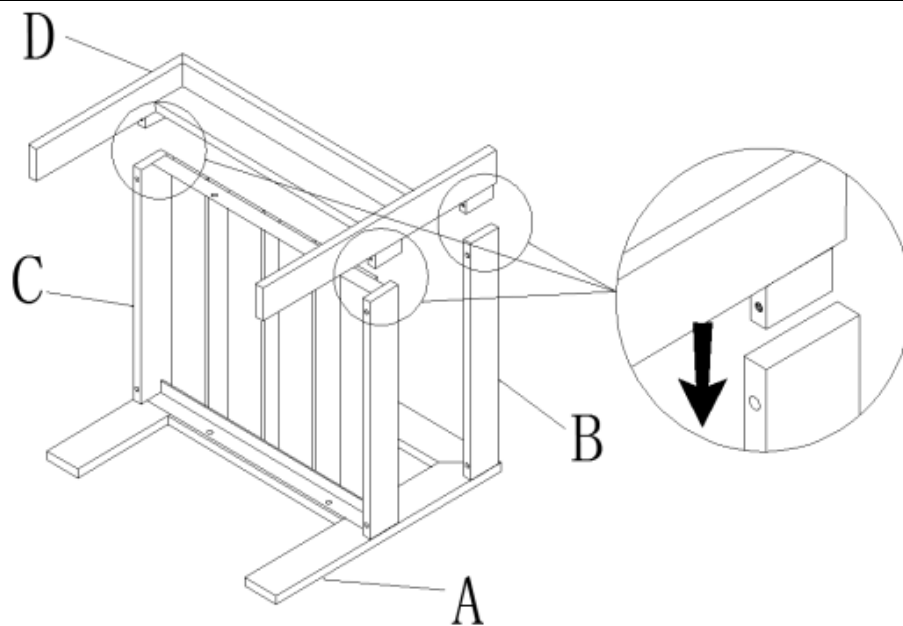

Insert the Leg Support Bar(D) into the Back Support Bar(B) and Seat Panel(C) as shown above.

## Step 7

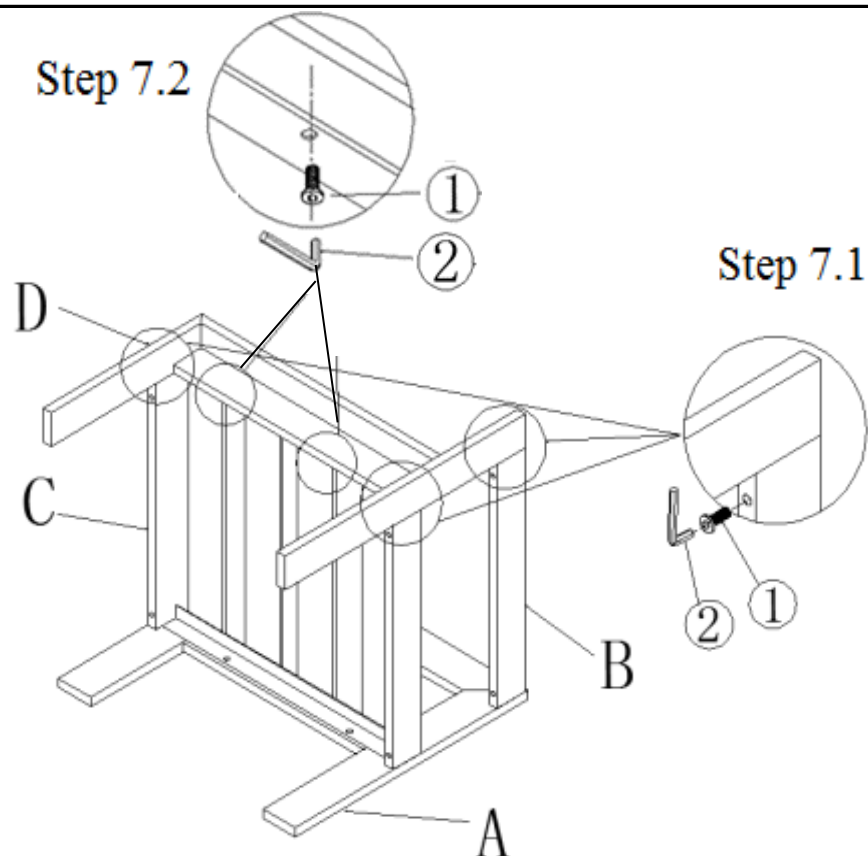

**7.1)** Attach the Leg Support Bar(D) to Back Support Bar(B) and Seat Panel(C) using Bolts(①) with Allen Key(②) as shown above.

**7.2)** Attach the Leg Support Bar(D) to Back Support Bar(B) using Bolts(①) with Allen Key(②) as shown above.

**Do not fully tighten Bolts.**

## Step 8



Stand the Sofa Corner up.

Place the Sofa Corner on a **LEVEL SURFACE**.

Inspect it and make sure all parts are adequately connected.

Gently and carefully, sit onto the Sofa Corner.

This will help to align all the parts at all joints.

Then get off the Sofa Corner, and in a sequential manner, proceed to tighten all Bolts.

**When tightening the Bolts, tighten sequentially.**

**DO NOT tighten any Bolt fully and then move on to the next one.**

**This may cause the frame to warp.**

**If there are still wobbles, loosen the Bolts and execute the same process.**

**If the Sofa is not stable it could lead to damage to the product.**

**Note: This step is done best with the assistance of a second adult.**

## Step 9

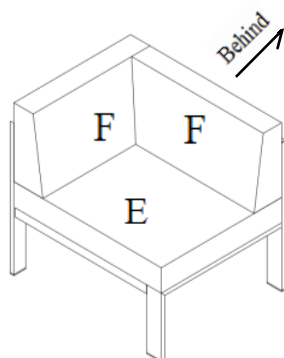
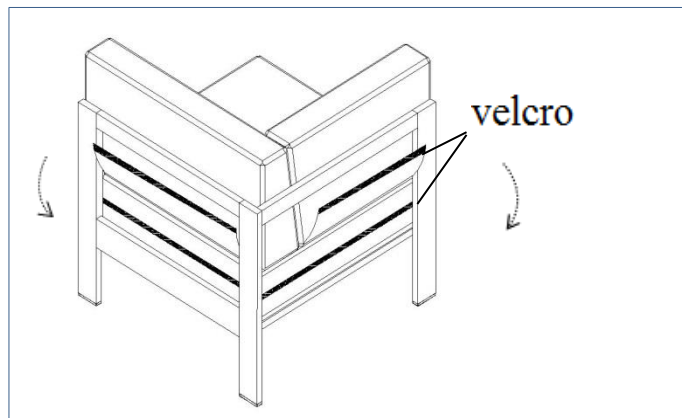

Put Seat Cushion(E) and Back Cushions(F) on the Sofa and stick the velcro from back cushion to seat cushion as shown above

Your Sofa Corner is ready for use.