

ASSEMBLY INSTRUCTIONS

Read this instruction carefully. See hardware and furniture part list for guidance. Be sure all parts are complete, before you assemble. Place all wooden furniture parts on a clean and flat soft surface to prevent from being scratched. Follow the figure to start assembling.

CAUTIONS : 1. Do not FULLY - TIGHTEN the nut or nut bolt until all nut or bolt is ready assembled.
2. Do not OVER - TIGHTEN the nut or bolt to avoid causing damages to the thread.
3. Keep all hardware parts out of reach of children.

NOTE : THE LIST AND QUANTITY SHOWN ARE FOR 1 UNIT ASSEMBLY.

Tool needed : Screwdriver (not provider).

PART LIST		
ITEM	DESCRIPTION	QTY
A	CHAIR BACK	1 PC
B	CUSHION SEAT FRAME	1 PC
C	ARM (L)	1 PC
D	ARM (R)	1 PC

HARDWARE LIST		
ITEM	DESCRIPTION	QTY
1	JCBC Bolt M6 x 40mm	6pcs
2	JCBC Bolt M6 x 70mm	2pcs
3	JCBC Bolt M6 x 80mm	2pcs
4	Wood SCREW M4 x 38mm	2pcs
5	M6 SPRING WASHER	10pcs
6	M6 FLAT WASHER	10pcs
7	M4 ALLEN KEY (BALL SHAPE)	1pc

STEP 1

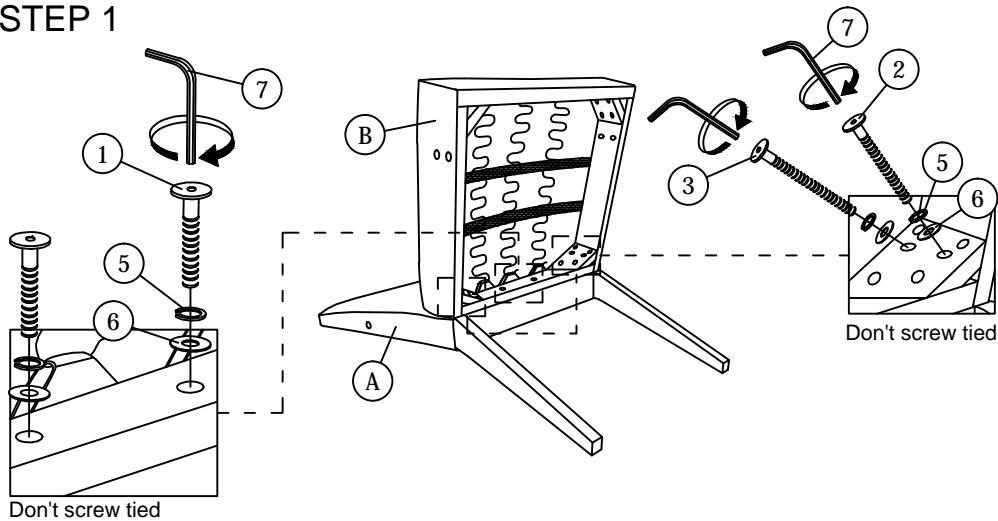

STEP 2

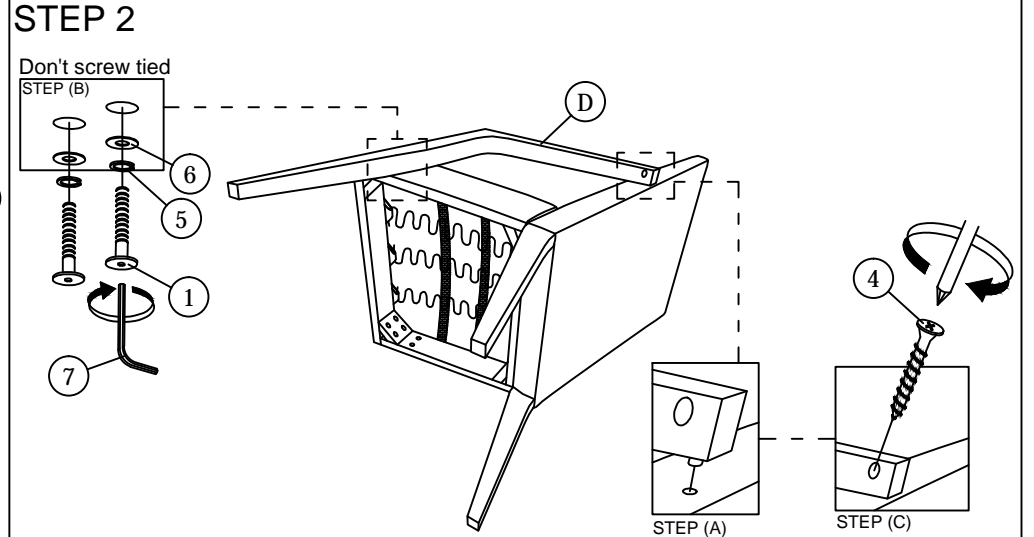

STEP 3

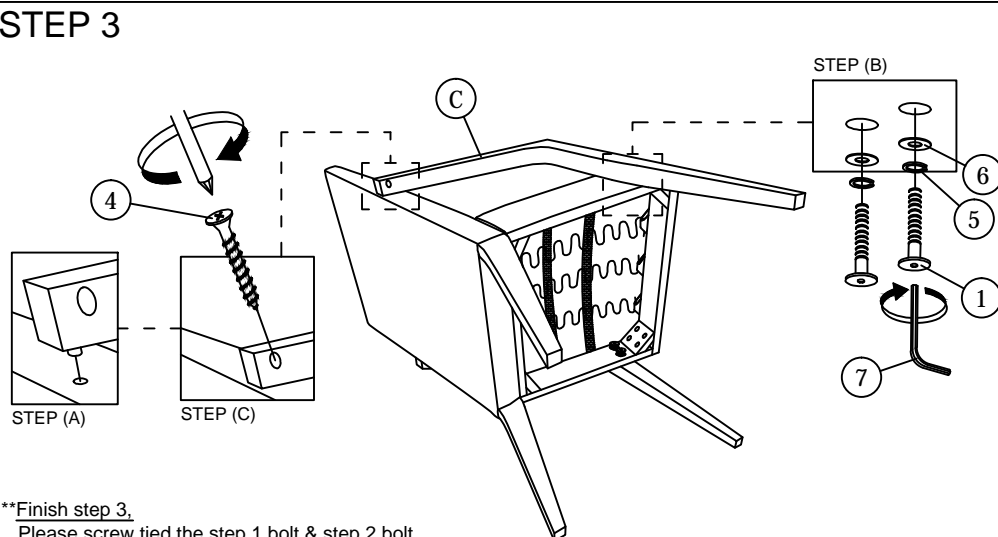

STEP 4

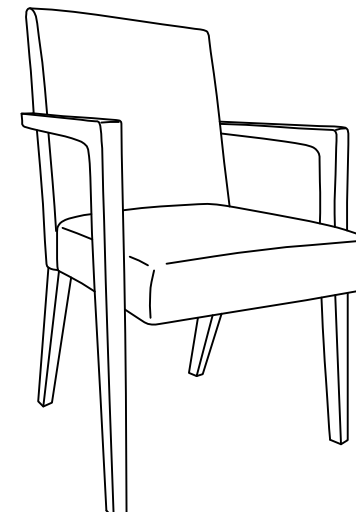

****Finish step 3.**
Please screw tied the step 1 bolt & step 2 bolt.

ASSEMBLY INSTRUCTIONS

Read this instruction carefully, remove all wrapping material, staples and straps from the carton. See hardware and furniture part list. For guidance. Be sure you have all wooden furniture parts on a clean and soft surface to prevent from being scratched. Follow the figure to start assembling.

Caution:

1. Do not FULLY -TIGHTEN the nut or bolt until all nut or nut bolt is ready to assembled.
2. Do not OVER- TIGHTEN the nut or nut bolt to avoid causing damages to the thread.
3. Keep all hardware part out of reach of children.

PART LIST

No.	DESCRIPTION	QTY
A	TABLE TOP	1
B	TABLE LEG	4

HARDWARE LIST

No.	DESCRIPTION	QTY
1	FLAT WASHER 6/19"	8
2	SPRING WASHER 6/13"	8
3	JCBC SCREW M6 X 70MM	8
4	M4 ALLEN KEY	1

STEP 1

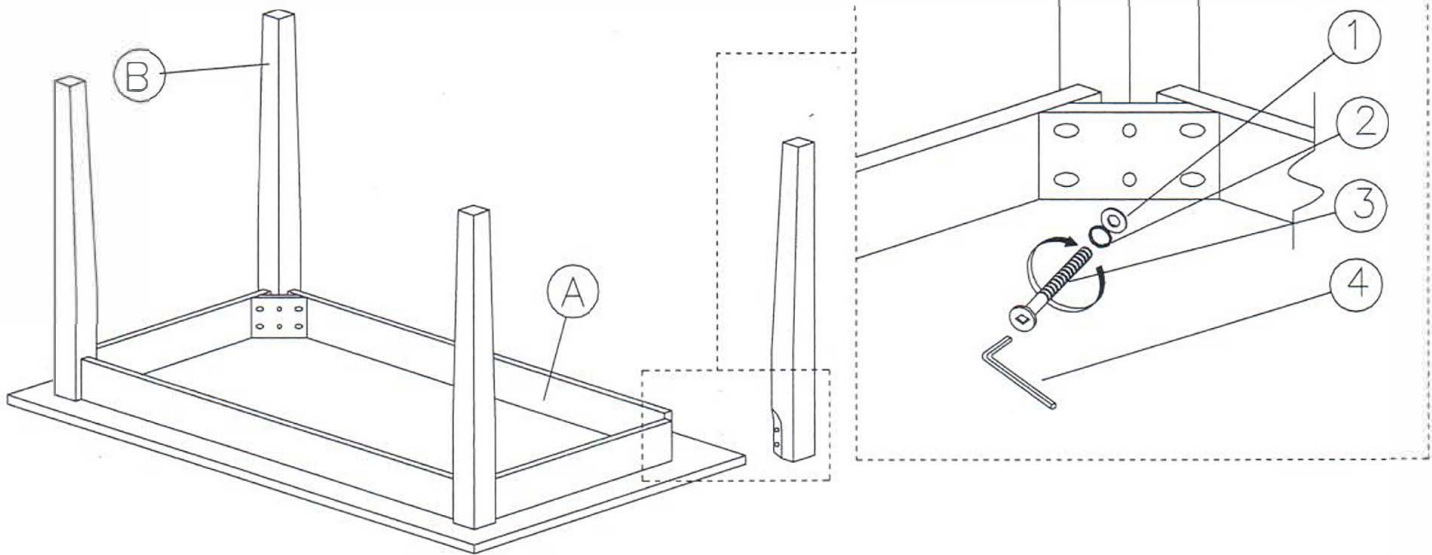

STEP 2

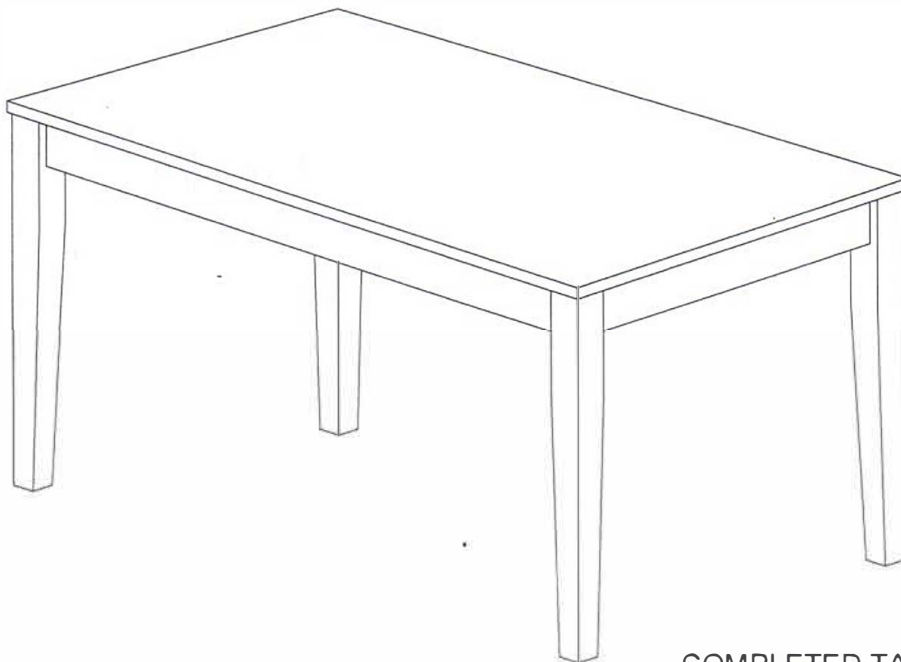

COMPLETED TABLE ASSEMBLY