

BAR STOOL

ASSEMBLY INSTRUCTION



ASSEMBLY INSTRUCTION

ASSEMBLY TIPS:

1. Remove hardware from box and sort by size.
2. Please check to see that all hardware and parts are present prior to start of assembly.
3. Please follow attached instructions in the same sequence as numbered to assure fast & easy assembly.



Warning!

1. Don't attempt to repair or modify parts that are broken or defective. Please contact the store immediately.
2. This product is for home use only and not intended for commercial establishments.

ASSEMBLY TIME PER UNIT: 10MINUTES

PARTS IDENTIFICATION



ASSEMBLY INSTRUCTION

ASSEMBLY TIPS:

1. Remove hardware from box and sort by size.
2. Please check to see that all hardware and parts are present prior to start of assembly.
3. Please follow attached instructions in the same sequence as numbered to assure fast & easy assembly.









Warning!

1. Don't attempt to repair or modify parts that are broken or defective. Please contact the store immediately.
2. This product is for home use only and not intended for commercial establishments.



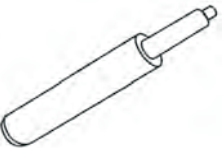

ASSEMBLY TIME PER UNIT: 10MINUTES

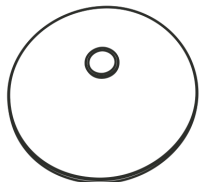
PARTS IDENTIFICATION

NOTE: QUANTITIES SHOWN ARE FOR ONE CHAIR

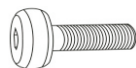
			
1PC	1PC	1PC	1PC
A-BACK	B-SEAT	C-BACK SUPPORT	D-FOOTREST
			
1PC	1PC	1PC	
E-GAS CYLINDER	F-DECORATIVE RING	G-CASTER	

Z HARDWARE IDENTIFICATION

NO	DESCRIPTION	FIGURE	Q`TY
1	BOLTS M6x20mm		4PCS
2	BOLTS M6x16mm		4PCS
3	BOLTS M6x20mm		3PCS
4	ALLEN WRENCH M6		1PC
5	ALLEN WRENCH M5		1PC

ASSEMBLY INSTRUCTION

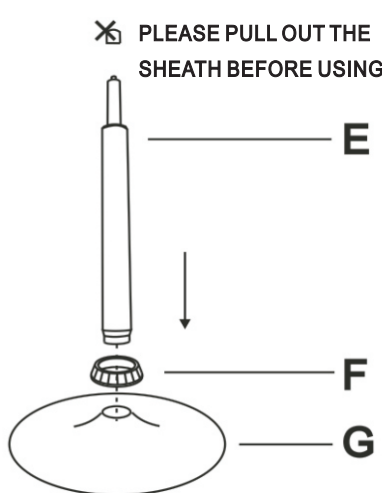
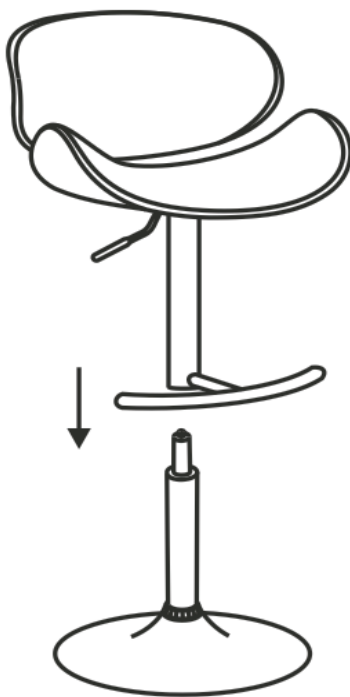
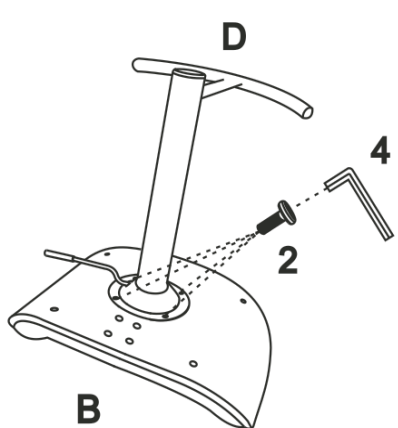
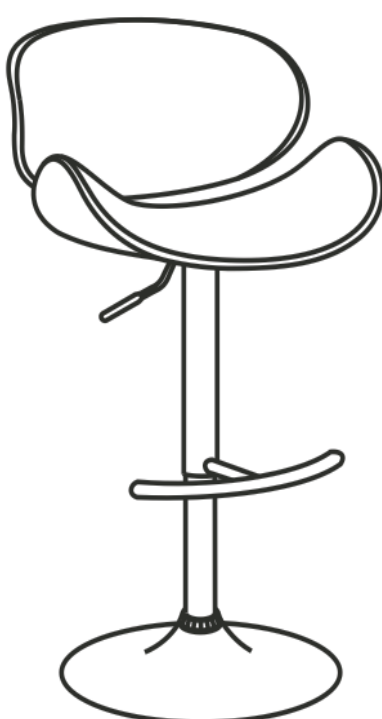
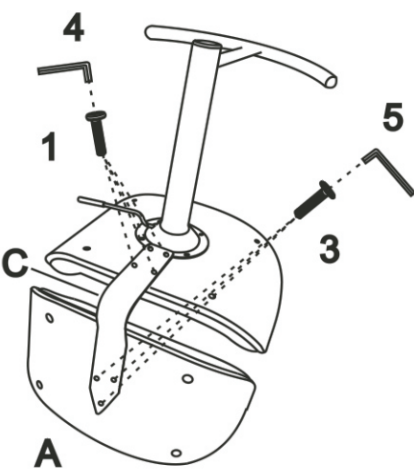
<p>STEP 1</p> <p>✂ PLEASE PULL OUT THE SHEATH BEFORE USING</p>  <p>E</p> <p>F</p> <p>G</p>	<p>STEP 4</p> 
<p>STEP 2</p>  <p>D</p> <p>B</p> <p>2</p> <p>4</p>	<p>STEP 5</p> 
<p>STEP 3</p>  <p>4</p> <p>1</p> <p>C</p> <p>A</p> <p>3</p> <p>5</p>	