

# Assembly Instructions

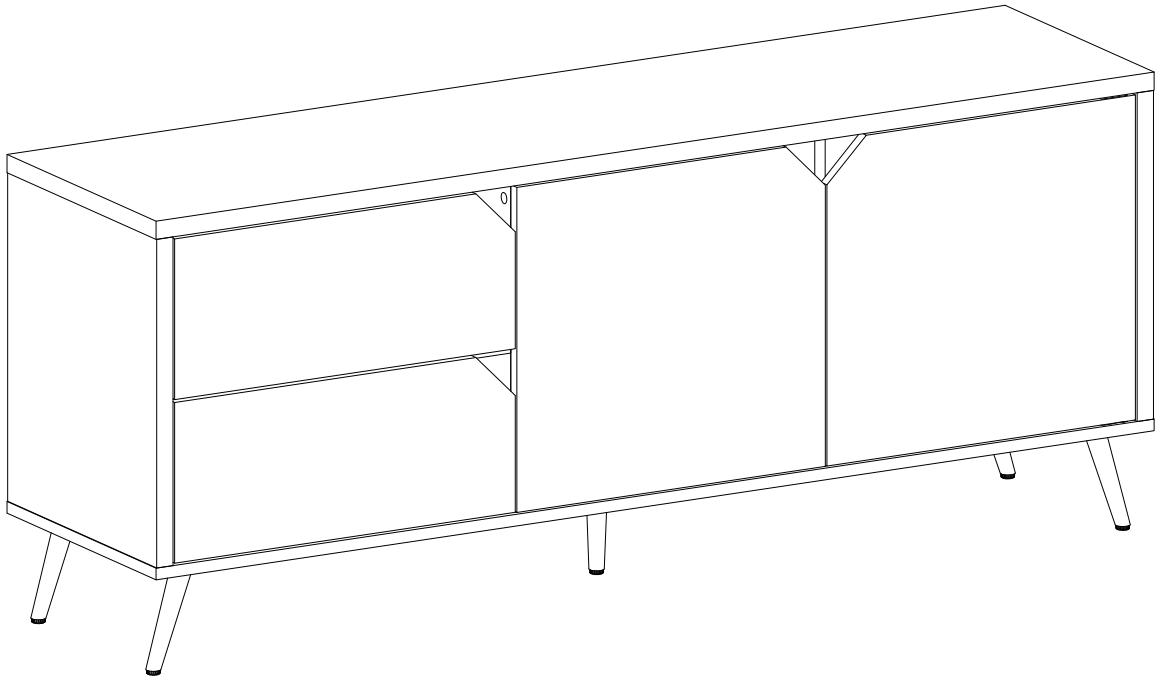

*Please visit our website for the most current instructions, assembly tips, report damage, or request parts.*

# General Assembly Guidelines

- I. Ensure that all parts and hardware are available before beginning assembly.
- II. Follow each step carefully to ensure the proper assembly of this product.
- III. Two people are recommended for ease in the assembly of this product.
- IV. The three main types of hardware used to assemble this product are : wood dowels , screws and bolts.
- V. The provided glue is to secure wood dowels in place . When first inserting dowels , locate the appropriate hole for the dowel , place a small amount of glue in the hole and insert the dowel . Wipe away excess glue immediately.

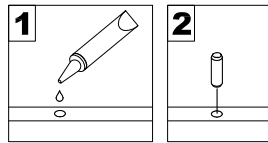

In future assembly steps when dowels are necessary to attach assembly parts together , place a small amount of glue on the end of the dowel before attaching parts together . Wipe away excess glue immediately.

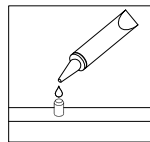

- VI. A Phillips head screwdriver is required for the assembly of this product .

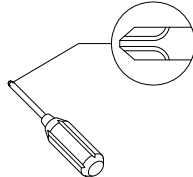

- VII. Power tools should not be used to assemble this product .

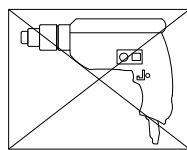

- VIII. Concealed hinges are three-way adjustable.

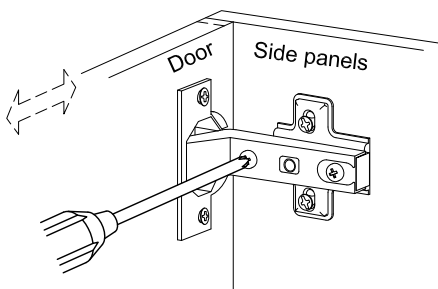

Horizontal  
by screw adjustment

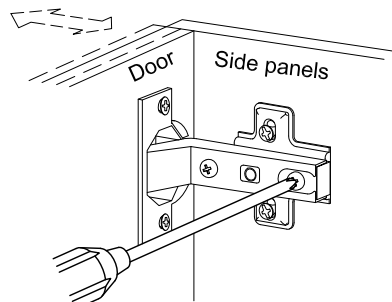

In-and-Out  
by loosening the hinge-arm  
mounting screw or via cam  
adjustment

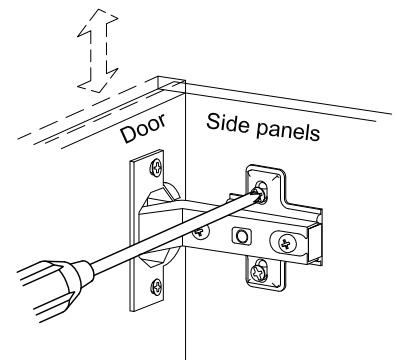





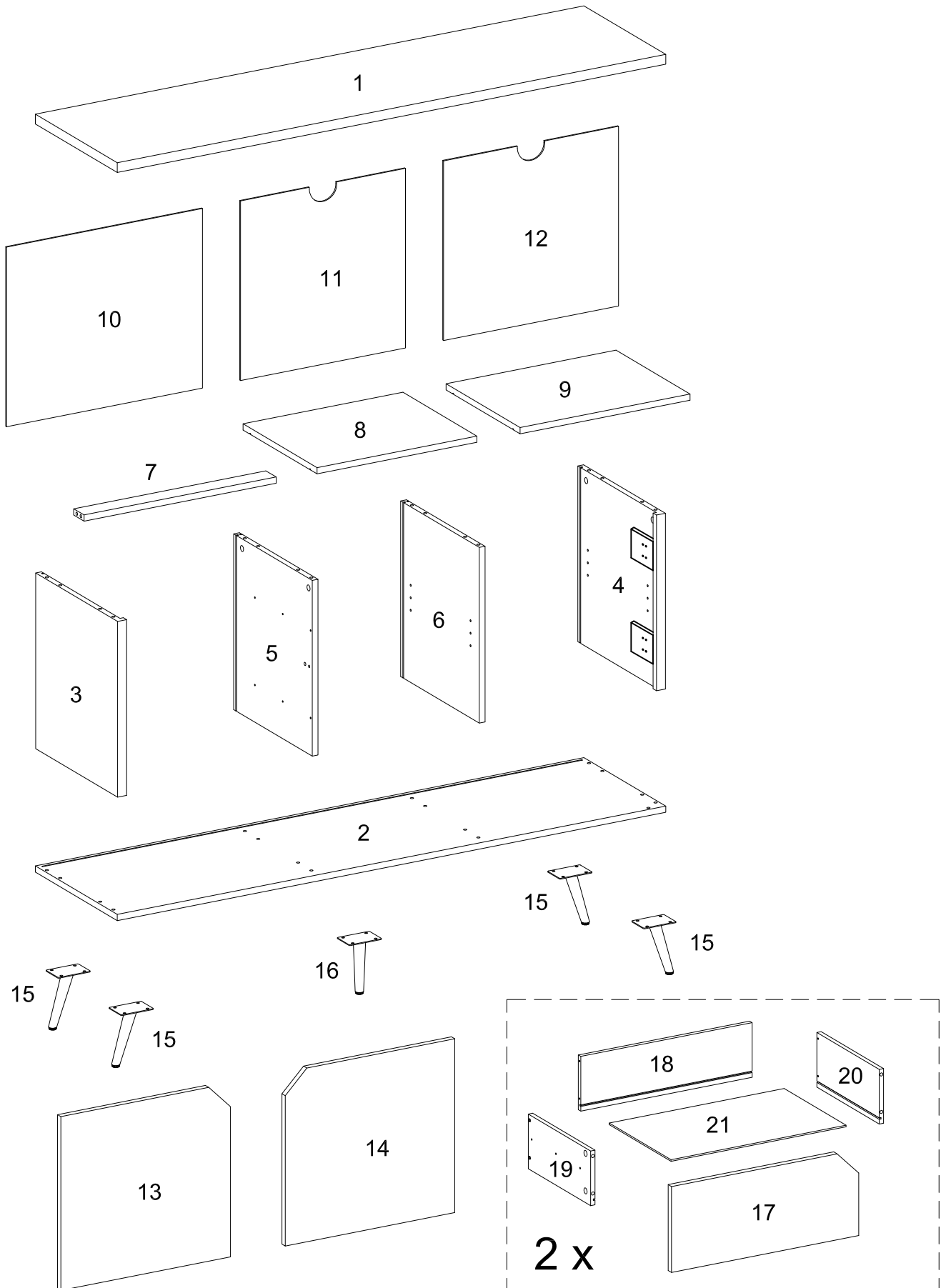







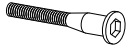

Vertical  
Via slots in the mounting  
plate or via cam adjustment

# Parts List

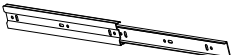

# Hardware List

A		Ø8x30mm	Wooden dowel	18 pcs
B		Ø6x35mm	Cam bolt	18 pcs
C		Ø15x11mm	Cam lock	10 pcs
D		Ø15x 9 mm	Cam lock	8 pcs
E		Ø30mm	Sticker	18 pcs
F		Ø6x50mm	Screw	8 pcs
G		Ø6x12mm	Bolt	20 pcs
H		M4	Hex Key	1 pc
J		Ø8x5x16mm	Shelf support pin	8 pcs
K		Ø3x17mm	Screw	12 pcs
L			Plastic wedge	12 pcs
M		Ø4x35mm	Screw	8 pcs
N		Ø3x12mm	Screw	48 pcs
P			Hinge	2 pcs
Q			Hinge	2 pcs
R			Drawer slider	2 sets

\* Note: This piece comes preassembled for shipping purposes and must be disassembled to complete the desk assembly.

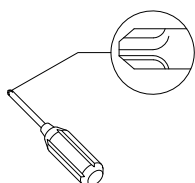

Philips head screwdriver required for assembly  
(not included)

*The hardware quantities listed above are required for proper assembly.  
Some extra hardware may also have been included.*

# Step 1

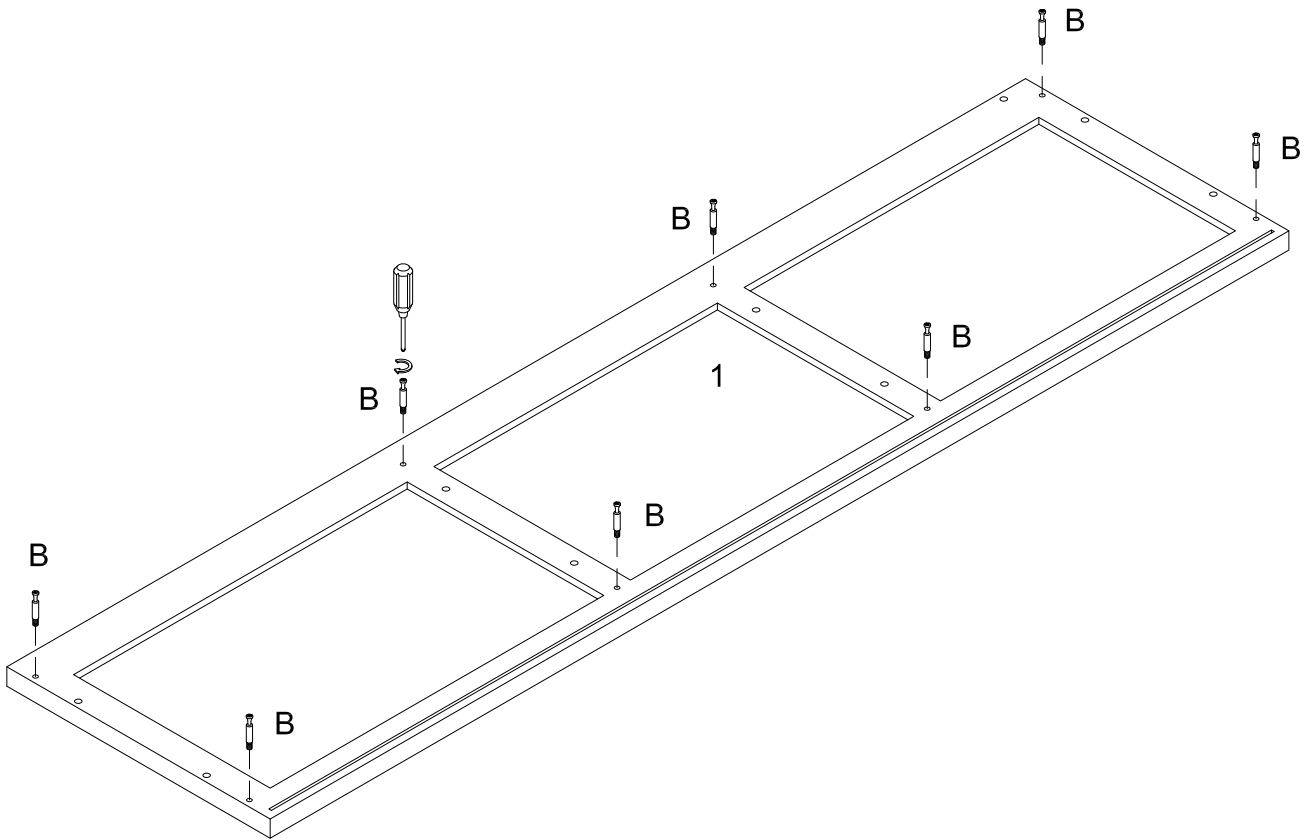

Secure cam bolt (B) into part (1).

# Step 2

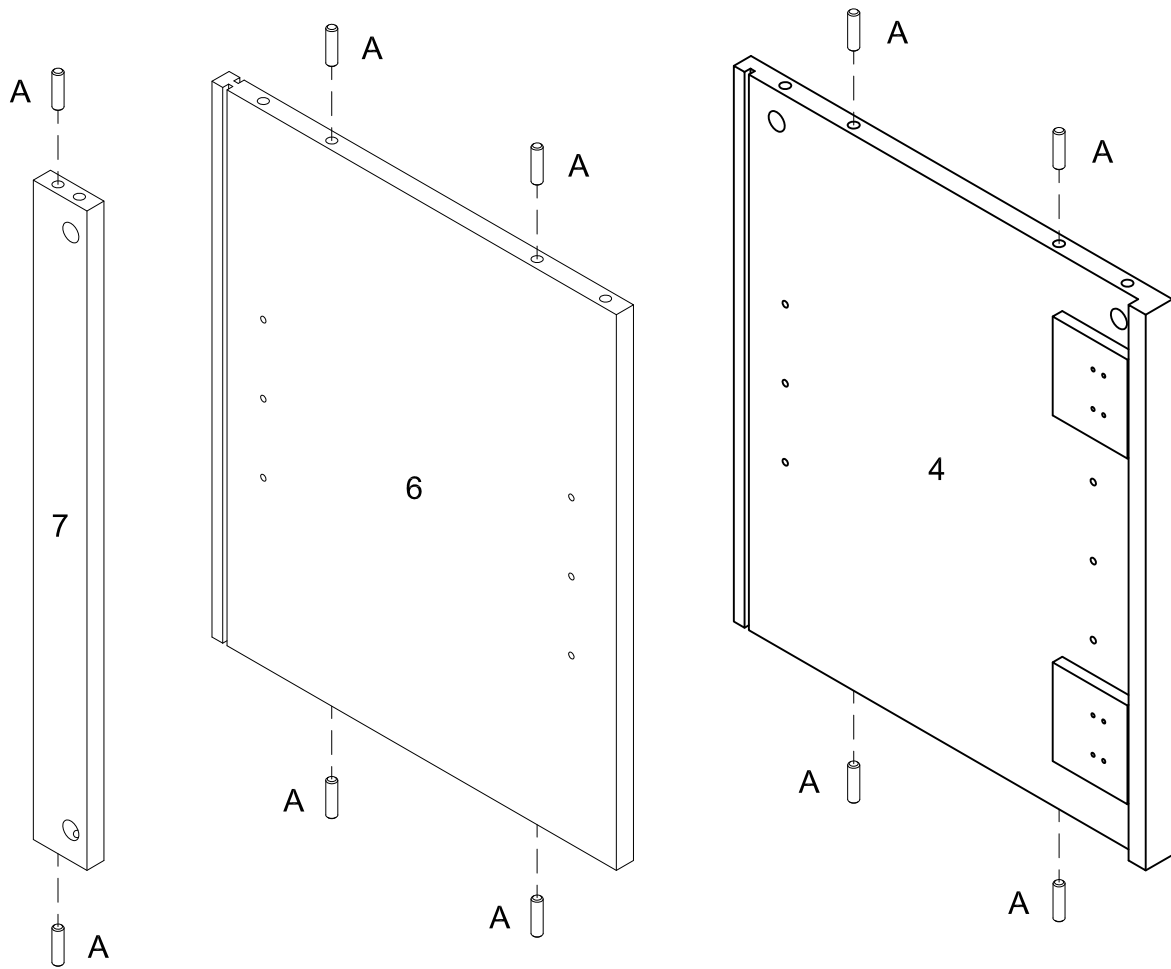

Insert wooden dowel (A) into part (4, 6, 7) as per diagram.

# Step 3

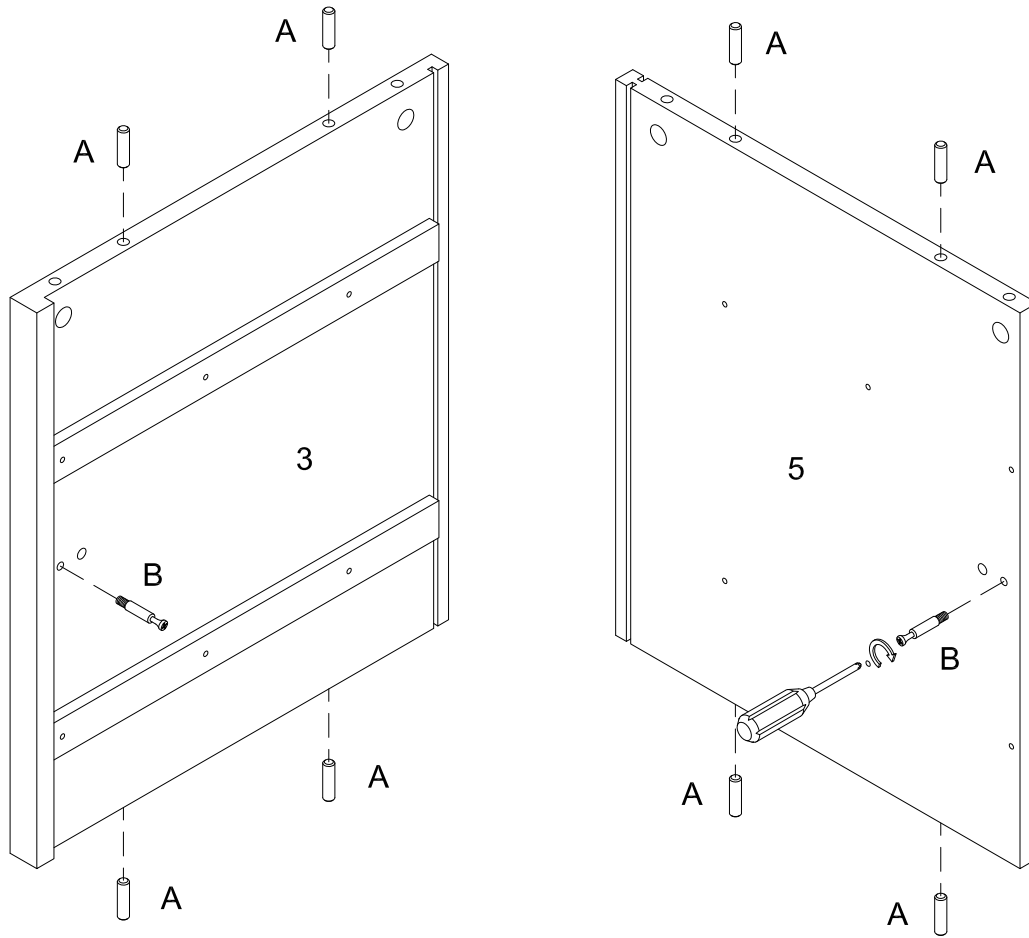

Insert wooden dowel (A) into part (3, 5), secure cam bolt (B) into part (3, 5) as per diagram.

# Step 4

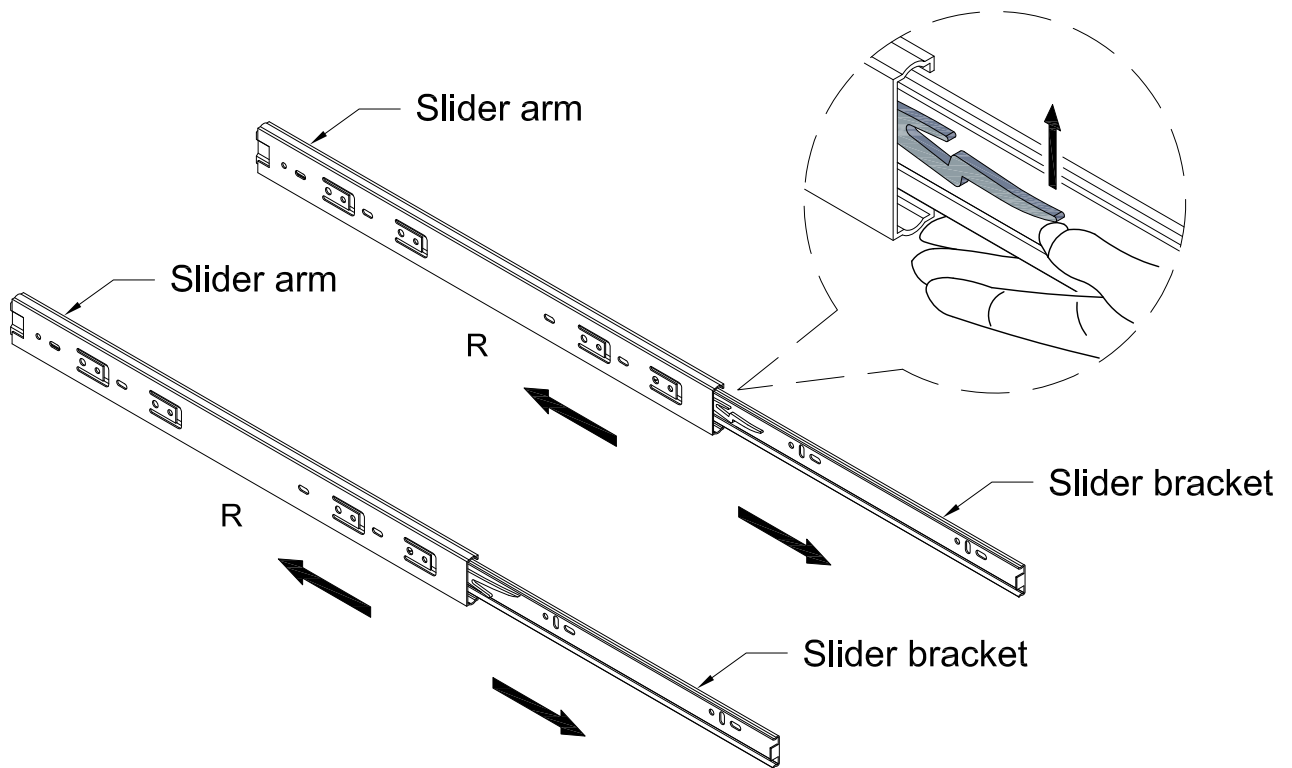

Disassemble drawer slider (R) by sliding the slider arm and slider bracket apart. Depress the small lever of the slider bracket and carefully pull the two pieces apart. Repeat this process for both drawer sliders (R).

# Step 5

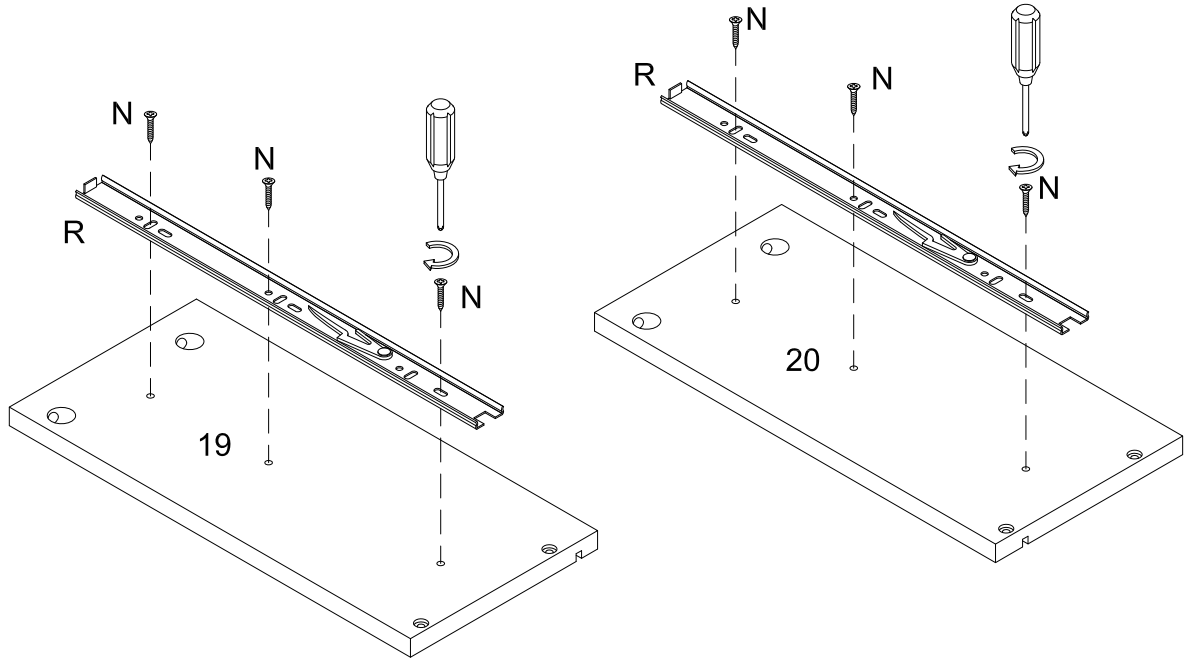

Secure slider bracket of drawer slider (R) to part (19, 20) using screw (N) with Philips screwdriver. Repeat this process for both drawers.

# Step 6

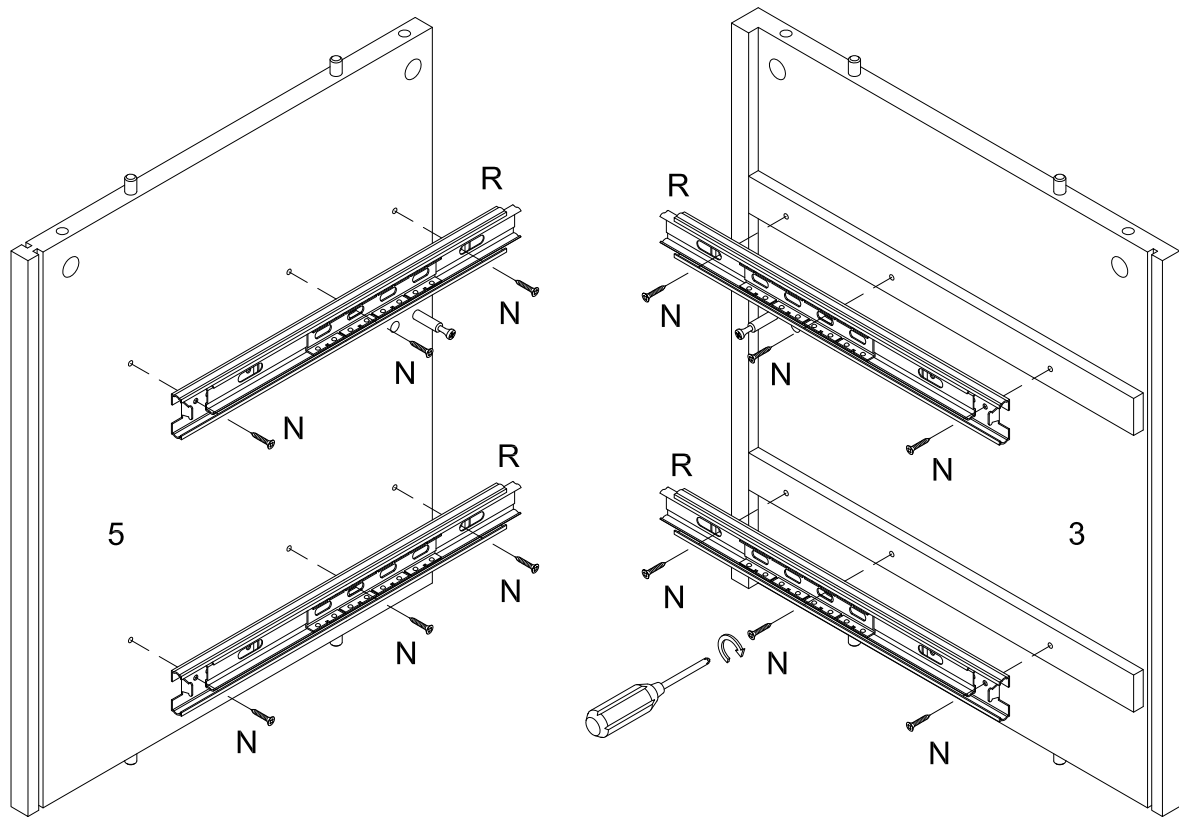

Secure slider arms of 2 sets drawer slider (R) to part (3, 5) using screw (N) with Philips screwdriver.

# Step 7

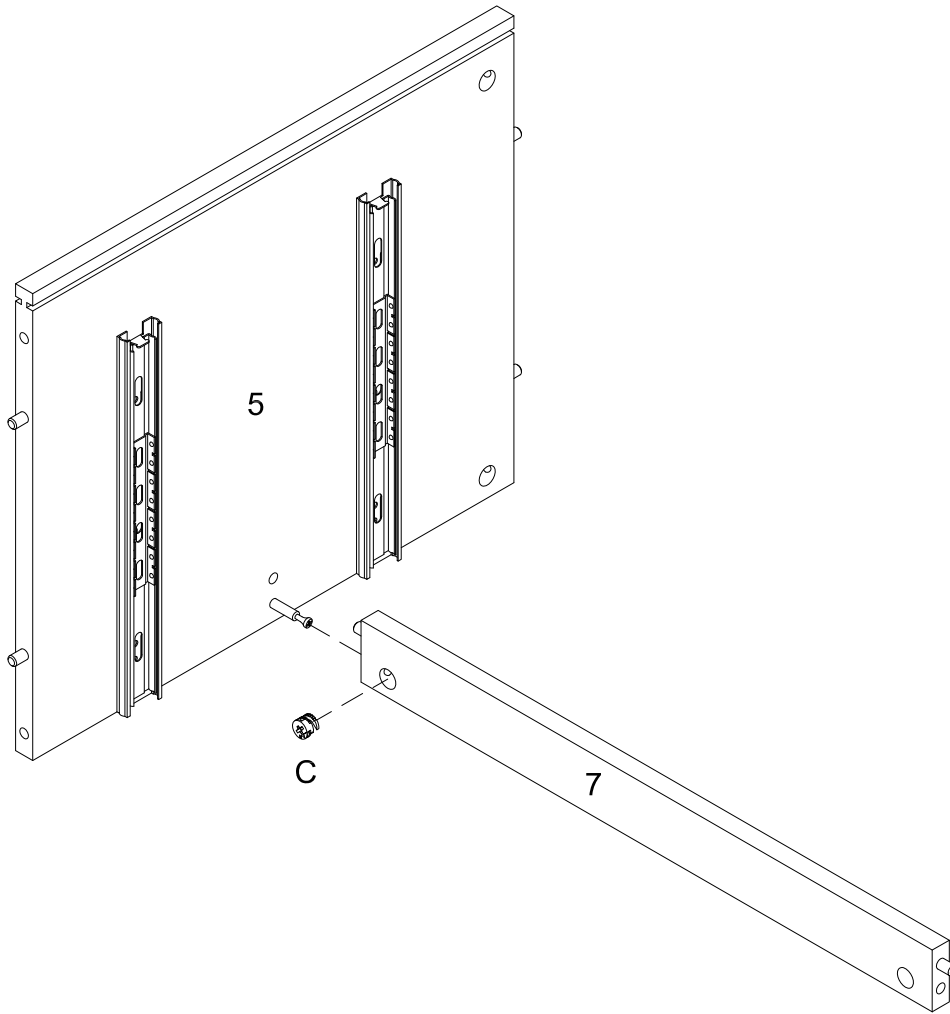
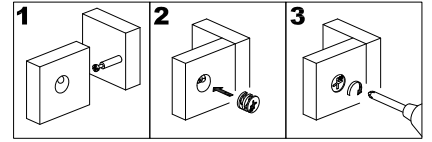

Secure part (7) to part (5) using cam lock (C) as per diagram.

# Step 8

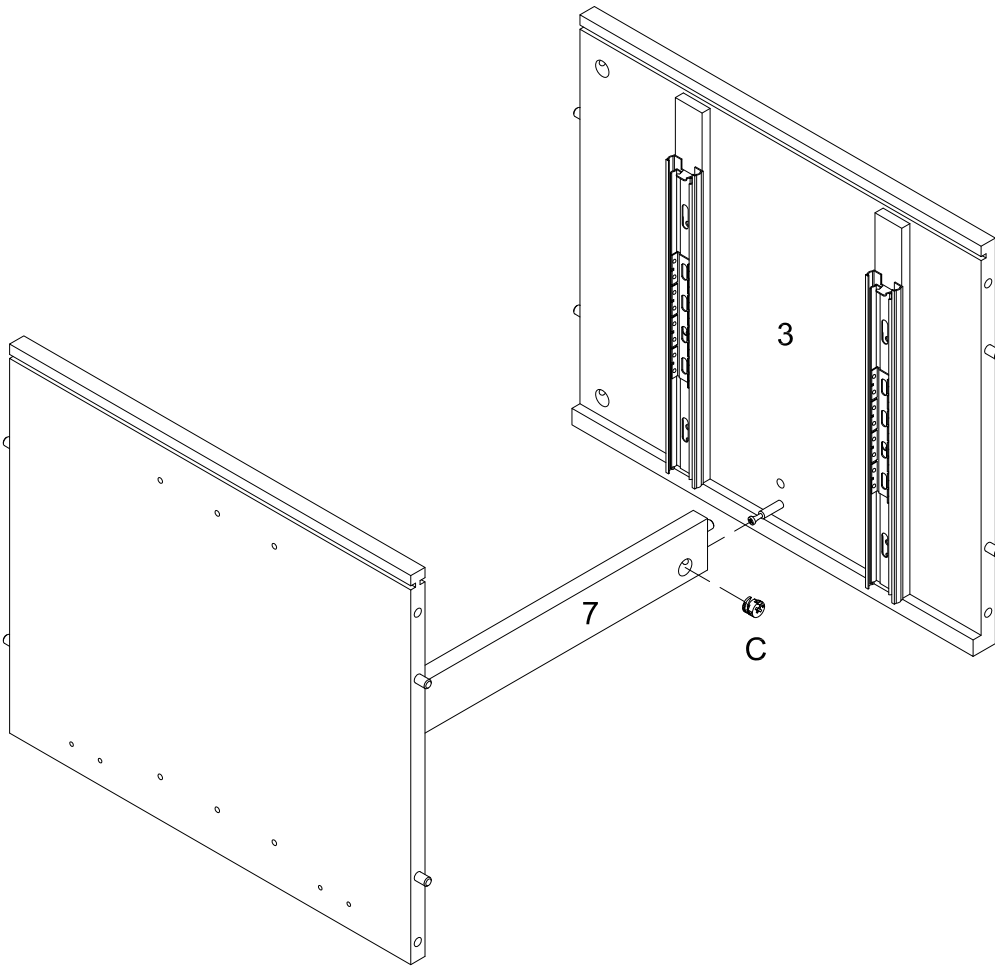
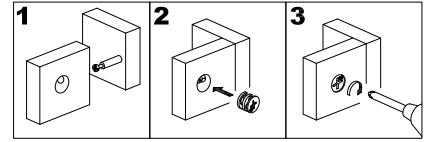

Secure part (7) to part (3) using cam lock (C) as per diagram.

# Step 9

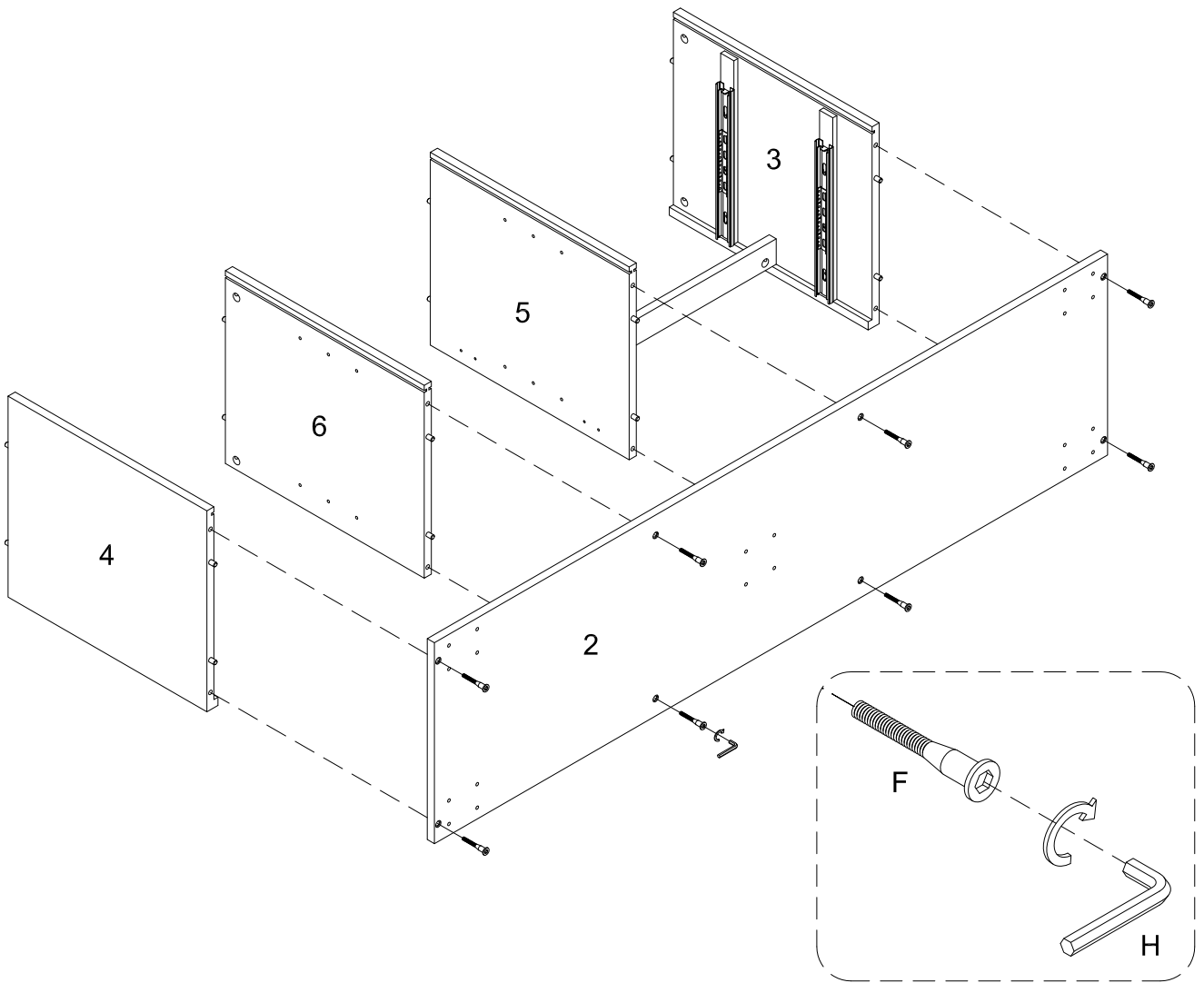

Attach part (2) to part (4, 6, 5, 3) using screw (F) with hex key (H) as per diagram.

# Step 10

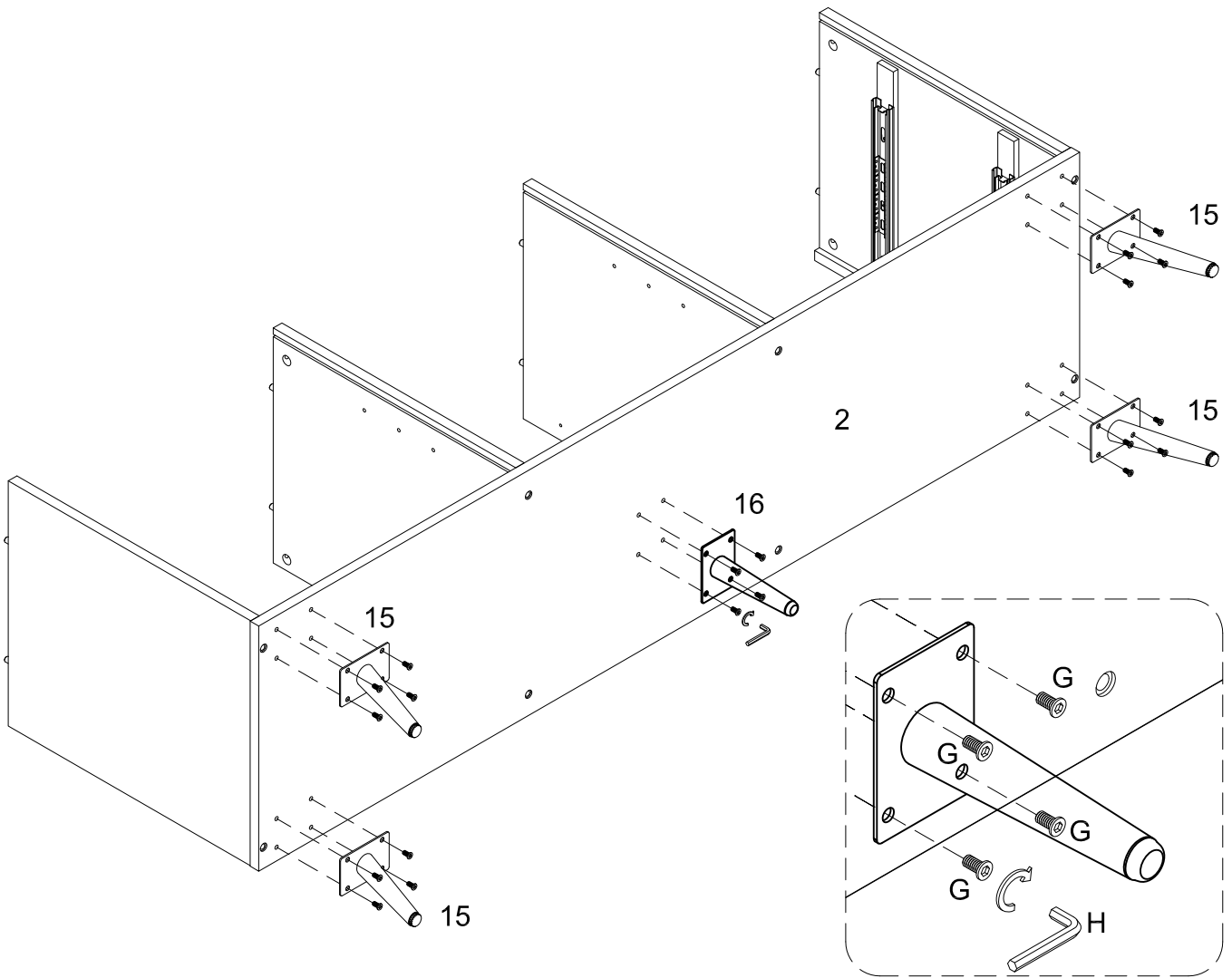

Attach part (15, 16) using bolt (G) with hex key (H) as per diagram.

# Step 11

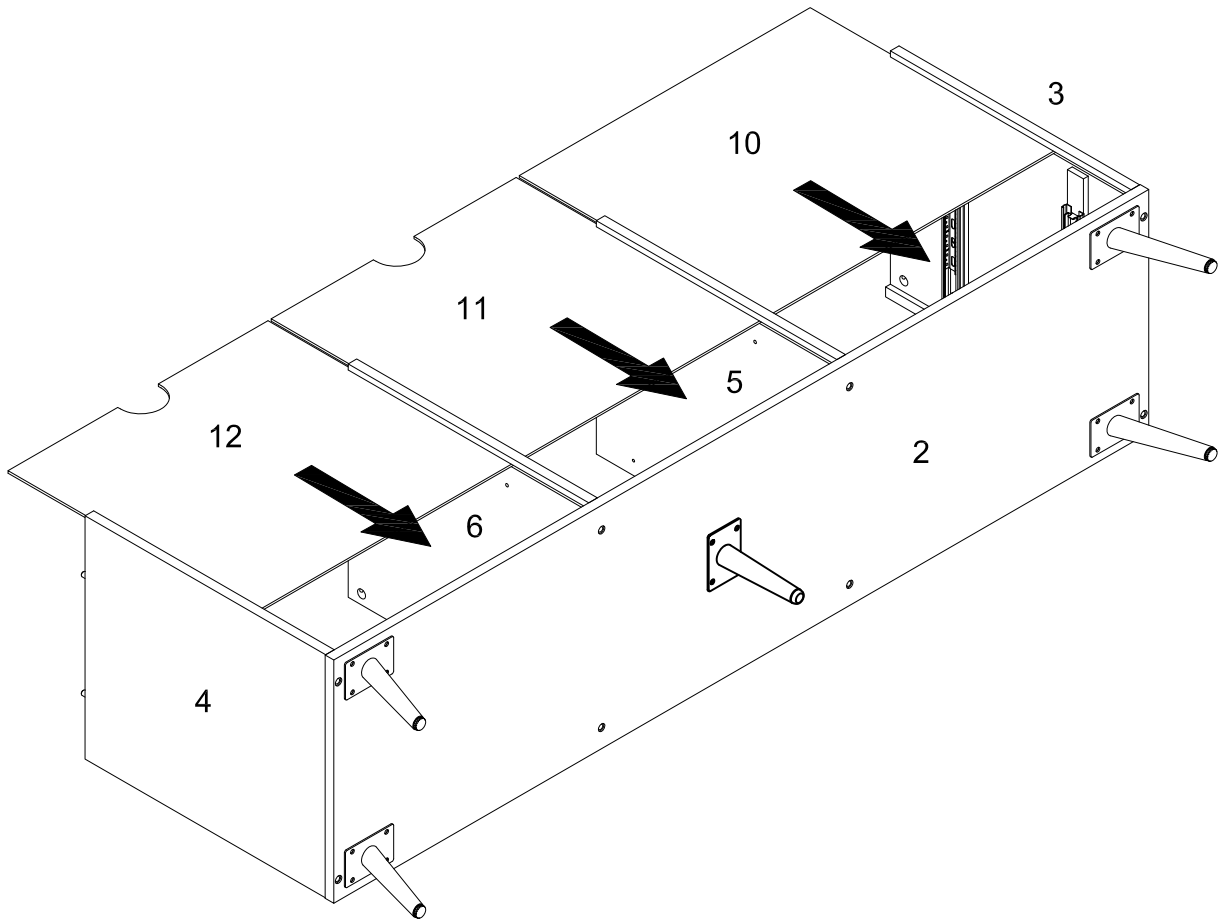

Insert part (10, 11, 12) into grooves of part (2, 3, 5, 6, 4) as per diagram.

# Step 12

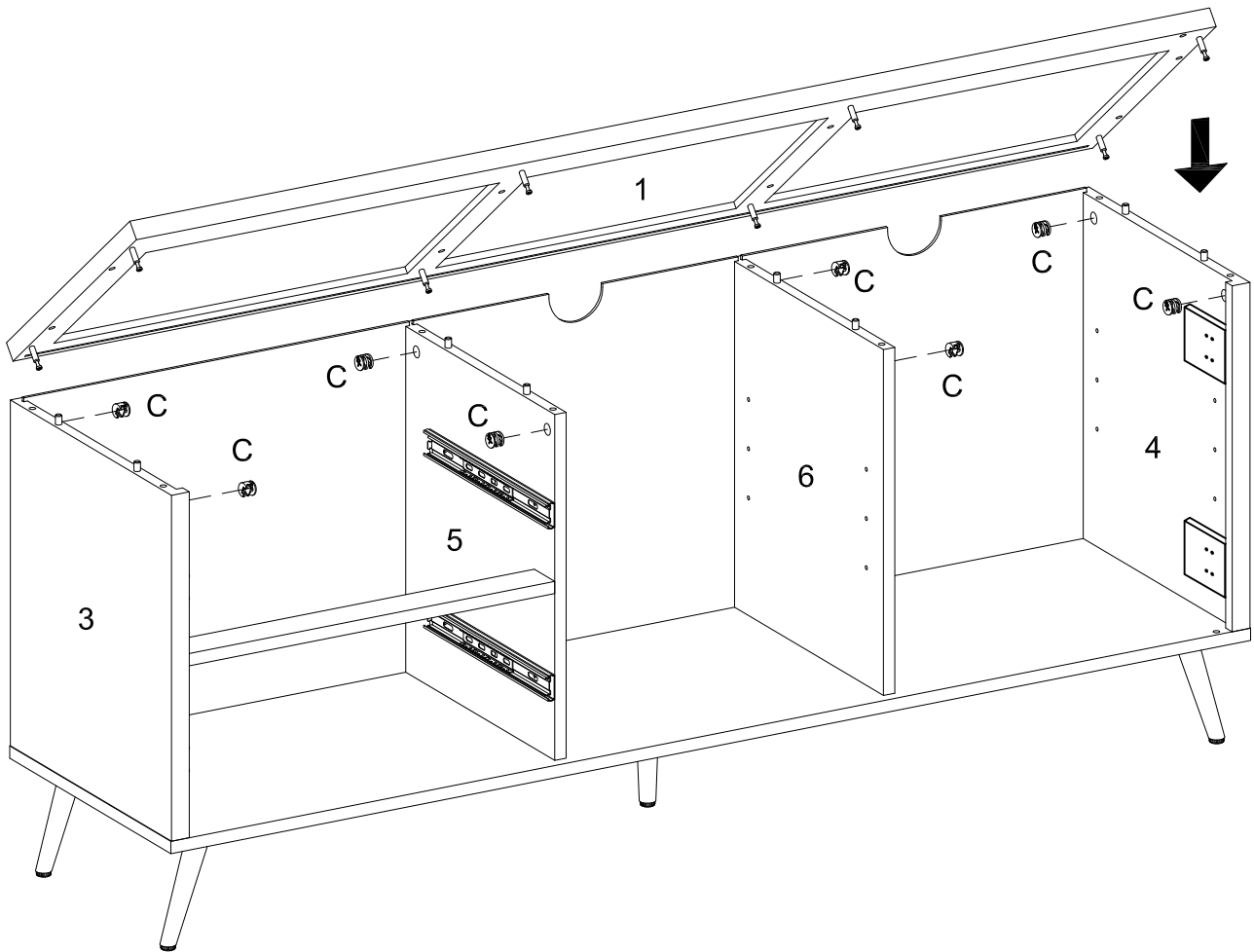
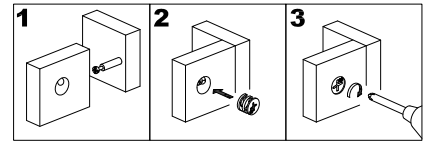

Secure part (1) to part (3, 5, 4, 6) using cam lock (C) as per diagram.

# Step 13

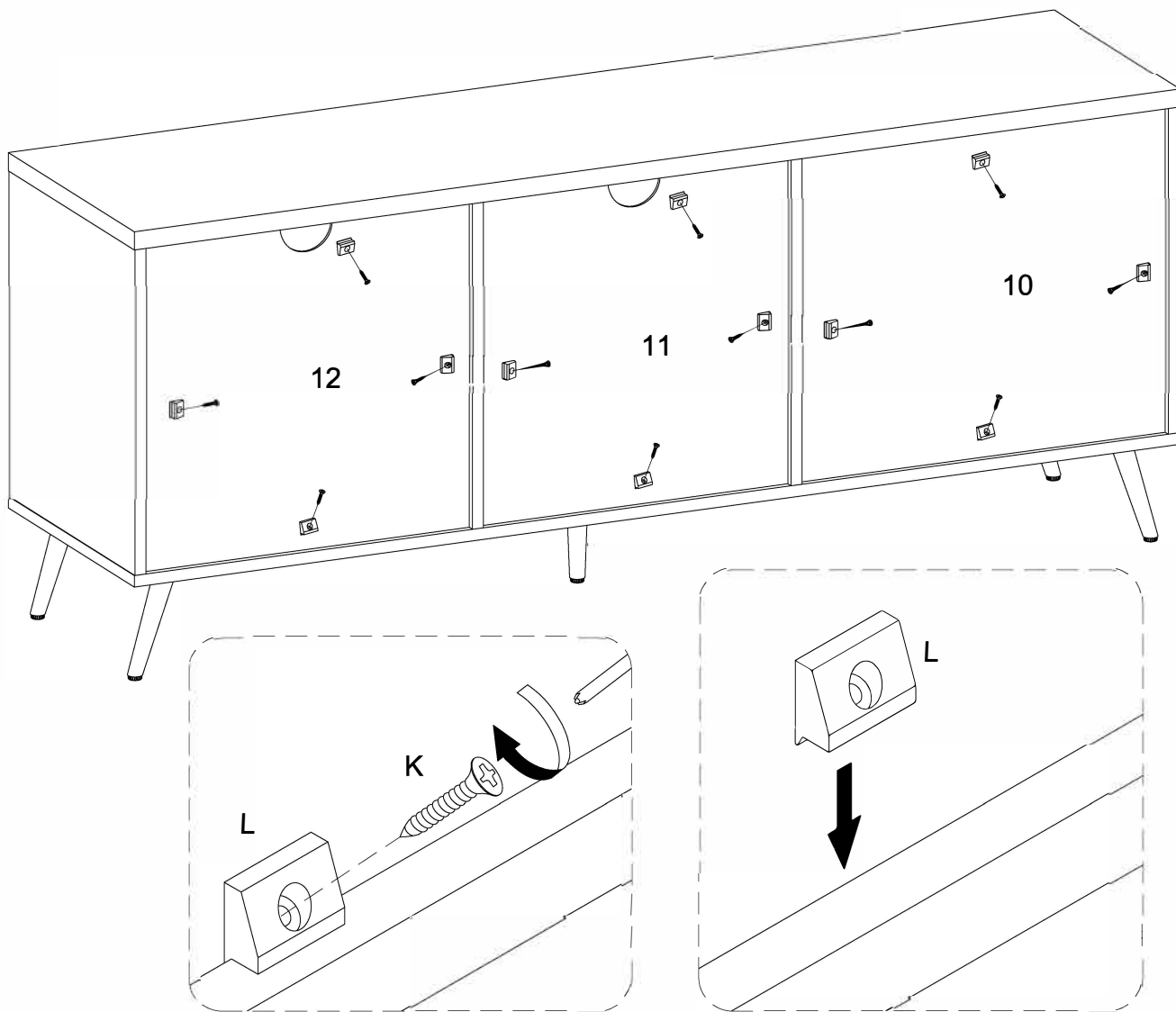

Attach plastic wedge (L) using screw (K) with Philip head screwdriver.

# Step 14

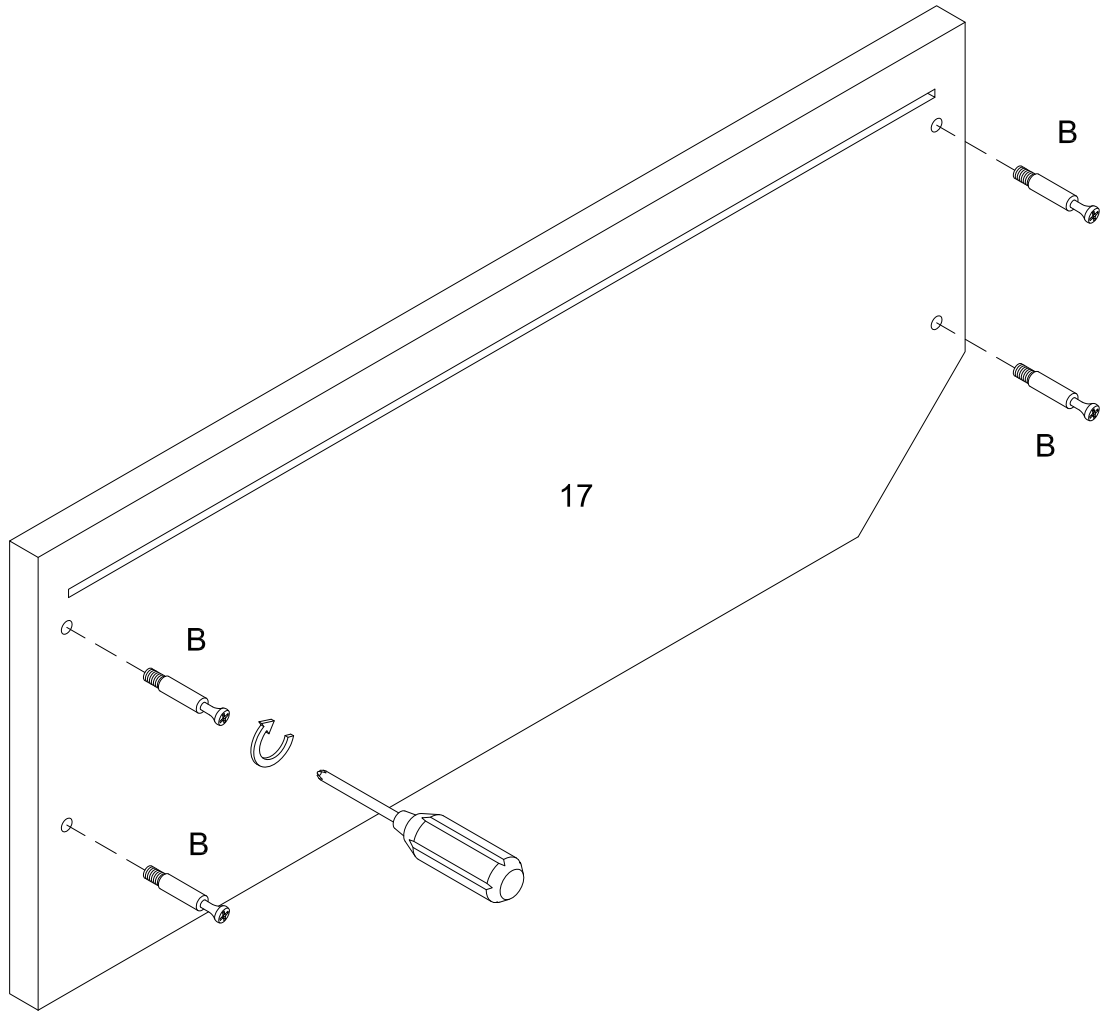

Secure cam bolt (B) into part (17). Repeat this process for twice.

# Step 15

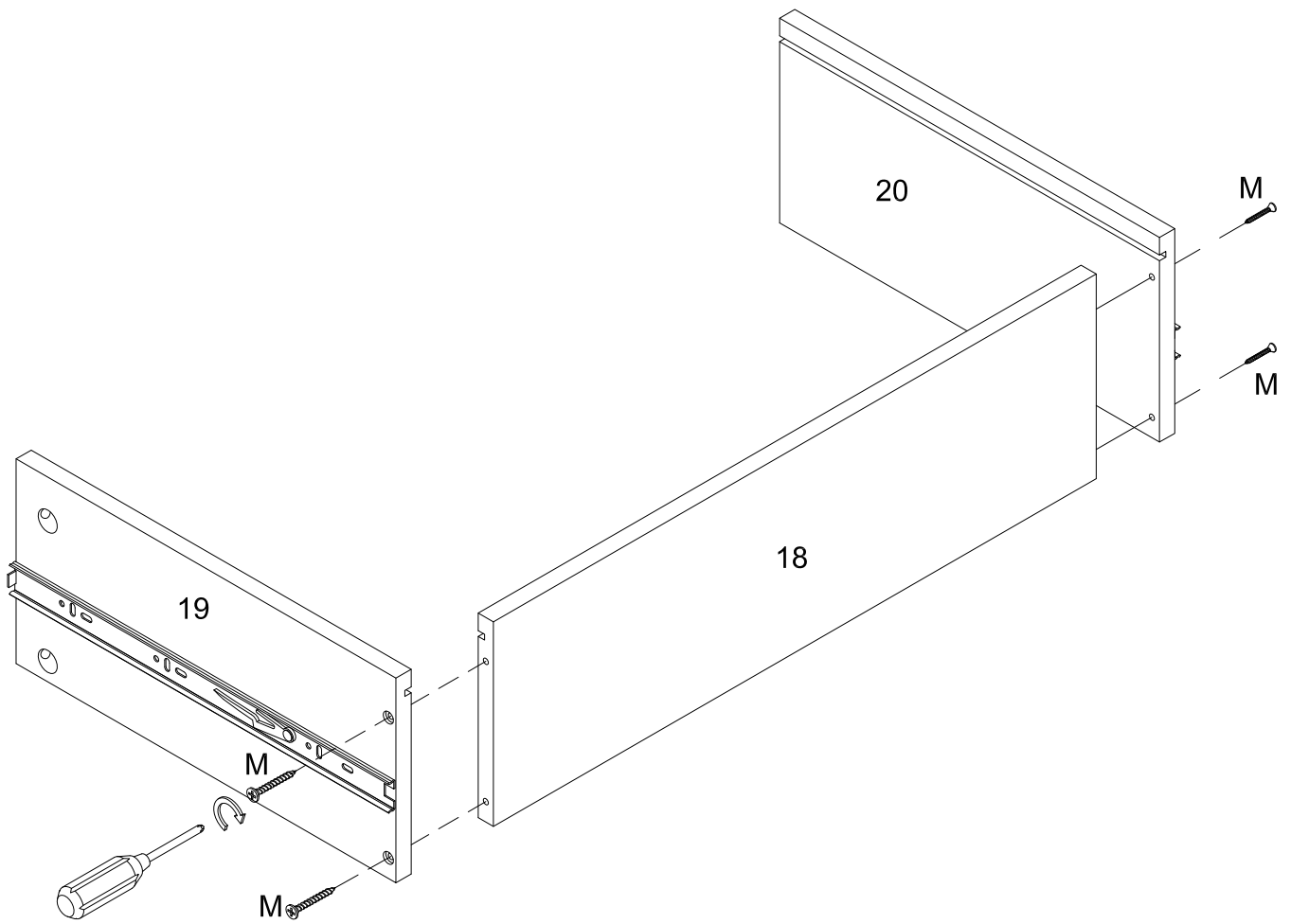

Attach part (19, 20) to part (18) using screw (M) with Philip head screwdriver. Repeat this process for twice.

# Step 16

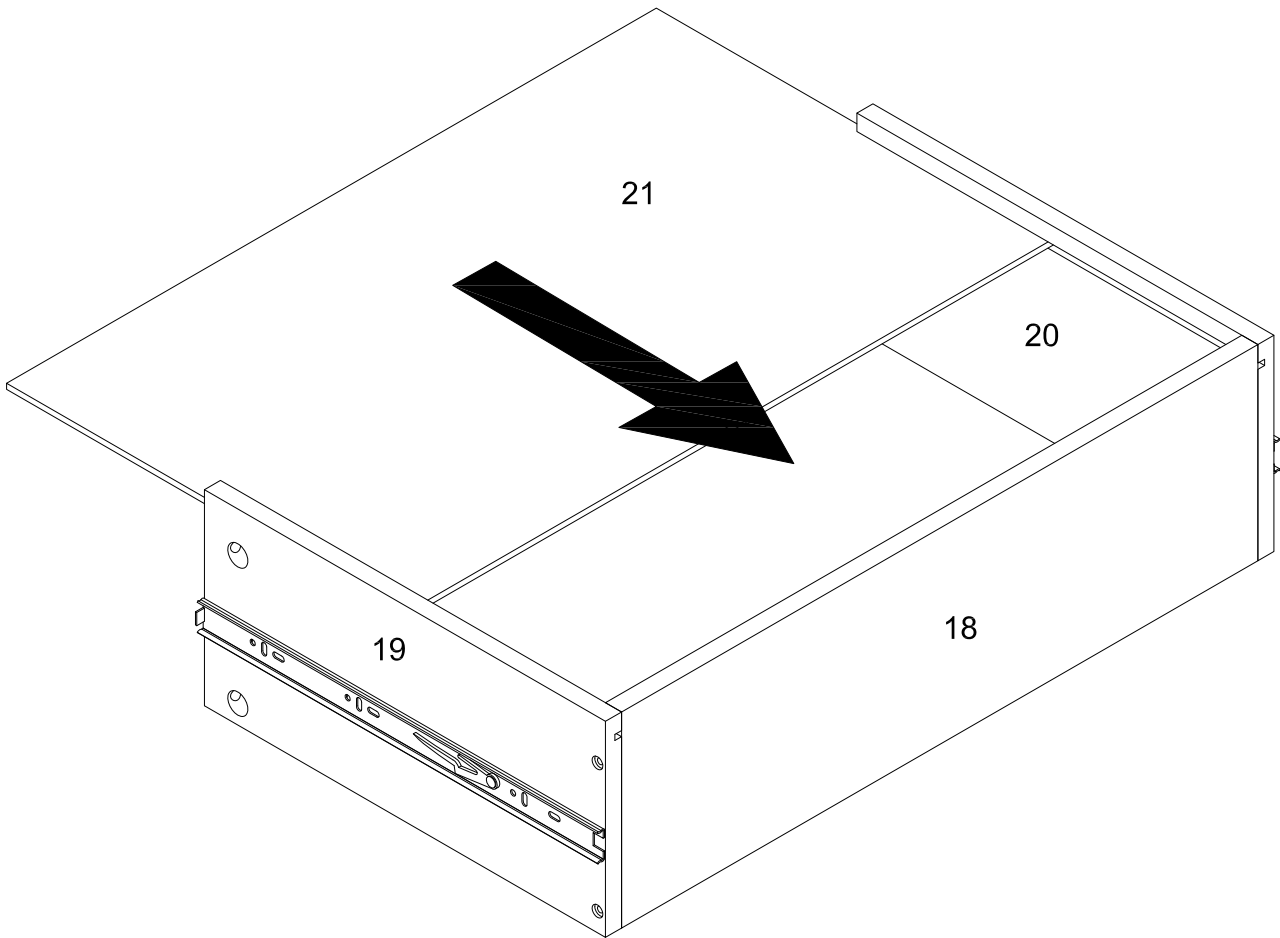

Insert part (21) into grooves of part (19, 18, 20) as per diagram. Repeat this process for twice.

# Step 17

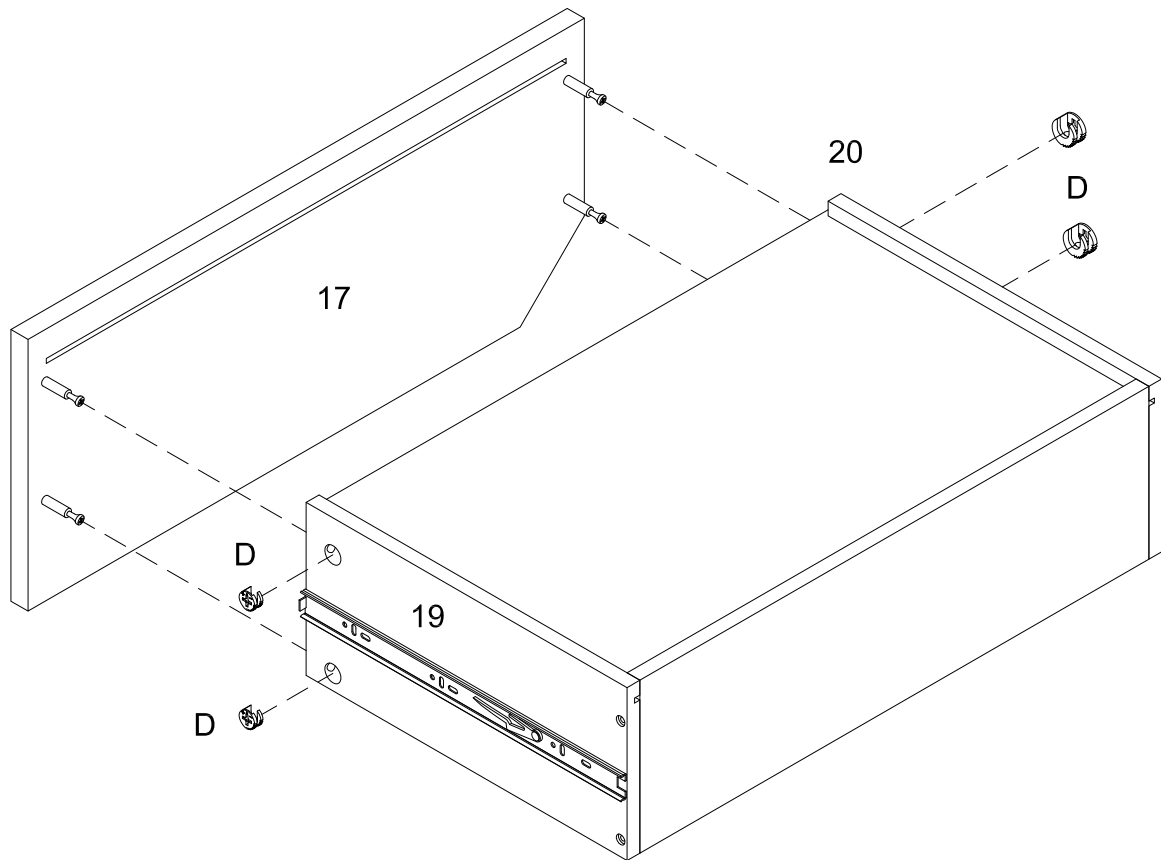
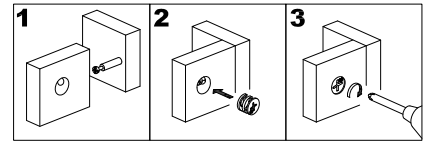

Attach part (17) to part (19, 20) using cam lock (D) as per diagram. Repeat this process for twice.

# Step 18

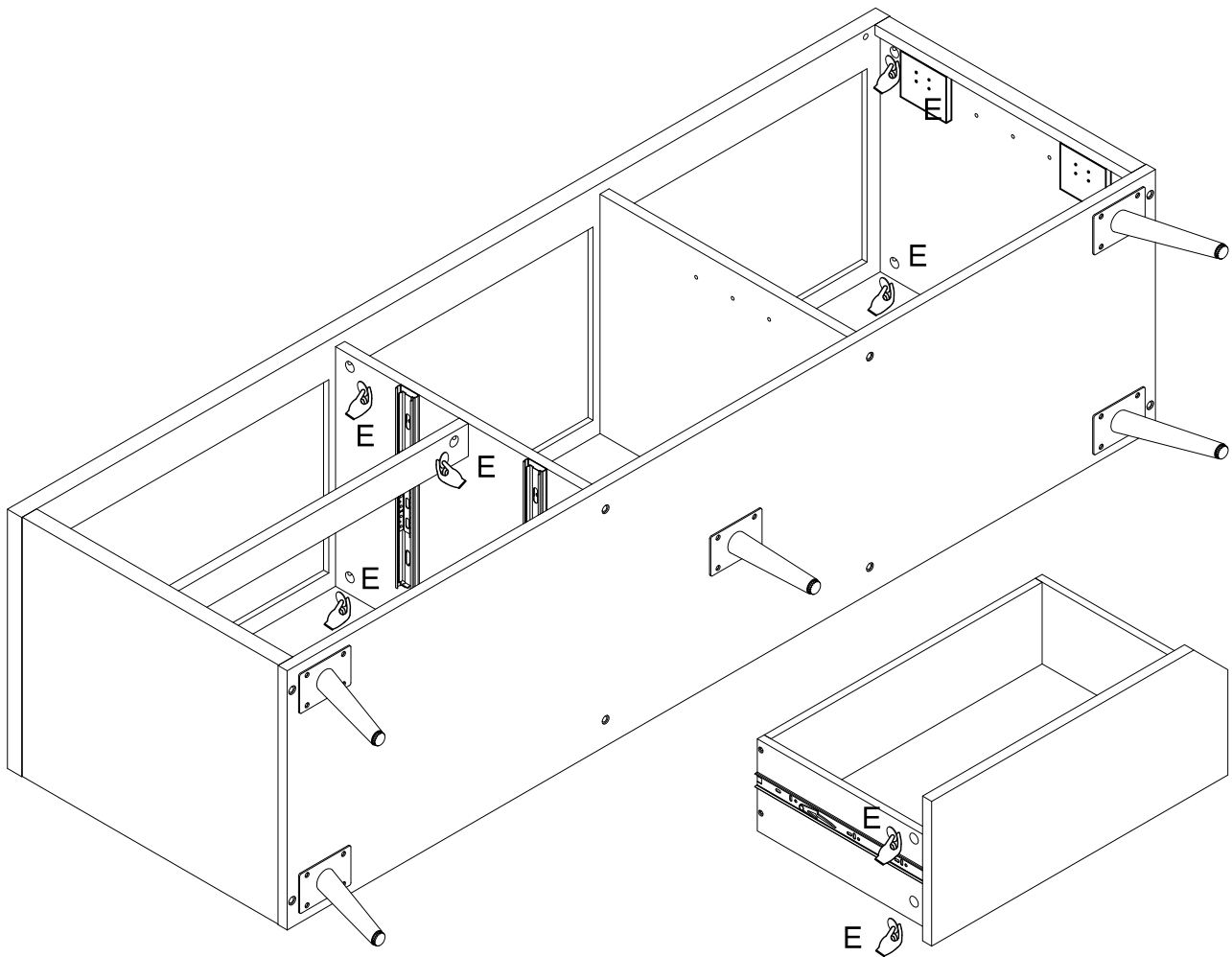

Place sticker (E) over holes as per diagram.

# Step 19

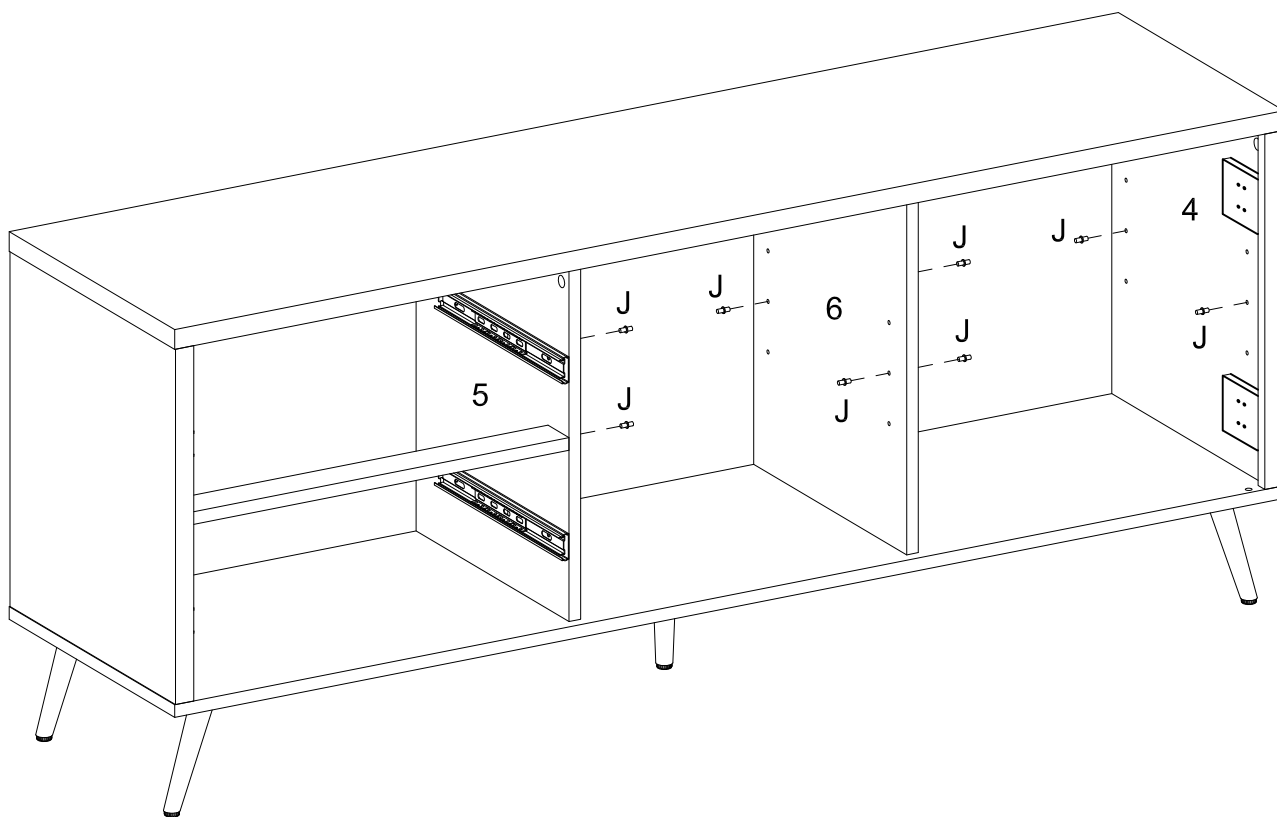

Insert shelf support pin (J) to part (5, 6, 4) as per diagram.

## Step 20

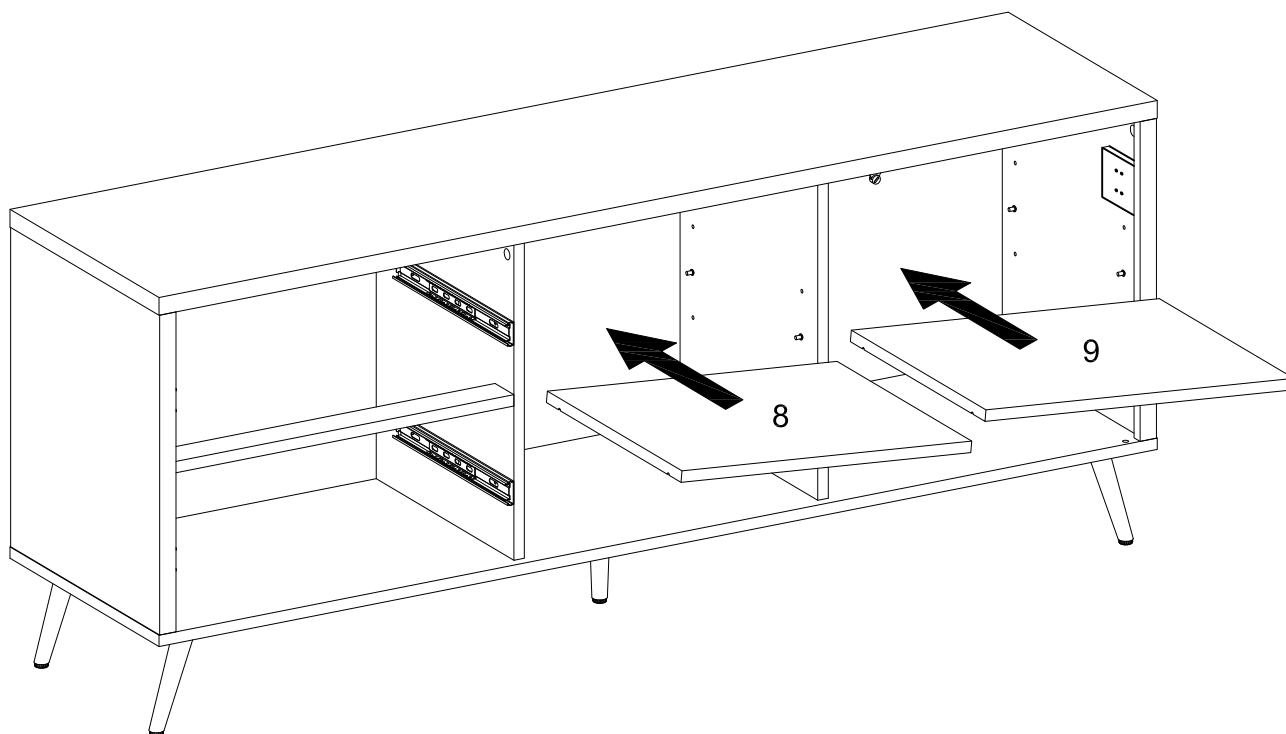

Place part (8, 9) onto shelf support pins as per diagram.

# Step 21

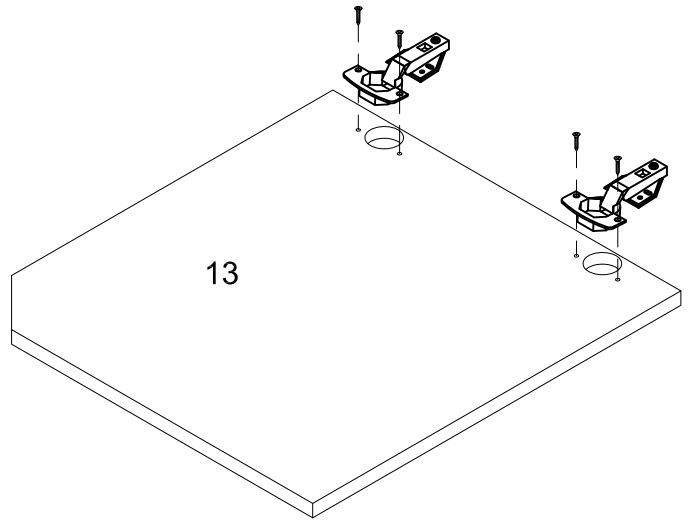
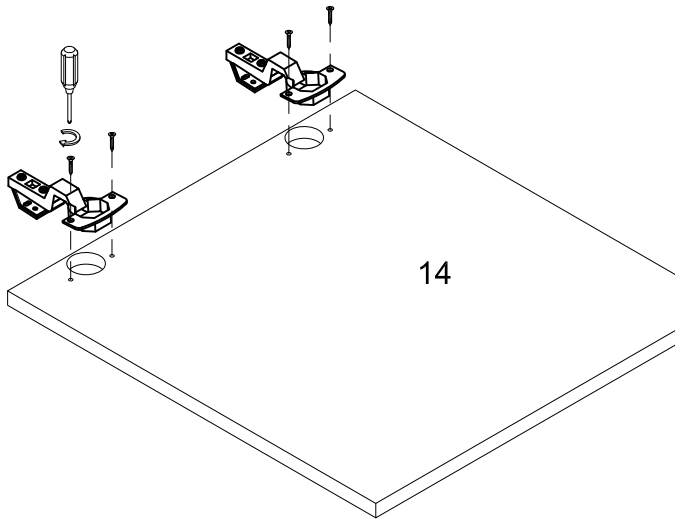
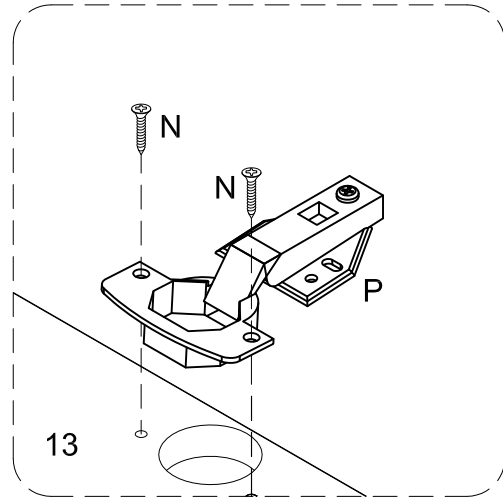
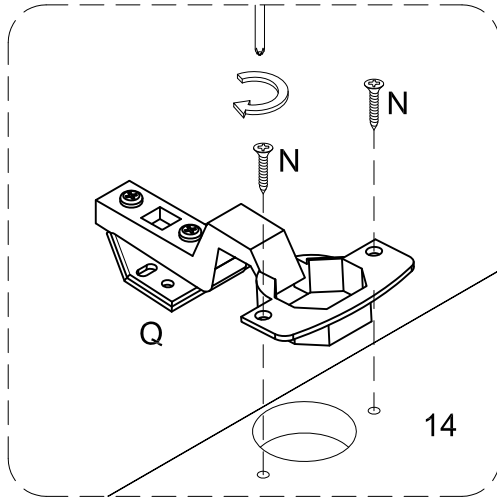

Secure hinge (Q) to part (14), hinge (P) to part (13) using screw (N) with Philips head screwdriver as per diagram.

# Step 22

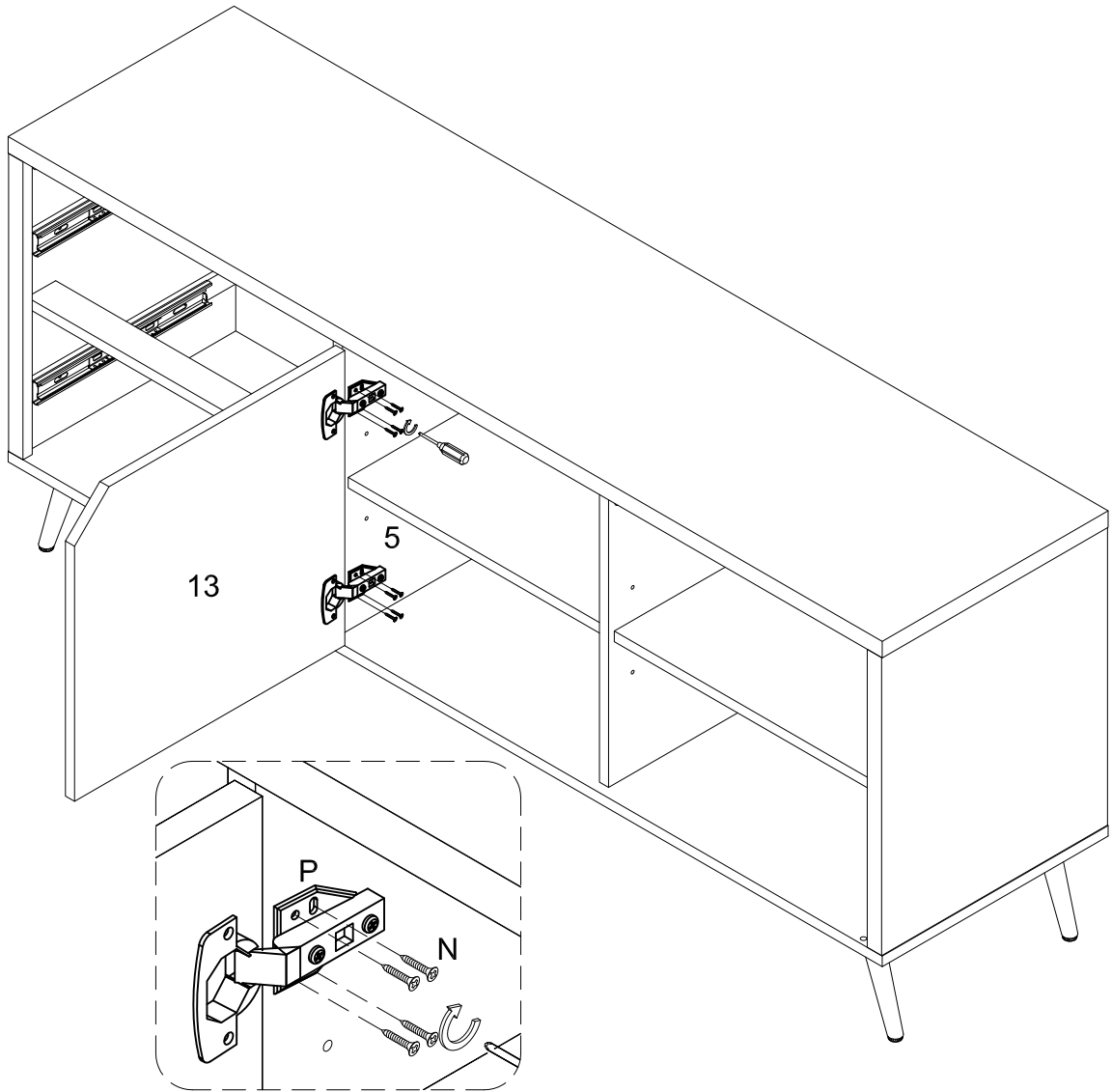

Attach part (13) to part (5) using screw (N) with Philips head screwdriver as per diagram.

# Step 23

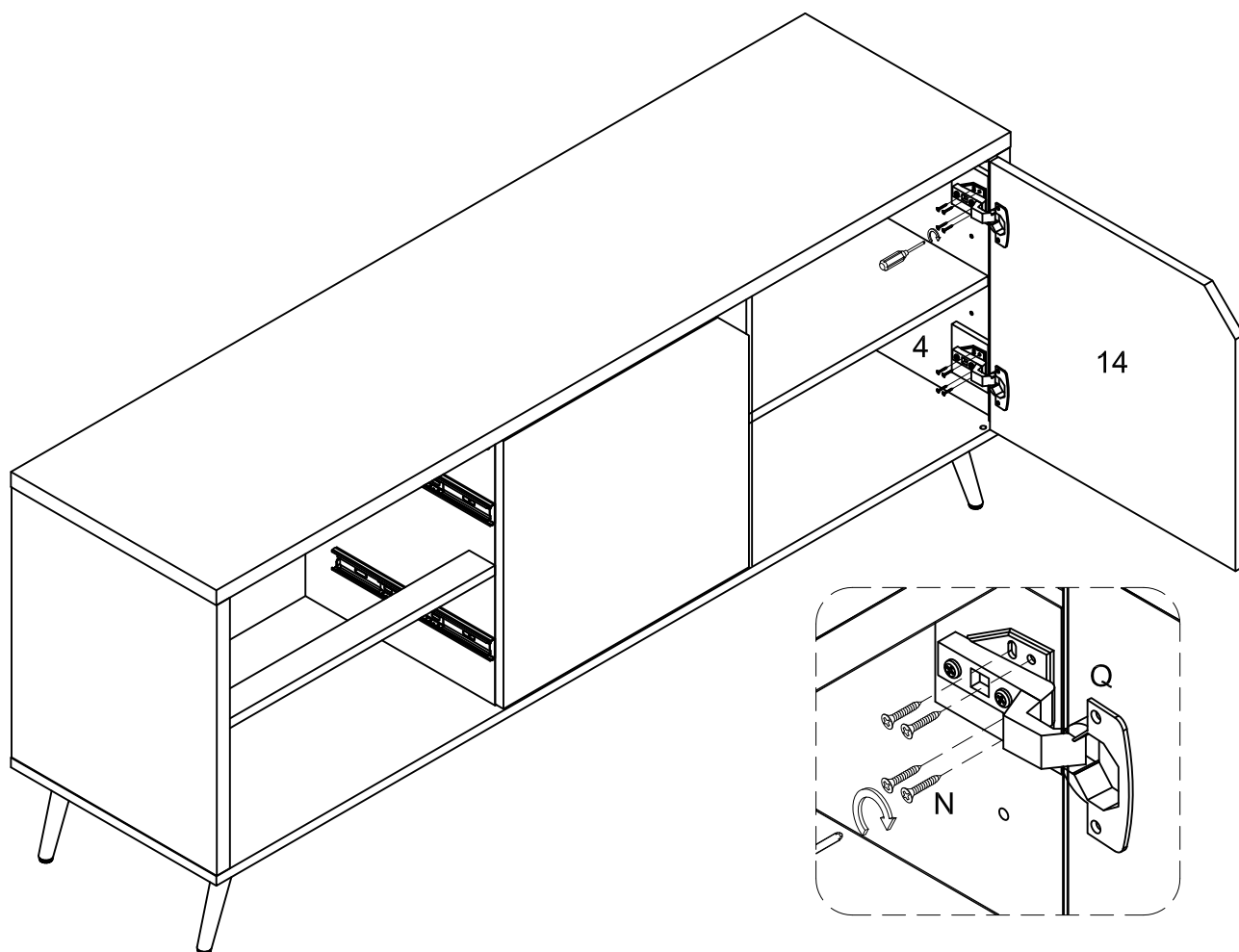

Attach part (14) to part (4) using screw (N) with Philips head screwdriver as per diagram.

# Step 24

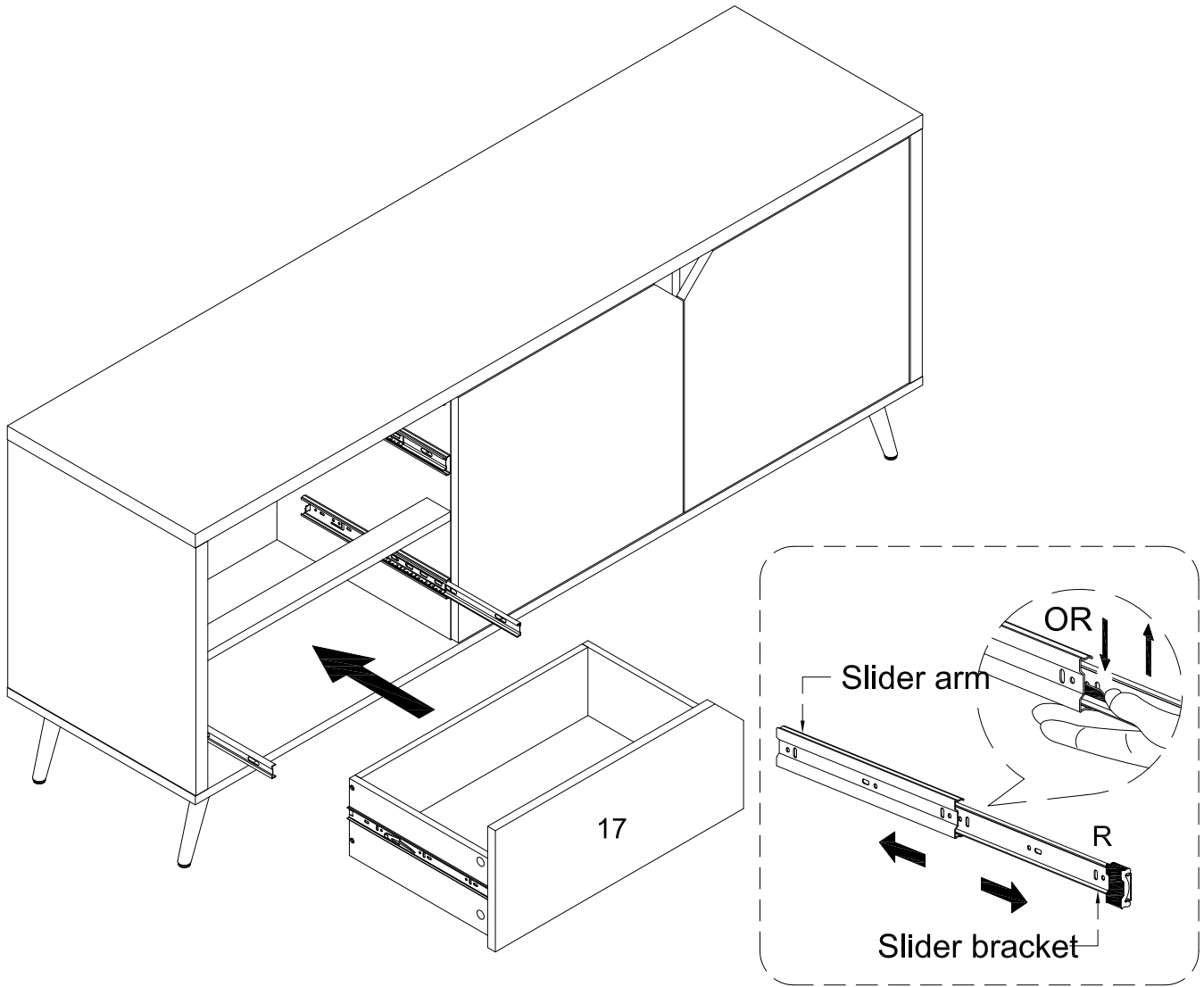

Press down/up on slider bracket of drawer slider (R) lock, then insert the drawer into slider arm to lock it. Repeat this step twice.

# Step 25

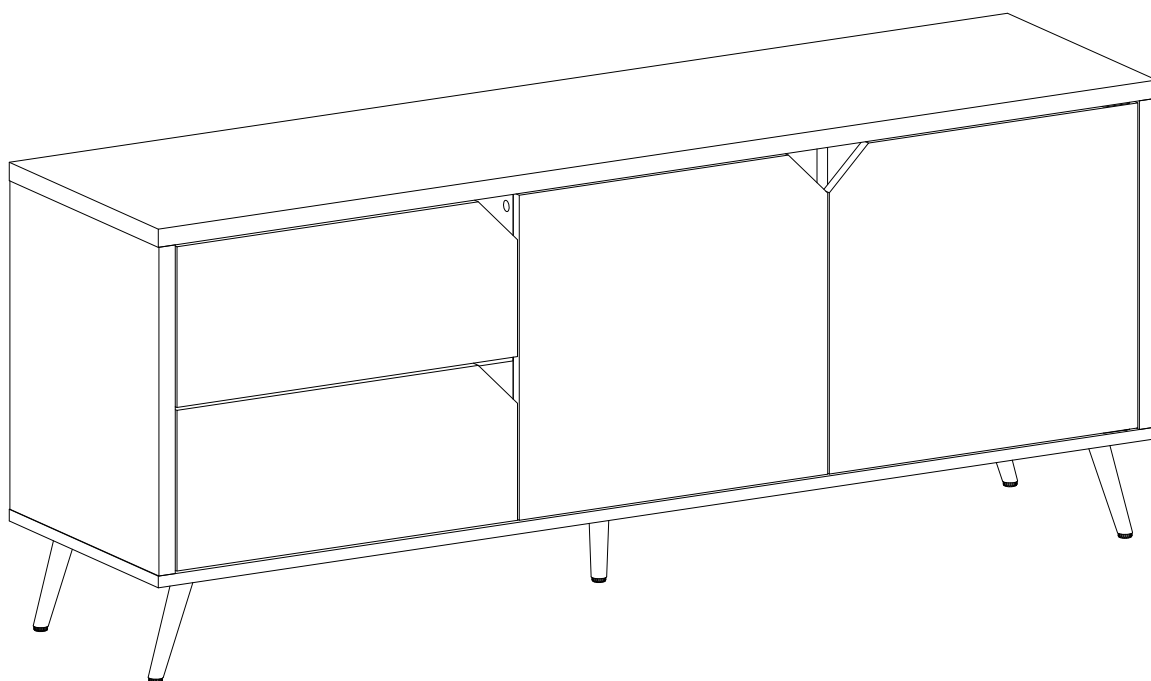

## Final Assembly