

**Three Seats Sofa**

# TOOLS REQUIRED



ALLEN WRENCH  
(PROVIDED)



300 LBS  
PER SEAT



2 PERSON  
ASSEMBLY



APPROXIMATELY  
15 MIN.  
ASSEMBLY

## INCLUDED PARTS

A M6x30mm SCREW



14 PCS

B M6 WASHER



14 PCS

1 THRESEATS SOFA  
BACKREST



1 PC

2 THRESEATS SOFA  
SEAT



1 PC

3R RIGHT ARM



1 PC

3L LEFT ARM



1 PC

4 THRESEATS SOFA  
FRONT



1 PC

5 SEAT CUSHION



3 PCS

6 BACK CUSHION



3 PCS

Use tools to attach hardware in the following way:

2

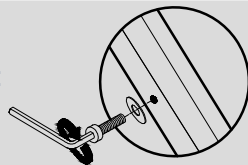

# PRODUCT ASSEMBLY - THREESESTS SOFA

1

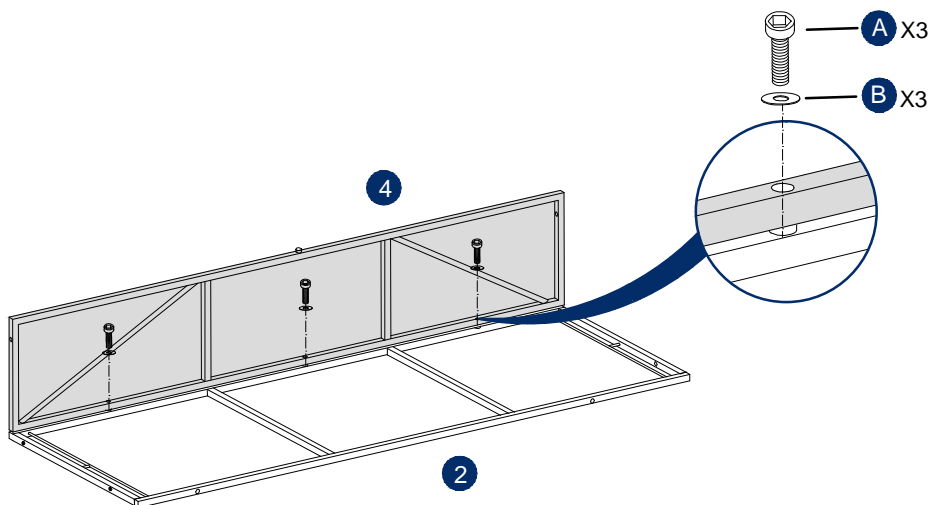

2

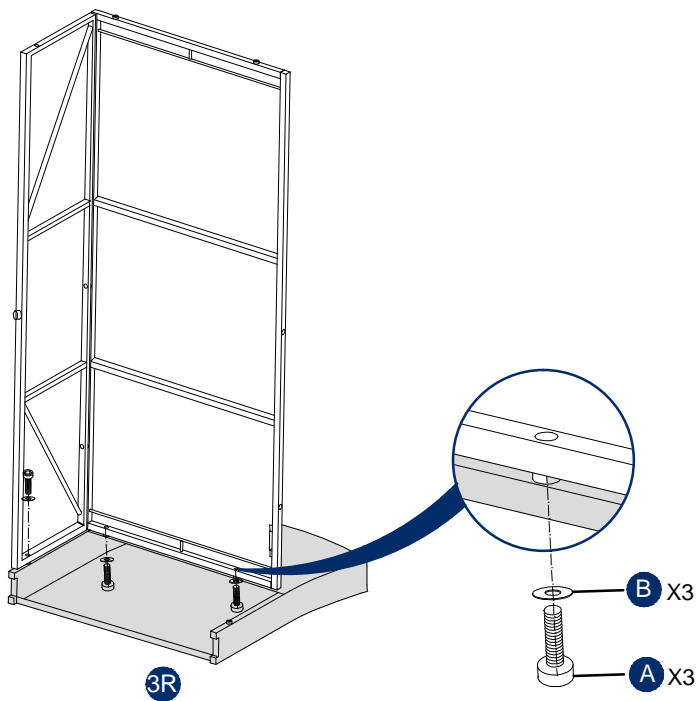

3

# PRODUCT ASSEMBLY - THREESETS SOFA

3

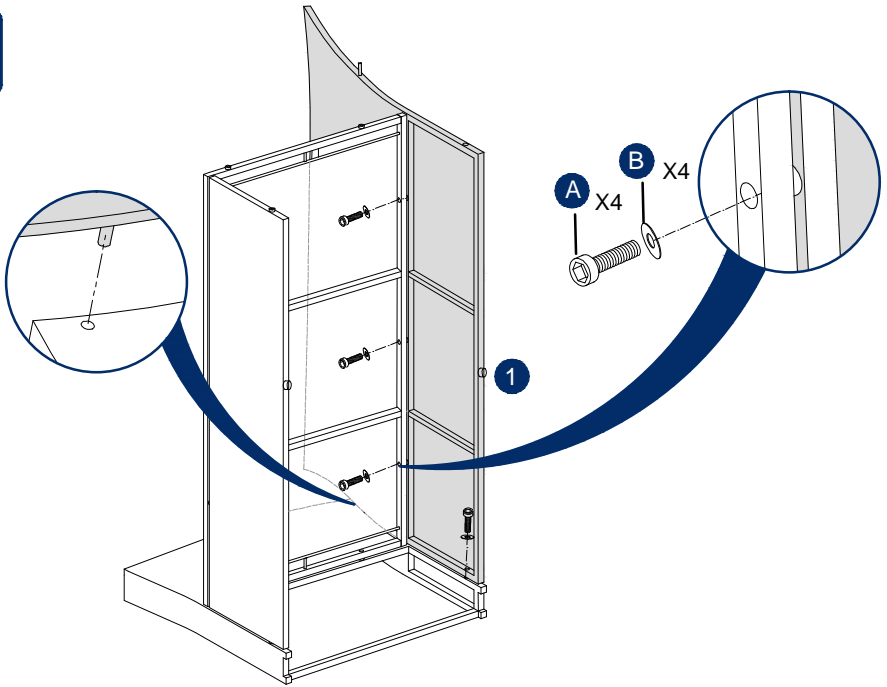

4

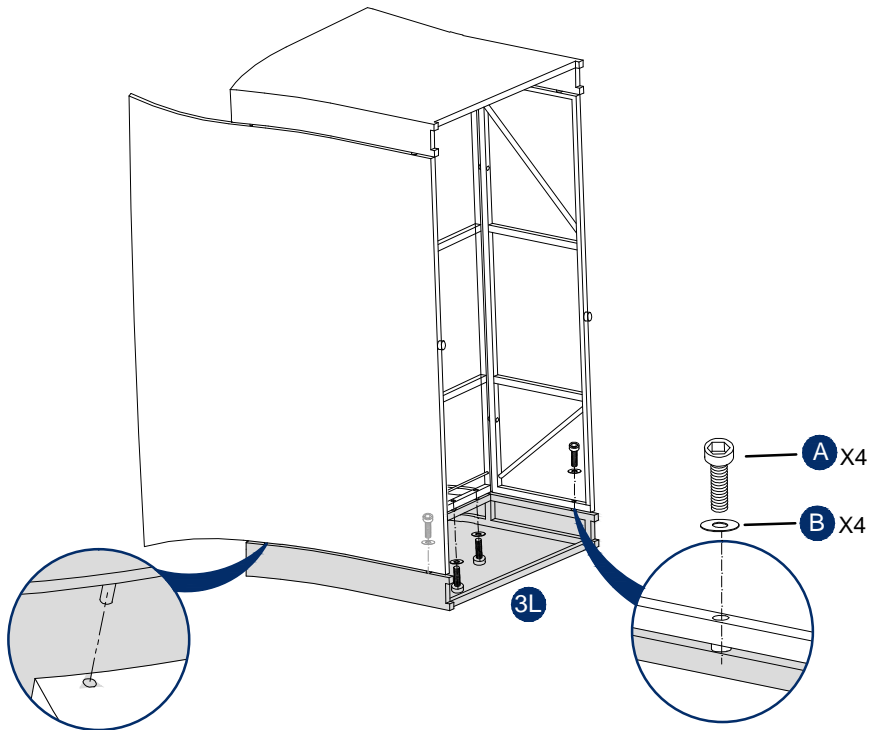

4

## PRODUCT ASSEMBLY - CUSHIONS

NOTE: Cushions are not waterproof; they are water resistant and can only withstand light rain. Do not leave cushions out in inclement weather

5

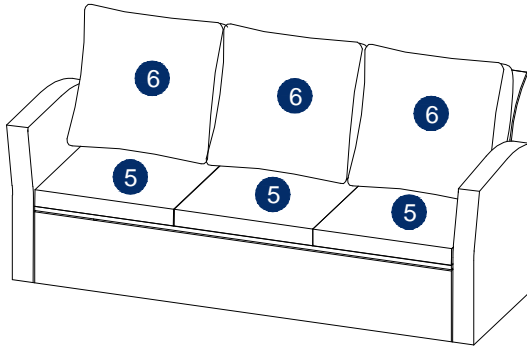



## INSTALLATION NOTICES

### 1. Pre-Assembly Preparation:

Check for all components and tools needed. Choose a suitable location and prepare the area.

### 2. Read the Instruction Manual:

Review the manual thoroughly, focusing on diagrams and warnings.

### 3. Organize Parts and Tools:

Lay out parts and hardware systematically. Ensure you have the necessary tools.

### 4. Step-by-Step Assembly:

Follow the manual's instructions carefully. Tighten parts securely as required.

### 5. Safety Considerations:

Be cautious and seek assistance if needed. Adhere to weight and load restrictions.



## MATERIALS AND CARE GUIDE

### • Aluminum Furniture:

1. Clean aluminum frames with a soft cloth and mild soapy water.
2. Avoid abrasive cleaners or brushes to prevent surface scratches.
3. Apply automotive wax to preserve shine and protect against oxidation.
4. During extreme weather, consider covering or storing indoors.

### • Cushions:

1. Brush off dirt and debris from cushions regularly with a soft-bristle brush.
2. Spot clean stains promptly with a mild detergent and water solution.
3. The cushion covers are zippered design and machine washable.
4. Ensure cushions are fully air dried to prevent mold or mildew growth before using or storing.

**Need assistance or have questions?  
Our dedicated customer support team is ready to help.**

## **Warranty**

### **Warranty Coverage:**

- Covers defects in materials and workmanship.
- Valid for 1 year from the date of purchase.
- Includes repair or replacement of defective parts or products.

### **Warranty Exclusions:**

- Does not cover improper assembly, installation, or misuse.
- Excludes normal wear and tear, acts of nature, unauthorized modifications, and unauthorized transfers.

### **Warranty Claim Procedure:**

- Contact our customer service with proof of purchase.
- Provide details and evidence of the defect.
- Our team will assess and guide you through the repair or replacement process.

### **Limitation of Liability:**

- Our liability is limited to repair or replacement.
- We are not liable for incidental, consequential, or indirect damages.

## **Return Policy**

Thank you for choosing us. Our return policy aims to provide a hassle-free experience for returning products purchased from us. Please review the following guidelines:

### **Eligibility:**

Products must be returned in their original, unused, and undamaged condition, including the packaging. The errors qualify for free return shipping and a full 100% refund. In cases where damage or use is caused by the customer, return shipping costs are the customer's responsibility. Customer-caused damage or used items are eligible for a partial refund based on the extent of the damage.

### **Return Timeframe:**

Returns must be initiated within 30 calendar days from the delivery date.

### **Return Process:**

Log in to your account, select the order from "Your Orders," and contact our customer service for a prepaid return label. Attach the label securely to the package and drop it off at a designated carrier location or schedule a pickup.

### **Refund Process:**

Once the returned product is received and inspected, a refund will be issued to the original payment method. Refunds are typically processed within 3-5 business days.