

Assembly Instructions

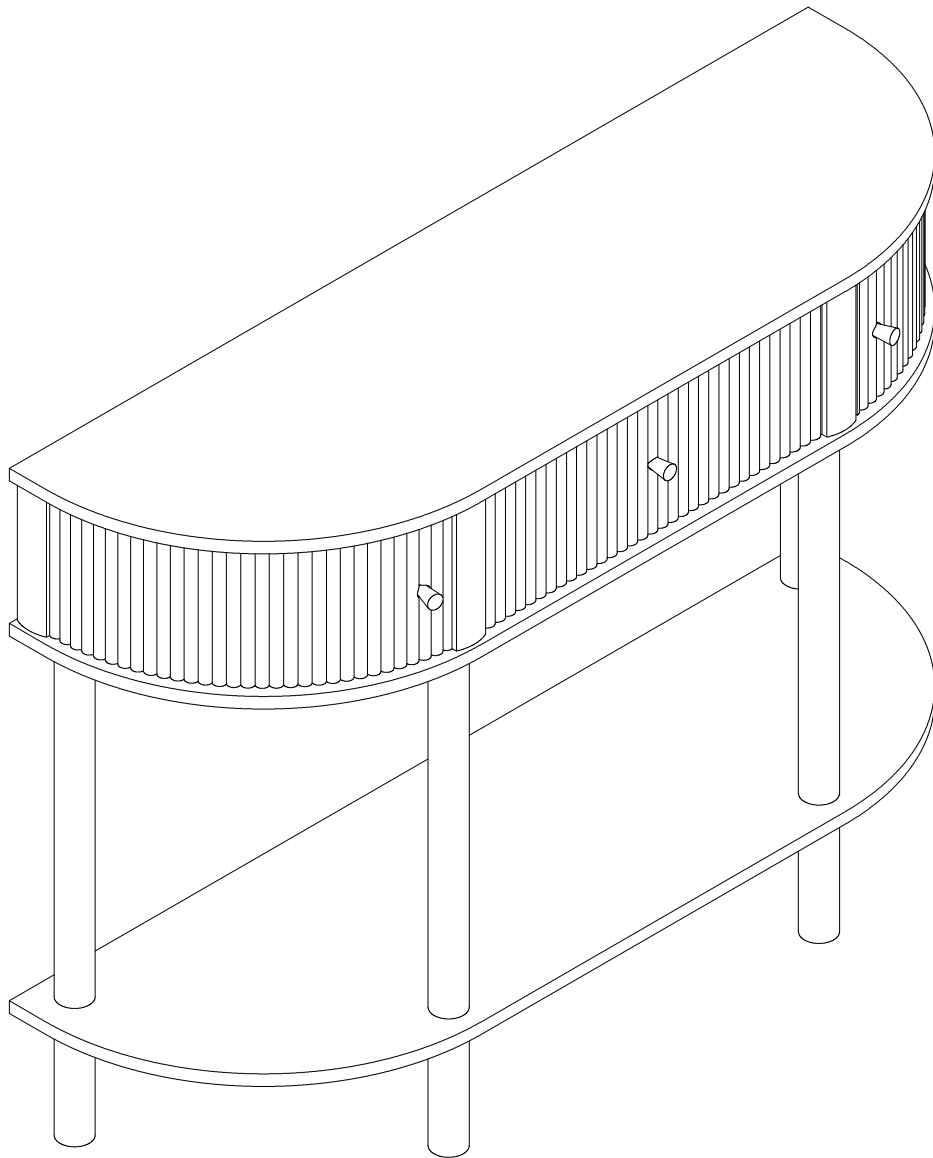

Before Assembly

Tips Before Your Start:

- Remove all wrapping material, including staples & packing straps before you start to assemble.
- DO NOT tighten all screws and bolts until the assembly is completely assembled.
- Keep all hardware parts out of reach of children.

QUICKFIT

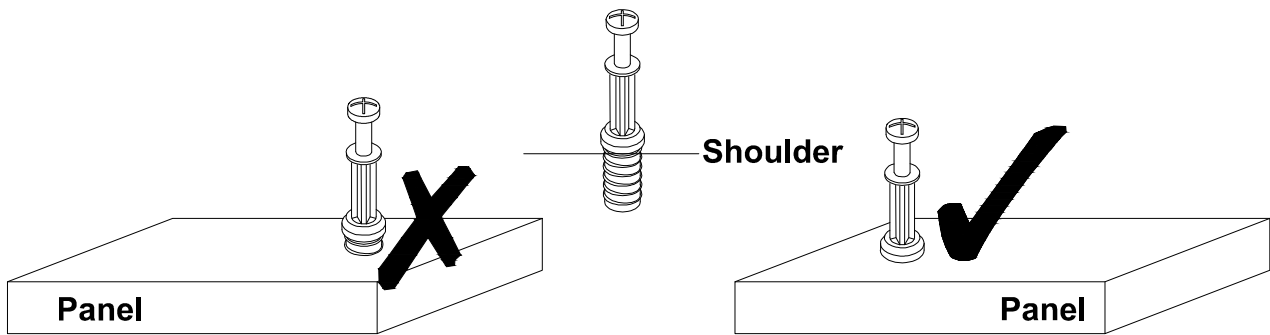

Tighten quickfit until shoulder is flush with panel. Do not overtighten or undertighten.

CAM LOCK

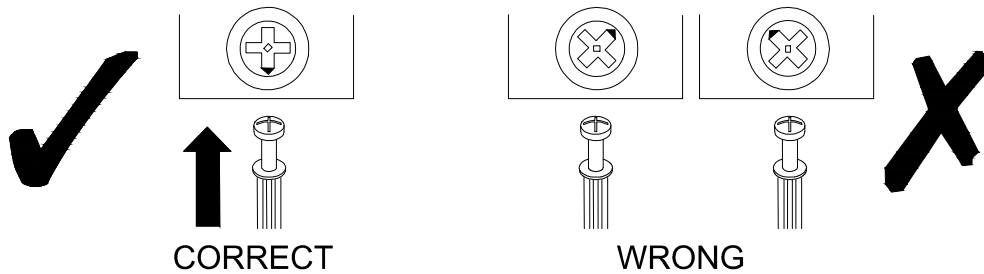

When fitting a cam lock, ensure the starting position is correct before inserting the connecting QUI CKFIT

Quickfit head should be in the centre of the cam lock when the two panels are joined.

Cam lock should be inserted before quickfit.

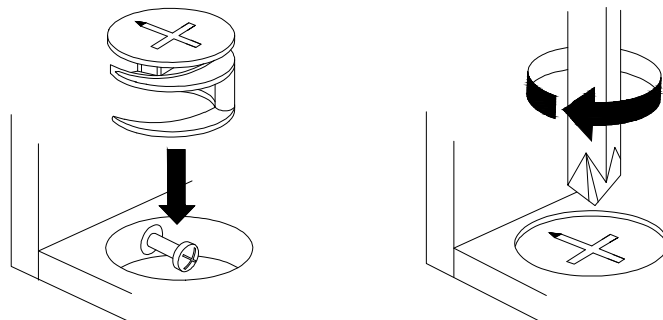

Turn cam lock clockwise to tighten.

Before Assembly

Tips Before Your Start

How to separate the drawer slider:

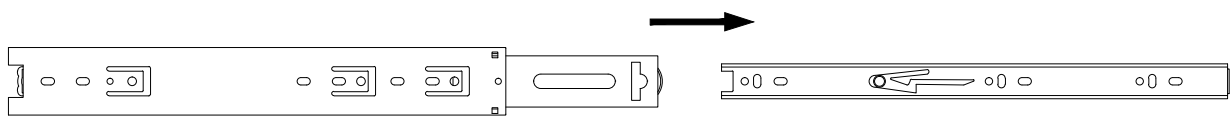
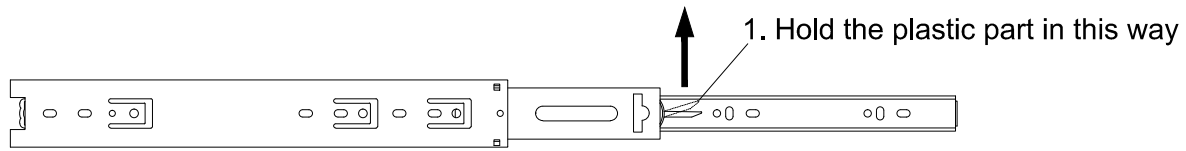

2. Pull out the inner slider for drawer box fixing

Drawer Front Alignment

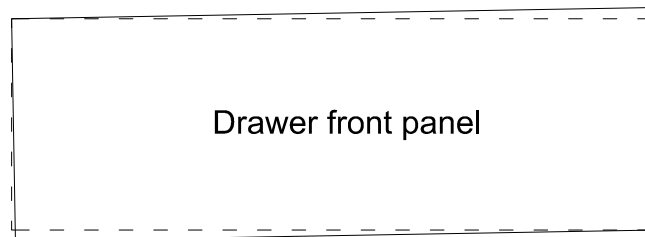



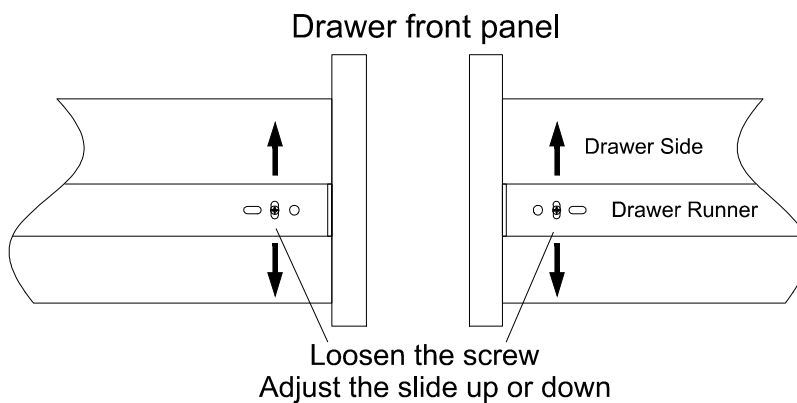







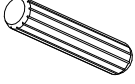
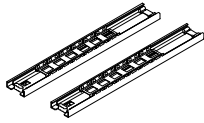

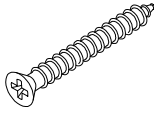
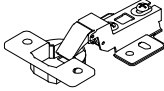
If the drawer front panel is NOT level after being assembled, then...

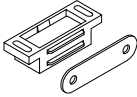
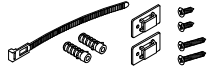

Loosen the screws on the left and right hand side, then adjust the drawer slide up or down, until the drawer fronts are even/level, then tighten the screws.

Part List

| | | | |
|---|--|--|---|
| <p>No. A Quantity:23 Pcs Cam Lock Dowel 8*28mm</p>  | <p>No. B Quantity:23 Pcs Cam φ15*11</p>  | <p>No. C Quantity:23 Pcs Sticker Ø20</p>  | <p>No. D Quantity:16 Pcs Dowel 8*30mm</p>  |
| <p>No. E Quantity:1 Sets Drawer Slider 10"</p>  | <p>No. F Quantity:8 Pcs Screw 3.5*12mm</p>  | <p>No. G Quantity:12 Pcs Screw 4*30mm</p>  | <p>No. H Quantity:4 Pcs Hinge</p>  |
| <p>No. I Quantity:4 Pcs Foot Pad Ø20×3</p>  | <p>No. J Quantity:3 Pcs Screw M4*18mm</p>  | <p>No. K Quantity:3 Pcs Handle</p>  | <p>No. L Quantity:2 Sets Magnetic Door Catcher</p>  |
| <p>No. M Quantity:1 Sets Anti-falling Parts</p>  | <p>No. N Quantity:7 Pcs Screw M6*40mm</p>  | <p>No. O Quantity:1 Pcs Allen Key 4#</p>  | <p>No. P Quantity:32 Pcs Screw 3.5*14mm</p>  |
| <p>No. Q Quantity:4 Pcs Cam φ15*9</p>  | | | |

Product structure

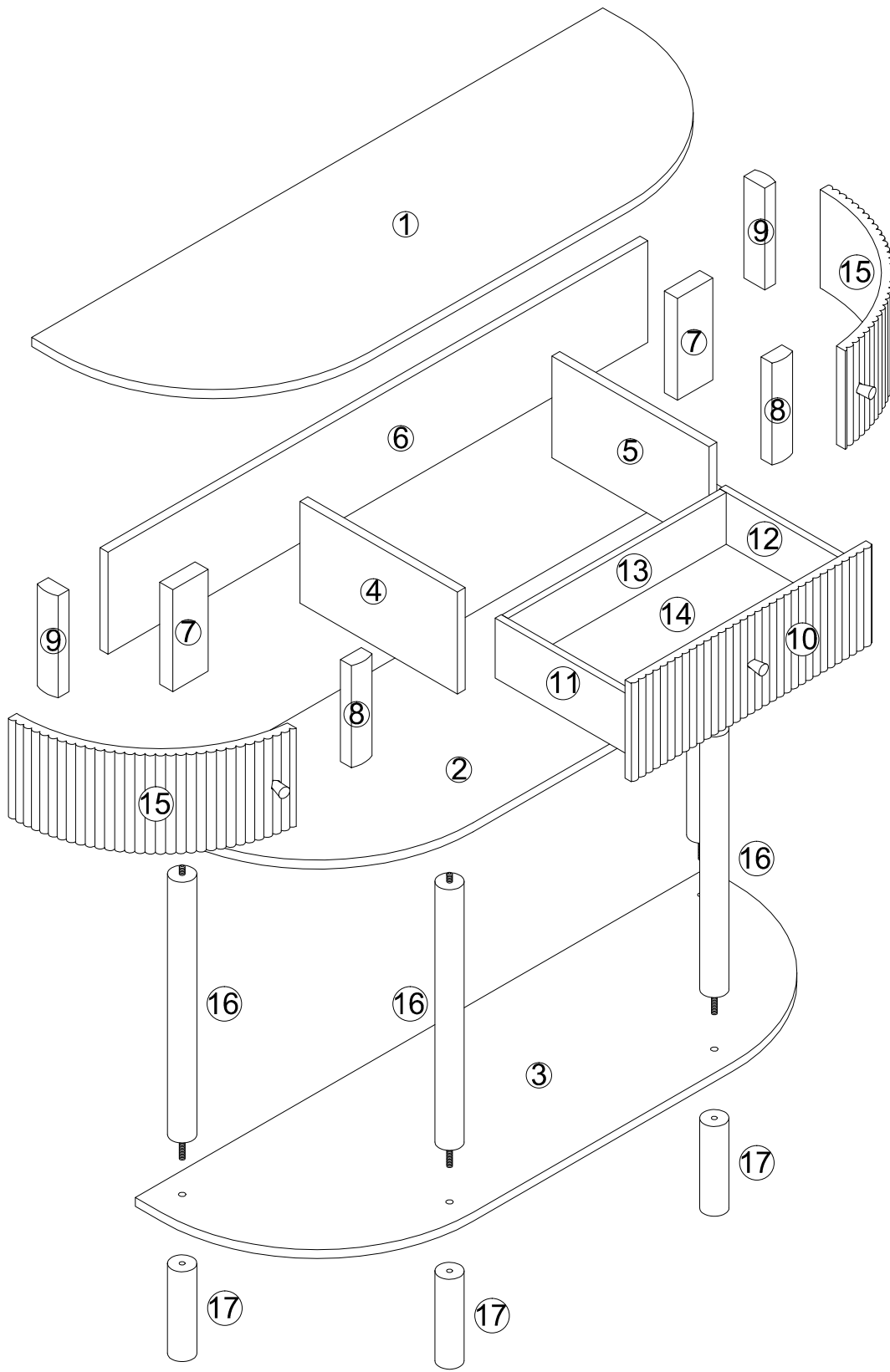

STEP 1

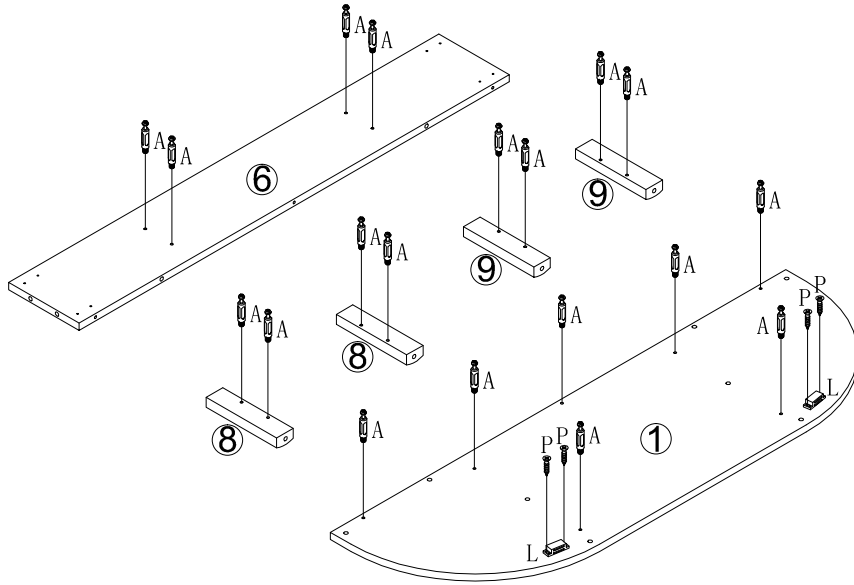

No. A
Quantity: 19 Pcs
8*28 mm



No. P
Quantity: 4 Pcs
3.5*14mm



No. L
Quantity: 2 Pcs

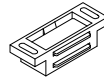

STEP 2



The first screw hole should corresponded with the board location hole

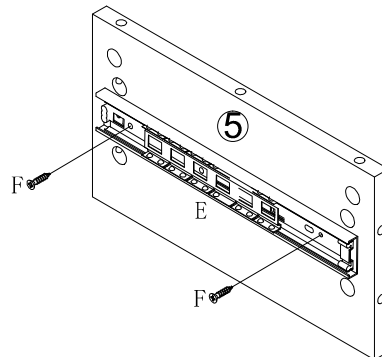
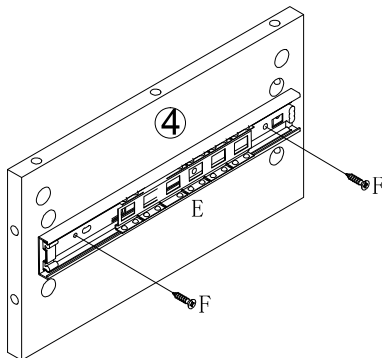

No. E
Quantity: 1 Sets
10"

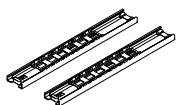

No. F
Quantity: 4 Pcs
M3.5*12mm



STEP 3

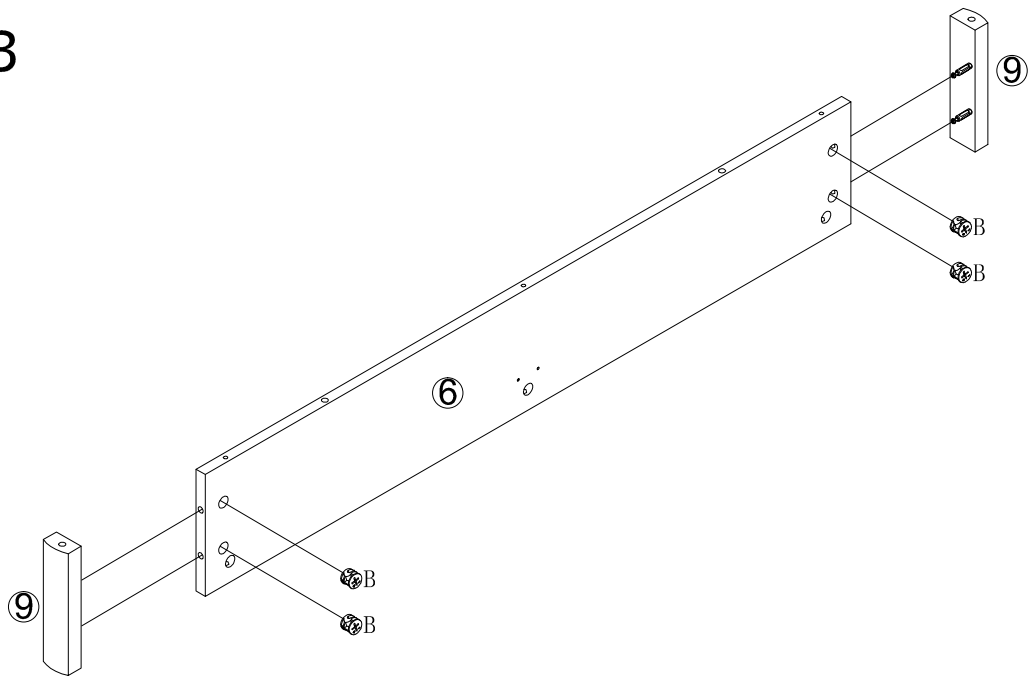

No. B
Quantity: 4 Pcs
Ø15*11



STEP 4

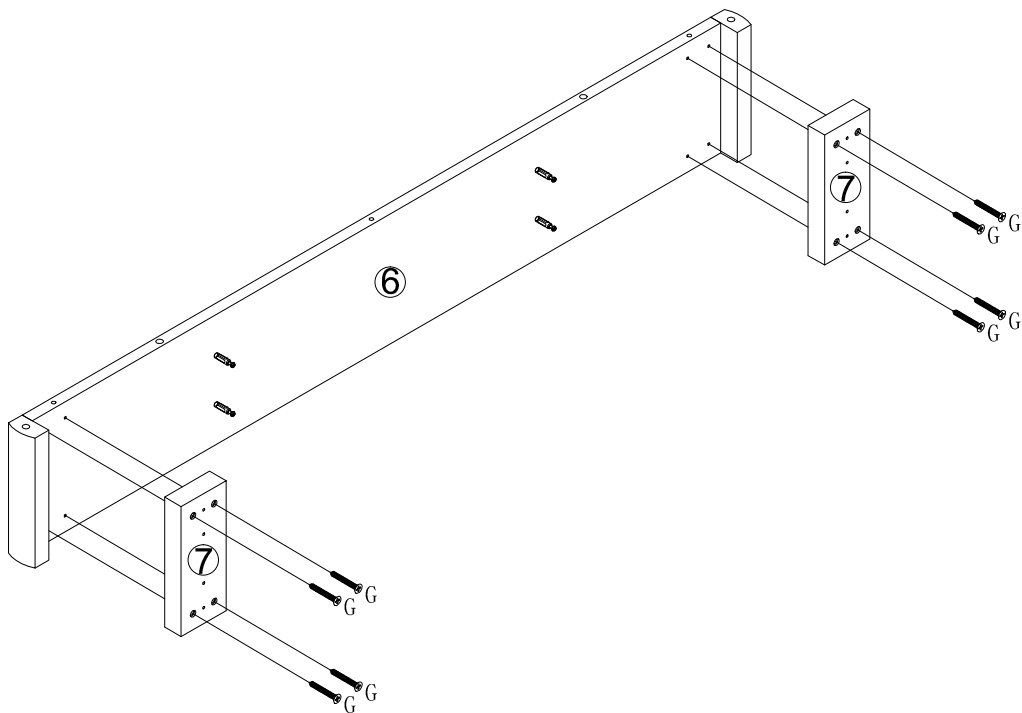

No. G
Quantity: 8 Pcs
4*30mm



STEP 5

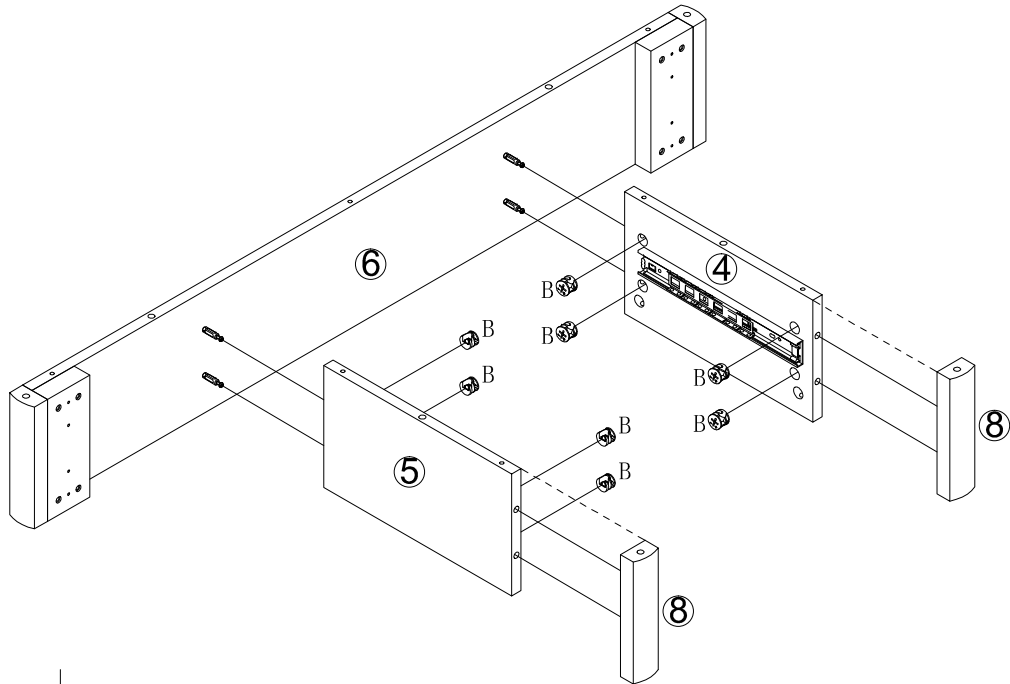

No. B
Quantity: 8 Pcs
Ø15*11



Note: Cam Lock Dowel Holes all directions down, uniform direction.

STEP 6

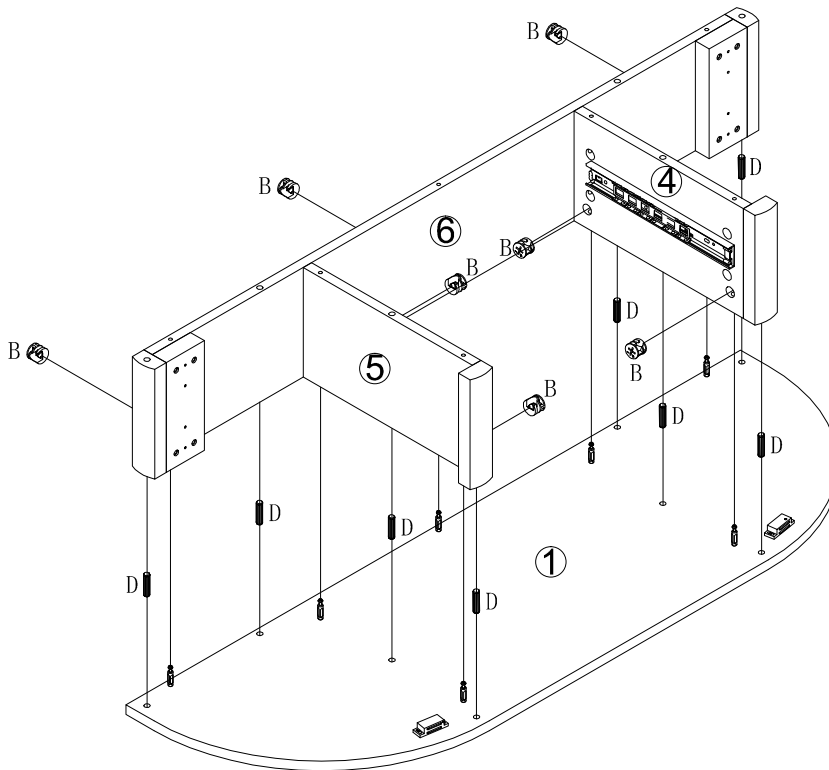

No. B
Quantity: 7 Pcs
Ø15*11



No. D
Quantity: 8 Pcs
8*30mm

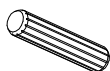

STEP 7

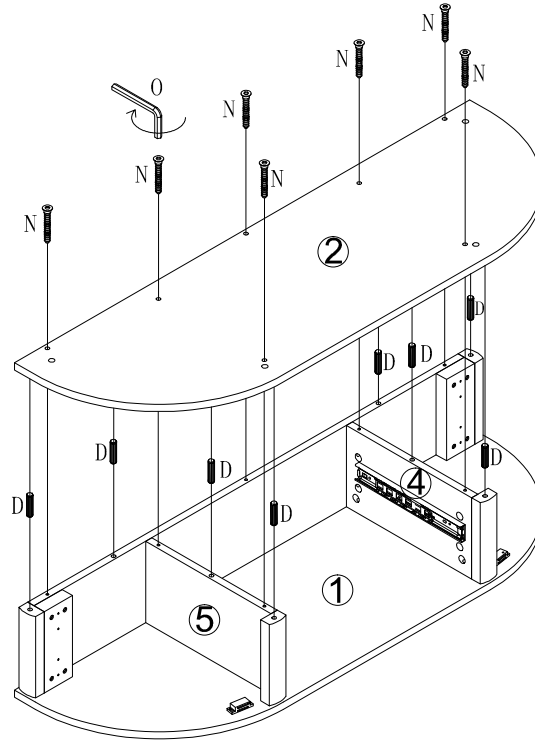

No. D
Quantity: 8 Pcs
8*30mm

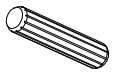

No. N
Quantity: 7 Pcs
M6*40mm



No. O
Quantity: 1 Pcs
4#



STEP 8

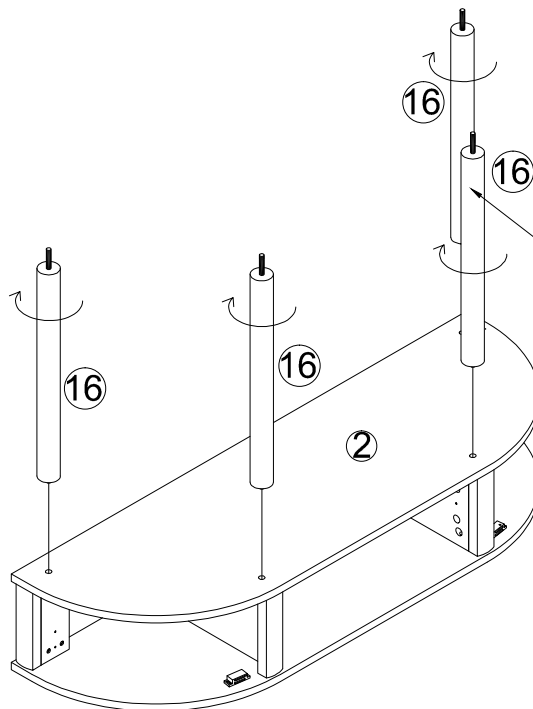

Note: The long screw rod should face upwards.

STEP 9

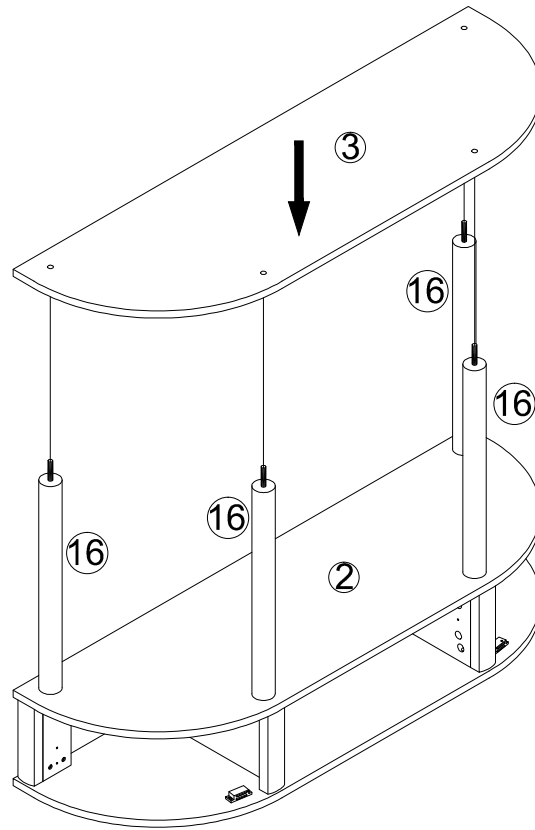

STEP 10

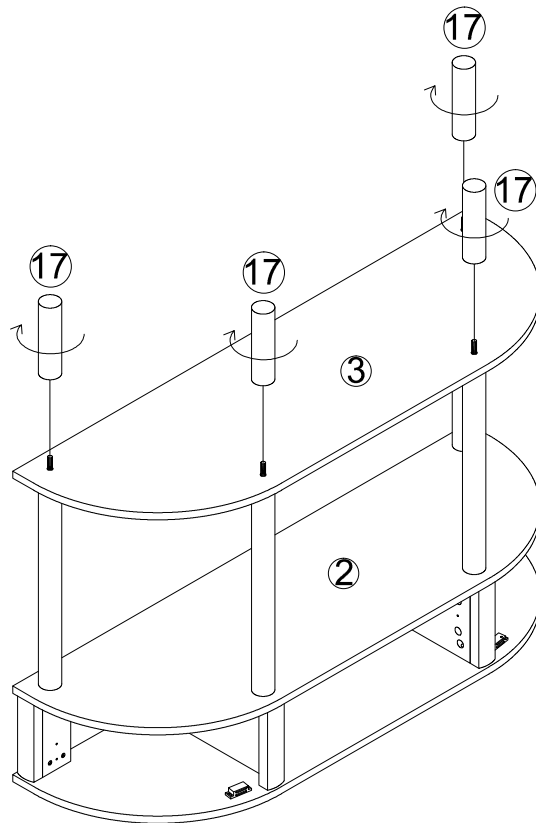

STEP 11

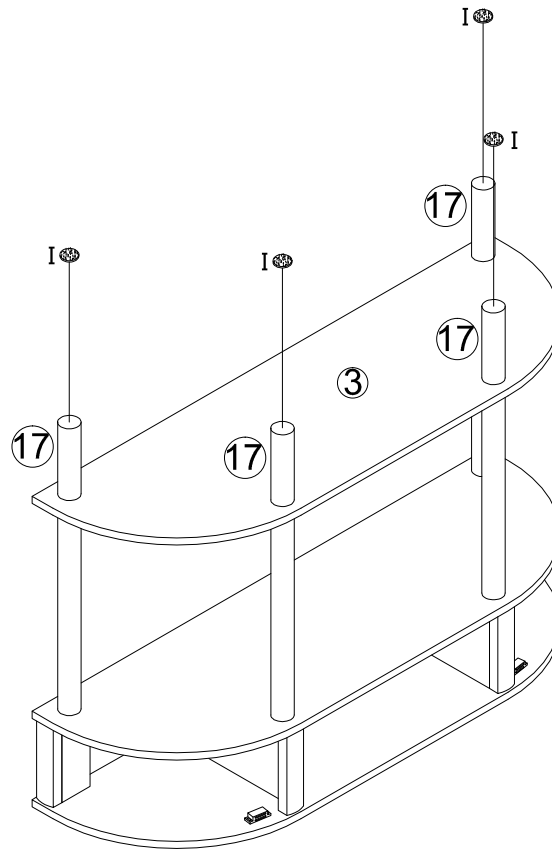

No. I
Quantity: 4 Pcs
Ø20



STEP 12

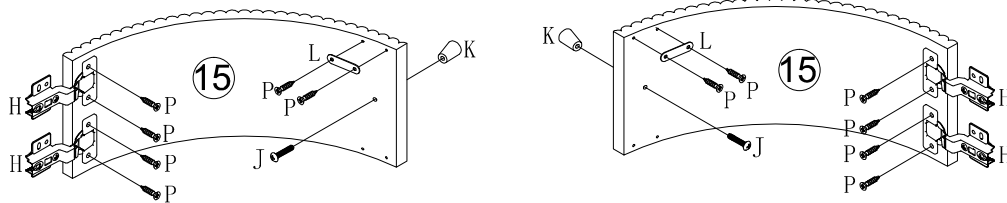

No. P
Quantity: 12 Pcs
3.5*14mm



No. H
Quantity: 4 Pcs

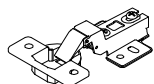

No. J
Quantity: 2 Pcs
M4*18mm



No. K
Quantity: 2 Pcs



No. L
Quantity: 2 Pcs

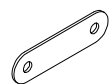

STEP 13

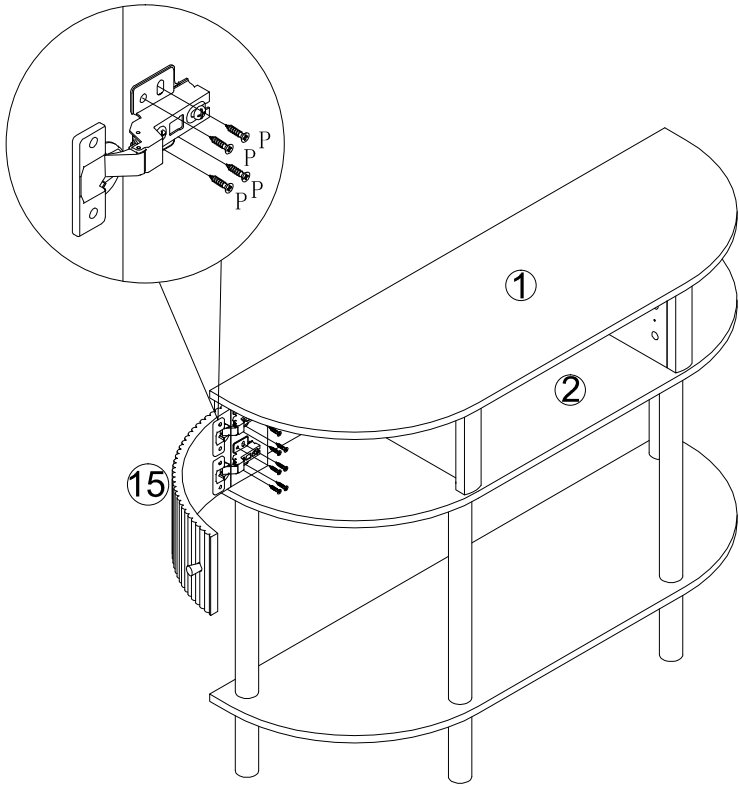
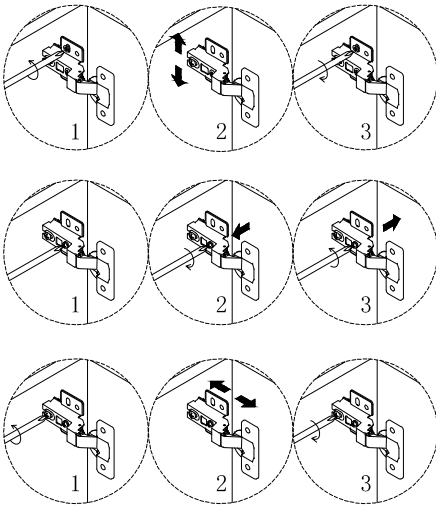

No. P
Quantity: 8 Pcs
3.5*14mm



STEP 14

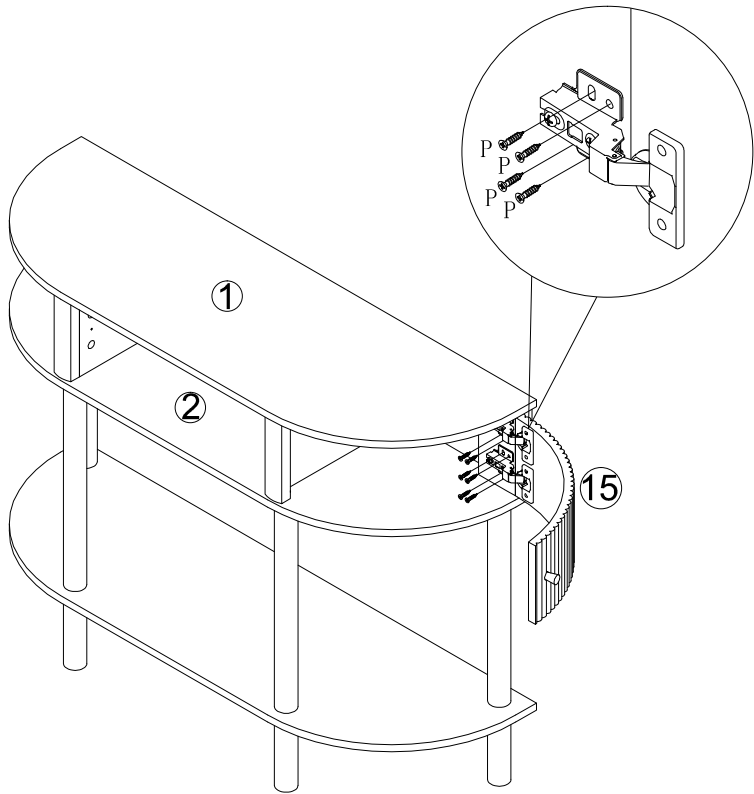
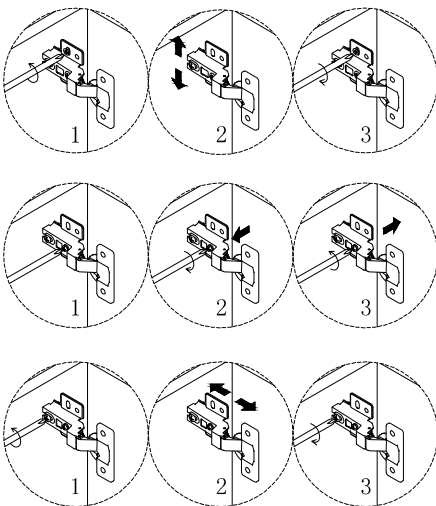

No. P
Quantity: 8 Pcs
3.5*14mm



STEP 15

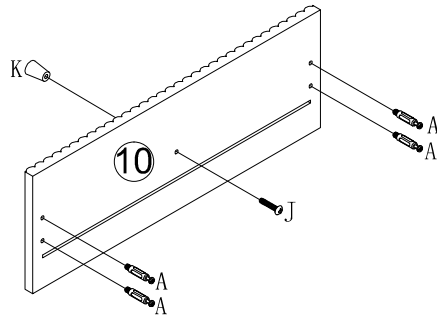

No. A
Quantity: 4 Pcs
8*28 mm



No. J
Quantity: 1 Pcs
M4*18mm



No. K
Quantity: 1 Pcs



STEP 16

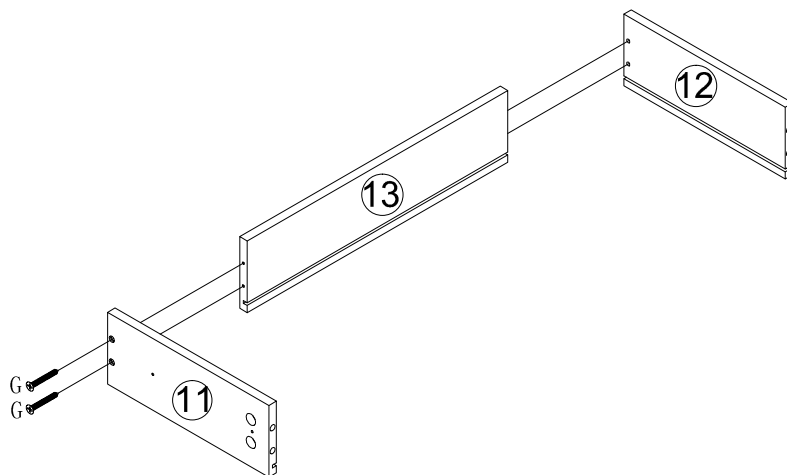

No. G
Quantity: 4 Pcs
4*30mm

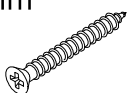

STEP 17

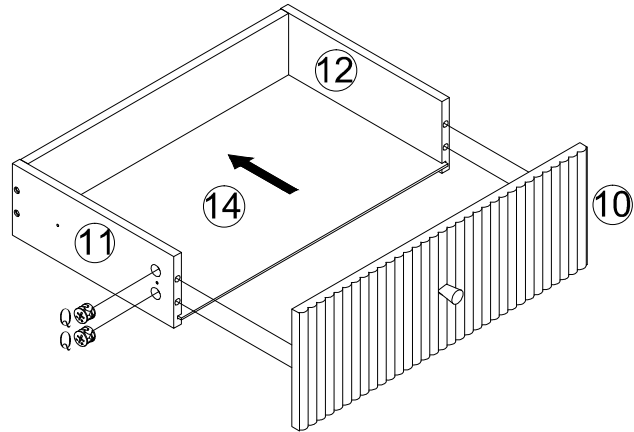

No. Q
Quantity: 4 Pcs
Ø15*9



STEP 18



The first screw hole should corresponded with the board location hole

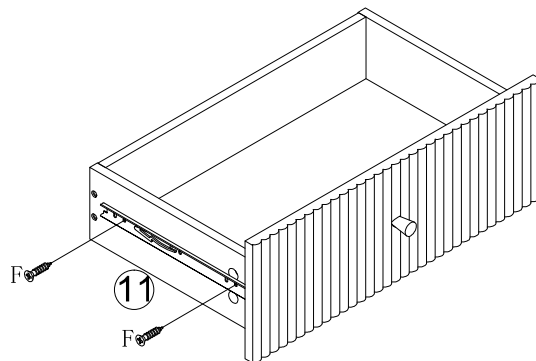

No. E
Quantity: 1 Sets
10"



No. F
Quantity: 4 Pcs
M3.5*12mm



STEP 19

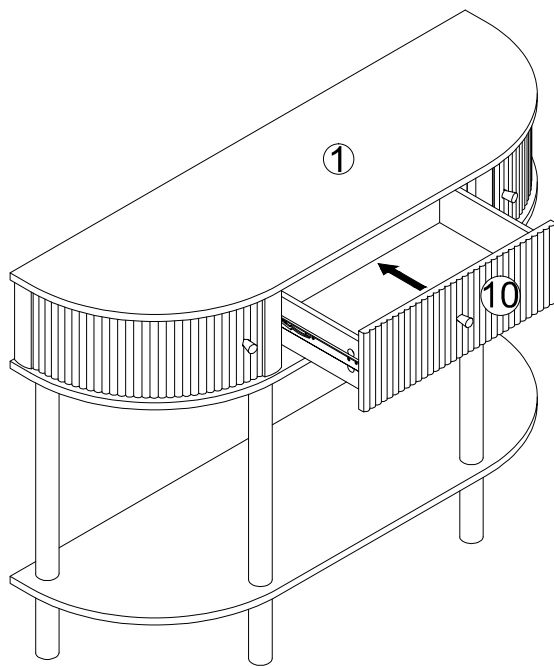

STEP 20

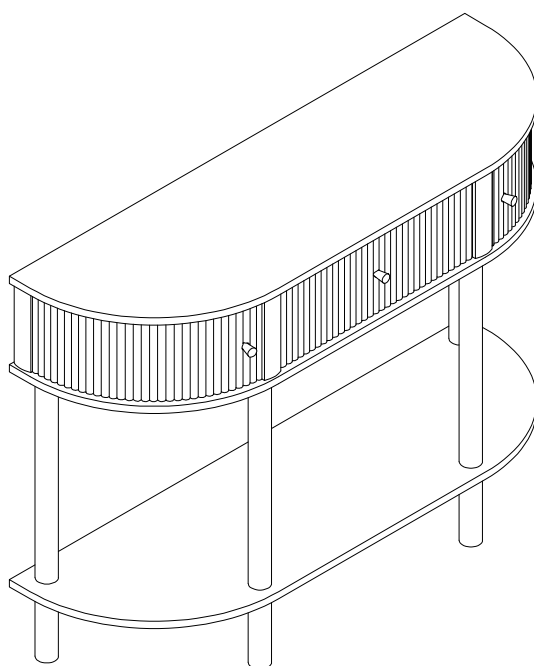

STEP 21

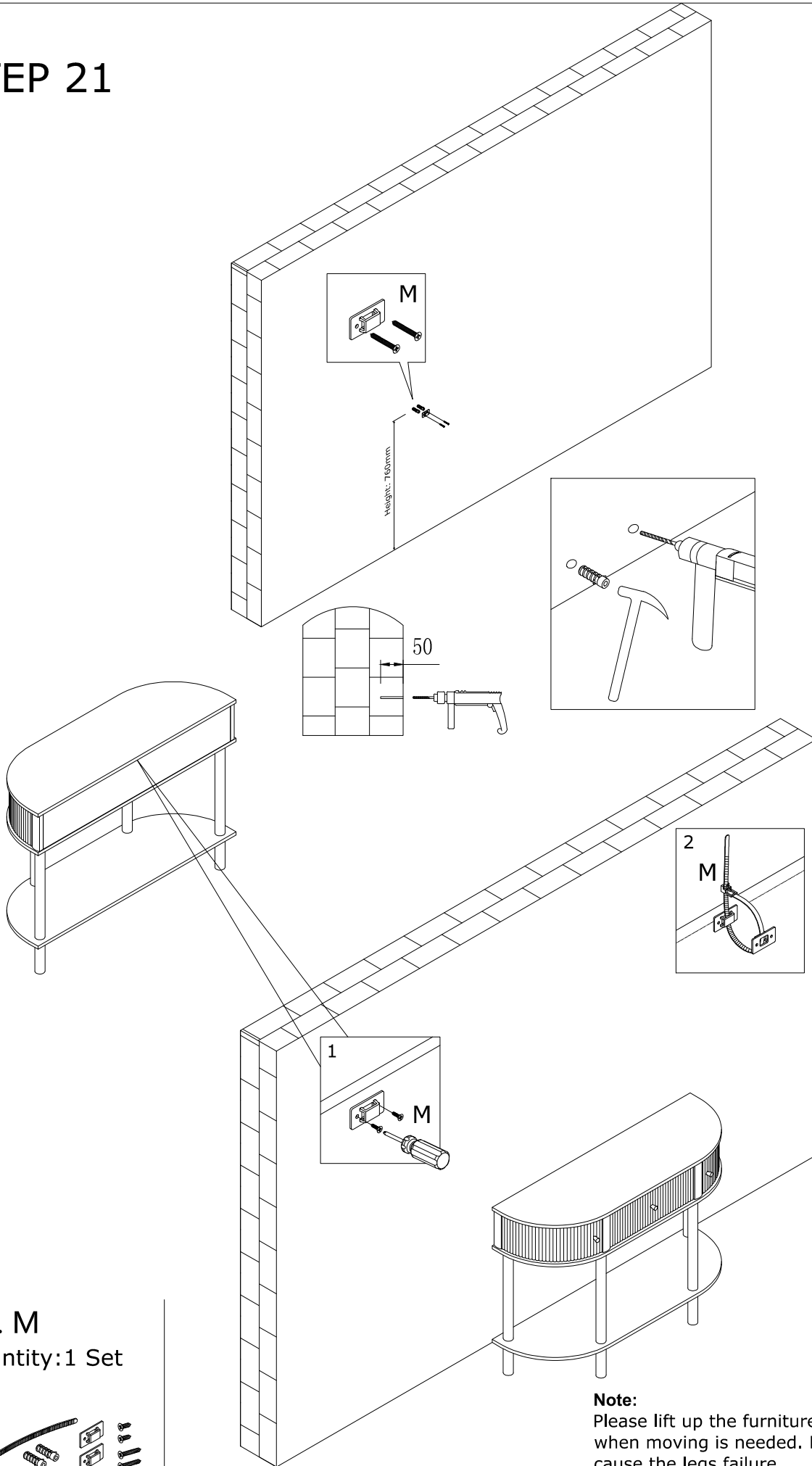

No. M
Quantity: 1 Set

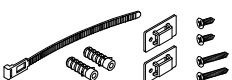

Note:
Please lift up the furniture by two people when moving is needed. Dragging may cause the legs failure.