

Assembly Instructions

Chair

Caution: You must read this before you proceed

Please look underneath the foldable seat panel for hardware packs

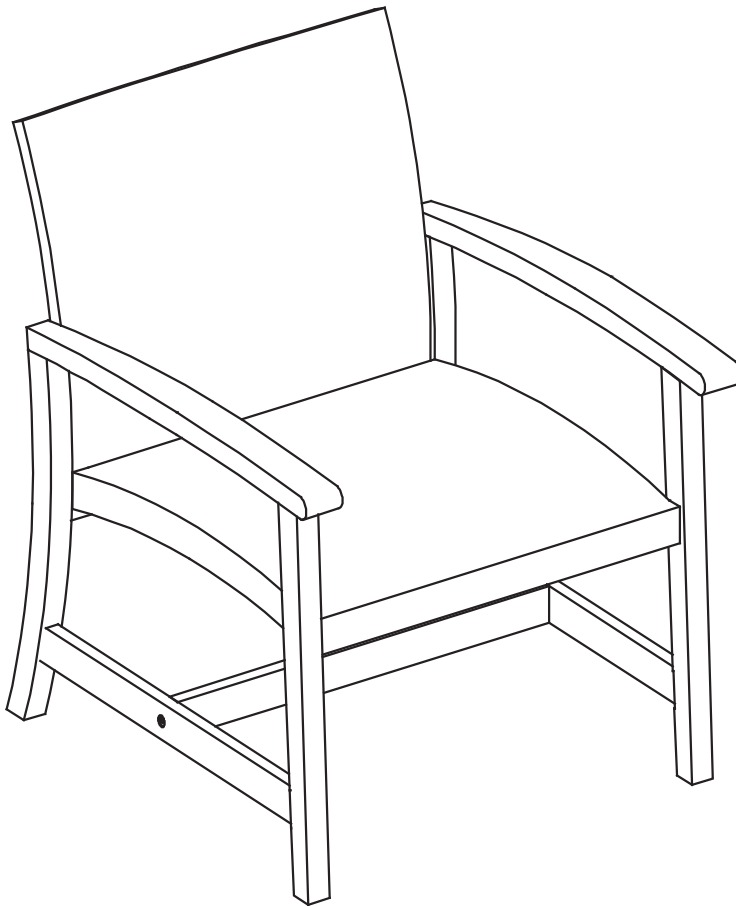



CAUTION: This Chair is NOT a TOY.

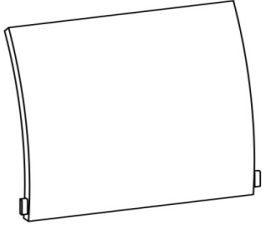

Keep your child / children at bay during the assembly process of assembly.

For turning the Chair and to prevent damage to the Chair, 02 persons may be needed to execute this action

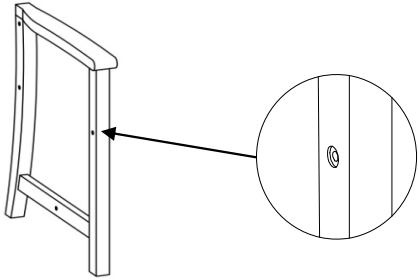
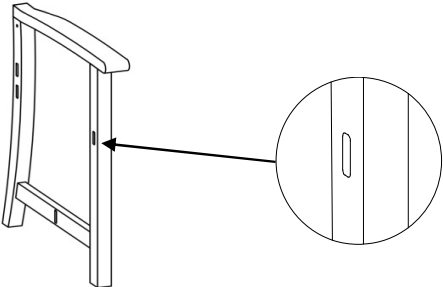
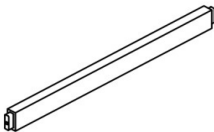
Parts List

Label	Picture	Description	QTY
A		Back Panel	1
B		Seat Panel	1
C		Left Leg Panel	1
D		Right Leg Panel	1
E		Leg Support Bar	1

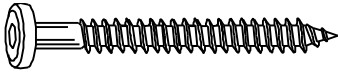
Hardware

Label	Picture	Description	QTY
①		Screw (M7x70mm)	7
②		Bolt (M8x55mm)	3
③		Allen Key	2

Assembly Preparation

Before Beginning Assembly:

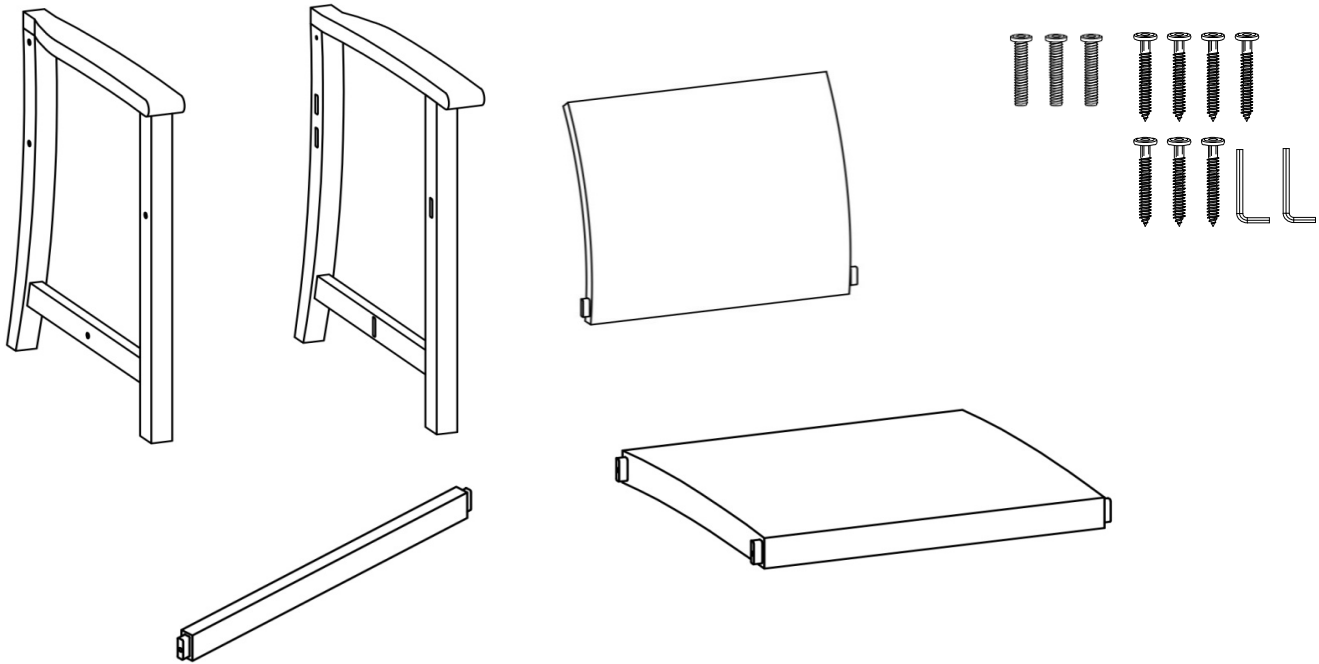

- Read instructions, cover to cover-



- Have 2 adults on hand for assembly-



- Do not assemble on flooring or carpet-



- Assemble on a clean non-marring surface (packing foam)-



- Save all packaging until finished-

Assembly Steps

Overview

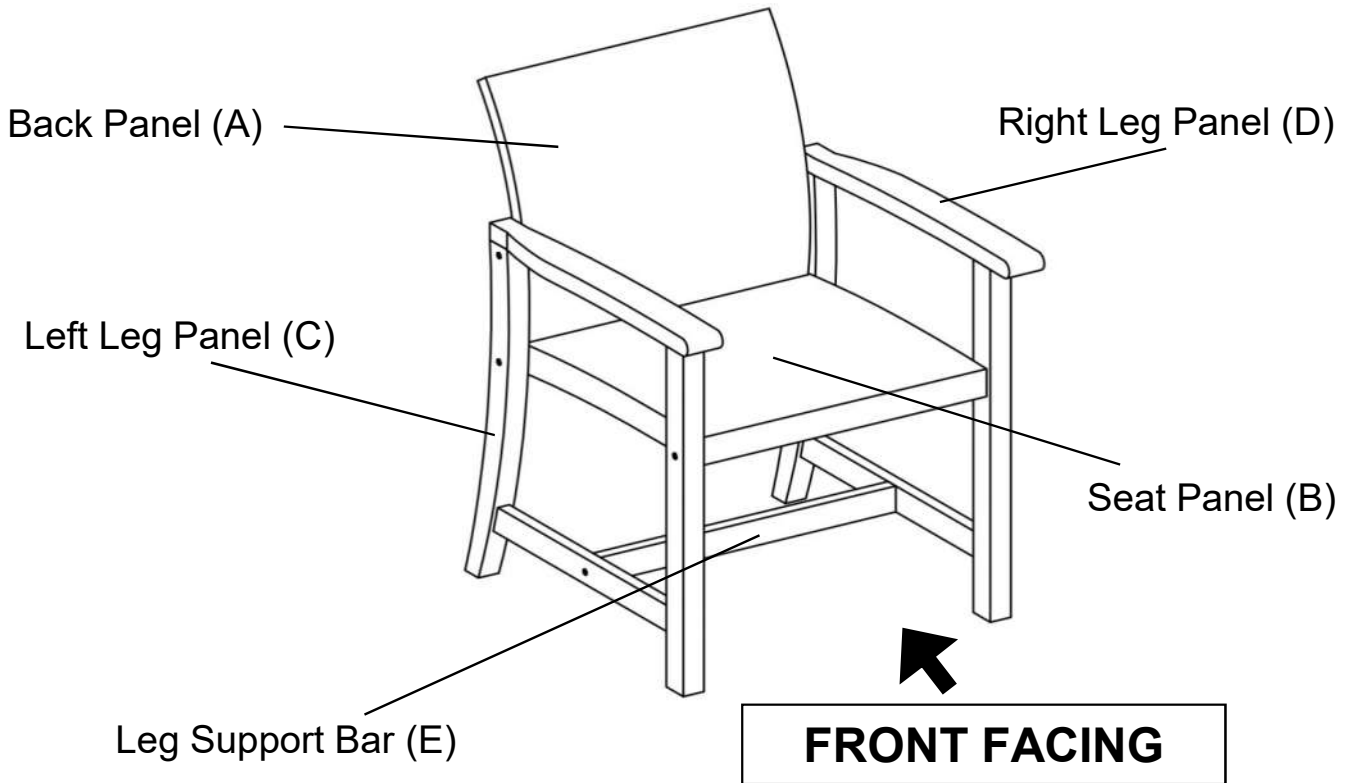

This Chair has multiple parts and may require up to 30 minutes to assemble. To give you an overview of the Chair parts, the above picture is to help you put the various parts into perspective. Please read through the instructions below to familiarise yourself with the parts and steps before assembly.

Step 1

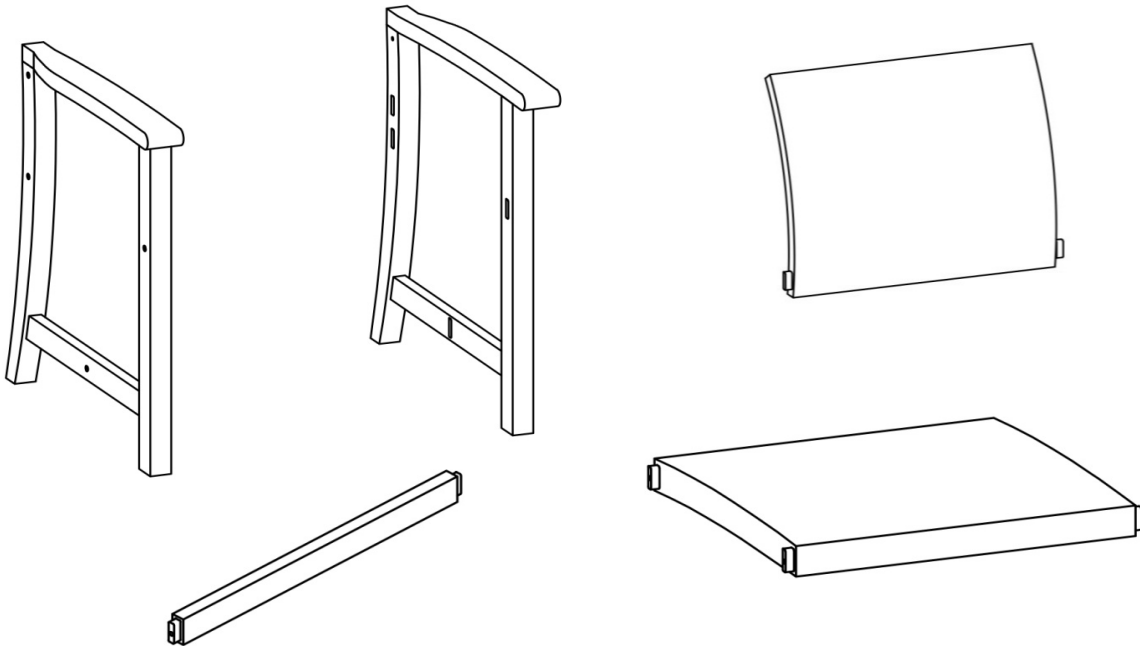

Unpack and place all parts on a clean, non-marring surface.

NOTE: Please arrange and assemble all Parts with same color sticker together

Step 2

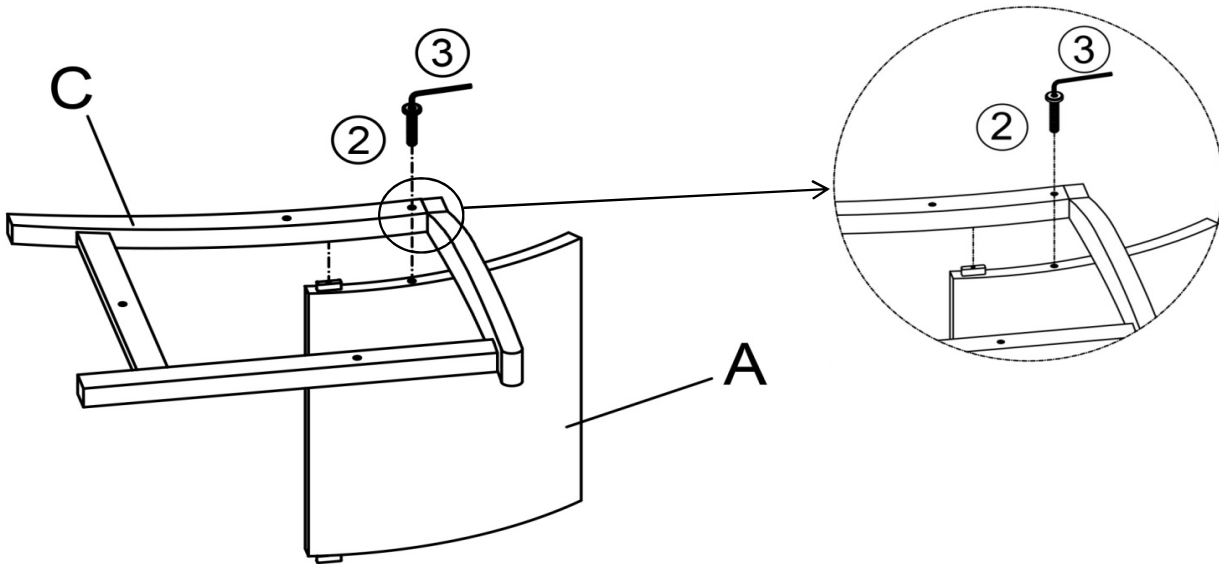

Place Backrest Panel (A) on a clean, non-marring surface. Align the tenon on Backrest Panel to the mortise on Left Leg Panel (C). Then attach Left Leg Panel (C) to Backrest Panel (A) by using Bolt (2) with Allen Key (3). **Do not fully tighten the Bolts.**

Step 3

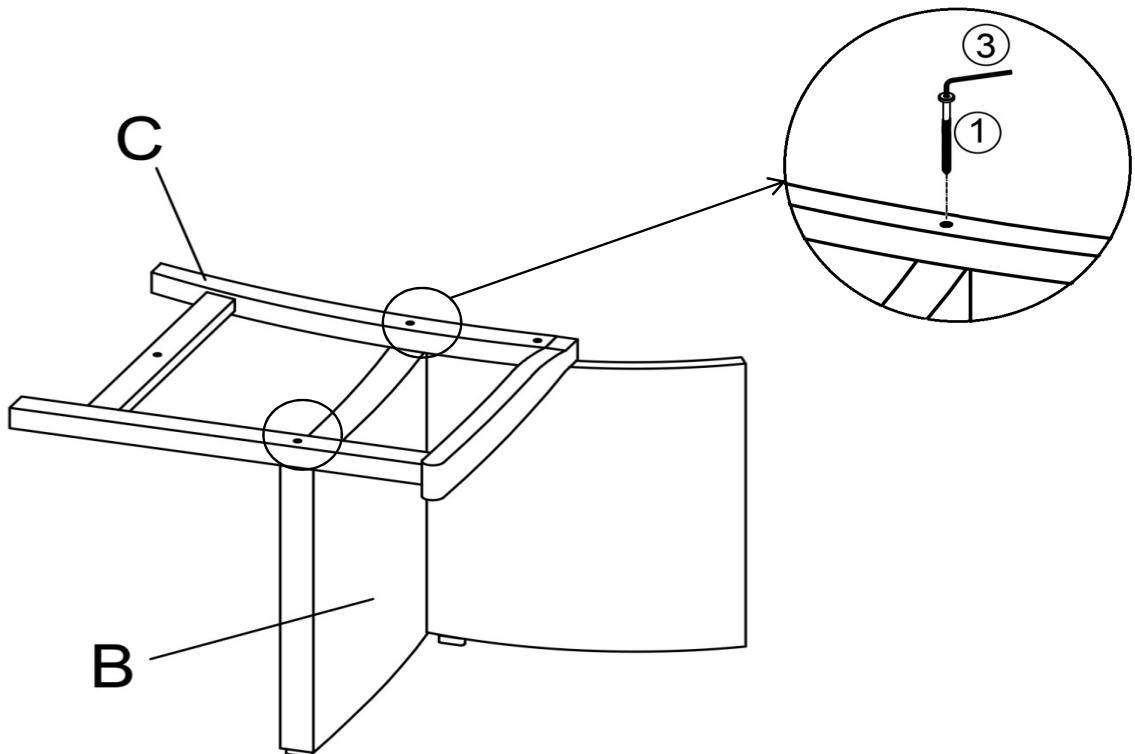

Align the tenon on Seat Panel (B) to the mortise on Left Leg Panel (C). Secure Seat Panel (B) to the Left Leg Panel (C) by using Screws (1) with Allen Key (3). **Do not fully tighten the Screws.**

Step 4

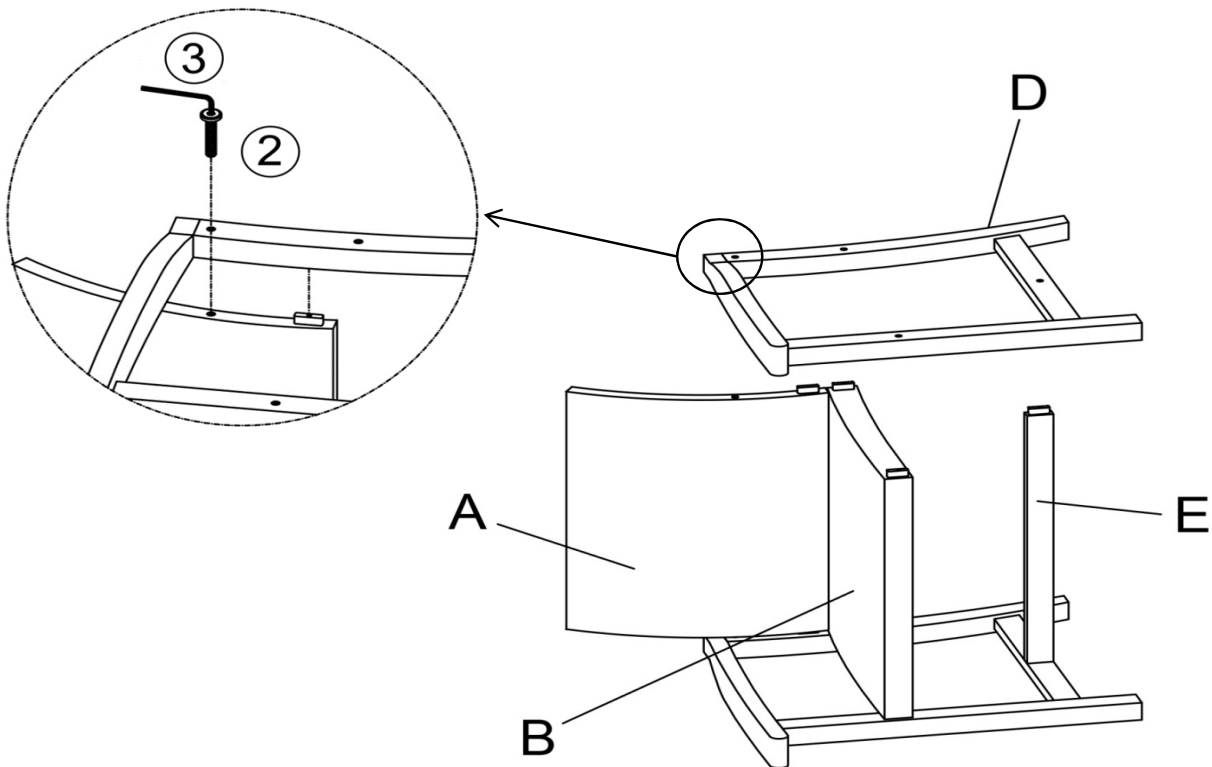

With assistance from your adult partners, turn the Chair into the other side. Insert the tenons on Backrest Panel (A), Seat Panel (B) and Leg Support Bar (E) to the morties on Right Leg Panel (D) as showed in picture above.

Then attach the Right Leg Panel (D) to Backrest Panel (A) by using Bolt (2) with Allen Key (3).

Do not fully tighten the Bolts.

Step 5

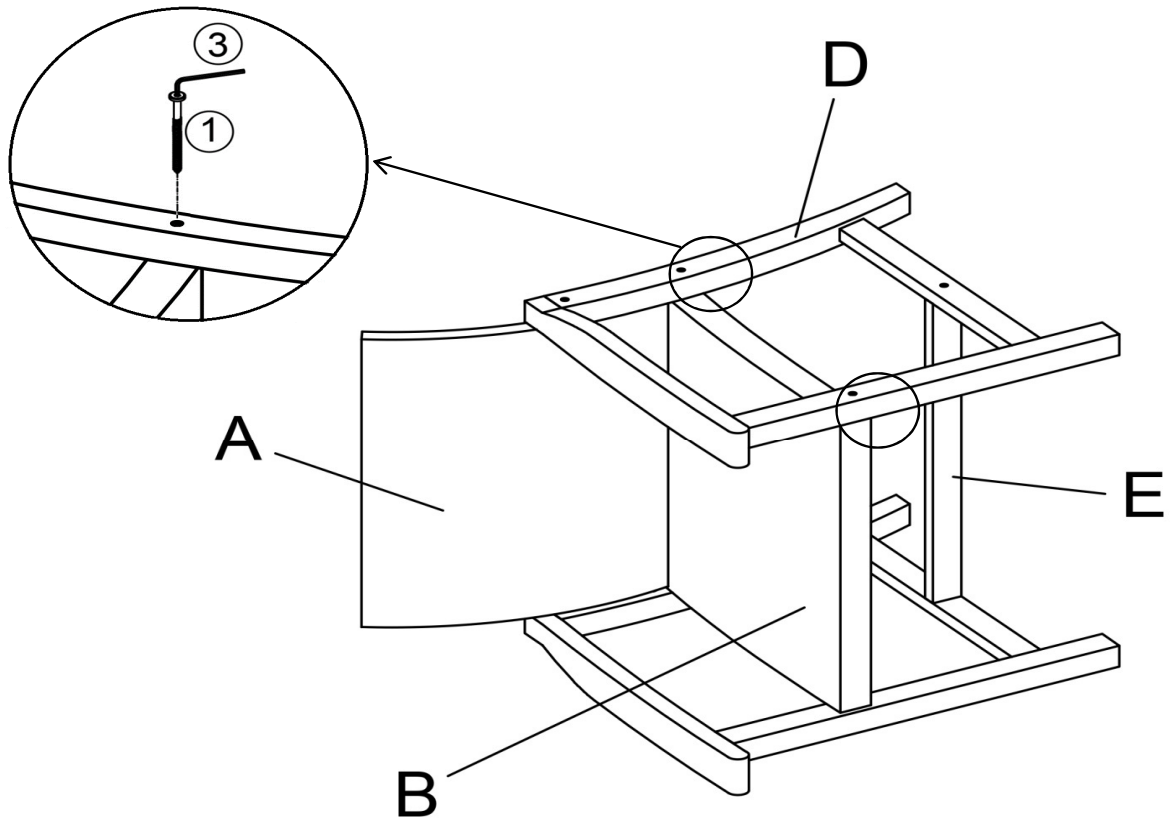

Secure the Right Leg Panel (D) to Seat Panel (B) by using Screw (①) with Allen Key(③).

Do not fully tighten the Screws.

Step 6

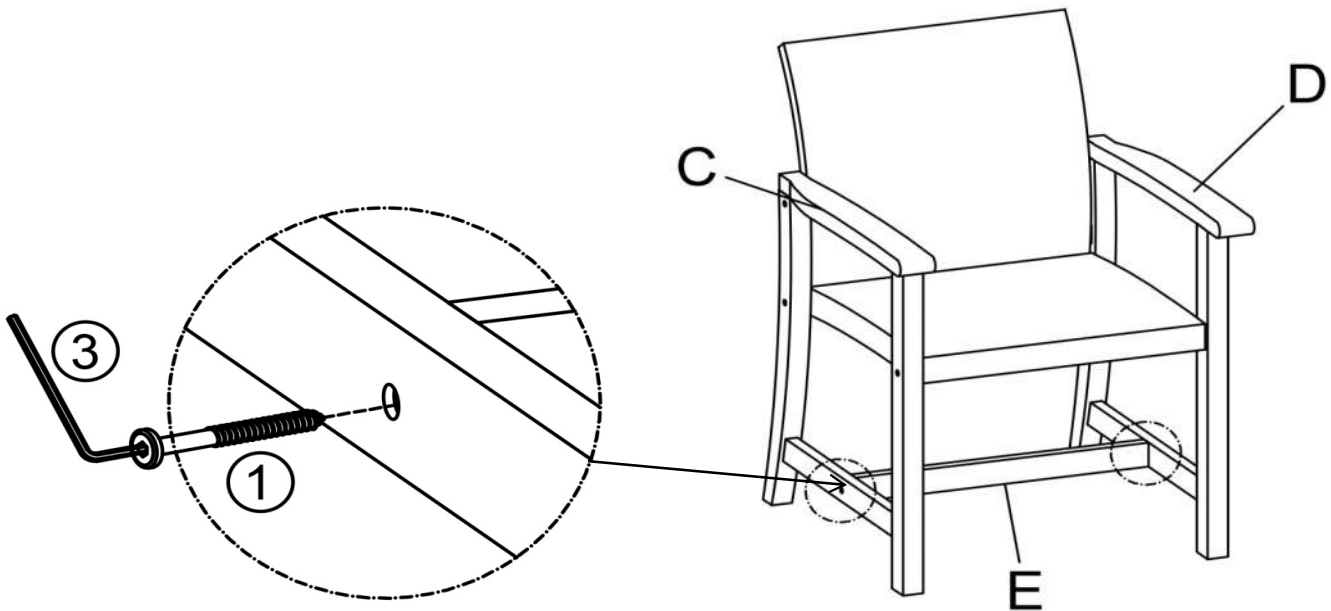

Turn the Chair right side up.

Attach Leg Support Bar (E) to Left Leg Panel (C) and Right Leg Panel (D) by using Screw (①) with Allen Key(③).

Do not fully tighten the Screws.

Step 7

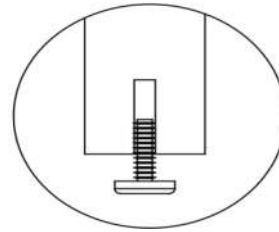
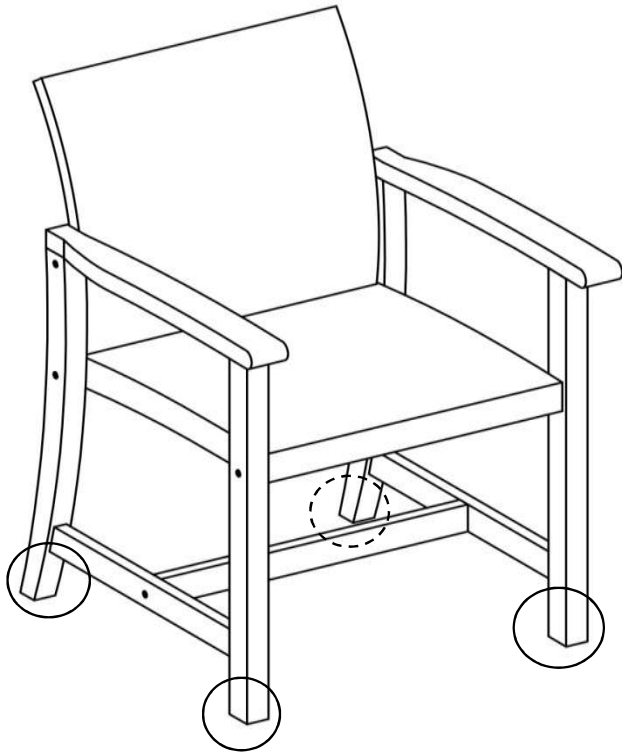

Adjust height for balance

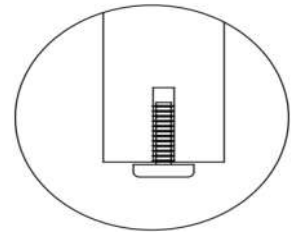

Adjust low for balance

Adjust Pre-installed Levellers
height for balance

Inspect the Chair and make sure all parts are adequately connected.

Carefully sit onto the Chair. This pressure will help align all parts at all joints.

In a sequential manner, tighten all Screws and Bolts at all joints.





















Adjust the Levellers until the Chair is level with the ground.

To adjust the Levellers, get assistance from an adult partner to lift/lean and hold the Chair while you are working.

Your Chair is ready for use.

This Chair can only be used on a flat, level surface.

Care & Maintenance

-   ● Do not put hot items directly on furniture surface
 -   ● Do not clean furniture with harsh cleansers or polish.
 -   ● To obtain the longest lifespan of your outdoor products, minimizing exposure to direct sunlight is recommended.
 -   ● Children should not climb or jump on the furniture.
 -   ● Do not write on furniture without a padded barrier to protect the surface.
 -   ● To obtain the longest lifespan of your outdoor products, avoid extended and lengthy exposure to rain, snow, and direct sunshine. Whenever possible cover the product and /or place under patio or awnings.
 -   ● Not for commercial use. For residential use only .
 -   ● Stains may be removed with mild soap solution and damp cloth.
 -   ● Keep away from sources of ignition.
-
-   ● Dust and pick-up spills using a clean, non-colored, lint-free cloth.