

8' x 5' Metal Grill Gazebo

ASSEMBLY MANUAL

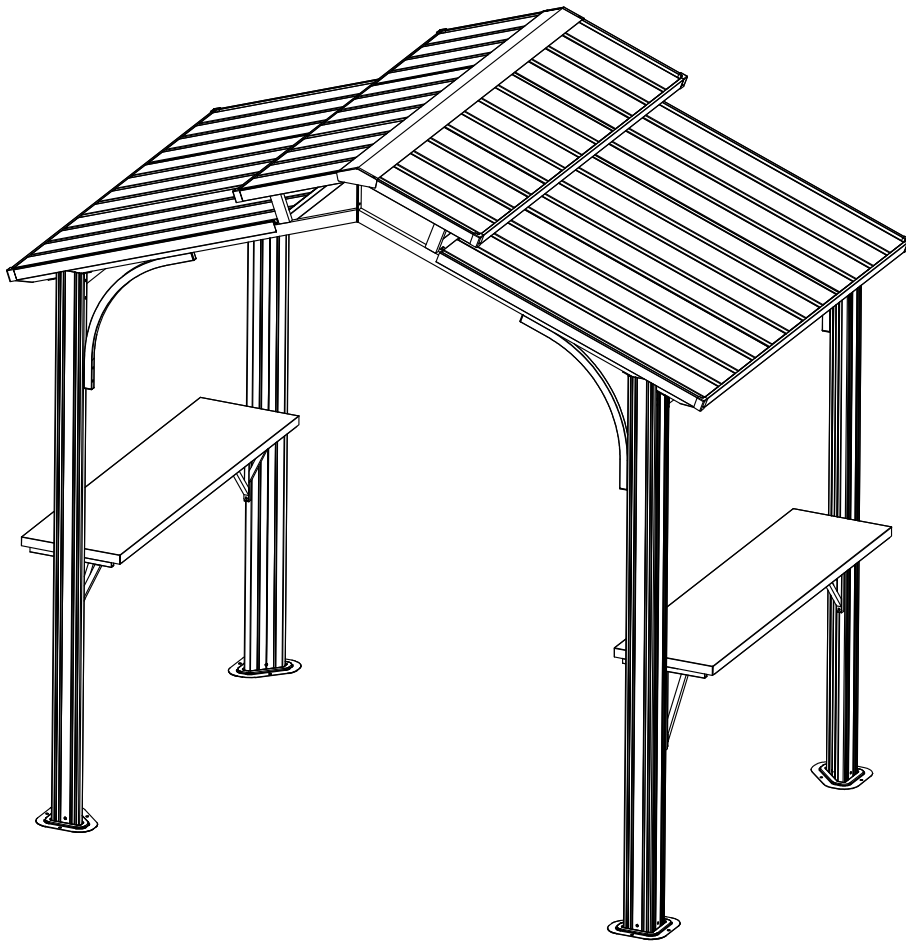

MODEL#:LGMF 1651

Missing part? Damaged? Contact us via email at

service@domioutdoorliving.com

www.domioutdoorliving.com

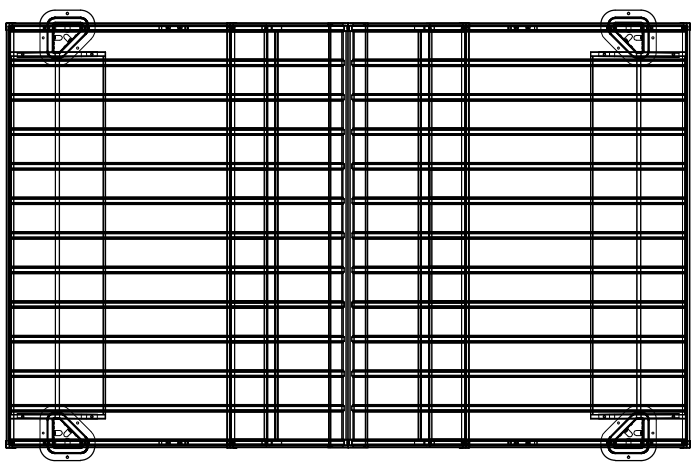
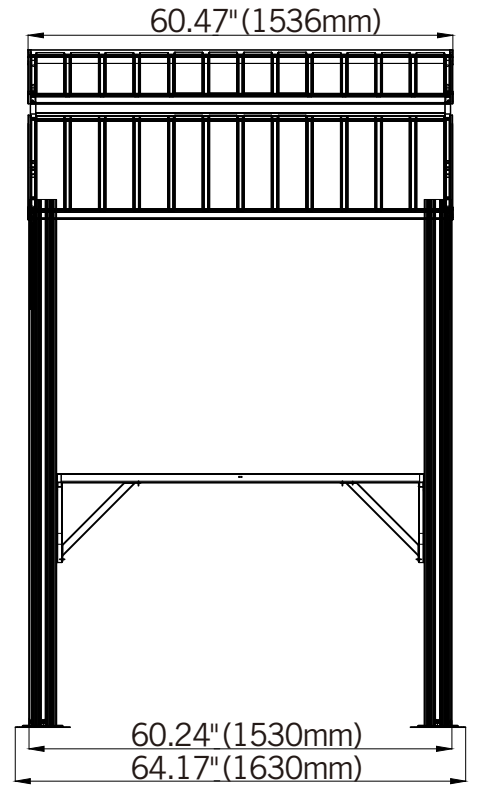
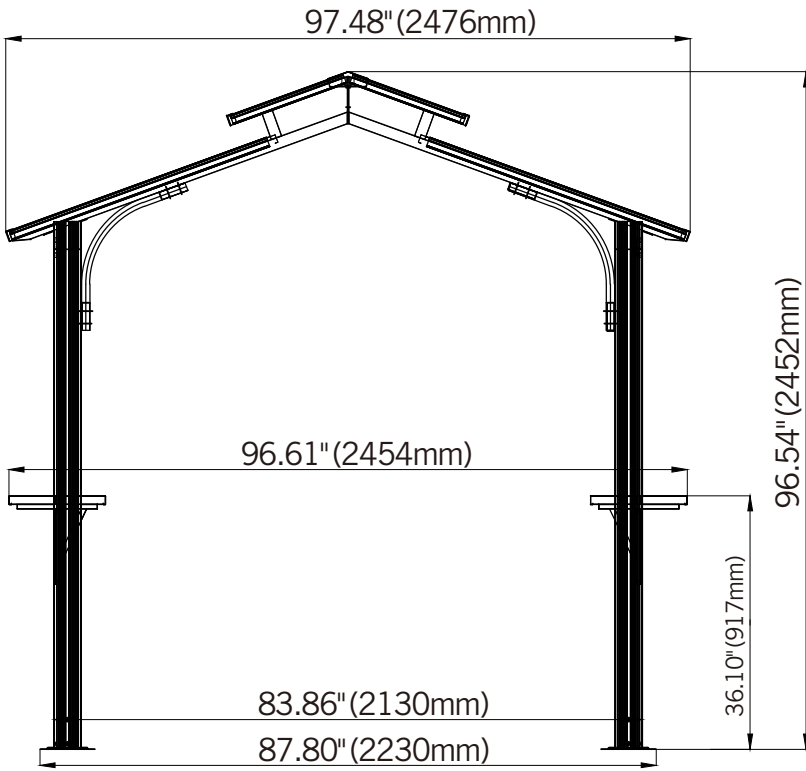

1

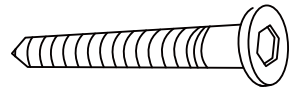
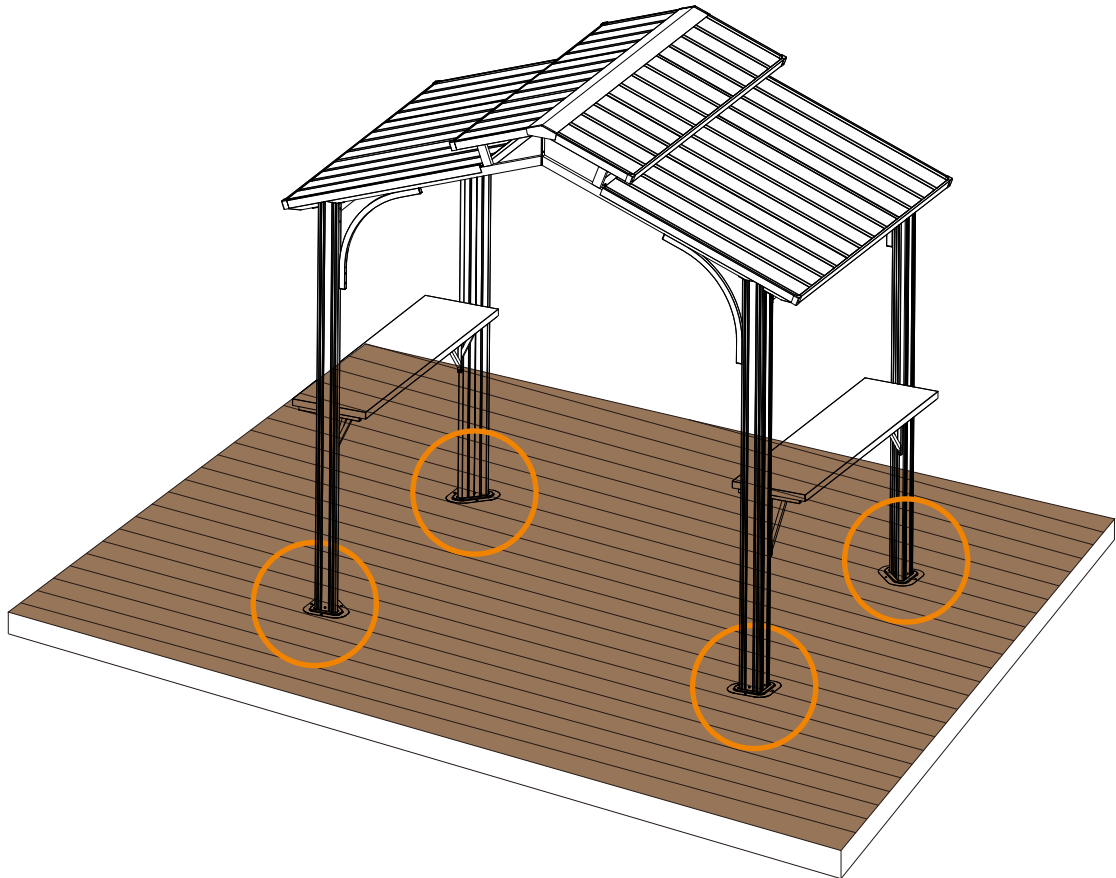

×12

If the deck is hard wood and the depth of it is over 3 inch, you can use **5/16 in. ×4 in. Structural Wood Screw** to mount the gazebo.

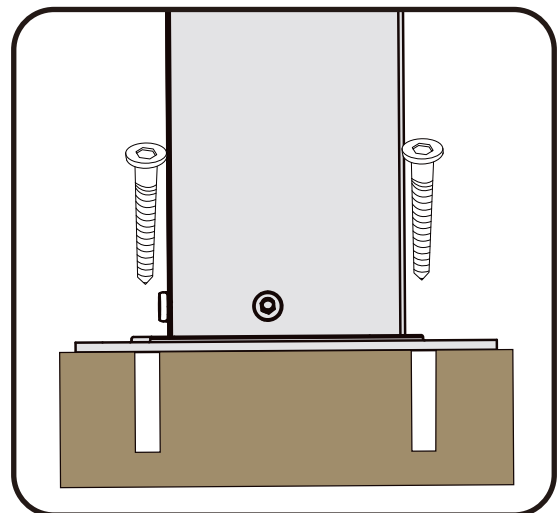
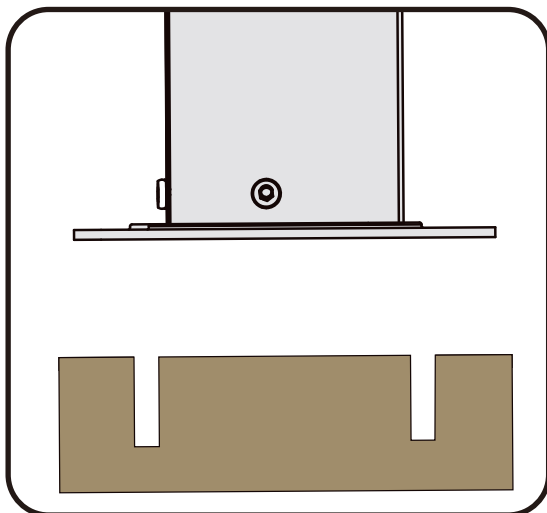

2

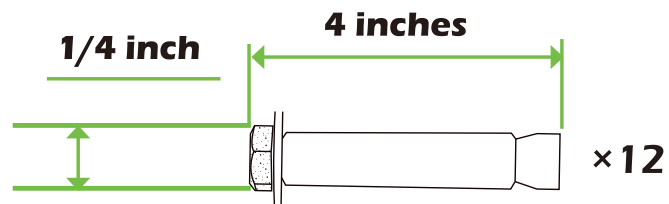
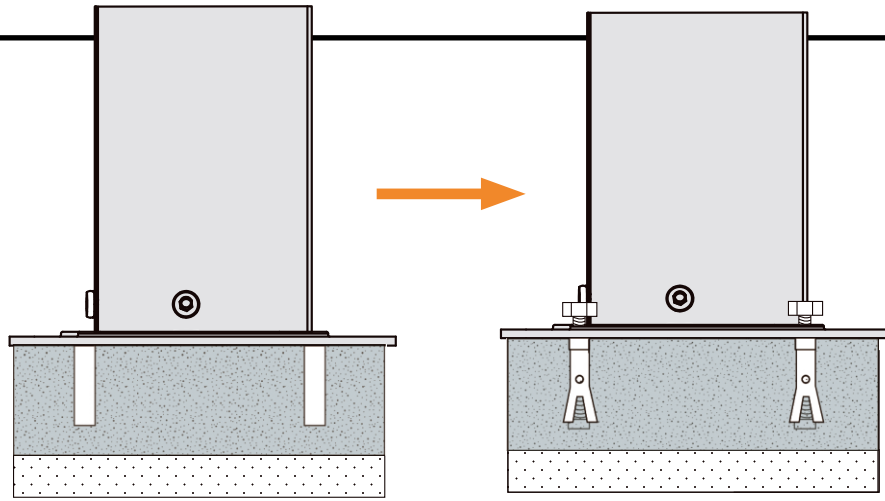

If the ground is concreted and the depth of it is over 3 inch, you can use 1/4 inch expansion bolts to mount the gazebo



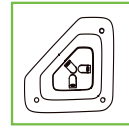
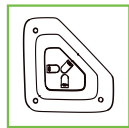
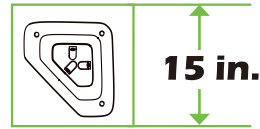
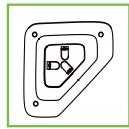





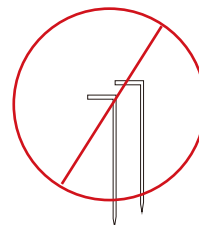



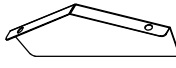
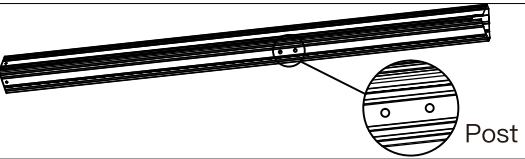
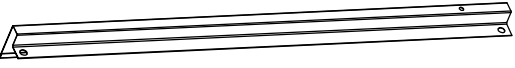
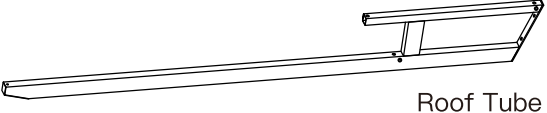

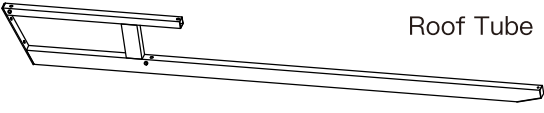
3

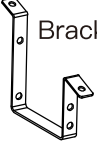

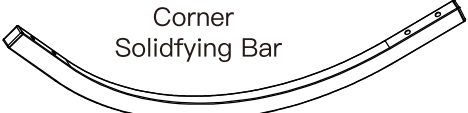
Or you can make a concrete footing for gazebo, **15×15×15 inches** is recommended. use expansion bolts to mount the pergola like (2) shows.

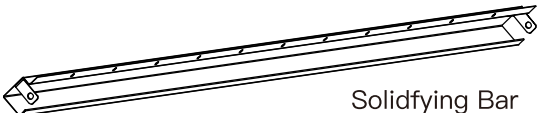
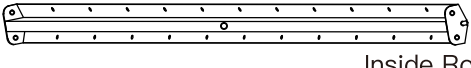
IMPORTANT:
Anchor is not recommended

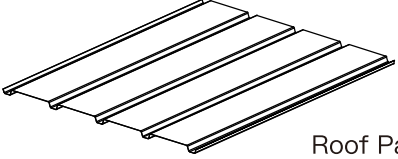
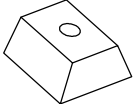

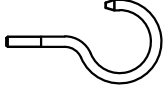
A		2	K		4
A1		1	L		2
A2		1	M		2
B		2	M1		2
B1		2	N		4
C		4	D		4
E		4	E1		4
F		4	Q		2
G		2	R		2
H		1	S		1
I		6	T		26
J		6	U		1
			V		1
2					

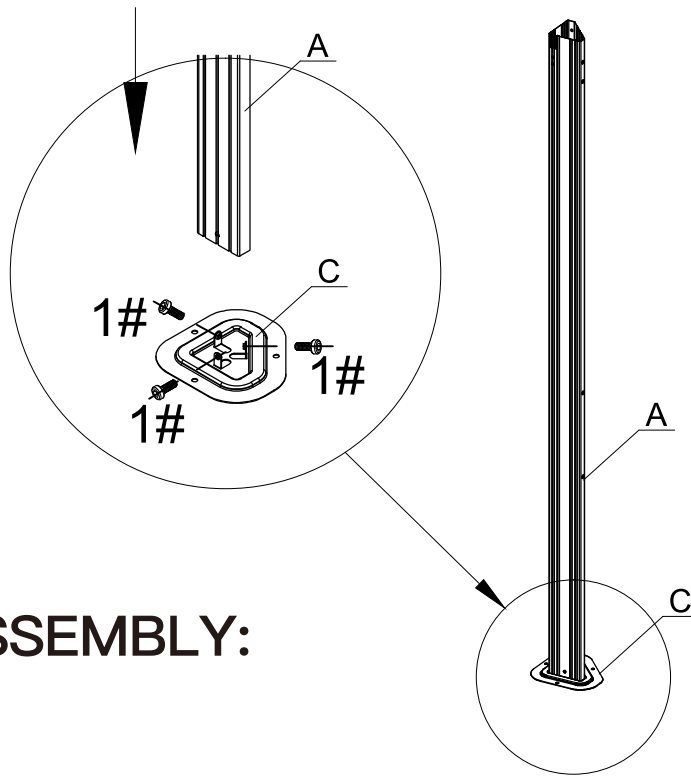
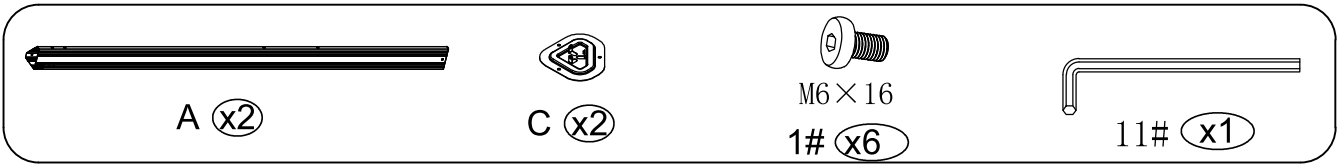

POST ASSEMBLY:

2X

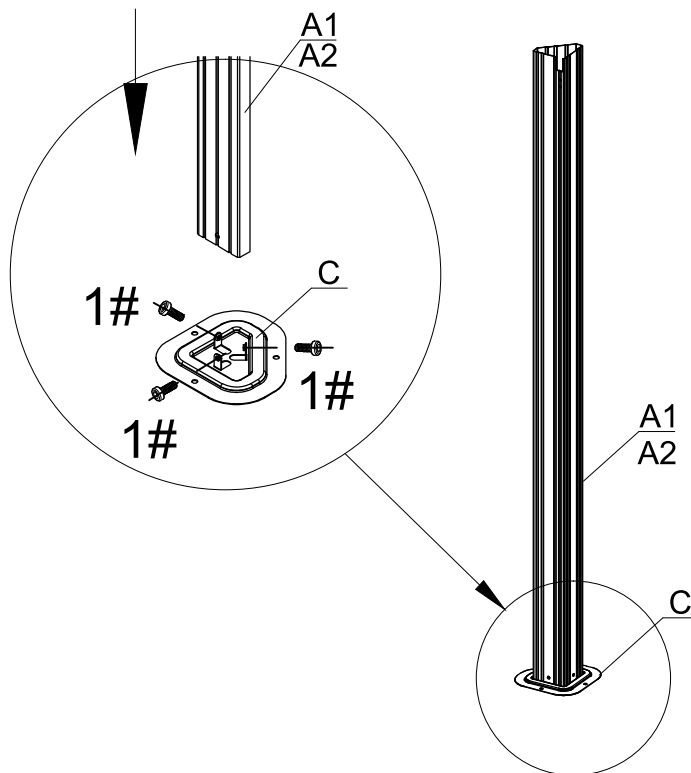
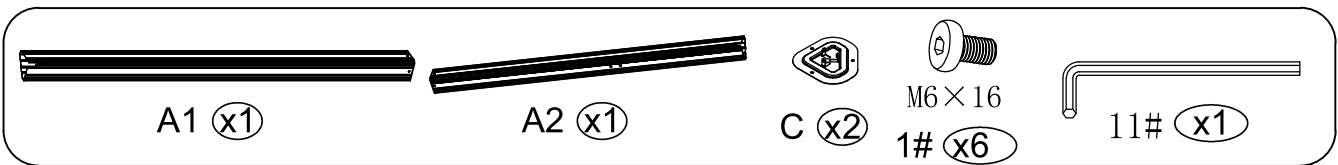

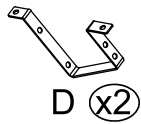

M6 × 16
1# x8

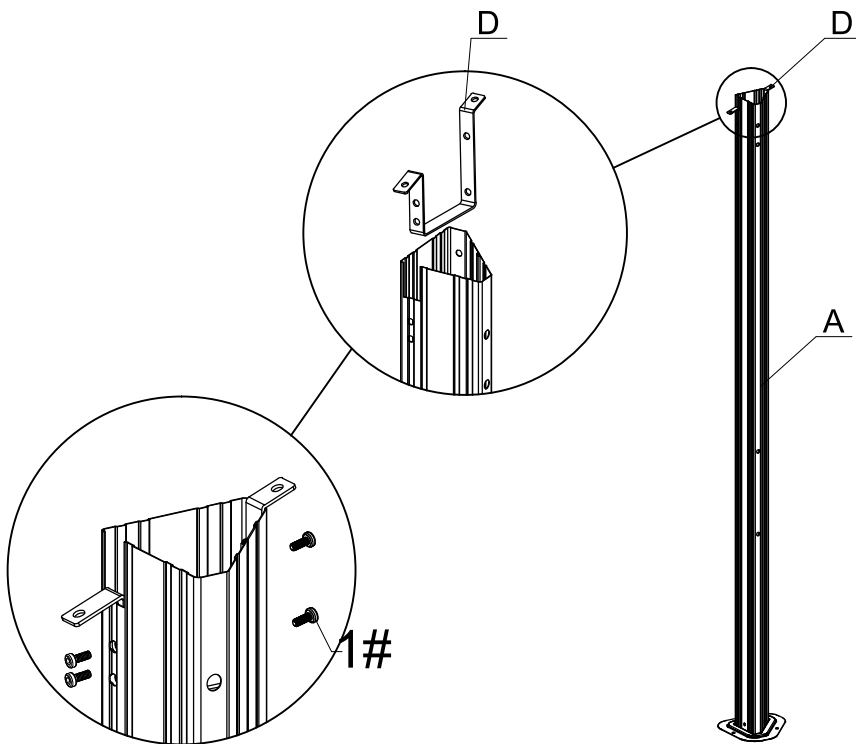
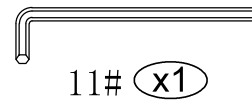

2X

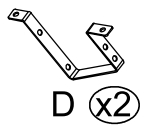

M6 × 16
1# x8

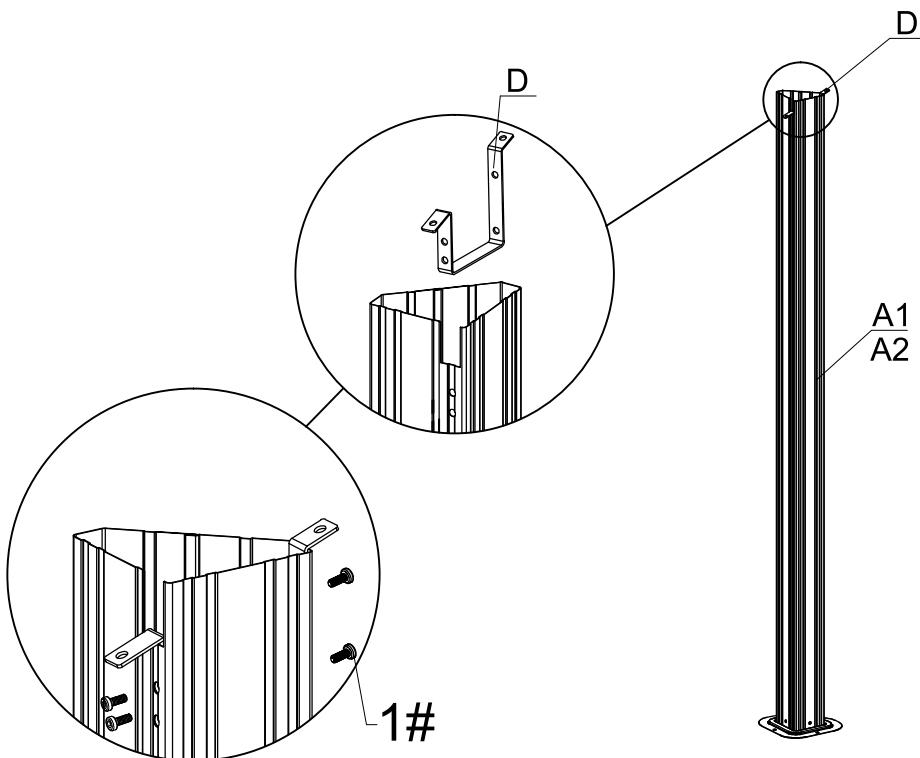
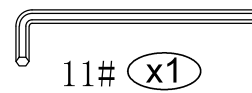

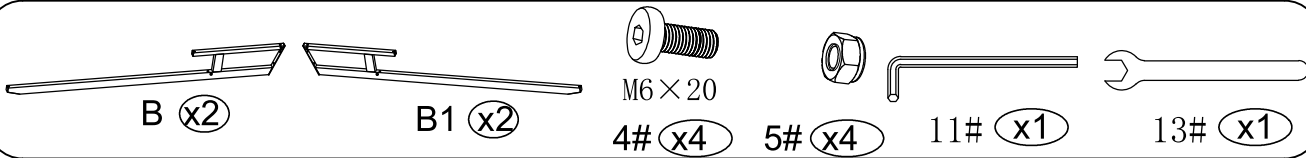

ROOF TUBE ASSEMBLY:

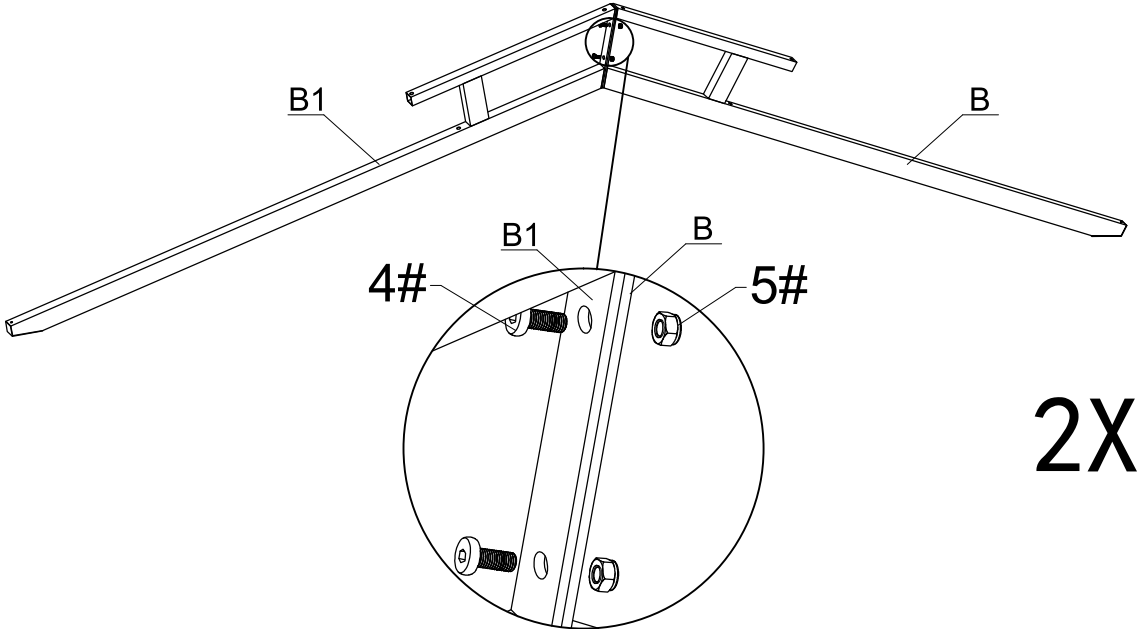

The only difference between A1 & A2 is that there are two holes on A2, which are used to assemble the bottle opener.

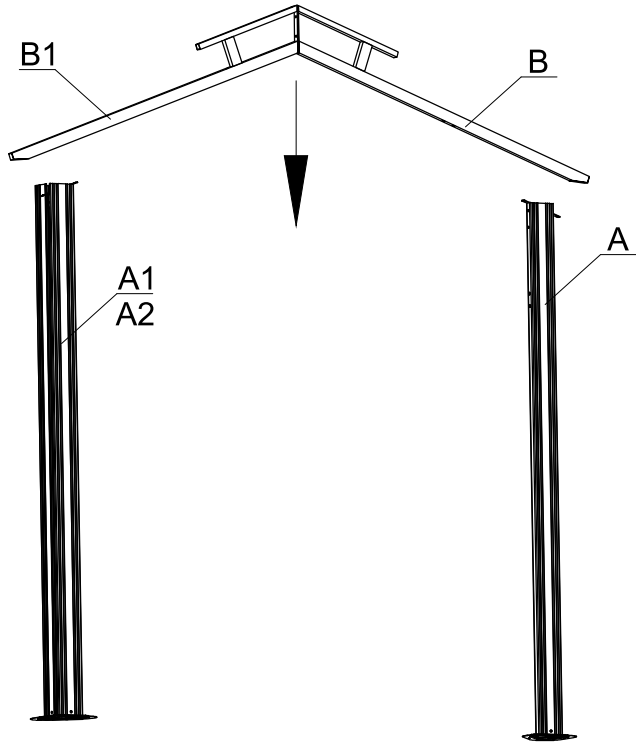



M6 x 16

1# x8



11# x1

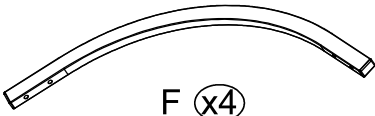
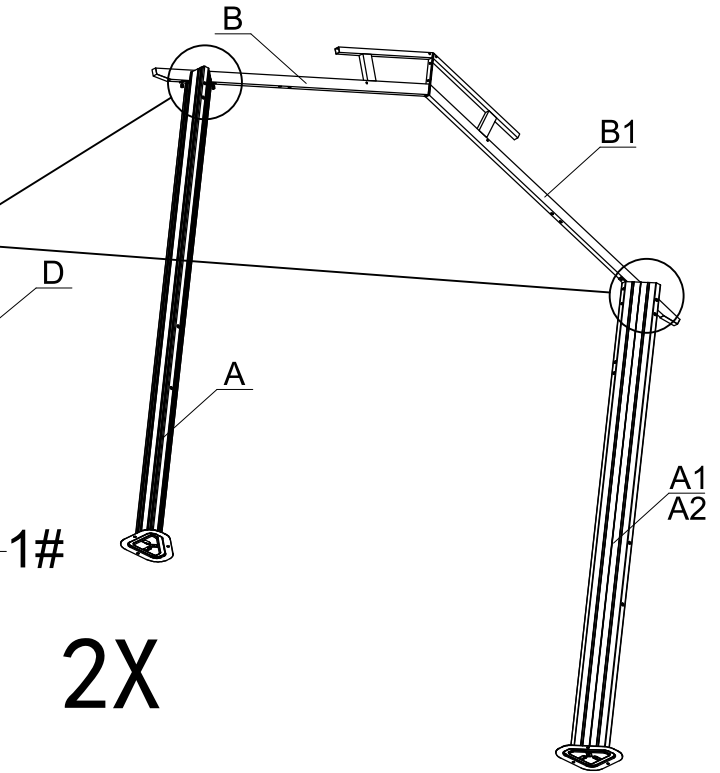
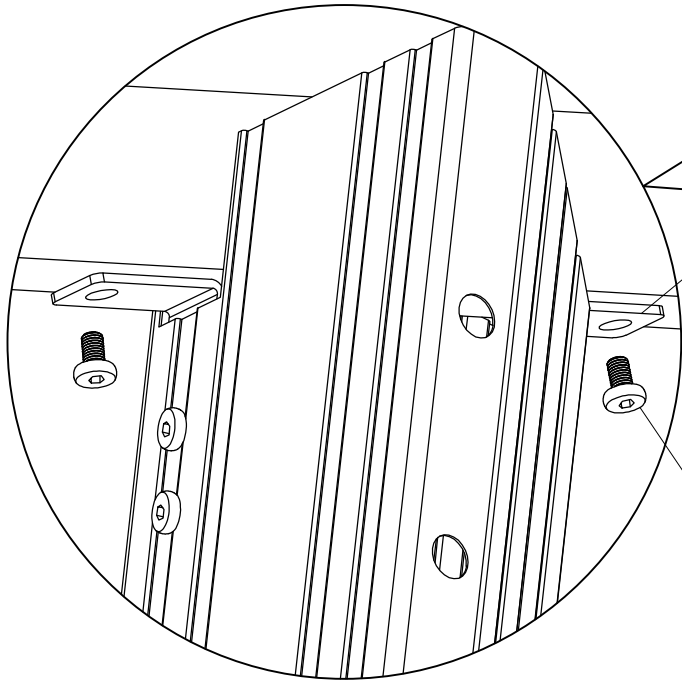

F x4



M6 x 45

2# x16

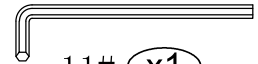

11# x1

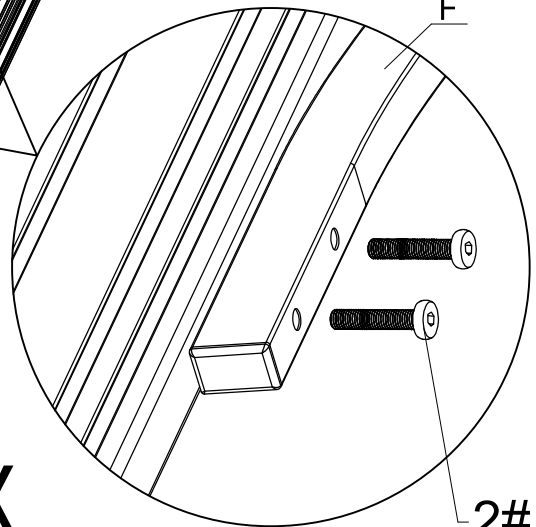
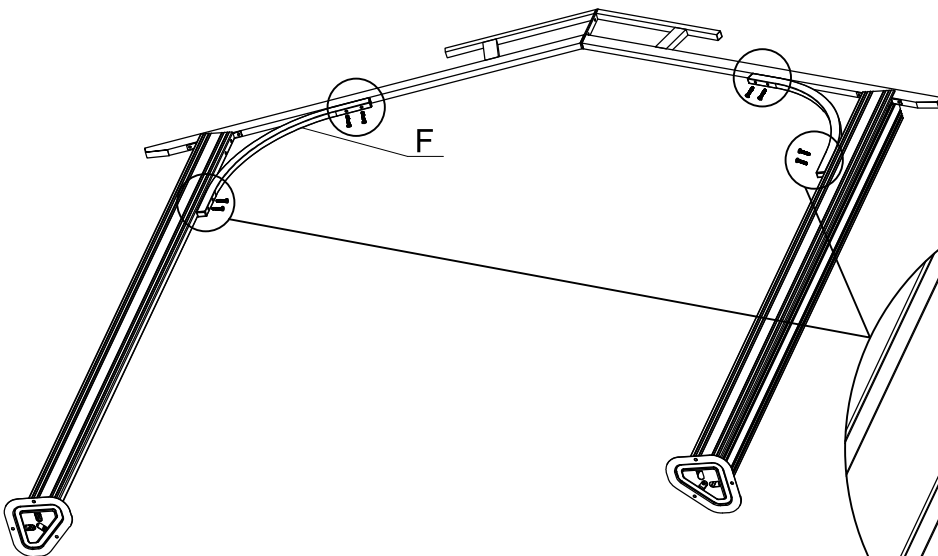

2#

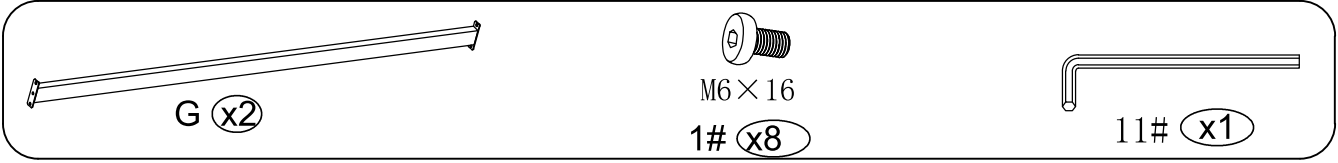

BEAM ASSEMBLY:

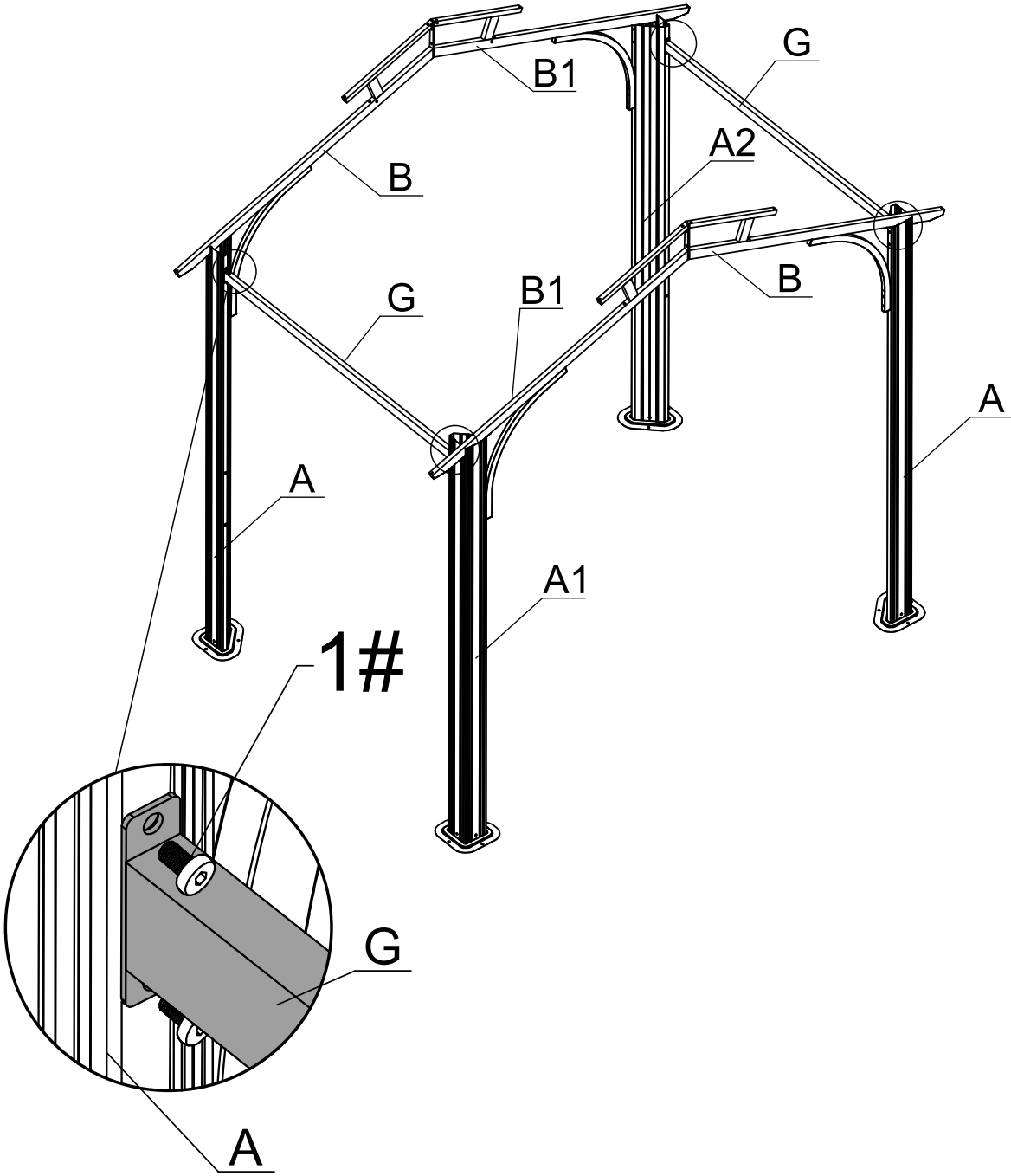

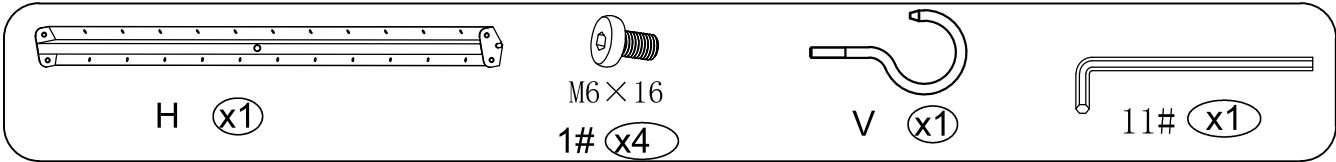

INSIDE ROOF COVER & J-HOOK ASSEMBLY:

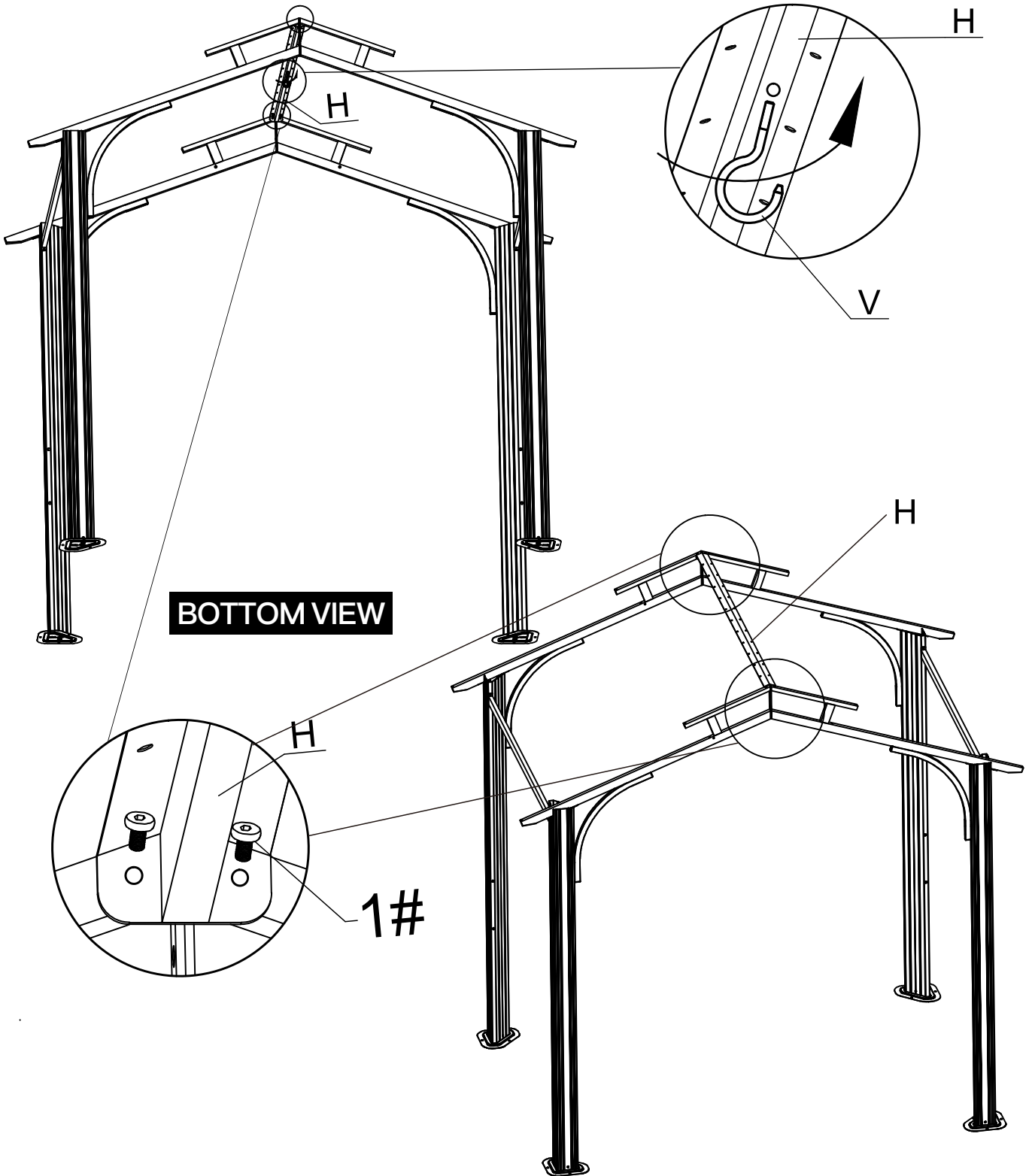

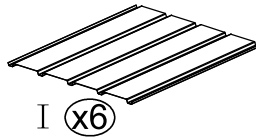
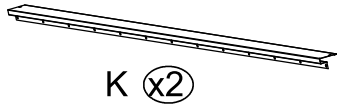

ROOF ASSEMBLY:

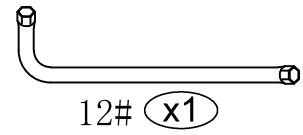
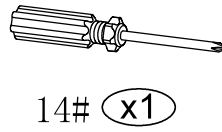
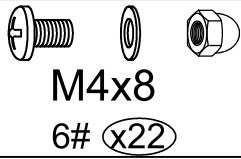
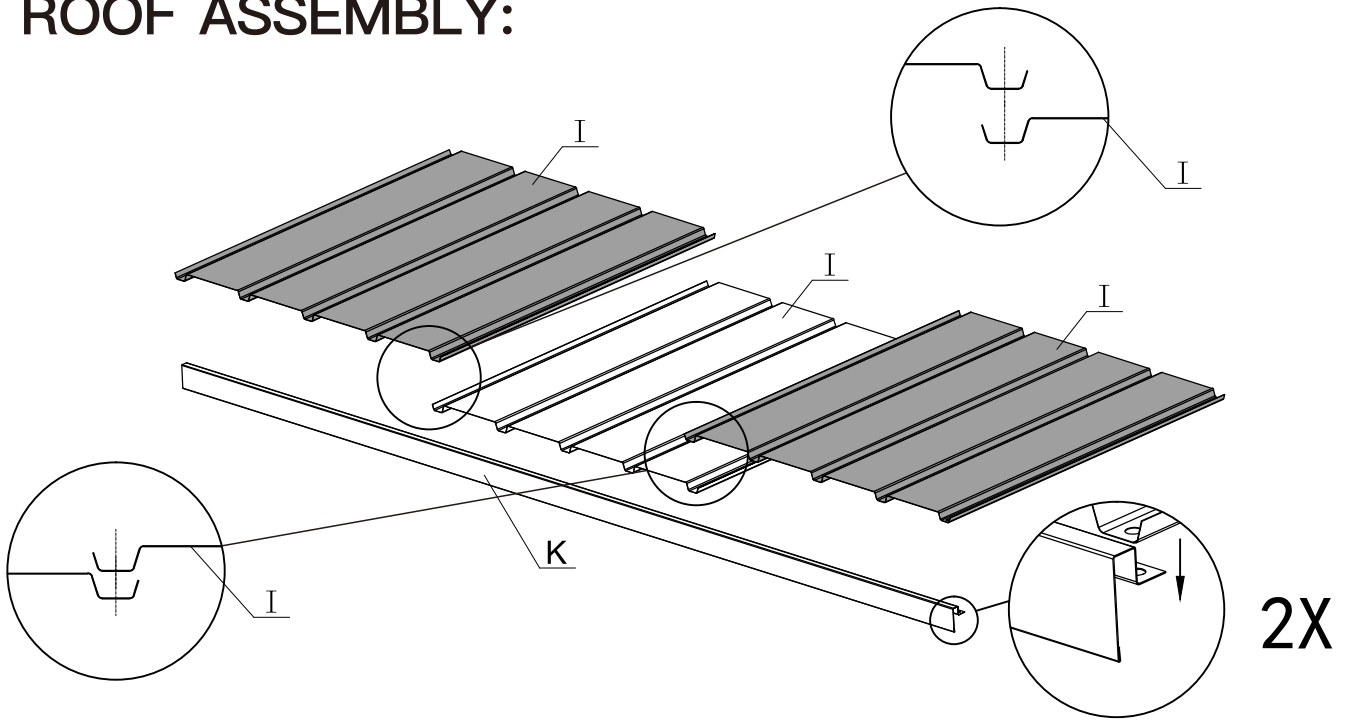

2X

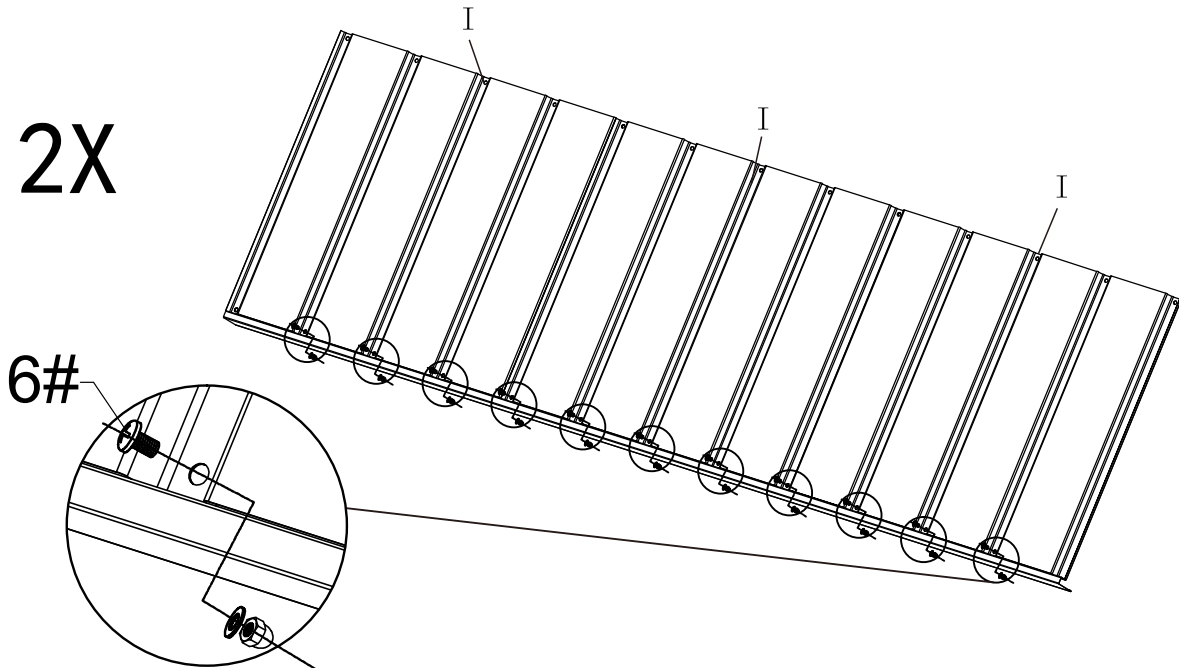

Place 3 roof panel #I ON the finishing bar and secure with 11 bolts #6, gaskets and nuts.
Repeat the above procedures to assemble another side.

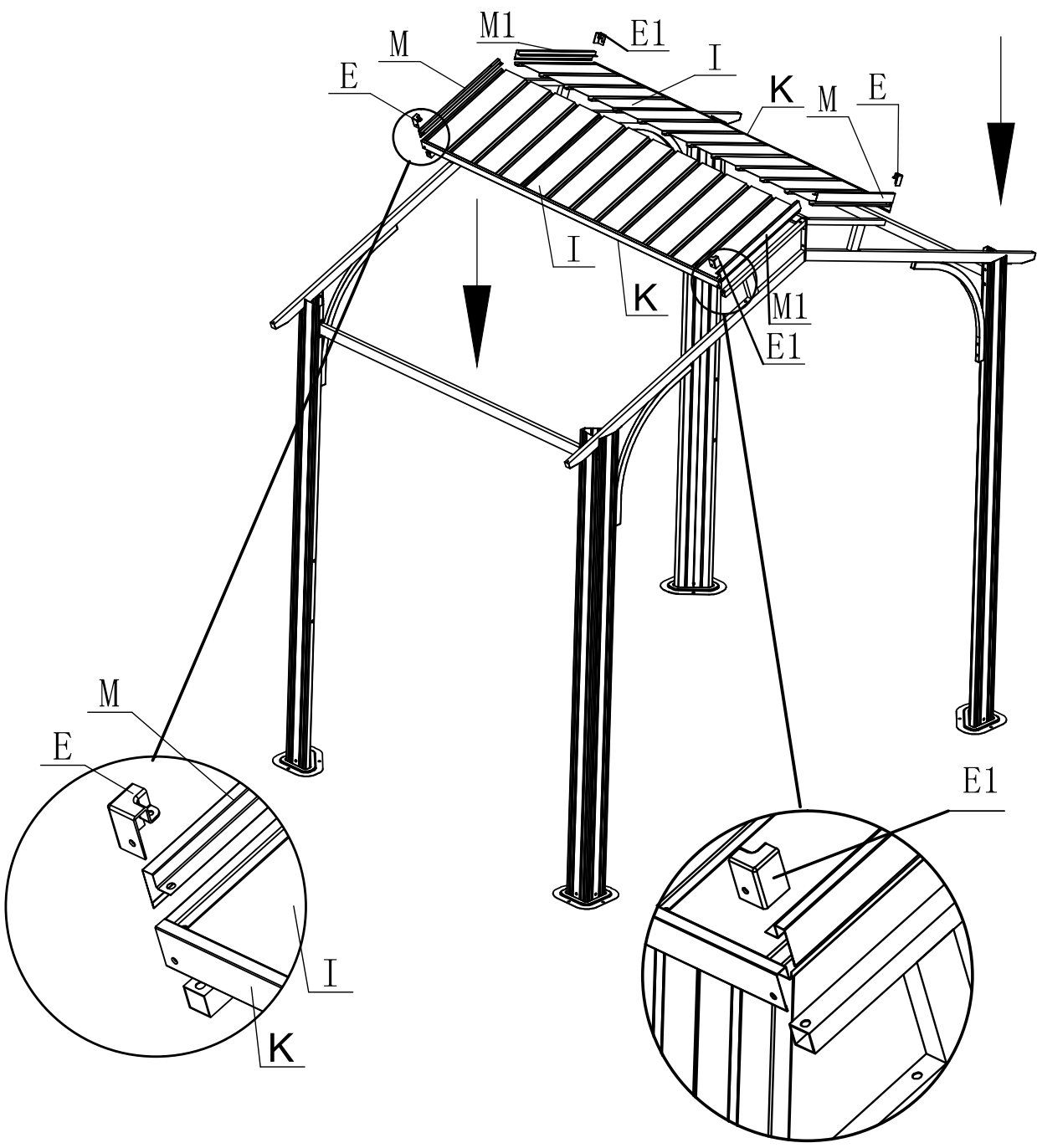
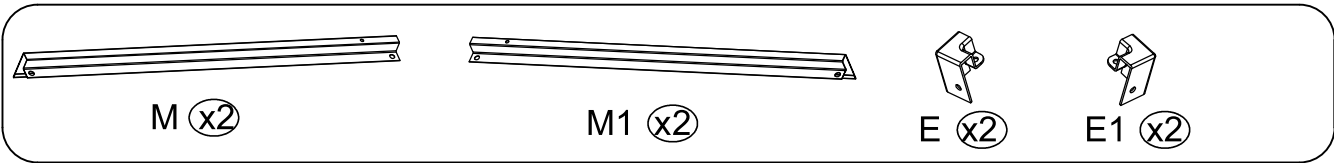

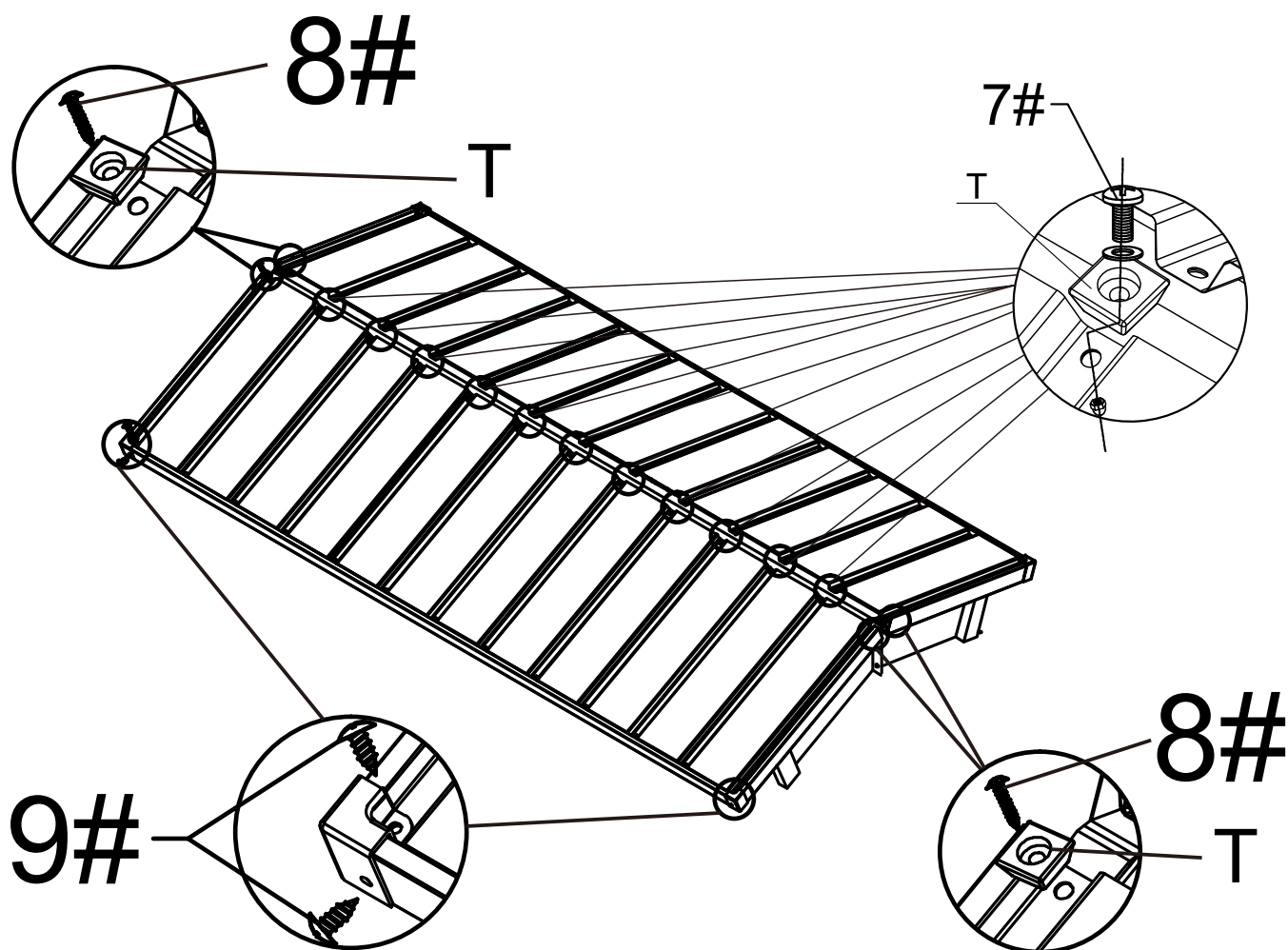
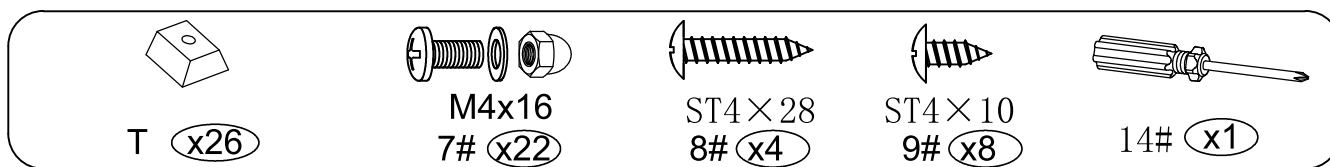

Step1: Insert 11 black rubbers #T to the gap of the roof panel,use 11 bolts #7,gaskets and nuts to fix roof panel to the inside roof cover #H. Repeat the above procedures to assemble the opposite side.

Step2: Use 2 bolt #8 and black rubbers #T to fix part #M and #M1 to the inside roof cover #H.

Repeat the above procedures to assemble the opposite side.

Step3: Use 2 self-tapping bolts #9 and fixing end #E to fix part #K and #M, Use 2 bolt #9 and fixing bracket #E1 to fix part #K and #M1 .

Repeat the above procedures to assemble the opposite side.

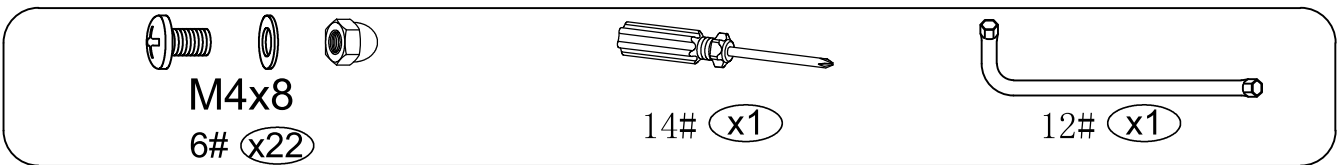
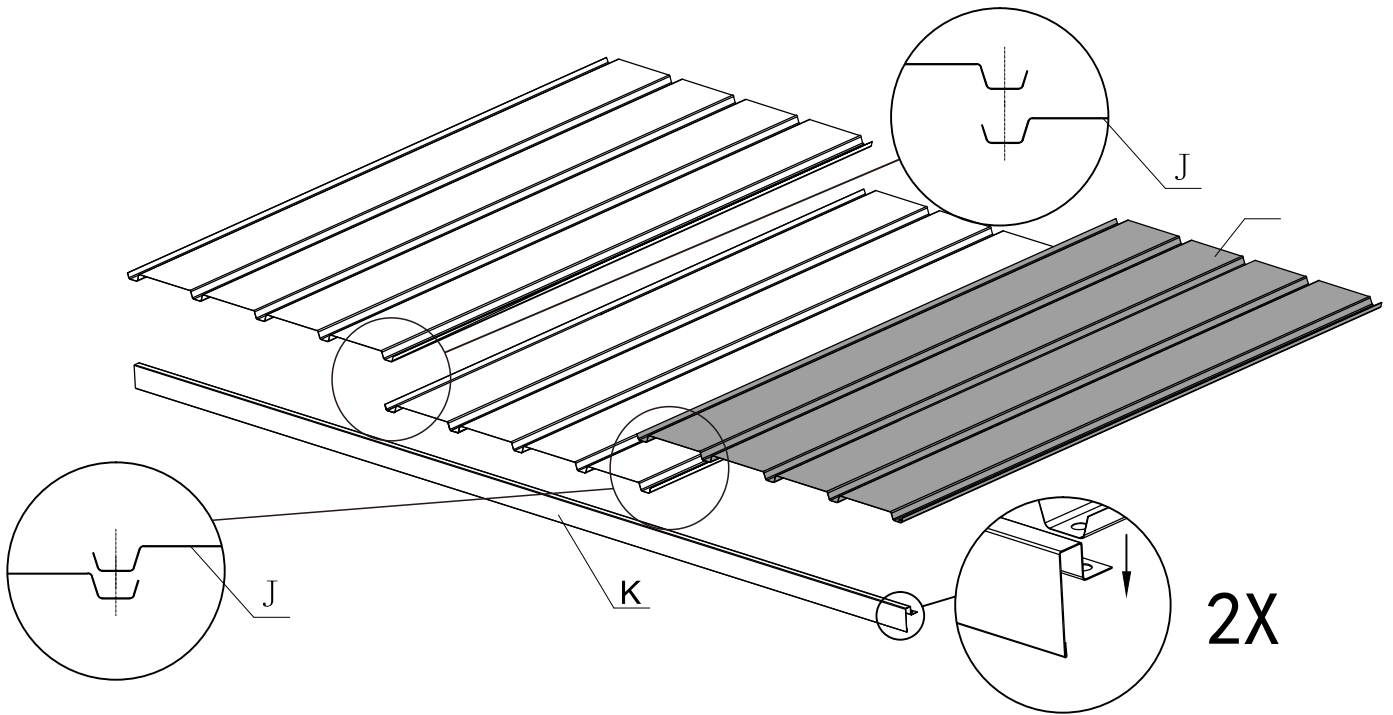
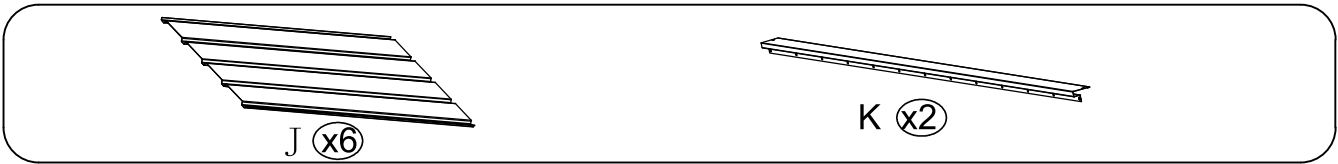

2X

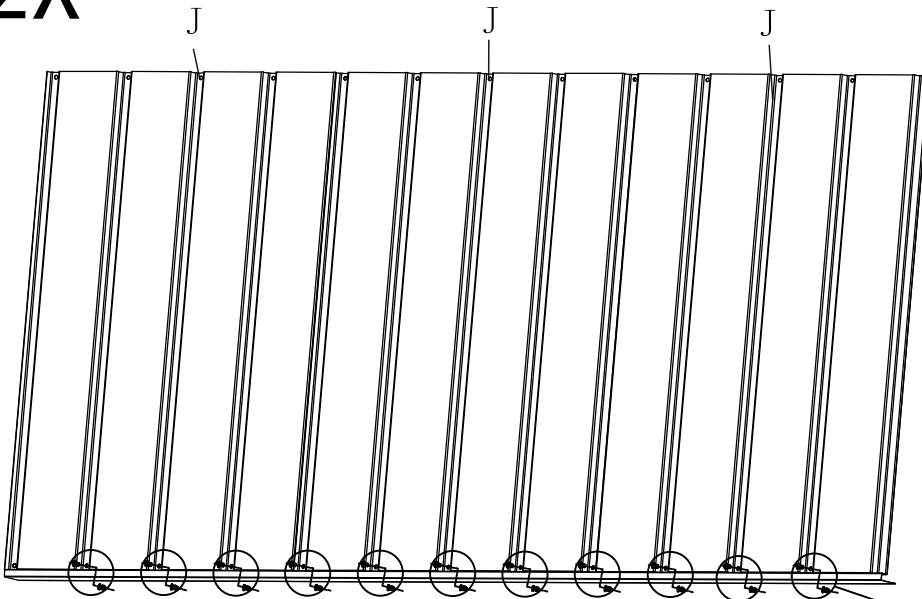

Place 3 roof panel #J
ON the finishing bar and
secure with 11 bolts #6,
gaskets and nuts.

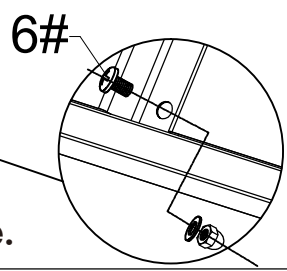

Repeat the above procedures to assemble another side.

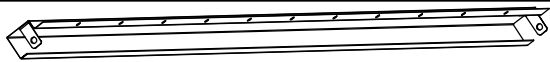

R (x2)

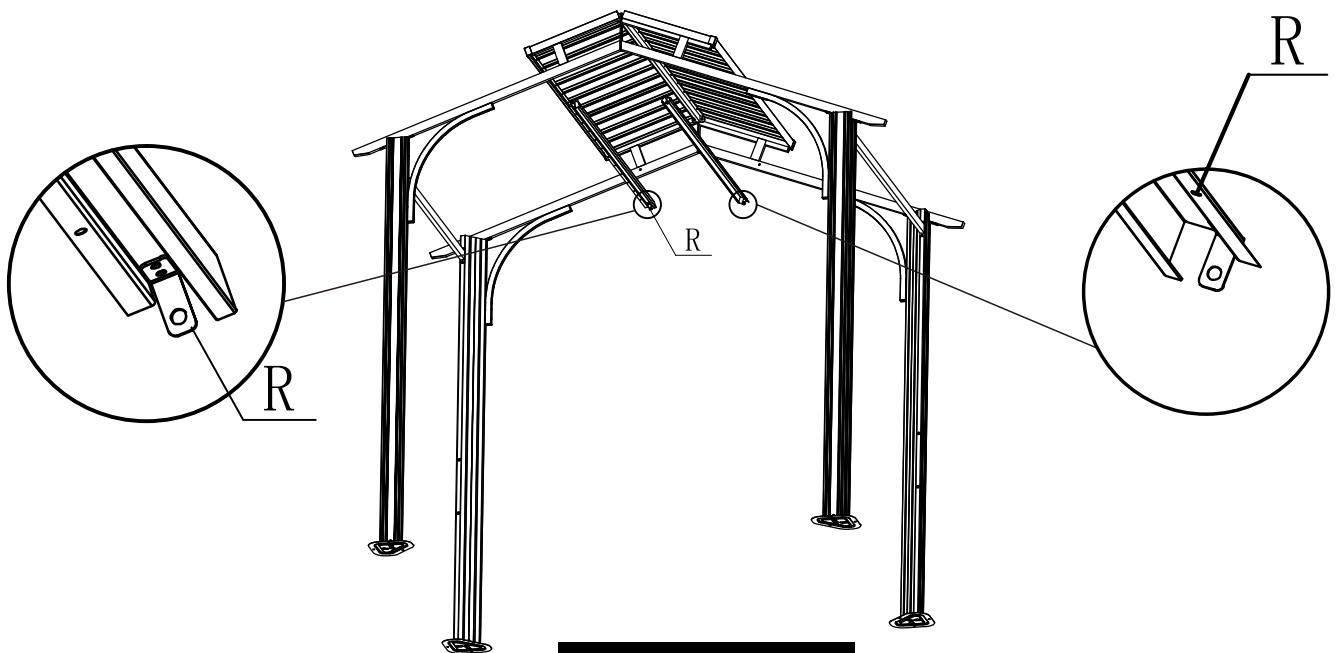

BOTTOM VIEW



M6 × 16

1# (x4)

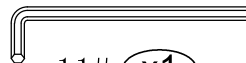

11# (x1)

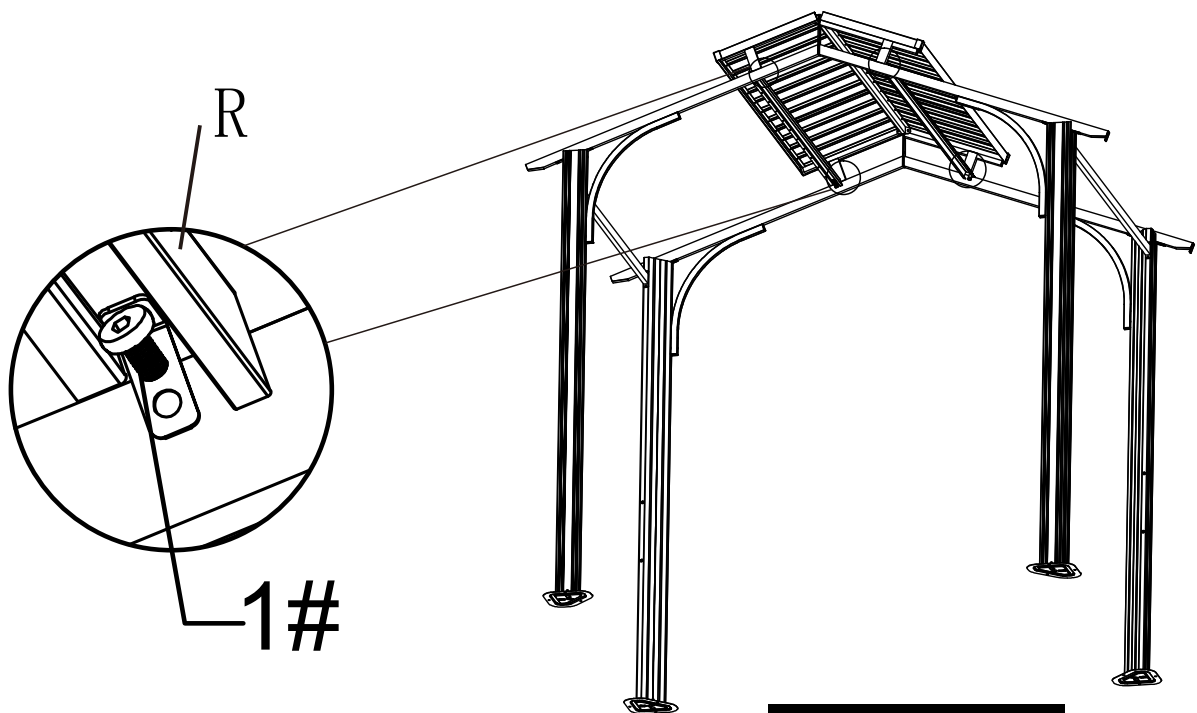

BOTTOM VIEW

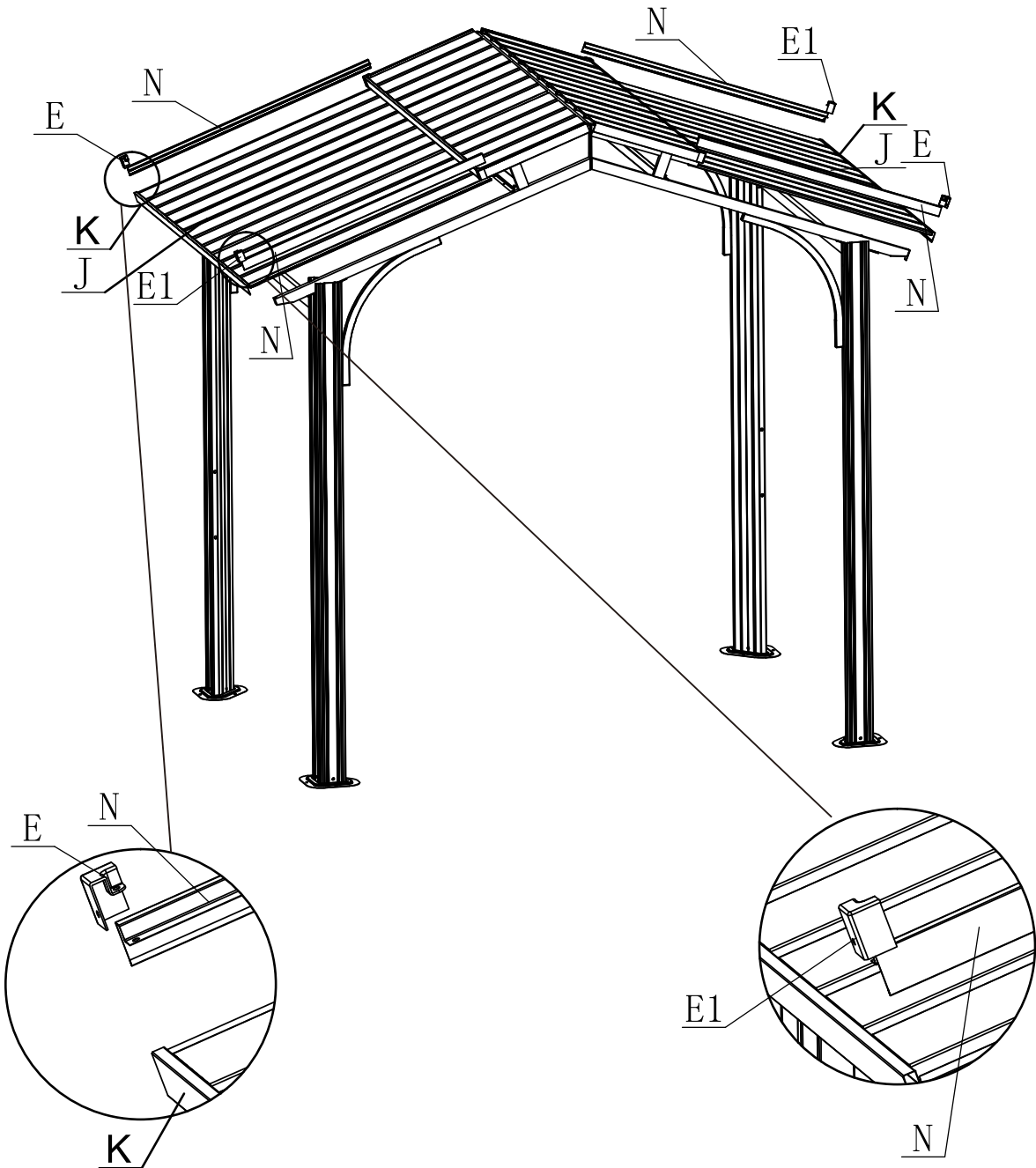
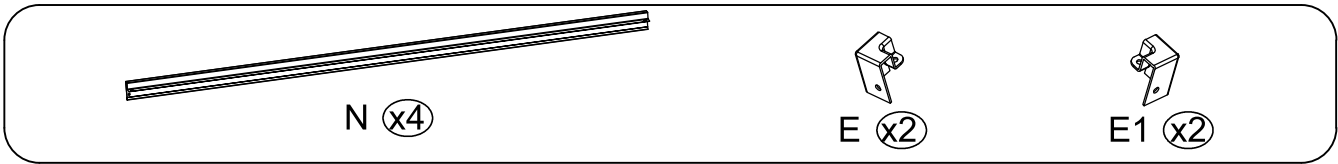

EXPLODED VIEW



M4x8
6# (x22)



ST4x10
9# (x12)

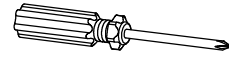

14# (x1)

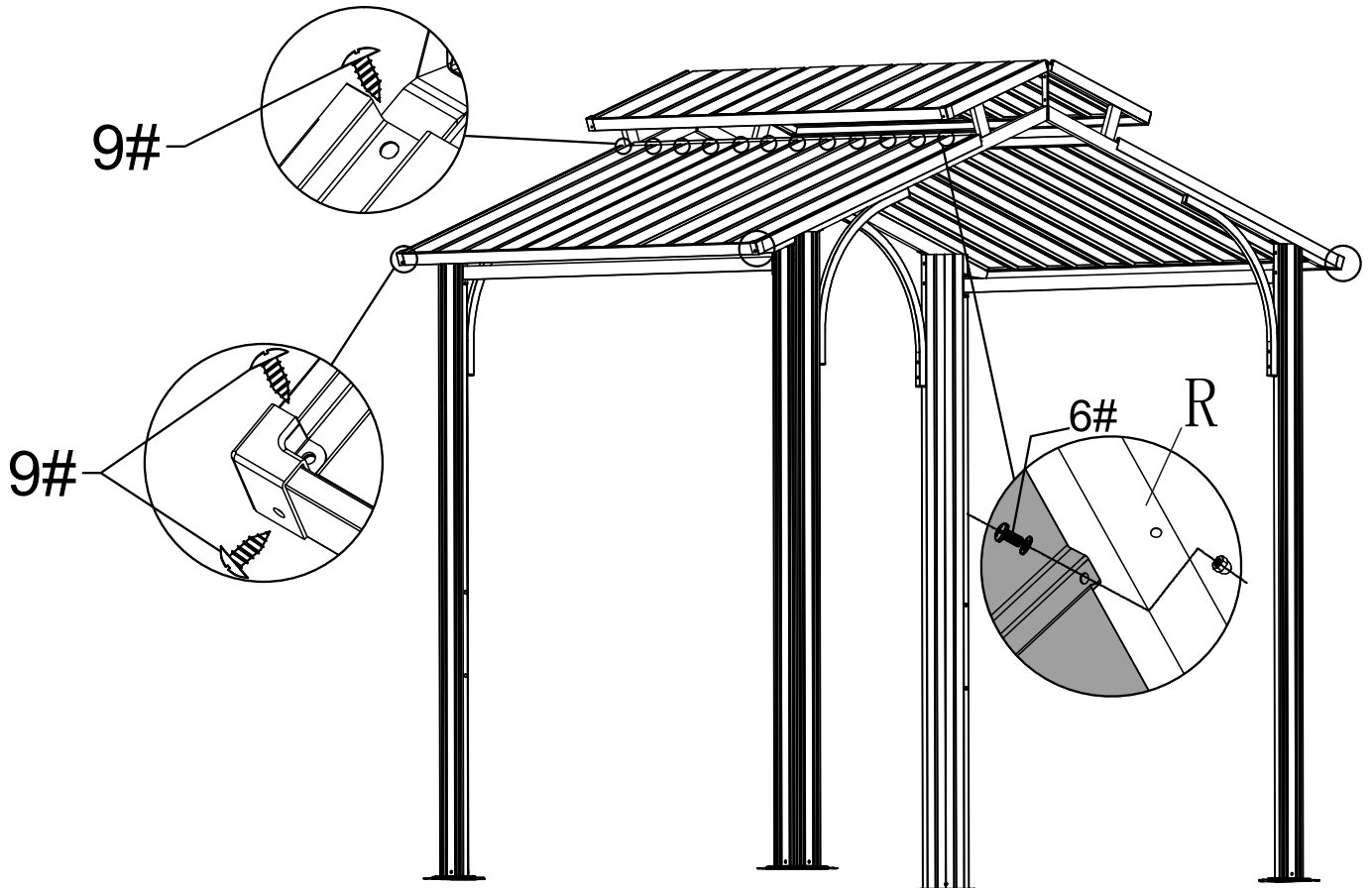

Step1: Use 11 bolts #6,gaskets and nuts to fix roof panel to the solidifying bar #R.

Step2: Use 1 self-tapping bolt #9 to fix part #N to the roof tube.
Repeat the above procedure to the other 3 sides.

Step3: Use 2 self-tapping bolts #9 and fixing end #E to fix part #K and #N , Use 2 bolt #9 and fixing bracket #E1 to fix part #K and #N .
Repeat the above procedures to assemble the opposite side.

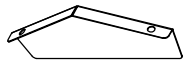

L (x2)

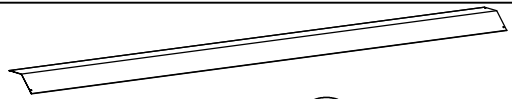

S (x1)

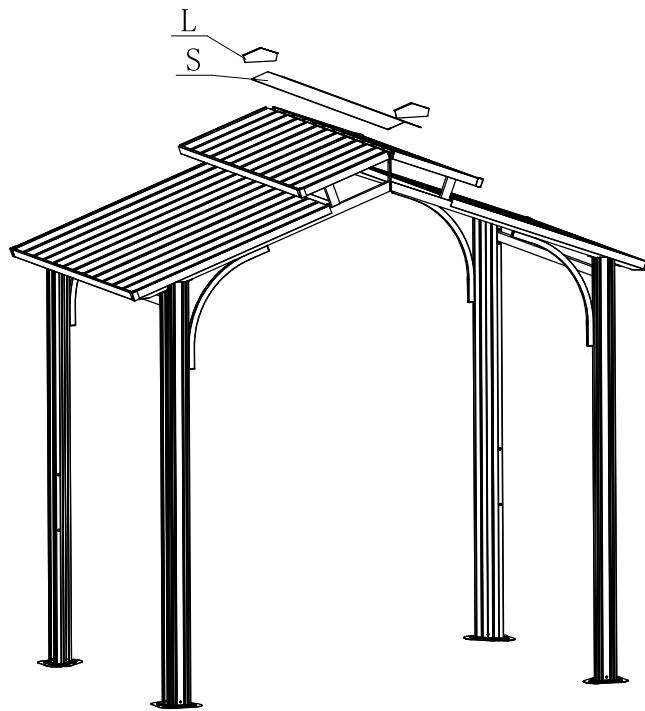

ST4 x 10
9# (x4)



D4 H2
10# (x4)

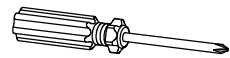

14# (x1)

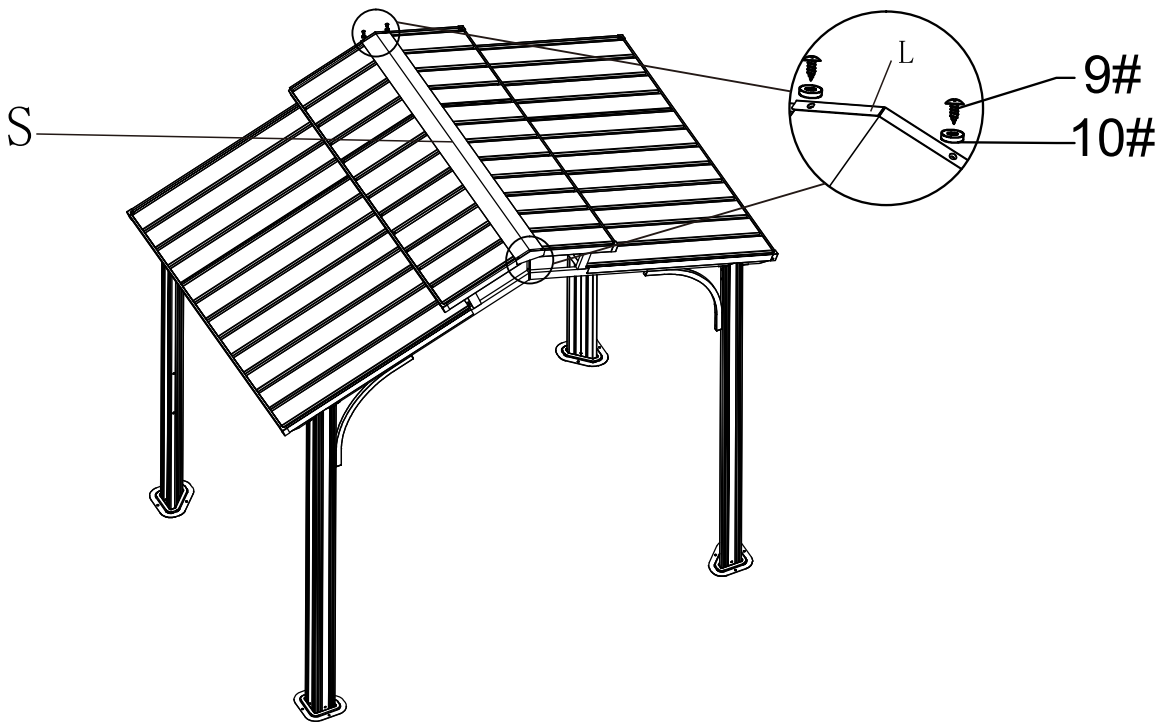



○ x4

TABLE ASSEMBLY:

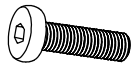
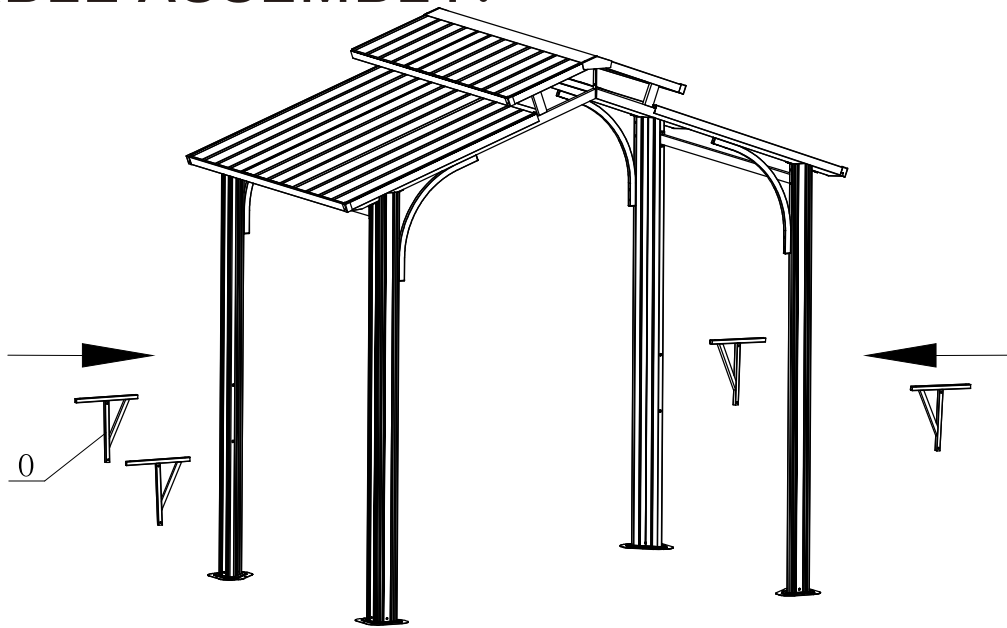

M6 × 32

3# x4

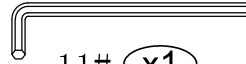

11# x1

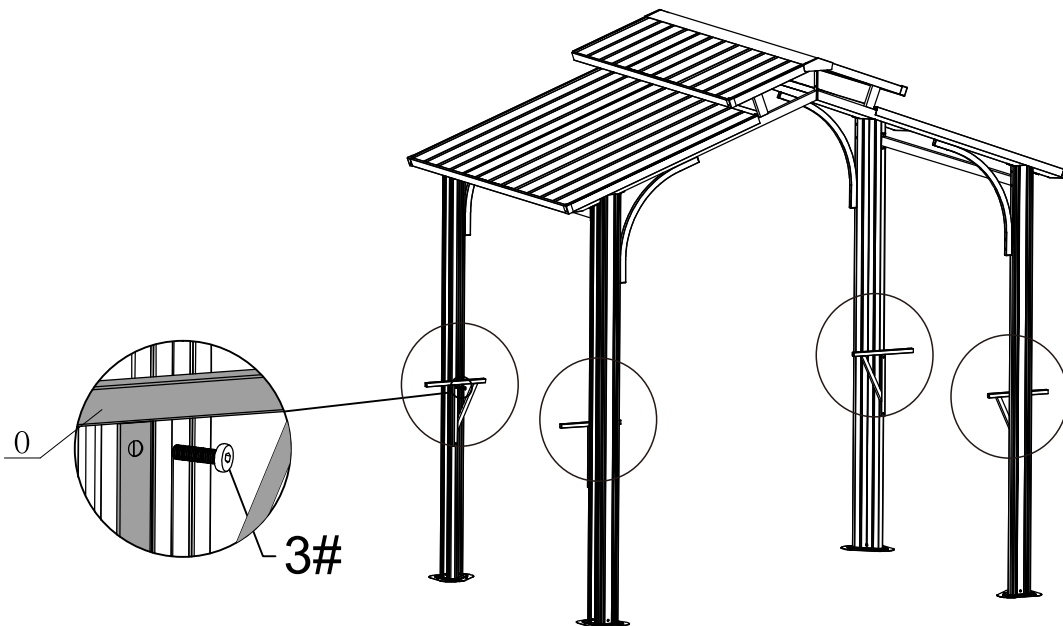

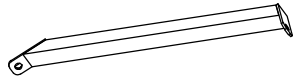

P (x4)



M6 x 32

3# (x4)



11# (x1)

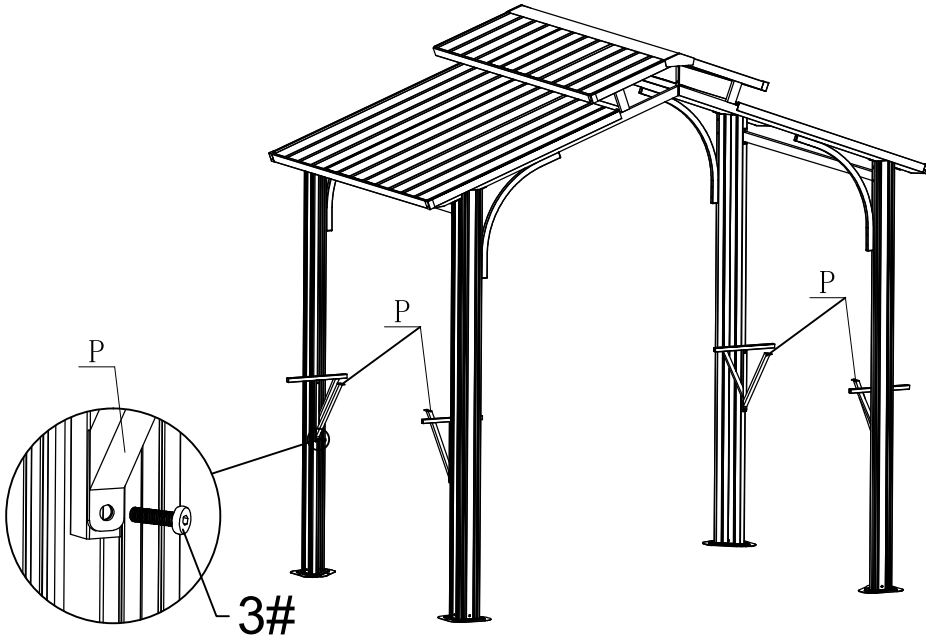

Q (x2)

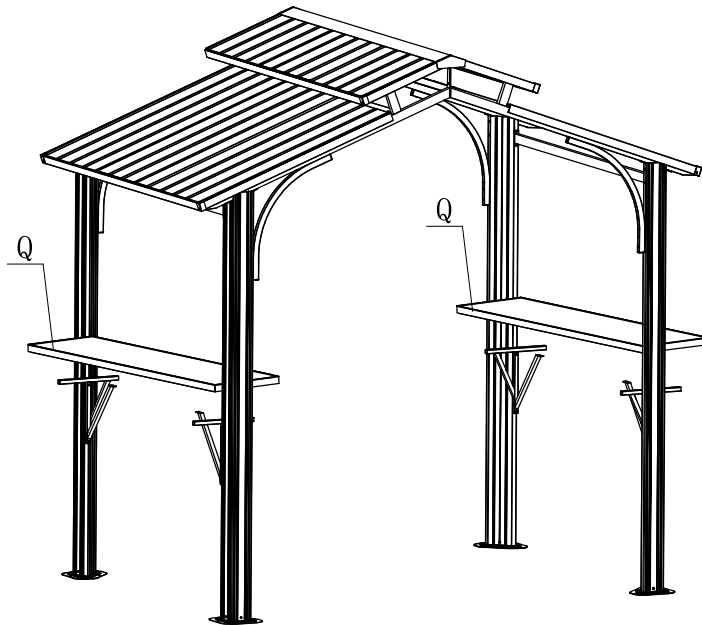

M6 × 16
1# (x4)

M6 × 32
3# (x8)

11# (x1)

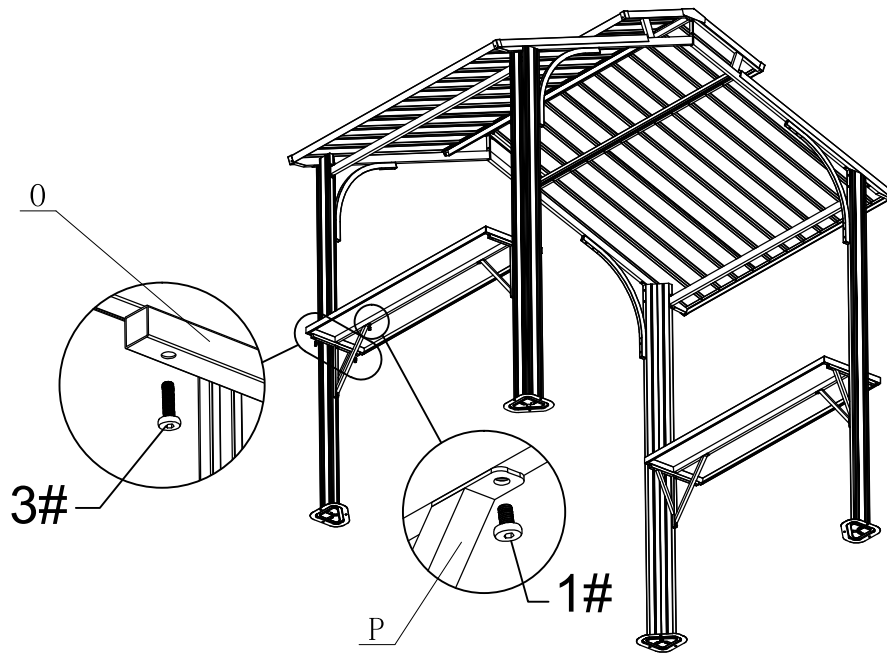

Use 2 bolts #3 to fix part #Q with #O;
Use 1 bolt #1 to fix part #Q with #P.

Repeat the above procedures to assemble the other 3 sides.

BOTTOM VIEW

M6 × 16
1# (x2)

U (x1)

11# (x1)

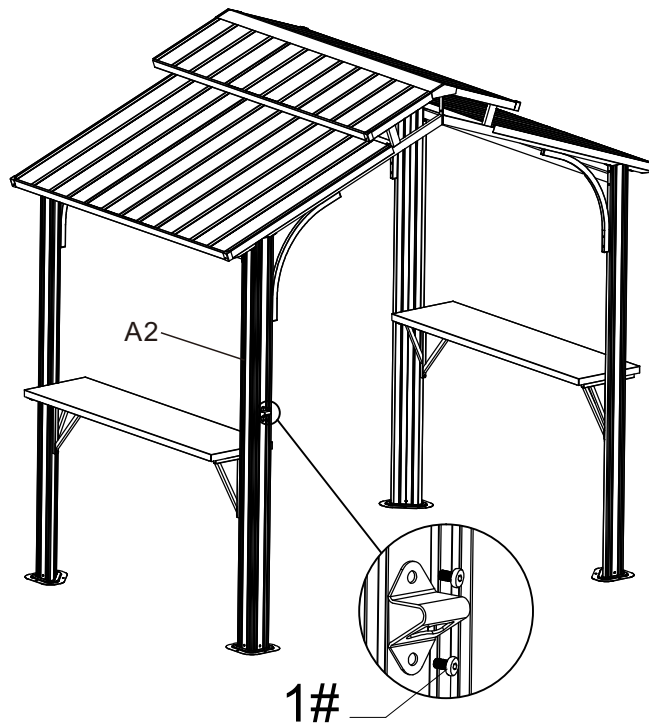



15# (x8)

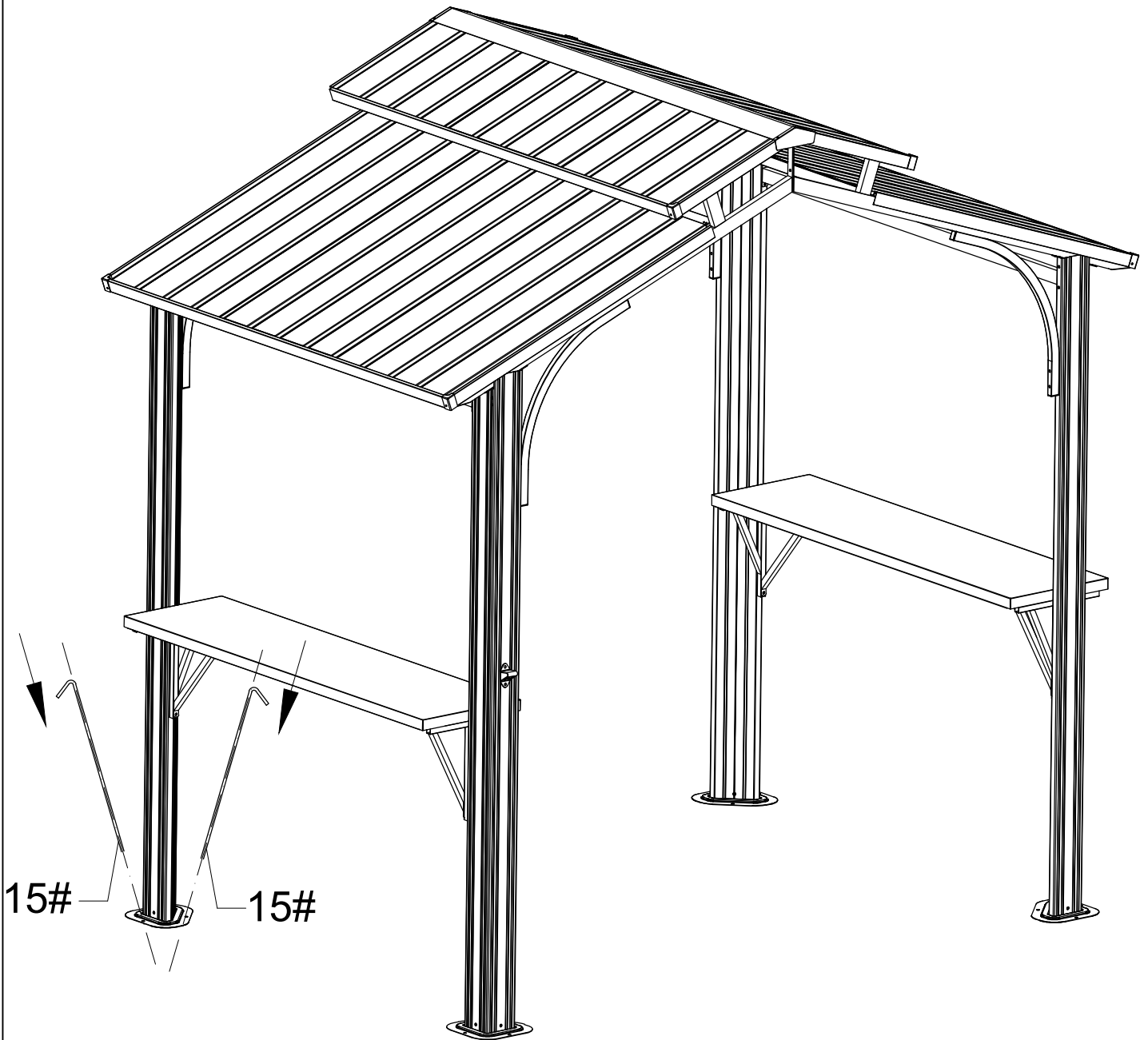

You can secure each base with 2 Post anchor to the soft ground as a temporary use.

⚠ The anchor can not be used as expansion bolts which can stand against the strong wind.