

Gourmet Cart
Charrette de cuisine
Carreton del cocinero

IMPORTANT!-IMPORTANT!-IMPORTANTE!

Please provide Control No. to ensure replacement parts properly fit unit on hand.
 Fournir N° de contrôle pour assurer que les pièces de rechange s'adaptent correctement à l'unité en question.
 Favor de proporcionar el numero de control para garantizar que las piezas de reemplazo ajuste correctame su producto.

 Name - Nom - Nombre

 Address - Adresse - Dirección

 City/State/Zip - Ville/Province/Code postal - Ciudad/Estado/Zona Postal

 Phone - Téléphone - Teléfono

 Email

Reason of replacement part(s) -Raison de(s) pièce(s) de remplacement - Razón del reemplazo la parte(s):

- Missing/Manquant/Ausente Not Fit/Ne rentre pas/No ajusta Provide Details/Fournis détails/Proporcionar detalles:
 Damaged/Endommagé/Dañado Other/Autre/Otro: _____

Parts List - Liste des pièces - Lista de partes

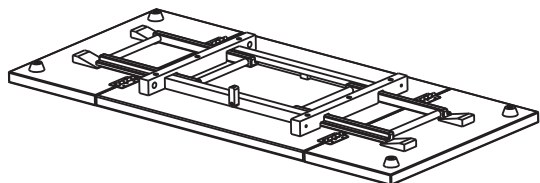

A	Top with Leaves Dessus avec abattants La tapa con hojas		
Quantity Quantité Cantidad	1	Missing Manquant Ausente	

B1	Front Left Post Montant avant gauche Poste izquierdo delantero		
Quantity Quantité Cantidad	1	Missing Manquant Ausente	

C1	Front Right Post Montant avant droit Poste derecho delantero		
Quantity Quantité Cantidad	1	Missing Manquant Ausente	

D1	Rear Right Post Montant arrière droit Poste derecho posterior		
Quantity Quantité Cantidad	1	Missing Manquant Ausente	

E1	Rear Left Post Montant arrière gauche Poste izquierdo posterior		
Quantity Quantité Cantidad	1	Missing Manquant Ausente	

Gourmet Cart
Charrette de cuisine
Carreton del cocinero

IMPORTANT!-IMPORTANT!- IMPORTANTE!

Please provide Control No. to ensure replacement parts properly fit unit on hand.

Fournir N° de contrôle pour assurer que les pièces de rechange s'adaptent correctement à l'unité en question.

Favor de proporcionar el numero de control para garantizar que las piezas de reemplazo ajuste correctame su producto

Name - Nom - Nombre

Address - Adresse - Dirección

City/State/Zip - Ville/Province/Code postal - Ciudad/Estado/Zona Postal

Phone - Téléphone - Teléfono

Email

Reason of replacement part(s) - Raison de(s) pièce(s) de remplacement -

- Razón del reemplazo la parte(s): Missing/Manquant/Ausente
 Damaged/Endommagé/Dañado
 Not Fit/Ne rentre pas/No ajusta
 Other/Autre/Otro:

Provide Details/Fournis détails/Proporcionar detalles:

Parts List - Liste des pièces - Lista de partes

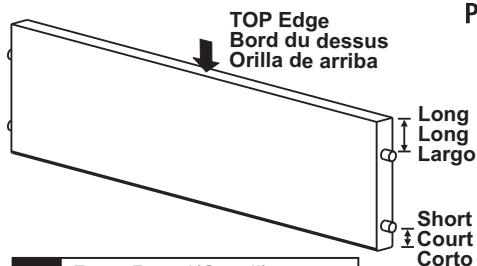

F	Rear Panel (Small) Panneau arrière (petit) Panel posterior (pequeño)		
Quantity Quantité Cantidad	1	Missing Manquant Ausente	

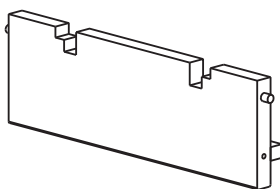

G	Side Panel Panneau latéral Panel del costado		
Quantity Quantité Cantidad	2	Missing Manquant Ausente	



H	Metal Rod Tige de métal Barra del metal		
Quantity Quantité Cantidad	1	Missing Manquant Ausente	

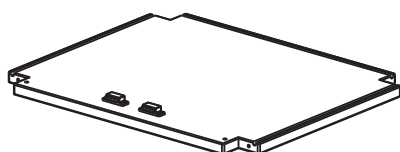

I	Middle Panel Panneau central Panel del medio		
Quantity Quantité Cantidad	1	Missing Manquant Ausente	

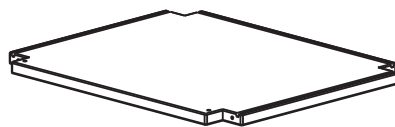

J	Bottom Panel Panneau inférieur Panel de abajo		
Quantity Quantité Cantidad	1	Missing Manquant Ausente	

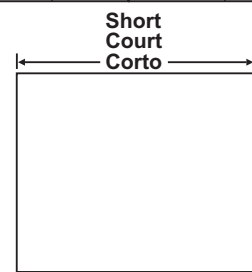

K	Side Panel Panneau latéral Panel del costado		
Quantity Quantité Cantidad	2	Missing Manquant Ausente	

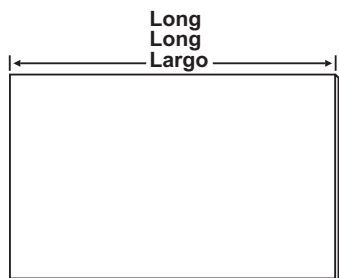

L	Back Panel Panneau arrière Panel Trasero		
Quantity Quantité Cantidad	1	Missing Manquant Ausente	

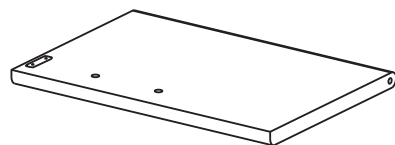

M	Left Door Porte gauche Puerta izquierdo		
Quantity Quantité Cantidad	1	Missing Manquant Ausente	

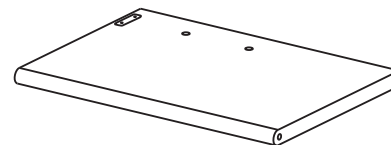

N	Right Door Porte droit Puerta derecho		
Quantity Quantité Cantidad	1	Missing Manquant Ausente	

Gourmet Cart
Charrette de cuisine
Carreton del cocinero

IMPORTANT!-IMPORTANT!- IMPORTANTE!

Please provide Control No. to ensure replacement parts properly fit unit on hand.

Fournir N° de contrôle pour assurer que les pièces de rechange s'adaptent correctement à l'unité en question.

Favor de proporcionar el numero de control para garantizar que las piezas de reemplazo ajuste correctame su producto

Name - Nom - Nombre

Address - Adresse - Dirección

City/State/Zip - Ville/Province/Code postal - Ciudad/Estado/Zona Postal

Phone - Téléphone - Teléfono

Email

Reason of replacement part(s) - Raison de(s) pièce(s) de remplacement -

Razón del reemplazo la parte(s): Missing/Manquant/Ausente

Damaged/Endommagé/Dañado

Not Fit/Ne rentre pas/No ajusta

Other/Autre/Otro:

Provide Details/Fournis détails/Proporcionar detalles:

Parts List - Liste des pièces - Lista de partes



P	Small Bolt* (Phillips) Petite cheville* (Phillips) Tornillo Pequeño* (Phillips)
Quantity Quantité Cantidad	6 <i>Missing Manquant Ausente</i>



R	Handle Poignée Manija
Quantity Quantité Cantidad	3 <i>Missing Manquant Ausente</i>



S	Metal Peg Cheville métallique Clavijas de metal
Quantity Quantité Cantidad	4 <i>Missing Manquant Ausente</i>

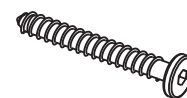

T	Hex Screw (Long) Hexagonal vis (long) Hexagonal tornillo (largo)
Quantity Quantité Cantidad	12 <i>Missing Manquant Ausente</i>

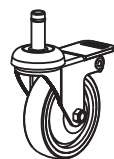

U1	Wheel with Lock Ruedecilla con bloqueos Roulette avec dispositif de blocage
Quantity Quantité Cantidad	2 <i>Missing Manquant Ausente</i>



V1	Wheel Roulette Ruedecilla
Quantity Quantité Cantidad	2 <i>Missing Manquant Ausente</i>



W	Wood Plug Chevilles en bois Tapón de madera
Quantity Quantité Cantidad	12 <i>Missing Manquant Ausente</i>



X	Hex Screw (Short) Hexagonal vis (Court) Hexagonal tornillo (Corto)
Quantity Quantité Cantidad	4 <i>Missing Manquant Ausente</i>



Y	Screw* (Phillips) Vis* (Phillips) Tornillo* (Phillips)
Quantity Quantité Cantidad	8 <i>Missing Manquant Ausente</i>

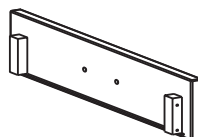

Z1	Front Panel (Drawer) Panneau avant (tiroir) Parte de enfrente (cajon)
Quantity Quantité Cantidad	1 <i>Missing Manquant Ausente</i>

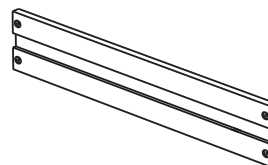

Z2	Side Panel (Drawer) Panneau latéraux (tiroir) Panel lateral (cajon)
Quantity Quantité Cantidad	2 <i>Missing Manquant Ausente</i>

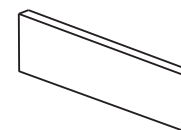

Z3	Back Panel (Drawer) Panneau arrière (tiroir) Parte de atrás (cajon)
Quantity Quantité Cantidad	1 <i>Missing Manquant Ausente</i>

Medium
Moyen
Medio

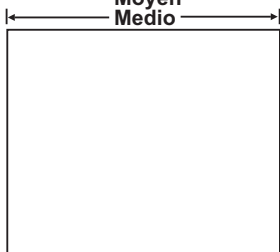

Z4	Bottom Board (Drawer) Conseil Inférieur (tiroir) Base de abajo (cajon)
Quantity Quantité Cantidad	1 <i>Missing Manquant Ausente</i>



	Hex Wrench Clé hexagonale Llave hexagonal
Quantity Quantité Cantidad	1 <i>Missing Manquant Ausente</i>

* Screw Driver is required and not included in the package.

* Un tournevis est nécessaire mais n'est pas inclus avec cet ensemble.

* Se requiere desarmador de cruz y no viene incluido.

Overall View: / Vue totale: / Vista total:

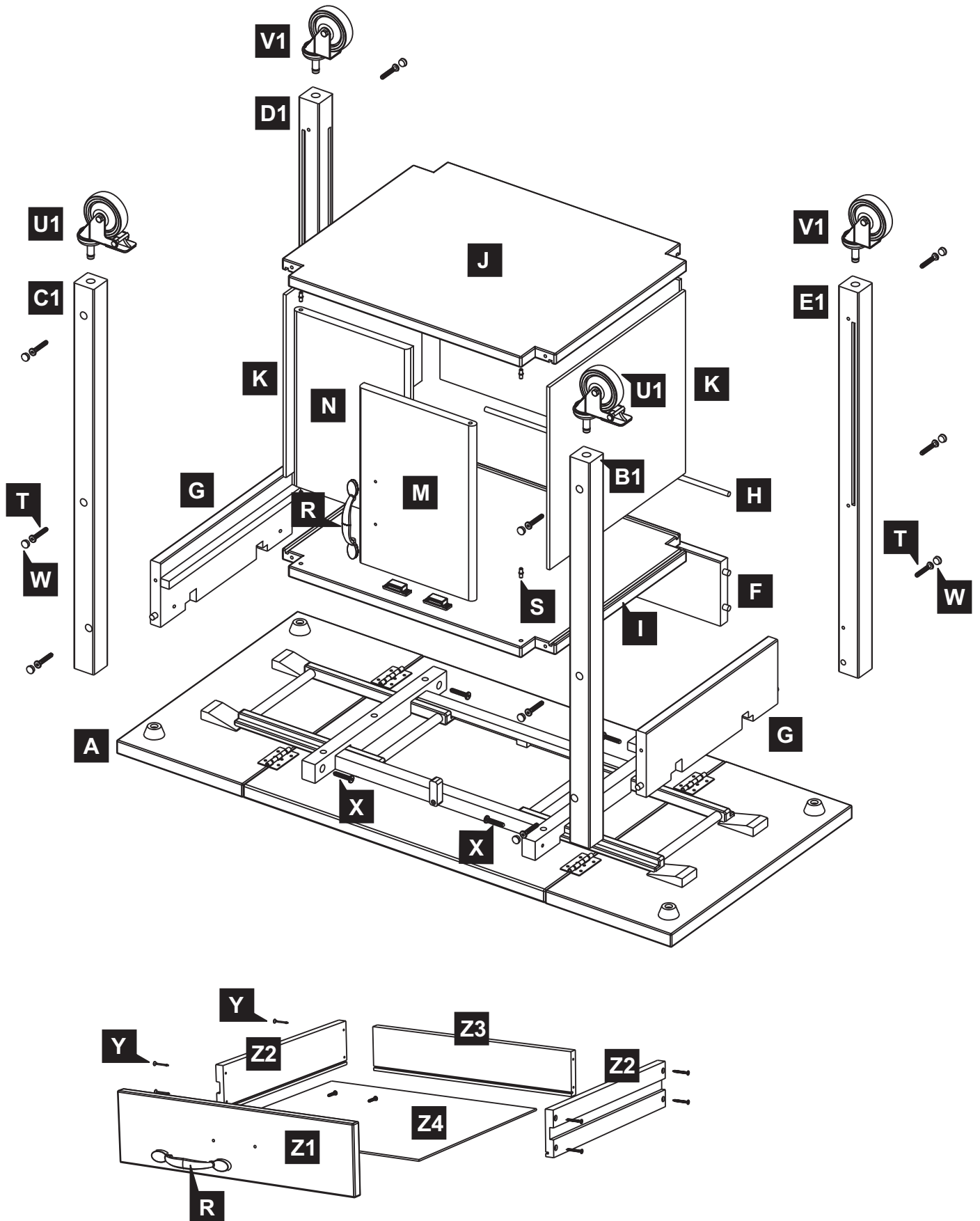

Assembly Instructions - Instructions d'assemblage - Instrucciones de ensamblaje

1

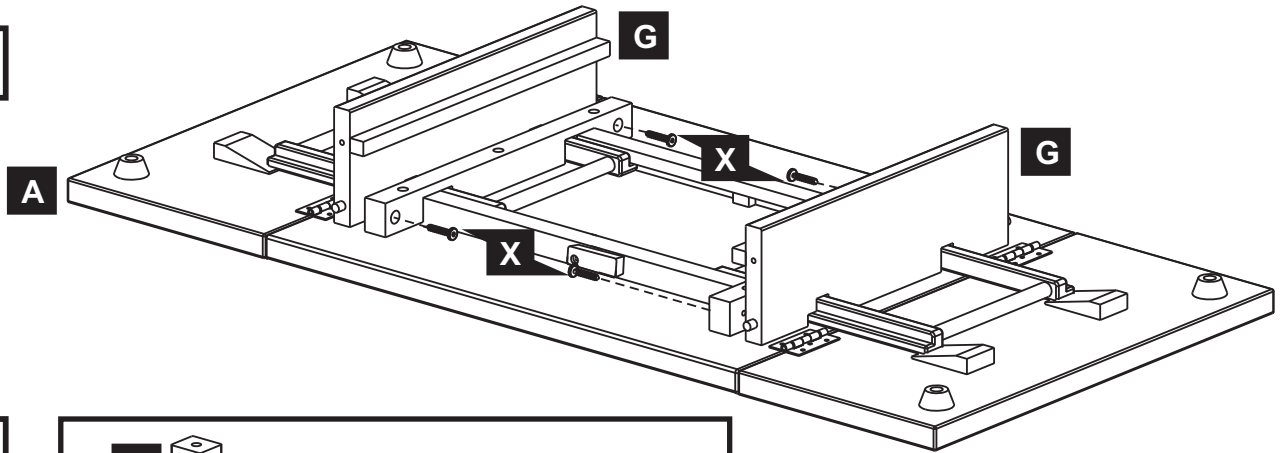

2

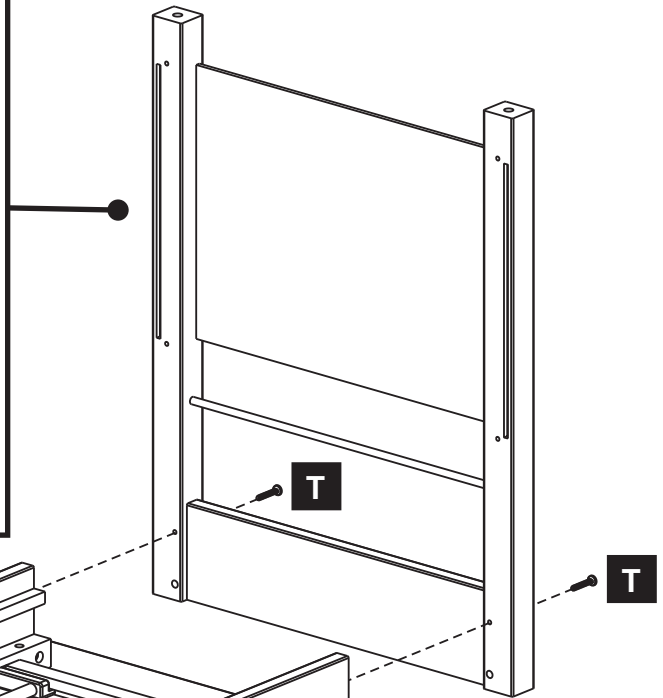
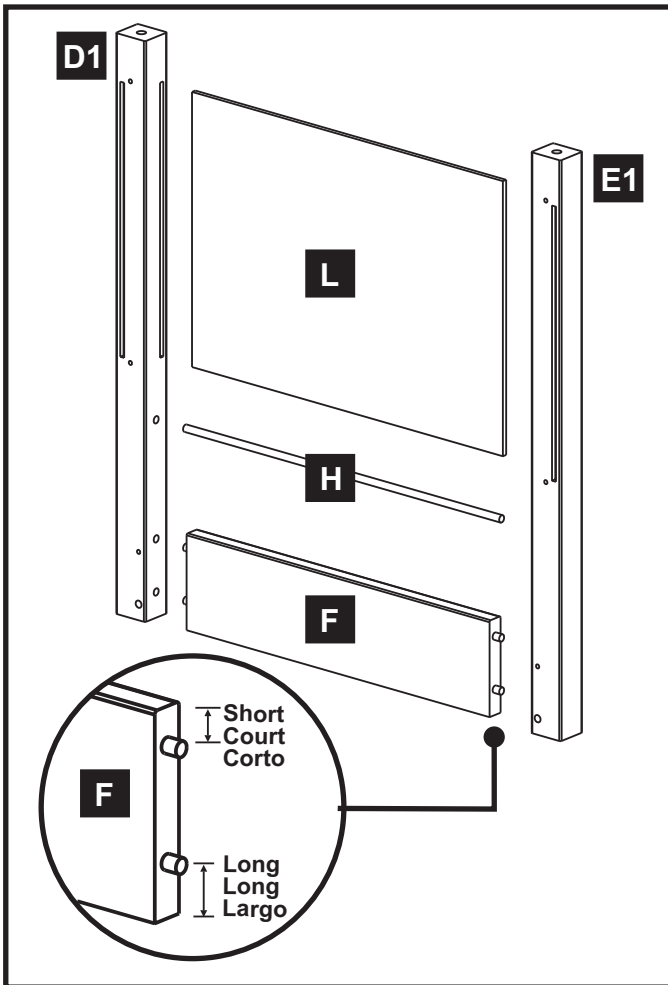

Drawer Stopper
Goujon pour le tiroir
Clavija para el Cajon

Front - Avant - Frente

ASSEMBLY
ASSEMBLAGE
ENSAMBLAJE



TWO PERSONS
DEUX PERSONNES
DOS PERSONAS

Assembly Instructions - Instructions d'assemblage - Instrucciones de ensamblaje

3

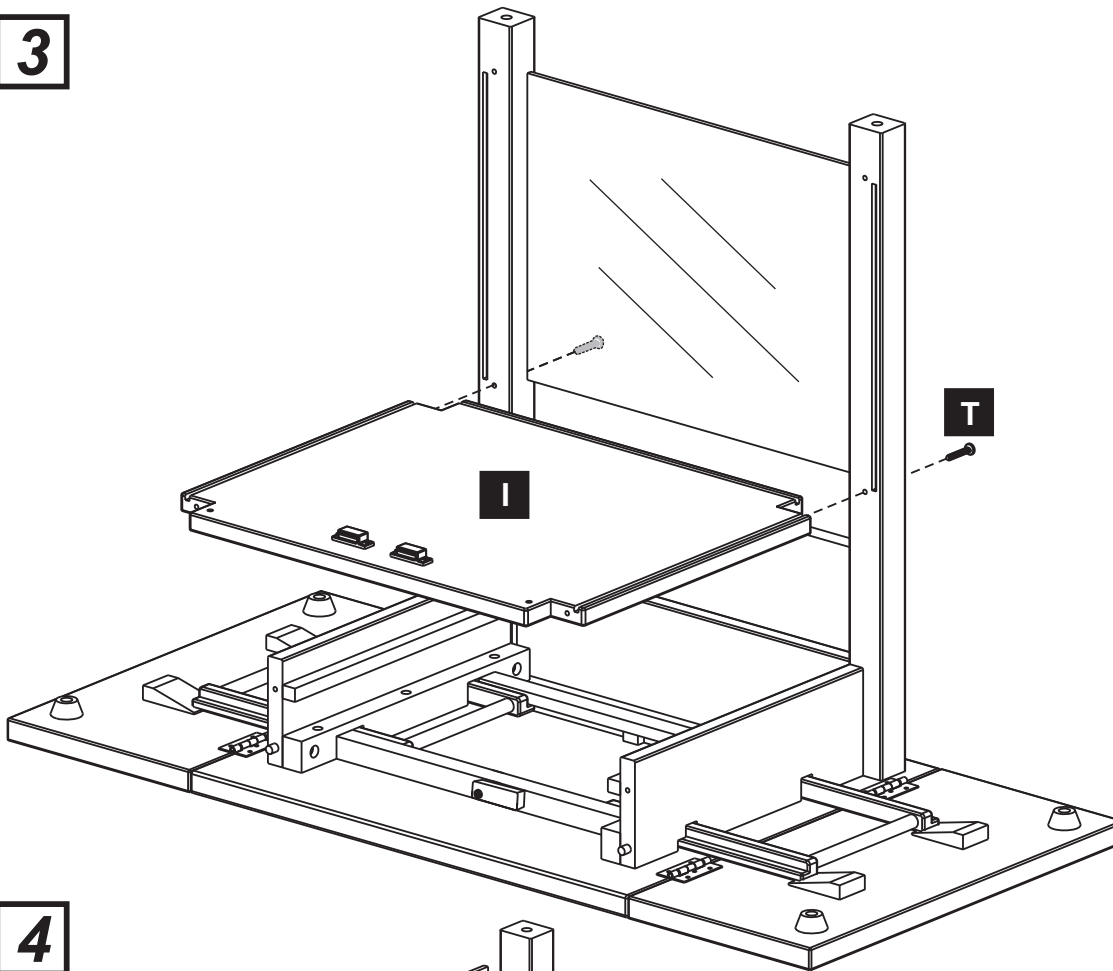

ASSEMBLY
ASSEMBLAGE
ENSAMBLAJE



TWO PERSONS
DEUX PERSONNES
DOS PERSONAS

Care instructions: Proper care and treatment are essential to preserve the natural beauty of this wood product. To clean wood surfaces, wipe with wet cloth and dry thoroughly. Use mild soap if necessary. Occasional mineral oil treatment will revitalize wood. Use good furniture oil and follow manufacturer's instruction for application. Avoid use of commercial waxes or polishes, glass cleaners or abrasive cleaning materials.

Instructions d'entretien: Il est très important de bien entretenir et de bien traiter ce produit en bois pour en préserver la beauté naturelle. Pour nettoyer les surfaces en bois, essuyez avec un linge humide et séchez à fond. Utilisez un savon doux au besoin. Un traitement occasionnel avec de l'huile minérale revitalisera le bois. Utilisez une bonne huile à meuble et suivez les instructions du fabricant pour l'application. Évitez d'utiliser des cires ou produits à polir de type commercial, des produits pour vitres ou des matériaux de nettoyage abrasifs.

Instrucciones para el cuidado:

Cuidado y trato apropiado son esenciales para preservar la belleza natural de este producto de madera. Para limpiar las superficies de madera, frótelas con algo húmedo y séquelas bien. Use un jabón suave si es necesario. Un tratamiento ocasional con aceite mineral revitalizará la madera. Use un buen aceite para muebles y siga las instrucciones del fabricante para aplicarlo. Evite el uso de ceras o pulidores comerciales, limpiadores de cristales o materiales abrasivos.

4

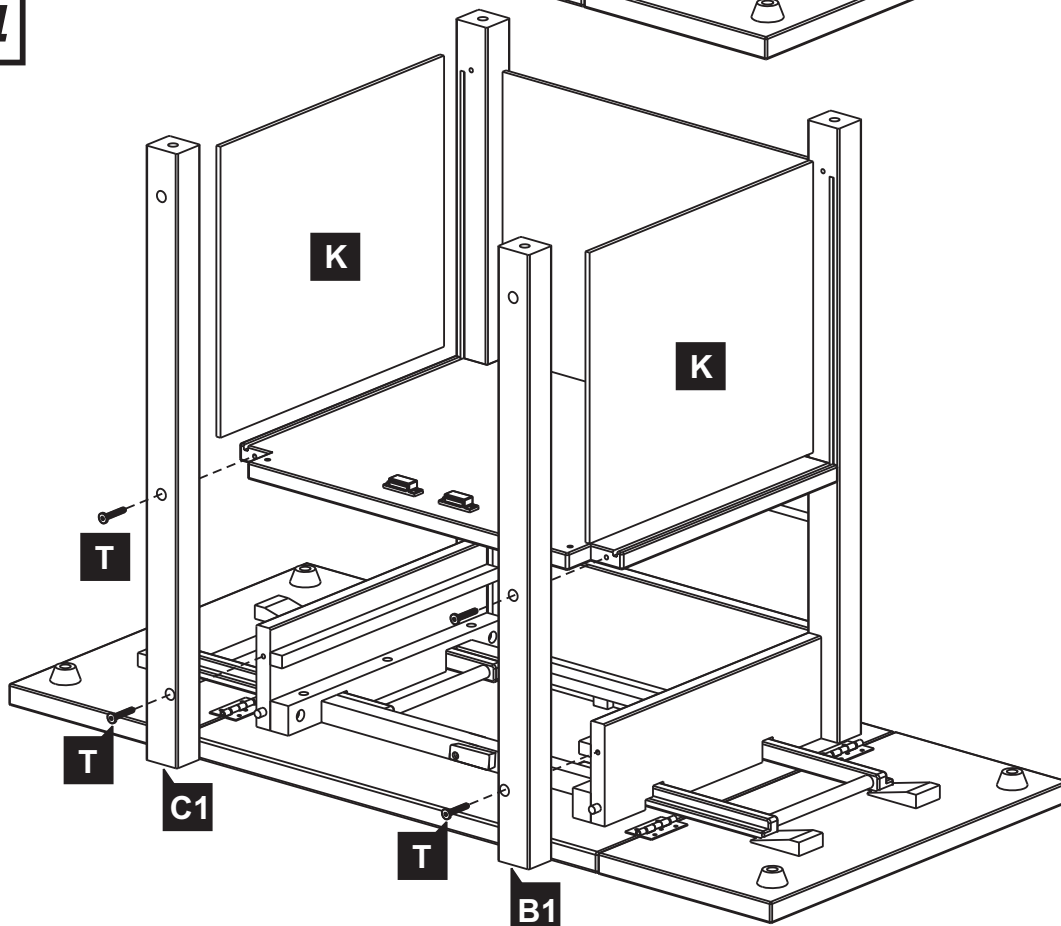

Assembly Instructions - Instructions d'assemblage - Instrucciones de ensamblaje

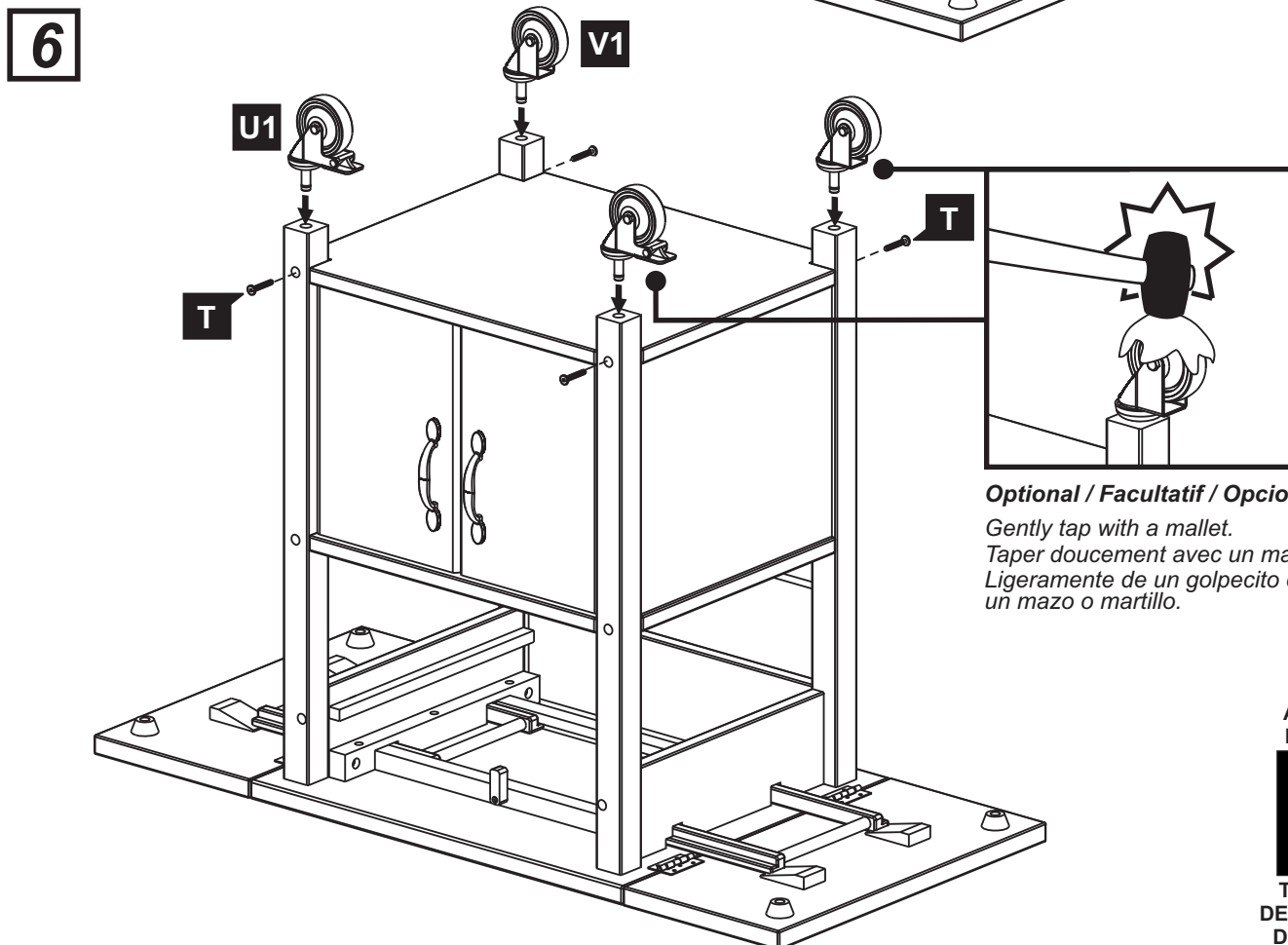
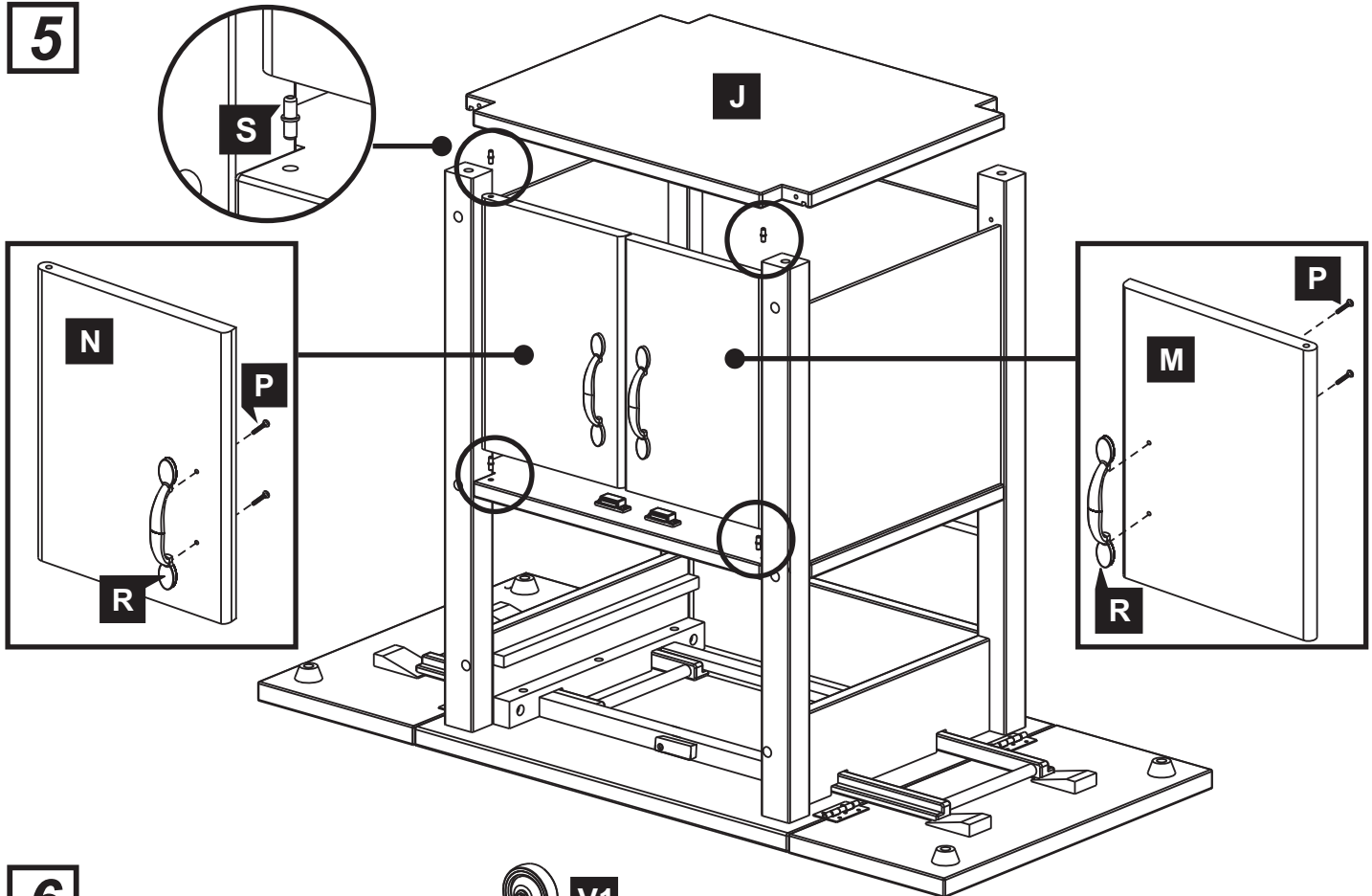

ASSEMBLY
 ASSEMBLAGE
 ENSAMBLAJE

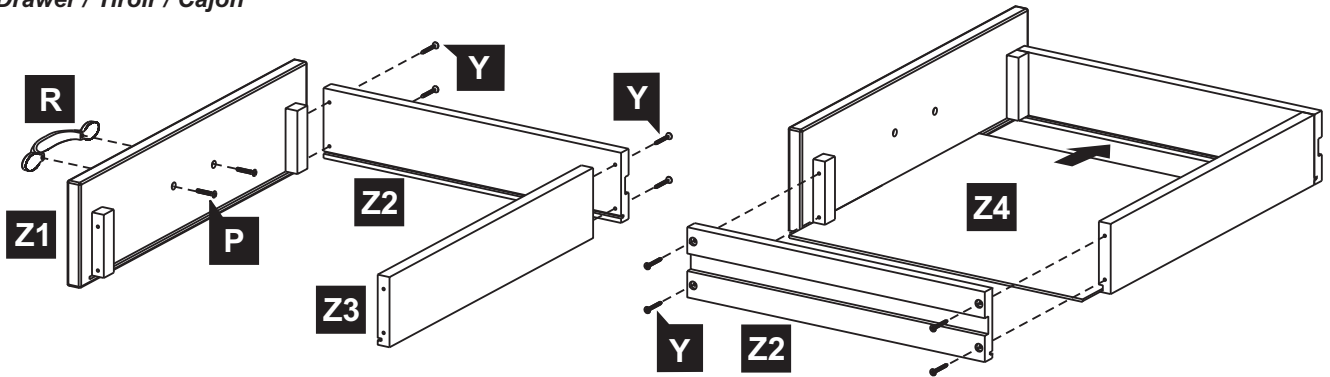

TWO PERSONS
 DEUX PERSONNES
 DOS PERSONAS

Assembly Instructions - Instructions d'assemblage - Instrucciones de ensamblaje
7
Drawer / Tiroir / Cajon

**Drawer Stopper / Tiroir bouchon
- Clavija para el Cajon**

Flip Stopper **DOWN** to **LOCK**.
Tourner la butée vers le **BAS** pour verrouiller.
Volteé el pasador de madera para abajo para cerrar.

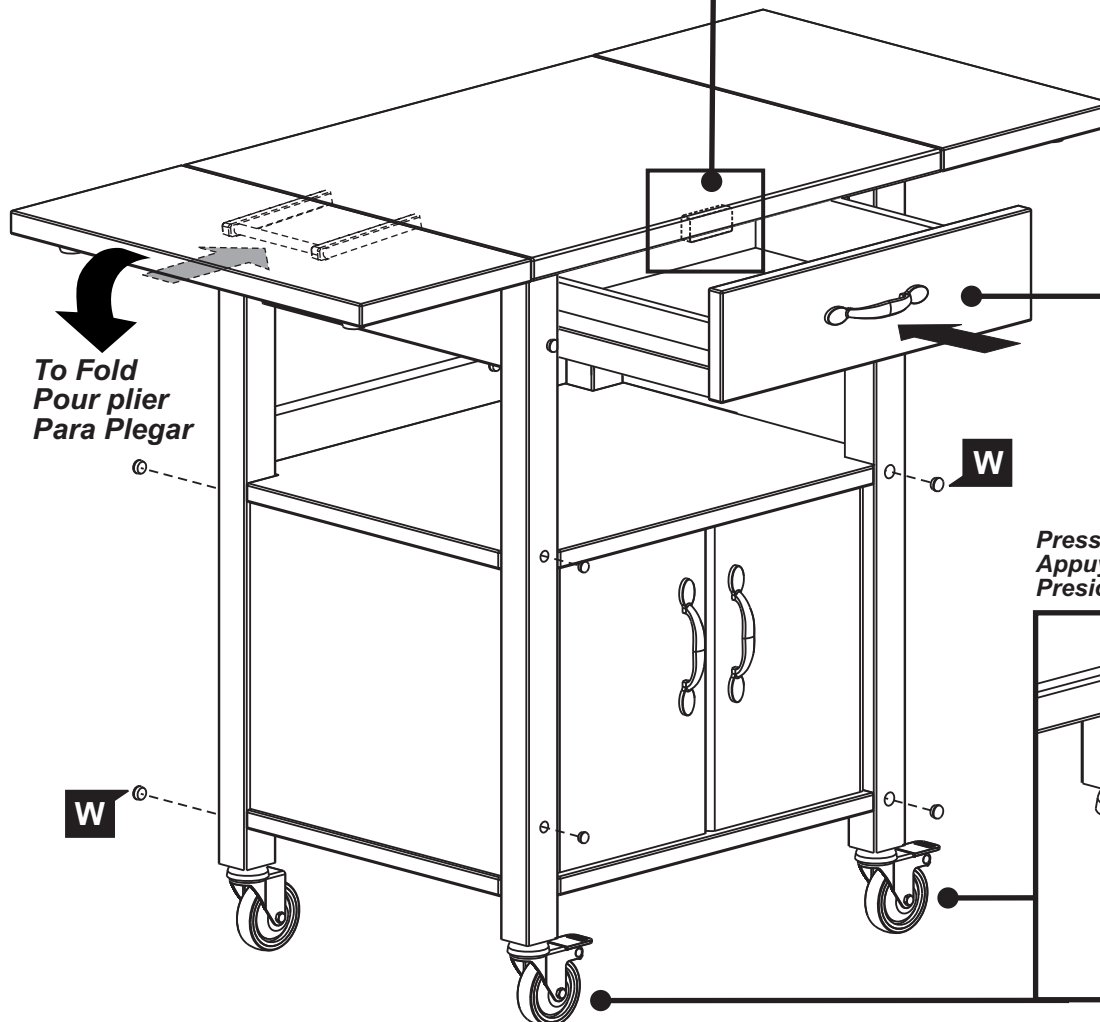
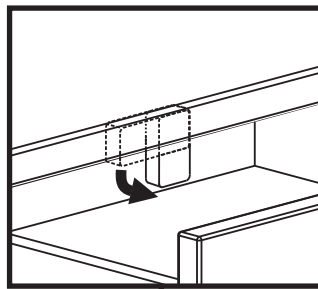
Flip Stopper **UP** to **UNLOCK**.
Tourner la butée vers le **HAUT** pour déverrouiller.
Volteé el pasador de madera para arriba para abrir.



**To Fold
Pour plier
Para Plegar**

**Press to lock
Appuyer pour verrouiller
Presione hacia abajo para trabar**