

# ASSEMBLY INSTRUCTION

**N719P220547**

**N719P220548**

---

---

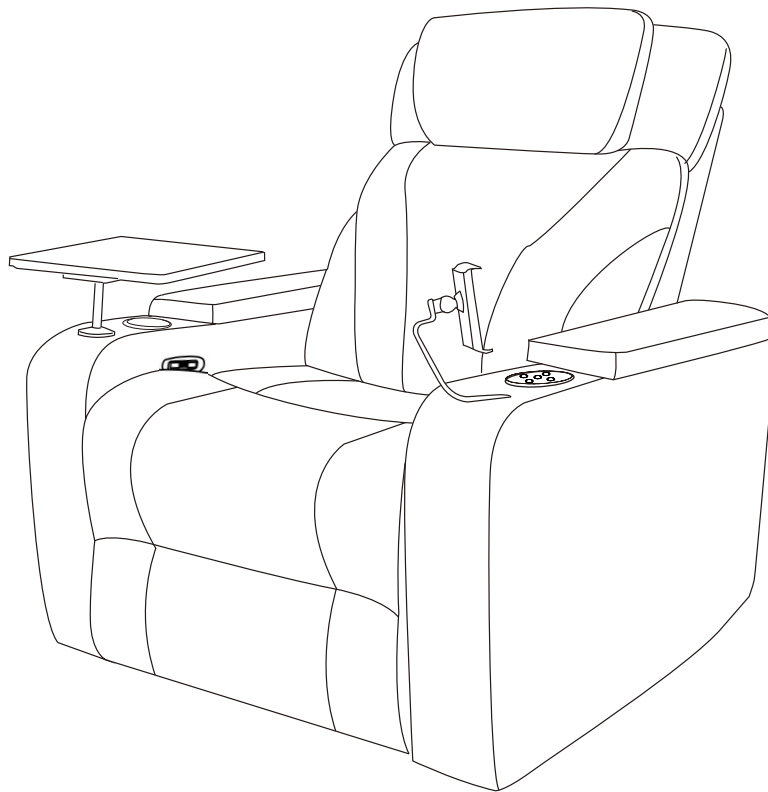

## Power Recliner

The chair set is delivered with **2 boxes**. We recommend assembling the set after you receive all the boxes.

---

# COMPONENTS

N719P220547

A\*1

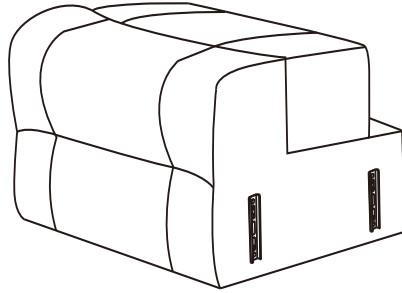

1 PC

N719P220548

B\*1

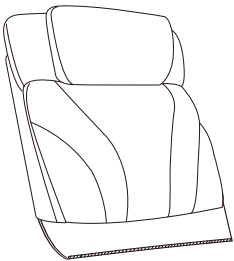

1 PC

C\*1

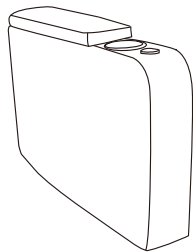

1 PC

D\*1

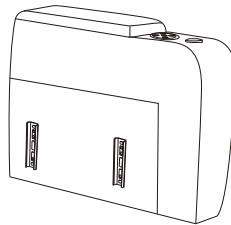

1 PC

E\*1

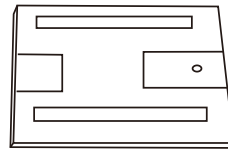

1 PC

F\*1

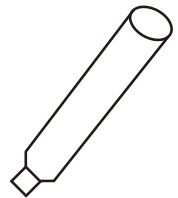

1 PC

G\*1



1 PC

H\*1

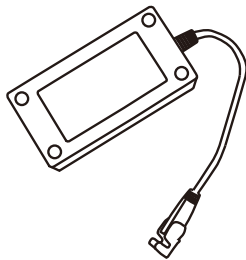

1 PC

I\*1

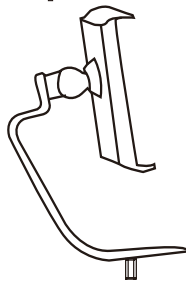

1 PC

J\*1

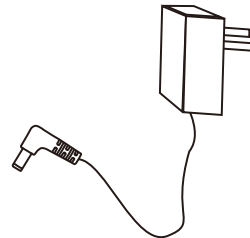

1 PC

# ASSEMBLY STEPS

## STEP 1

Take out the tray table (E) & shank (F) from the left arm (C).

Take out the holder (I), transformer (H) & wire plug (G) from the right arm (D).

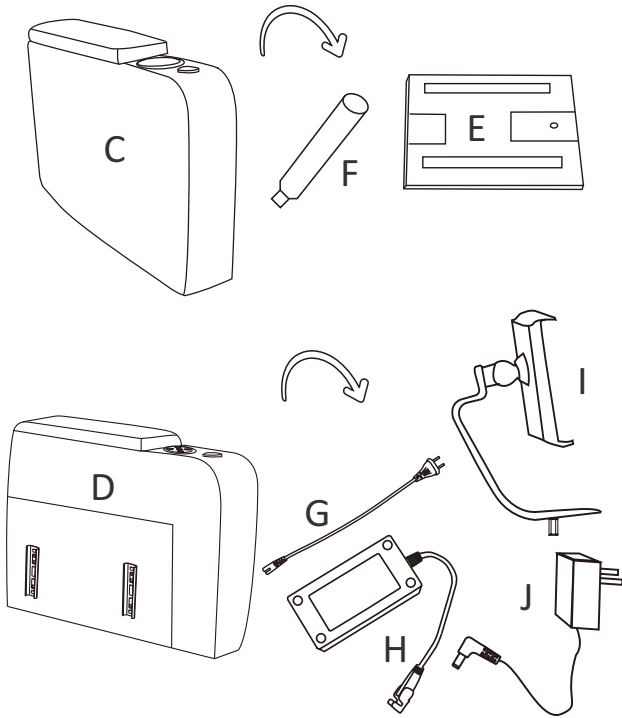

## STEP 2

Attach arm (C&D) to seat (A) by aligning the metal grooves on arm to brackets on sides of the seat (A) as shown.

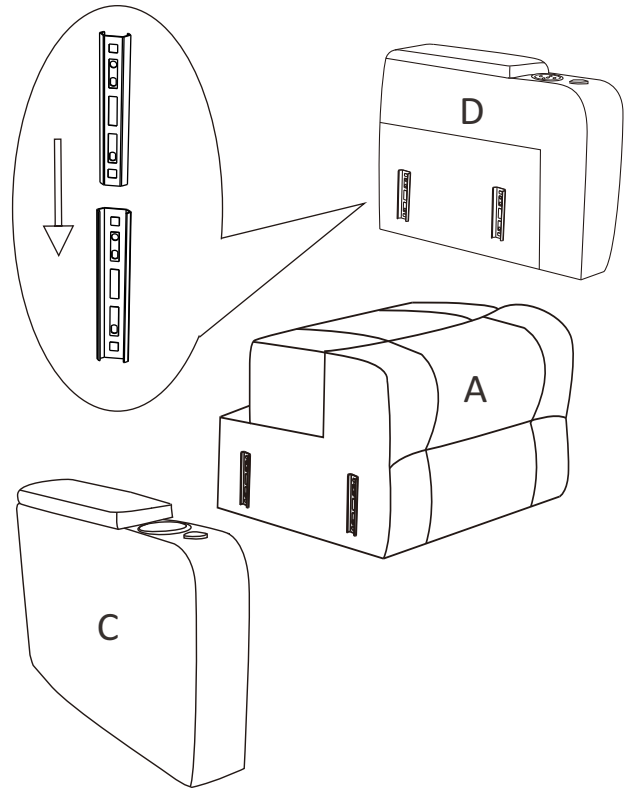

## STEP 3

Ensure the backrest (B) slides down fully over the brackets on the seat (A).

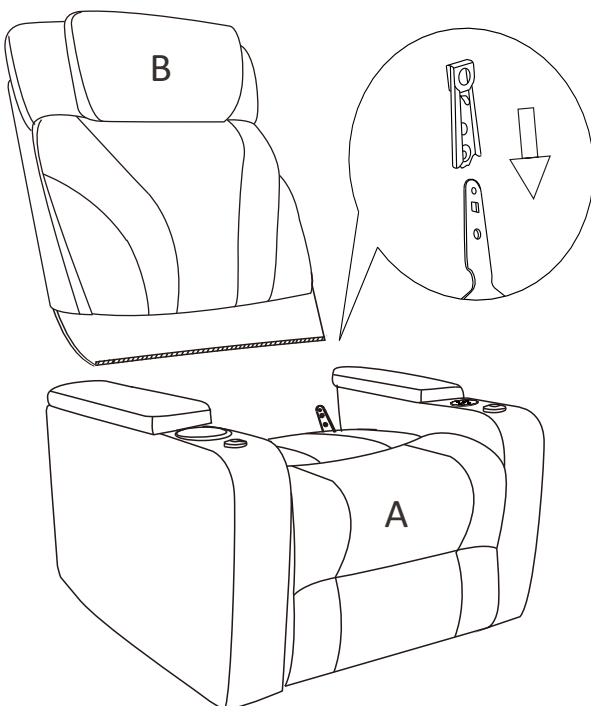

## STEP 4

- ① Connect this wire of the light strip (L match L).
- ② Connect this wire of the bluetooth speaker (S match S).
- ③&④ Attach the transformer (H) to the plug on the back of seat (A).
- ⑤ Connect the transformer (H) with the wire plug (G) and insert the wire plug into a wall outlet for power.
- ⑥ Connect this wire of the bluetooth speaker and insert the power adapter (J) into a wall outlet for power.

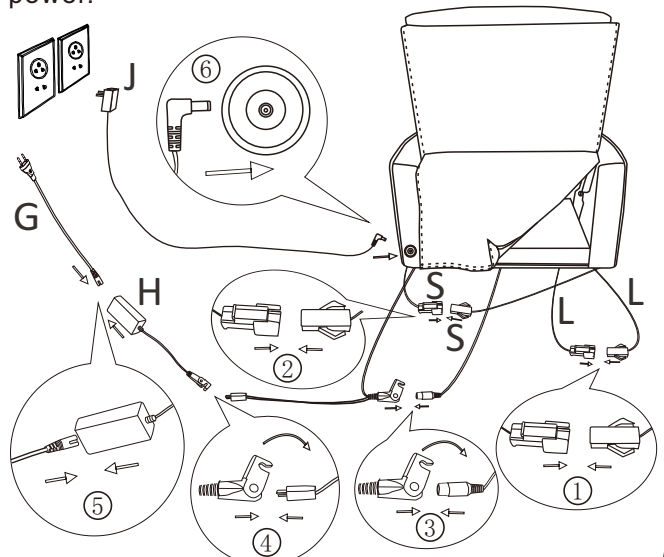

# ASSEMBLY STEPS

## STEP 5

Tighten the shank (F) onto the right arm, put the tray table (E) on the shank (F). Put the holder (I) onto the left arm.

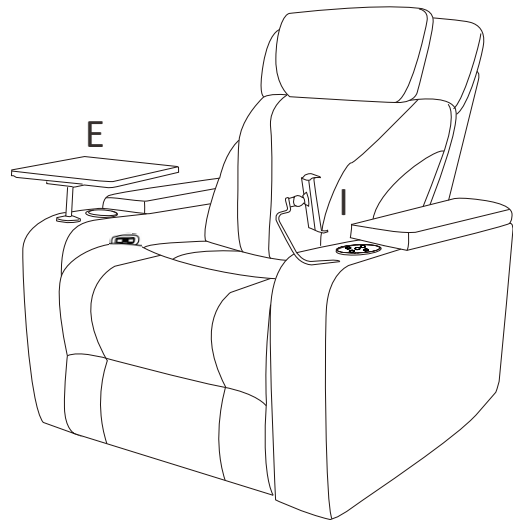
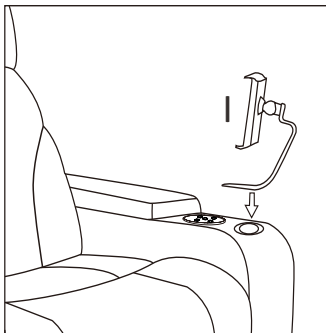
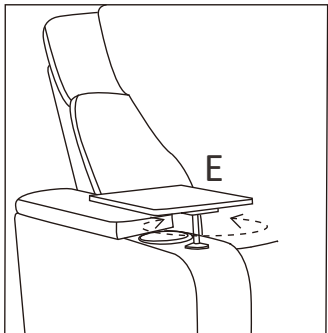
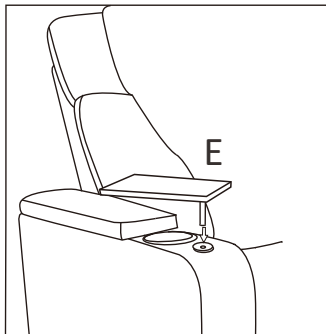
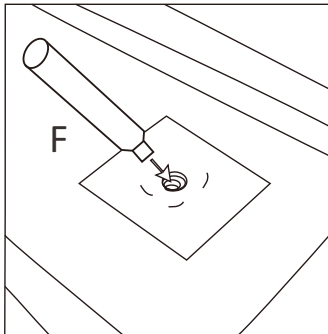

## STEP 6

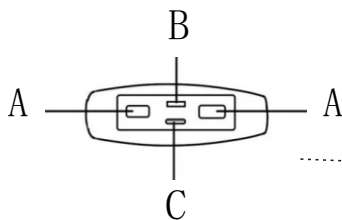

Press the A button to reline the sofa  
Press the B button to control the light  
C button is used to connect USB

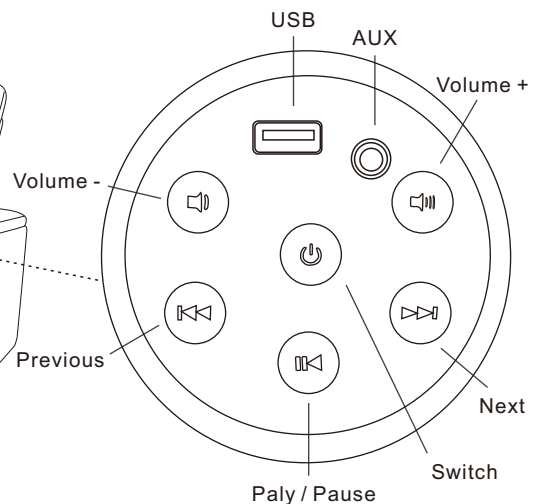
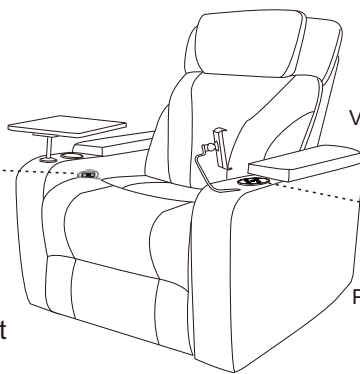

## STEP 7

### How to Disassemble

Please find a strong tool to prod the small piece of metal grooves, then the backrest will be pulled out. The tool is not included.

