

ASSEMBLY INSTRUCTIONS

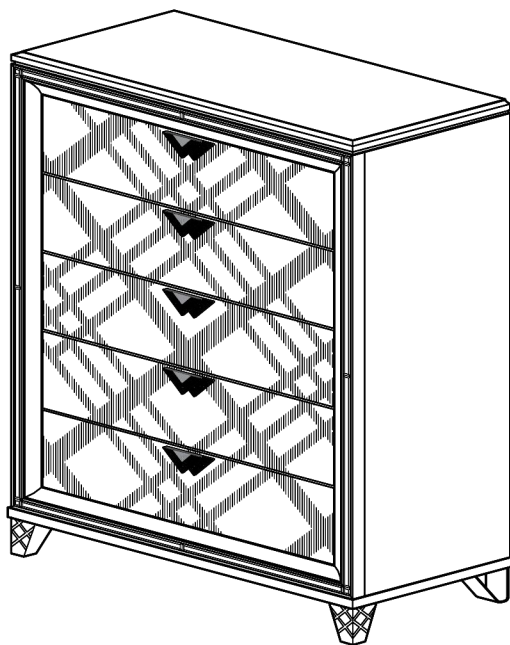

TOOLS REQUIRED

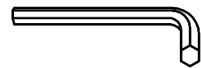

Allen Wrench

(Included)



Phillips
Screwdriver

(Not Included)



2 - People
Recommended

ASSEMBLY RATING



EASY —————> DIFFICULT

The Assembly Rating is a 5-point system showing the level of effort needed to assemble a specific product.



CHECK BEFORE STARTING

Are you missing anything?

Double-check all parts, hardware and accessories listed on Page 6 are accounted for.

Should we send any replacements?

Are there any irregularities or flaws in the parts? We can send replacements!

Check out our Quick Tips!

We recommend reviewing the pre-assembly handouts. Even experts need a refresher now and then!

Prep Time!

Please review the assembly instructions and all diagrams prior to assembling. Arrange parts as recommended on Page 7 and group identical hardware together to make assembling easier.

PRE ASSEMBLY INTRODUCTION

We understand building ready-to-assemble furniture can be a challenging experience for some. To help avoid confusion, we have provided some helpful tips that may speed up the process.

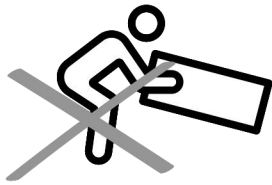

Teamwork

ALWAYS have at least two people to help with transporting and assembling the product to avoid potential injury and/or damage.

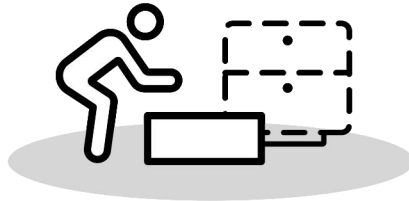
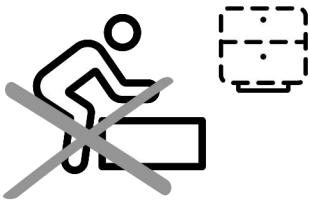

Suitable Location

Assembling near the area of the intended location is highly recommended.



Sufficient Space

Make sure you have enough space to move around during the assembly.

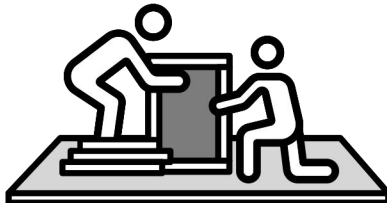

Avoid Scratches

Use cardboard, blankets or a carpeted area while assembling furniture to prevent scratches.

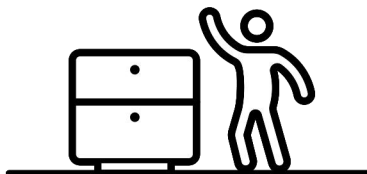
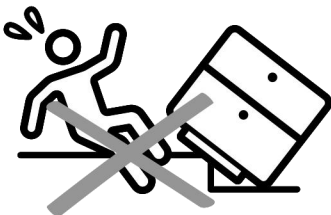

Flat Surface

Make sure the furniture rests on a flat and level surface with each leg evenly touching the floor.

ASSEMBLY AND CARE ADVICE



FAILURE TO FOLLOW THE GUIDELINES BELOW MAY RESULT IN INJURY AND/OR PROPERTY DAMAGE.



Position each part correctly and insert screws or bolts into their respective holes.



Use the appropriate hand tools or power tools for assembly. Select steps, such as tightening screws and/or bolts, may require hand tools to avoid causing damage during assembly.

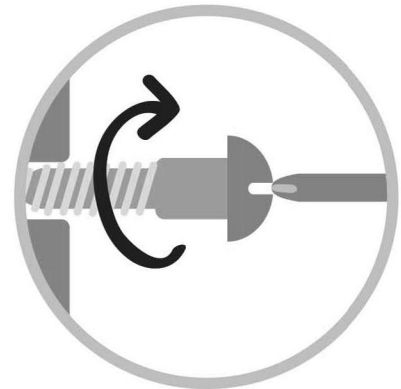

Turn clockwise to tighten and only tighten when step is completed or when instructed to do so.



Save the instructions and store any supplied tools for later maintenance.



After two weeks, check and tighten any loose hardware and repeat again every six months thereafter.

IT IS THE USER'S RESPONSIBILITY TO MAINTAIN THE FURNITURE. THE HARDWARE MAY LOOSEN OVER TIME AND MAY CAUSE THE FURNITURE TO BE WOBBLY AND UNABLE TO SUPPORT ITS INTENDED WEIGHT CAPACITY. THIS MAY LEAD TO COLLAPSE AND MAY CAUSE SERIOUS INJURY.

CHEST



- Please keep instructions for future reference.
- Check the quantity and irregularity of parts and hardware before you start.

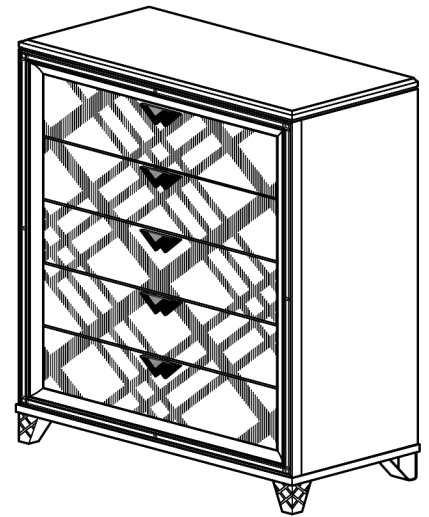

PARTS

#1 1pc

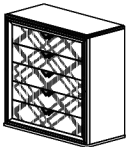

Chest

#2 2pcs



Acrylic Leg

#3 2pcs



Metal Leg

HARDWARE

#A 1pc



Allen Key

#B 4pcs



JCBC - M6 x 20mm

#C 4pcs



M6 Spring Washer

#D 4pcs



M6 Flat Washer

#E 1pc



Anti-tipping
Restraint Kit

ASSEMBLY INSTRUCTIONS

1

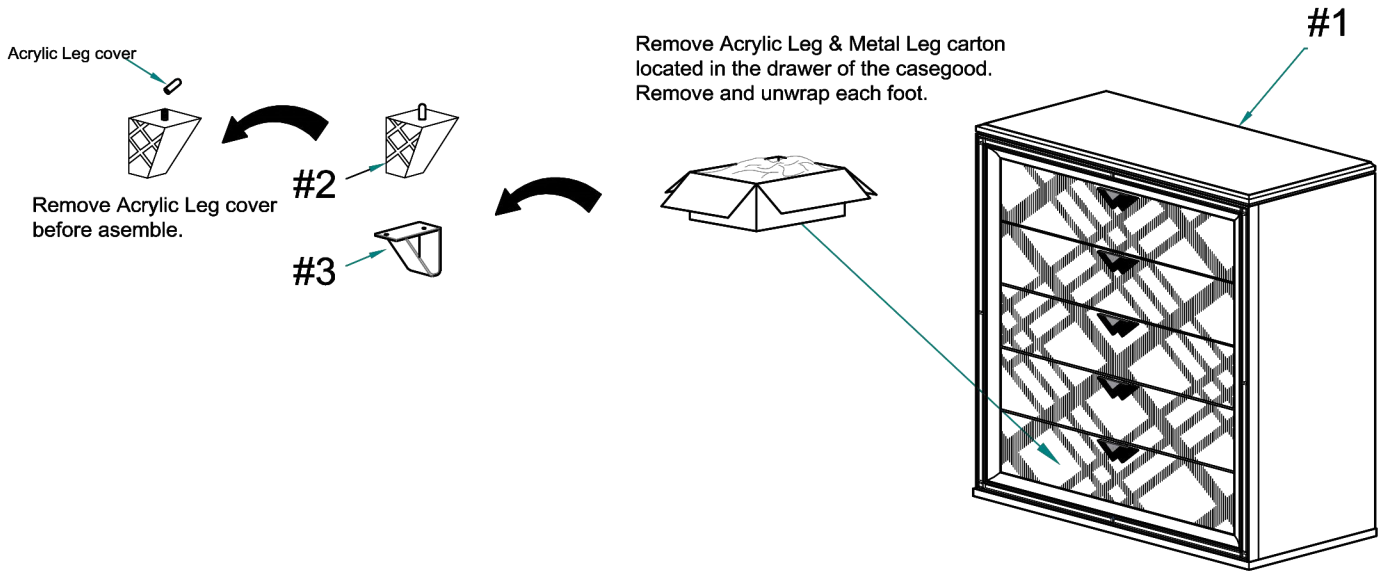

2

- Part (#1) x 1pc
- Part (#2) x 2pcs

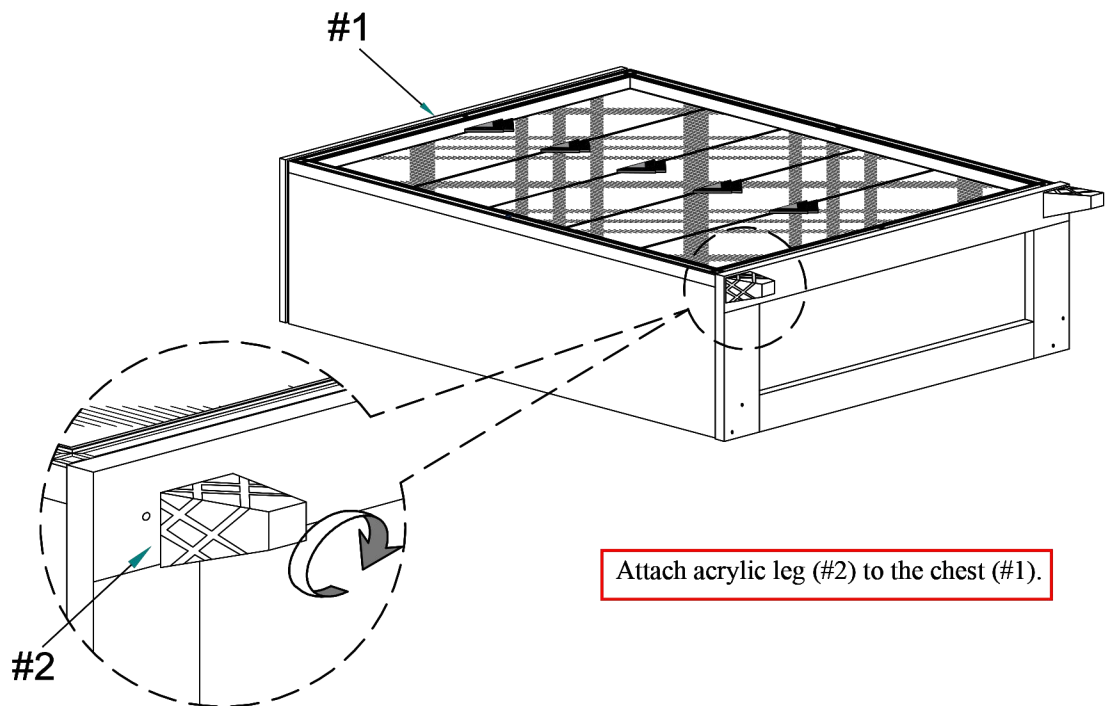

ASSEMBLY INSTRUCTIONS

3

Part (#1) x 1pc

Part (#3) x 2pcs

Hardware (#A) x 1pc

Hardware (#B) x 4pcs

Hardware (#C) x 4pcs

Hardware (#D) x 4pcs

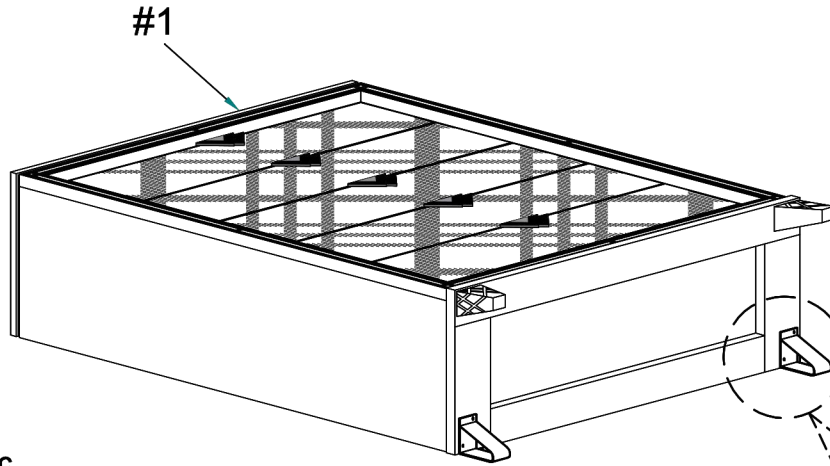

Align metal leg (#3) to the chest (#1), then secure by using bolts (#B) with washers (#C,D).

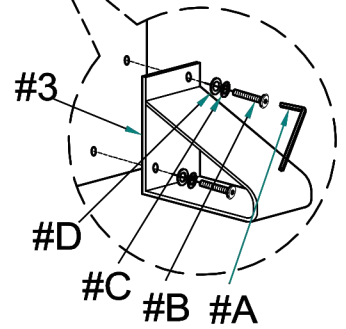

4

Part (#1) x 1pc

Hardware (#E) x 1pc

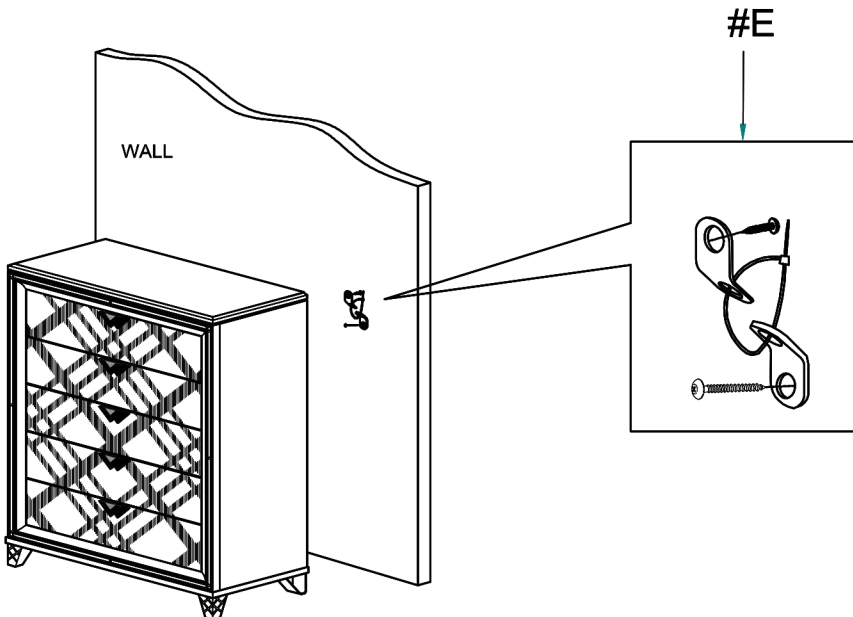

ASSEMBLY COMPLETED



Please ensure the furniture rests on an even and flat surface. If the product wobbles or feels loose, double-check all bolts and/or screws are properly tightened and secured.

✓ Keep this handy!

Please retain this instruction manual and any order-related information for future reference.

✓ Lift, don't drag!

To avoid damage to product please always LIFT the product when transporting or adjusting the placement.

ASSEMBLY INSTRUCTIONS

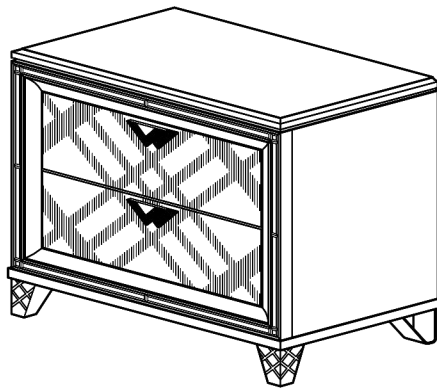

TOOLS REQUIRED



Allen Wrench

(Included)



**Phillips
Screwdriver**

(Not Included)



**2 - People
Recommended**

ASSEMBLY RATING



EASY —————> **DIFFICULT**

The Assembly Rating is a 5-point system showing the level of effort needed to assemble a specific product.



CHECK BEFORE STARTING

Are you missing anything?

Double-check all parts, hardware and accessories listed on Page 6 are accounted for.

Should we send any replacements?

Are there any irregularities or flaws in the parts? We can send replacements!

Check out our Quick Tips!

We recommend reviewing the pre-assembly handouts. Even experts need a refresher now and then!

Prep Time!

Please review the assembly instructions and all diagrams prior to assembling. Arrange parts as recommended on Page 7 and group identical hardware together to make assembling easier.

PRE ASSEMBLY INTRODUCTION

We understand building ready-to-assemble furniture can be a challenging experience for some. To help avoid confusion, we have provided some helpful tips that may speed up the process.

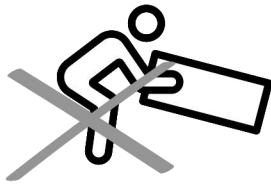

Teamwork

ALWAYS have at least two people to help with transporting and assembling the product to avoid potential injury and/or damage.

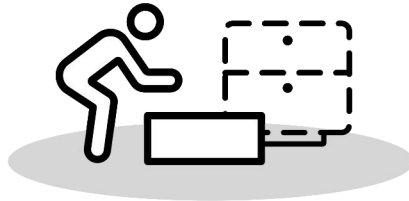
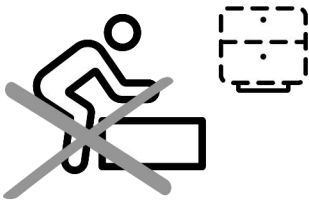

Suitable Location

Assembling near the area of the intended location is highly recommended.



Sufficient Space

Make sure you have enough space to move around during the assembly.

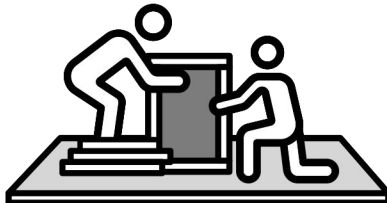

Avoid Scratches

Use cardboard, blankets or a carpeted area while assembling furniture to prevent scratches.

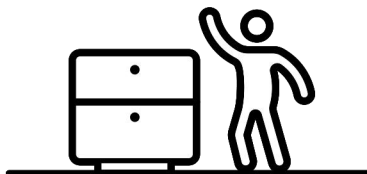
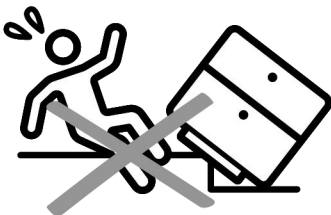

Flat Surface

Make sure the furniture rests on a flat and level surface with each leg evenly touching the floor.

ASSEMBLY AND CARE ADVICE



FAILURE TO FOLLOW THE GUIDELINES BELOW MAY RESULT IN INJURY AND/OR PROPERTY DAMAGE.



Position each part correctly and insert screws or bolts into their respective holes.

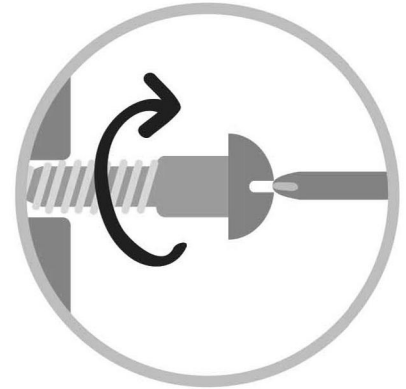

Turn clockwise to tighten and only tighten when step is completed or when instructed to do so.



Save the instructions and store any supplied tools for later maintenance.

Use the appropriate hand tools or power tools for assembly. Select steps, such as tightening screws and/or bolts, may require hand tools to avoid causing damage during assembly.



After two weeks, check and tighten any loose hardware and repeat again every six months thereafter.

IT IS THE USER'S RESPONSIBILITY TO MAINTAIN THE FURNITURE. THE HARDWARE MAY LOOSEN OVER TIME AND MAY CAUSE THE FURNITURE TO BE WOBBLY AND UNABLE TO SUPPORT ITS INTENDED WEIGHT CAPACITY. THIS MAY LEAD TO COLLAPSE AND MAY CAUSE SERIOUS INJURY.

NIGHT STAND



- Please keep instructions for future reference.
- Check the quantity and irregularity of parts and hardware before you start.

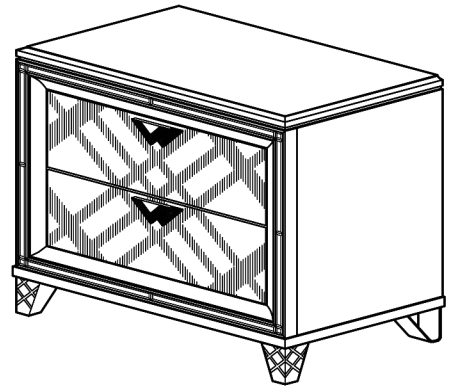

PARTS

#1 1pc

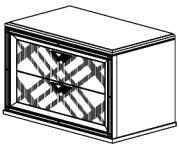

Night Stand

#2 2pcs



Acrylic Leg

#3 2pcs



Metal Leg

HARDWARE

#A 1pc



Allen Key

#B 4pcs



JCBC - M6 x 20mm

#C 4pcs



M6 Spring Washer

#D 4pcs



M6 Flat Washer

#E 1pc



USB Plug

#F 1pc



Anti-tipping
Restraint Kit

ASSEMBLY INSTRUCTIONS

1

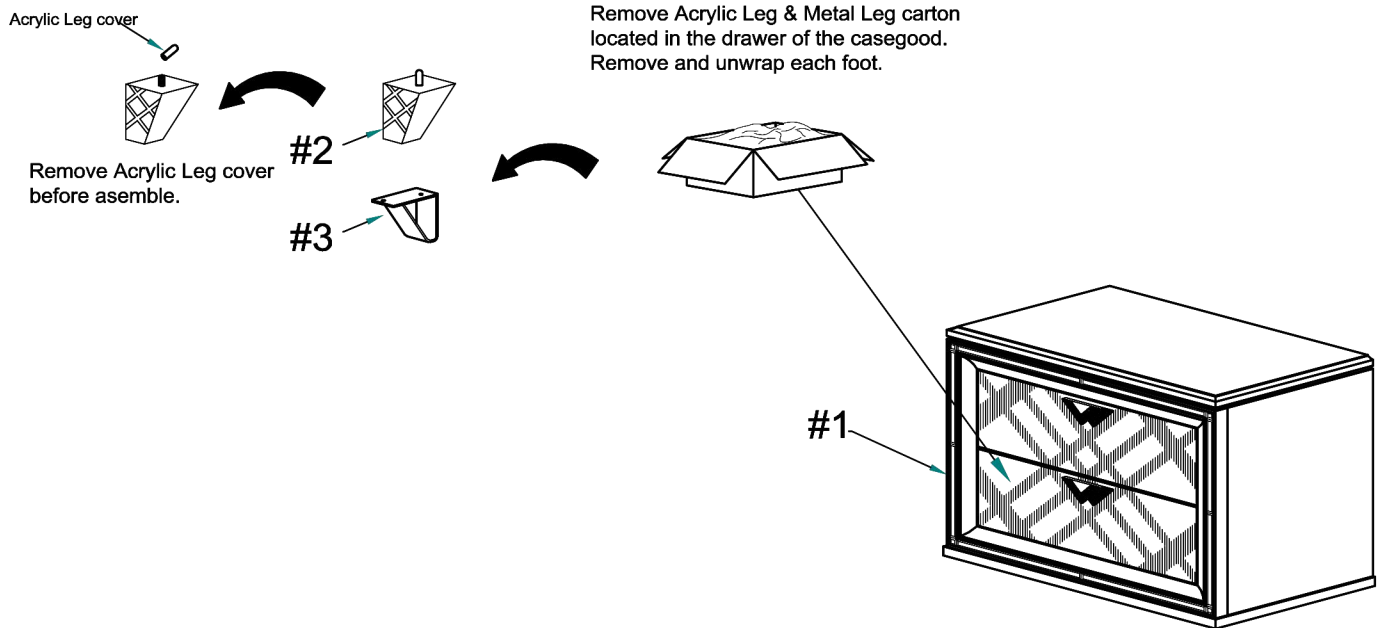

2

Part (#1) x 1pc

Part (#2) x 2pcs

Attach acrylic leg (#2) to the nightstand (#1).

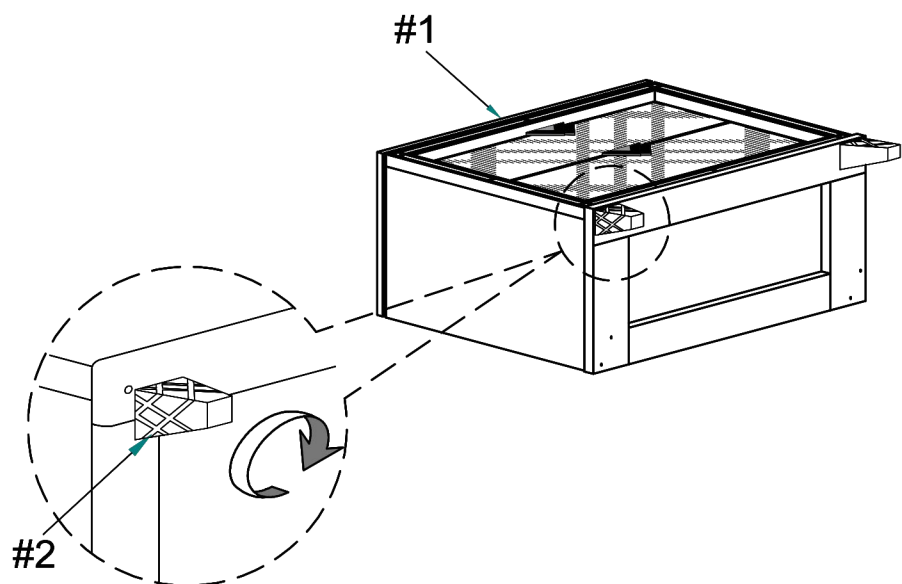

ASSEMBLY INSTRUCTIONS

3

Part (#1) x 1pc

Part (#3) x 2pcs

Hardware (#A) x 1pc

Hardware (#B) x 4pcs

Hardware (#C) x 4pcs

Hardware (#D) x 4pcs

Align metal legs (#3) to the nightstand (#1), then secure by using bolts (#B) with washers (#C,D).

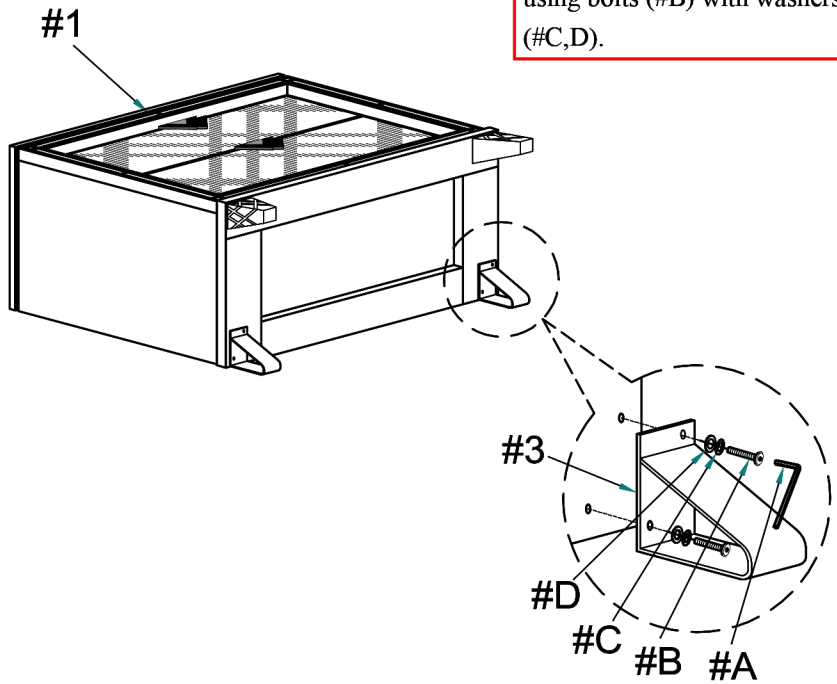

4

Part (#1) x 1pc

Hardware (#E) x 1pc

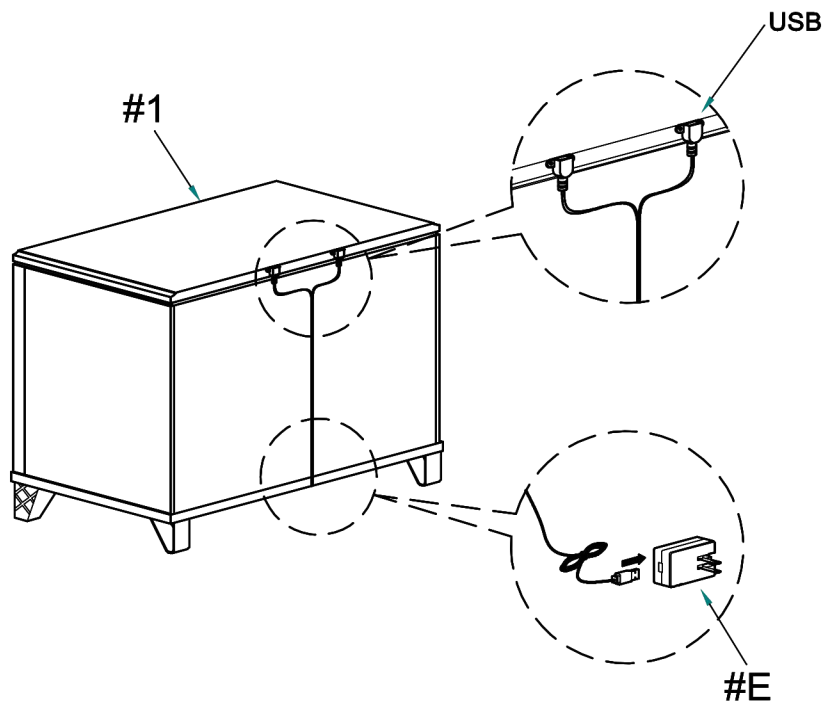

ASSEMBLY INSTRUCTIONS

5

Part #1 x 1pc

Hardware #F x 1pc

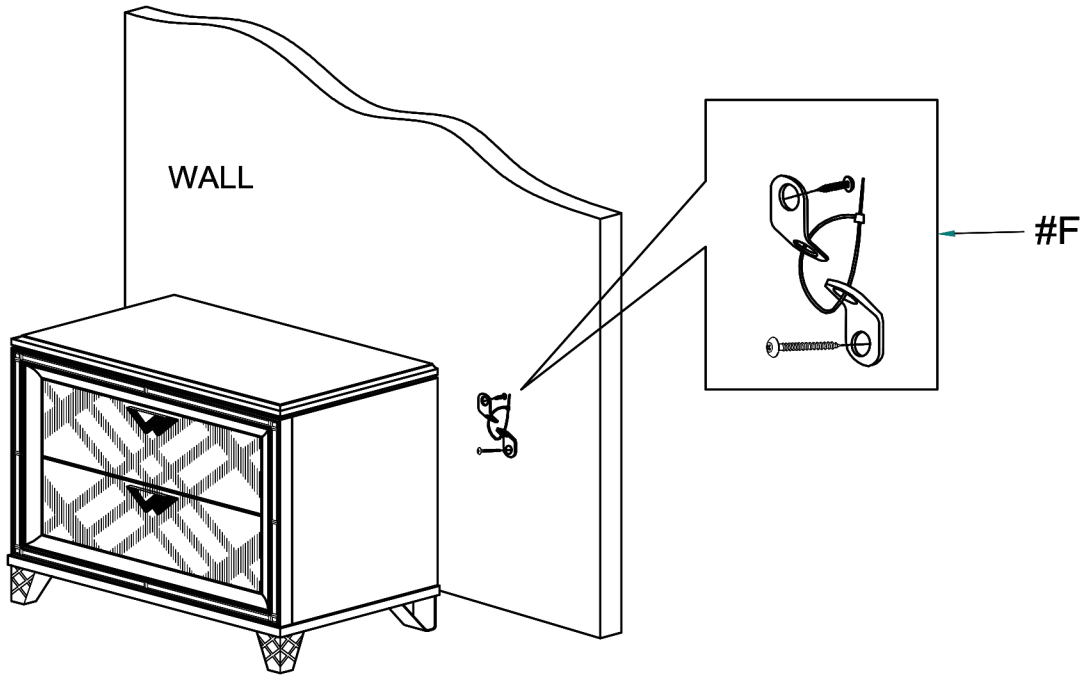

ASSEMBLY COMPLETED



Please ensure the furniture rests on an even and flat surface. If the product wobbles or feels loose, double-check all bolts and/or screws are properly tightened and secured.



Keep this handy!

Please retain this instruction manual and any order-related information for future reference.



Lift, don't drag!

To avoid damage to product please always LIFT the product when transporting or adjusting the placement.

ASSEMBLY INSTRUCTIONS

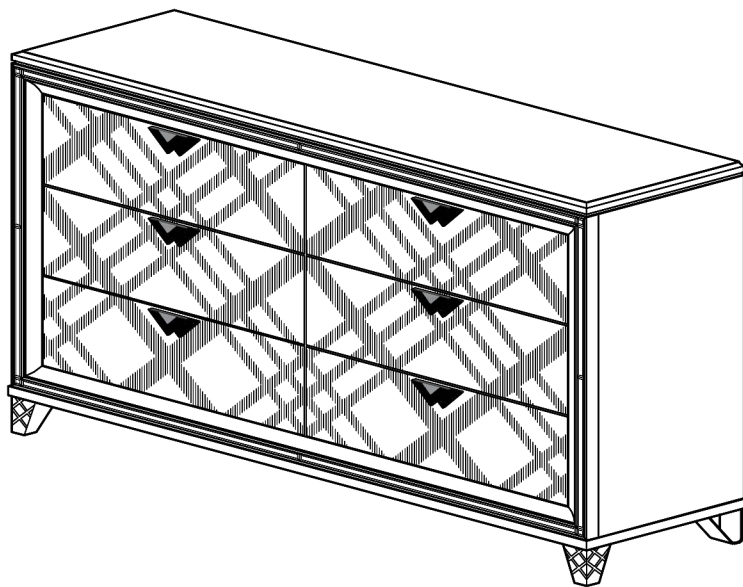

TOOLS REQUIRED



Allen Wrench

(Included)



Phillips
Screwdriver

(Not Included)



2 - People
Recommended

ASSEMBLY RATING



EASY —————> DIFFICULT

The Assembly Rating is a 5-point system showing the level of effort needed to assemble a specific product.



CHECK BEFORE STARTING

Are you missing anything?

Double-check all parts, hardware and accessories listed on Page 6 are accounted for.

Should we send any replacements?

Are there any irregularities or flaws in the parts? We can send replacements!

Check out our Quick Tips!

We recommend reviewing the pre-assembly handouts. Even experts need a refresher now and then!

Prep Time!

Please review the assembly instructions and all diagrams prior to assembling. Arrange parts as recommended on Page 7 and group identical hardware together to make assembling easier.

PRE ASSEMBLY INTRODUCTION

We understand building ready-to-assemble furniture can be a challenging experience for some. To help avoid confusion, we have provided some helpful tips that may speed up the process.

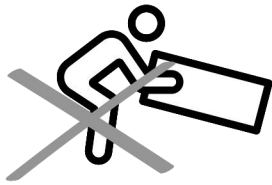

Teamwork

ALWAYS have at least two people to help with transporting and assembling the product to avoid potential injury and/or damage.

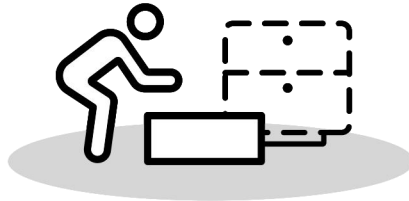
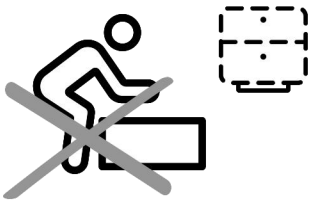

Suitable Location

Assembling near the area of the intended location is highly recommended.



Sufficient Space

Make sure you have enough space to move around during the assembly.

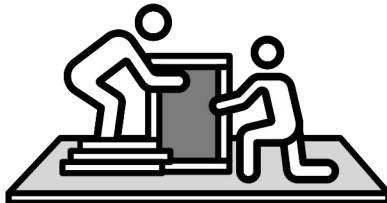

Avoid Scratches

Use cardboard, blankets or a carpeted area while assembling furniture to prevent scratches.

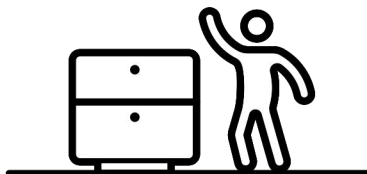
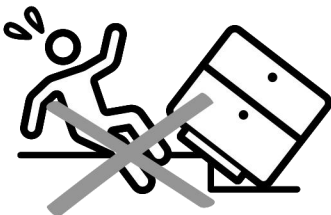

Flat Surface

Make sure the furniture rests on a flat and level surface with each leg evenly touching the floor.

ASSEMBLY AND CARE ADVICE



FAILURE TO FOLLOW THE GUIDELINES BELOW MAY RESULT IN INJURY AND/OR PROPERTY DAMAGE.



Position each part correctly and insert screws or bolts into their respective holes.

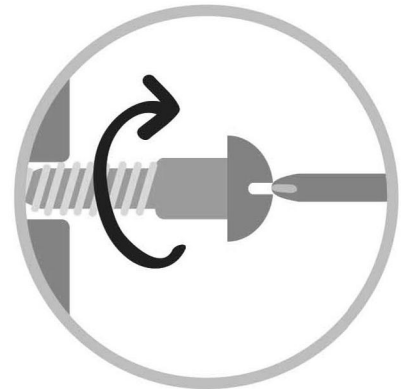

Turn clockwise to tighten and only tighten when step is completed or when instructed to do so.



Save the instructions and store any supplied tools for later maintenance.

Use the appropriate hand tools or power tools for assembly. Select steps, such as tightening screws and/or bolts, may require hand tools to avoid causing damage during assembly.



After two weeks, check and tighten any loose hardware and repeat again every six months thereafter.

IT IS THE USER'S RESPONSIBILITY TO MAINTAIN THE FURNITURE. THE HARDWARE MAY LOOSEN OVER TIME AND MAY CAUSE THE FURNITURE TO BE WOBBLY AND UNABLE TO SUPPORT ITS INTENDED WEIGHT CAPACITY. THIS MAY LEAD TO COLLAPSE AND MAY CAUSE SERIOUS INJURY.

DRESSER



- Please keep instructions for future reference.
- Check the quantity and irregularity of parts and hardware before you start.

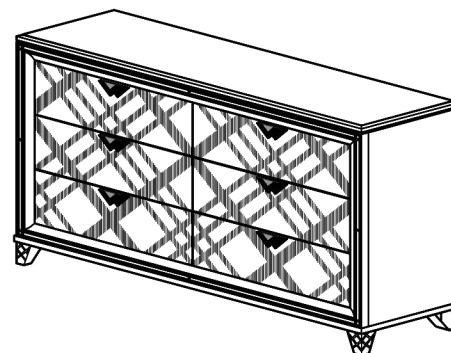

PARTS

#1 1pc

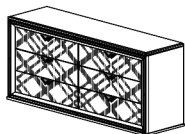

Dresser

#2 2pcs



Acrylic Leg

#3 2pcs



Metal Leg

#4 1pc

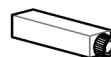

Center Leg

HARDWARE

#A 1pc



Allen Key

#B 4pcs



JCBC - M6 x 20mm

#C 4pcs



M6 Spring Washer

#D 4pcs



M6 Flat Washer

#E 1pc



Anti-tipping
Restraint Kit

ASSEMBLY INSTRUCTIONS

1

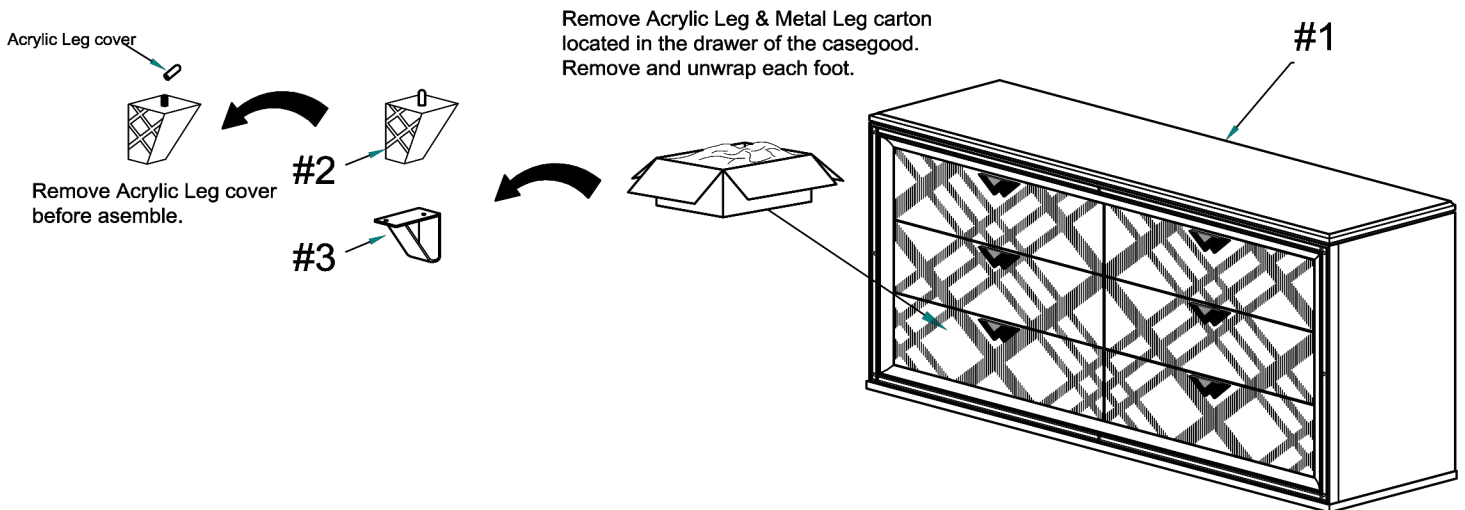

2

- Part #1 x 1pc
- Part #2 x 2pcs

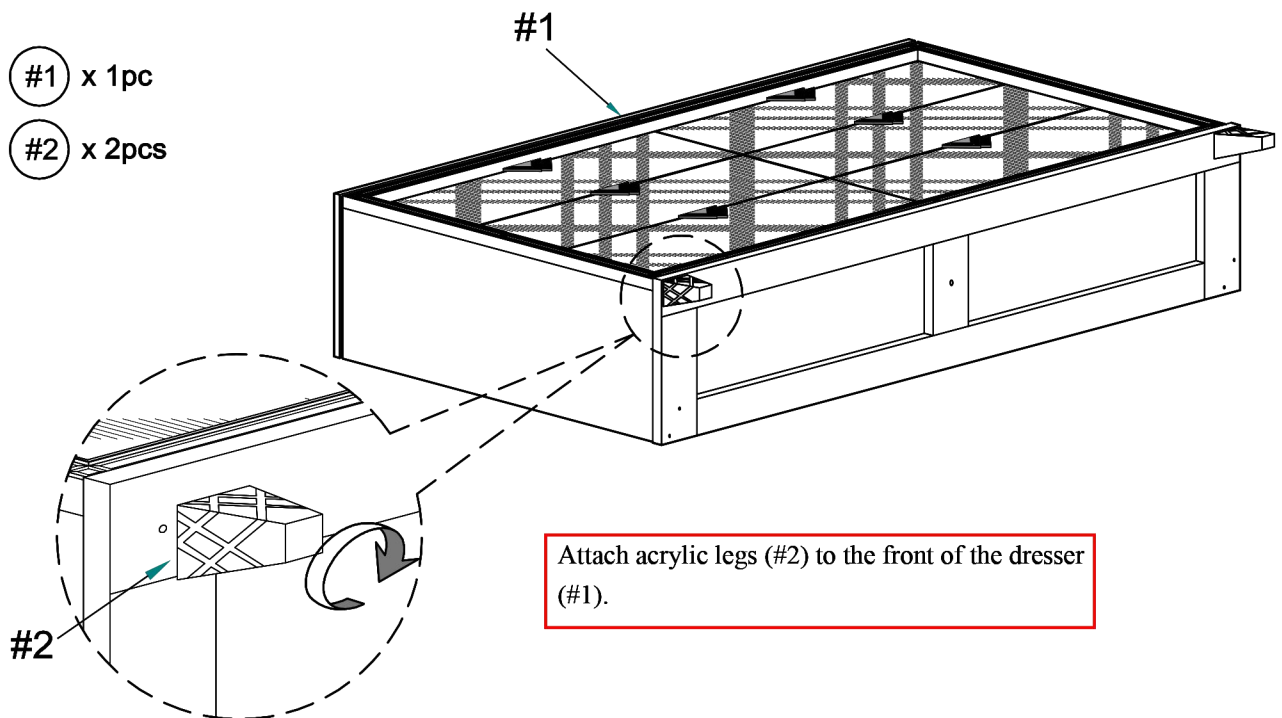

ASSEMBLY INSTRUCTIONS

3

Part (#1) x 1pc

Part (#3) x 2pcs

Hardware (#A) x 1pc

Hardware (#B) x 4pcs

Hardware (#C) x 4pcs

Hardware (#D) x 4pcs

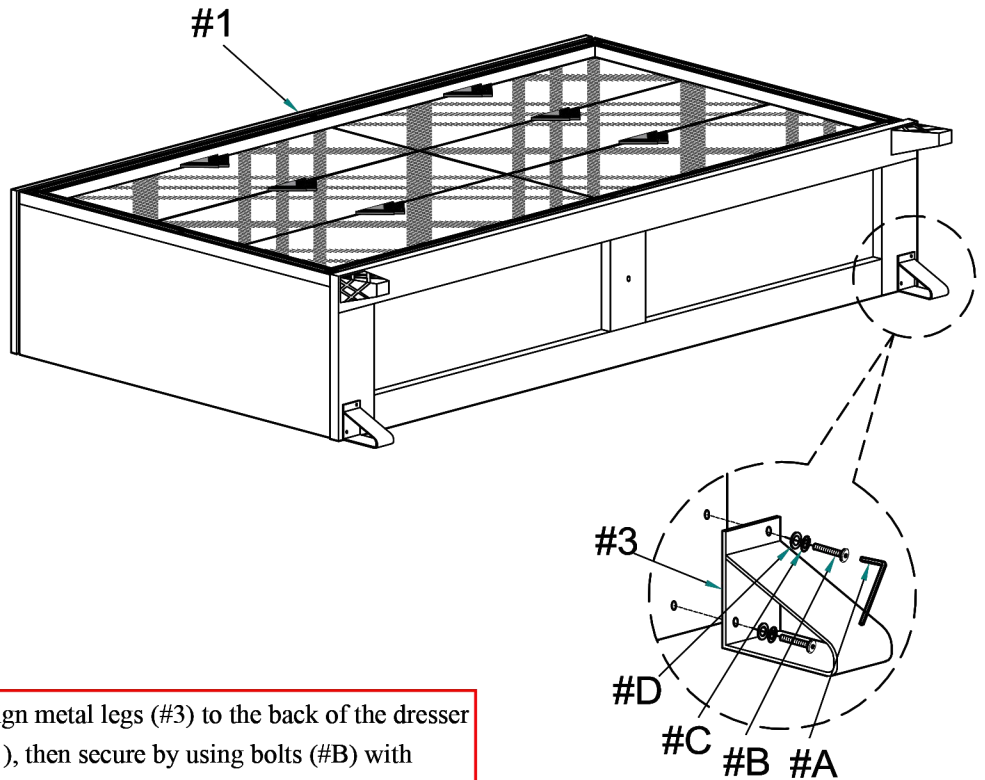

Align metal legs (#3) to the back of the dresser (#1), then secure by using bolts (#B) with washers (#C,D).

4

Part (#1) x 1pc

Part (#4) x 1pc

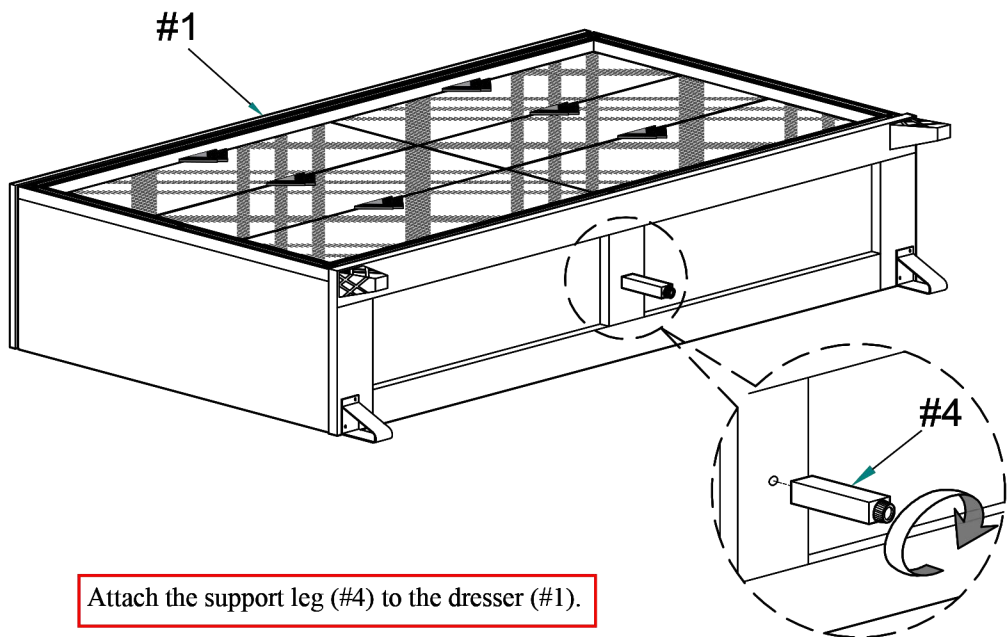

Attach the support leg (#4) to the dresser (#1).

ASSEMBLY INSTRUCTIONS

5

Part **#1** x 1pc

Hardware **#E** x 1pc

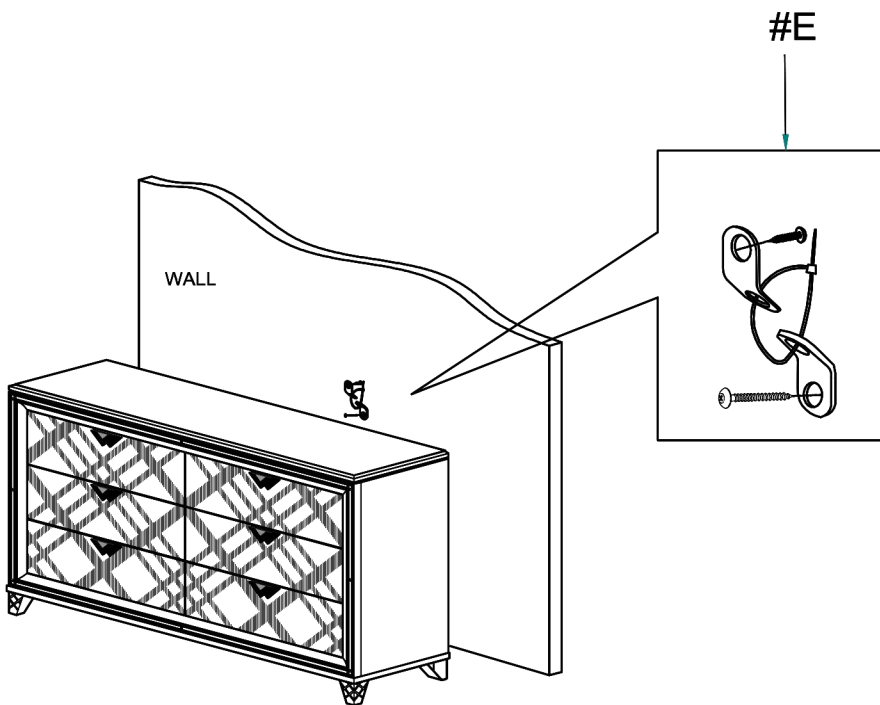

ASSEMBLY COMPLETED



Please ensure the furniture rests on an even and flat surface. If the product wobbles or feels loose, double-check all bolts and/or screws are properly tightened and secured.



Keep this handy!

Please retain this instruction manual and any order-related information for future reference.



Lift, don't drag!

To avoid damage to product please always LIFT the product when transporting or adjusting the placement.

ASSEMBLY INSTRUCTIONS

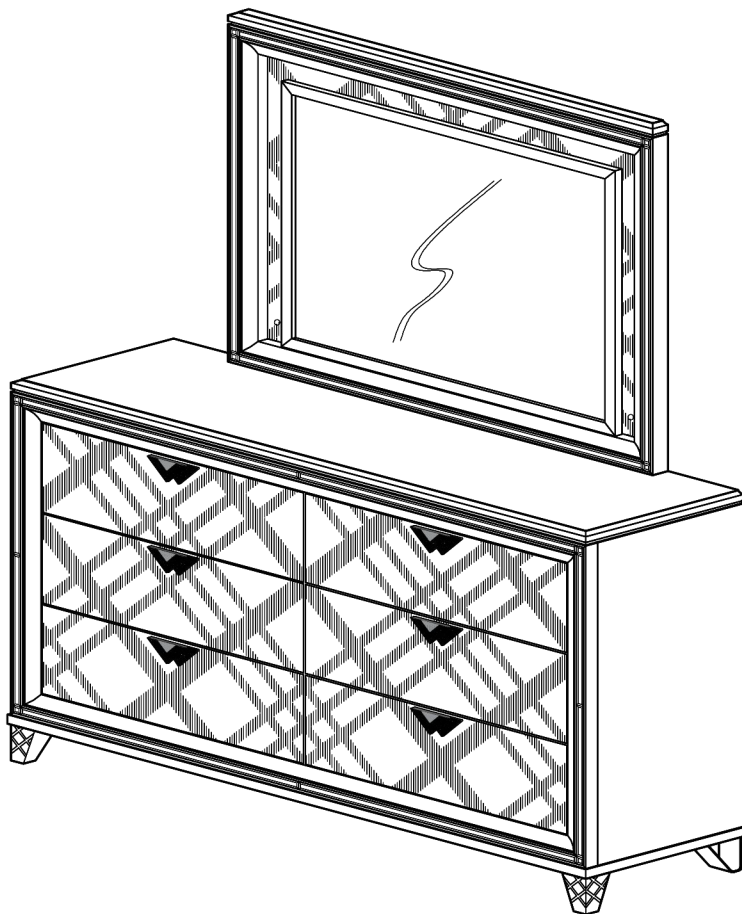

TOOLS REQUIRED



Allen Wrench

(Included)



Phillips
Screwdriver

(Not Included)



2 - People
Recommended

ASSEMBLY RATING



EASY —————> DIFFICULT

The Assembly Rating is a 5-point system showing the level of effort needed to assemble a specific product.



CHECK BEFORE STARTING

Are you missing anything?

Double-check all parts, hardware and accessories listed on Page 6 are accounted for.

Should we send any replacements?

Are there any irregularities or flaws in the parts? We can send replacements!

Check out our Quick Tips!

We recommend reviewing the pre-assembly handouts. Even experts need a refresher now and then!

Prep Time!

Please review the assembly instructions and all diagrams prior to assembling. Arrange parts as recommended on Page 7 and group identical hardware together to make assembling easier.

PRE ASSEMBLY INTRODUCTION

We understand building ready-to-assemble furniture can be a challenging experience for some. To help avoid confusion, we have provided some helpful tips that may speed up the process.

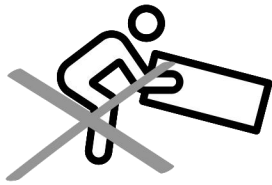

Teamwork

ALWAYS have at least two people to help with transporting and assembling the product to avoid potential injury and/or damage.

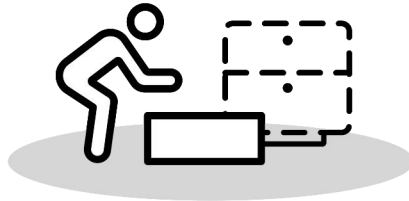
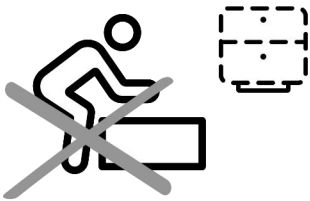

Suitable Location

Assembling near the area of the intended location is highly recommended.



Sufficient Space

Make sure you have enough space to move around during the assembly.

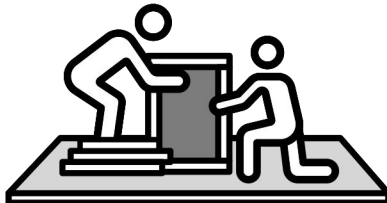

Avoid Scratches

Use cardboard, blankets or a carpeted area while assembling furniture to prevent scratches.

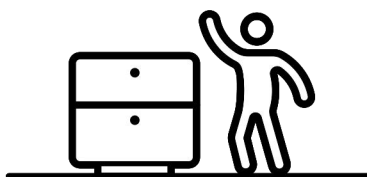
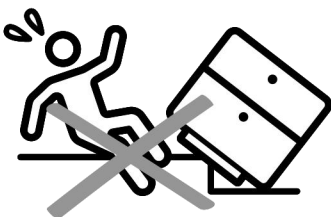

Flat Surface

Make sure the furniture rests on a flat and level surface with each leg evenly touching the floor.

ASSEMBLY AND CARE ADVICE



FAILURE TO FOLLOW THE GUIDELINES BELOW MAY RESULT IN INJURY AND/OR PROPERTY DAMAGE.



Position each part correctly and insert screws or bolts into their respective holes.

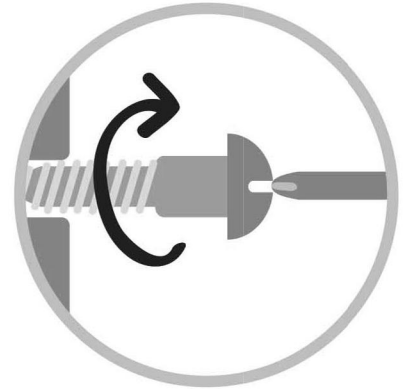

Turn clockwise to tighten and only tighten when step is completed or when instructed to do so.



Save the instructions and store any supplied tools for later maintenance.

Use the appropriate hand tools or power tools for assembly. Select steps, such as tightening screws and/or bolts, may require hand tools to avoid causing damage during assembly.



After two weeks, check and tighten any loose hardware and repeat again every six months thereafter.

IT IS THE USER'S RESPONSIBILITY TO MAINTAIN THE FURNITURE. THE HARDWARE MAY LOOSEN OVER TIME AND MAY CAUSE THE FURNITURE TO BE WOBBLY AND UNABLE TO SUPPORT ITS INTENDED WEIGHT CAPACITY. THIS MAY LEAD TO COLLAPSE AND MAY CAUSE SERIOUS INJURY.

MIRROR



- Please keep instructions for future reference.
- Check the quantity and irregularity of parts and hardware before you start.

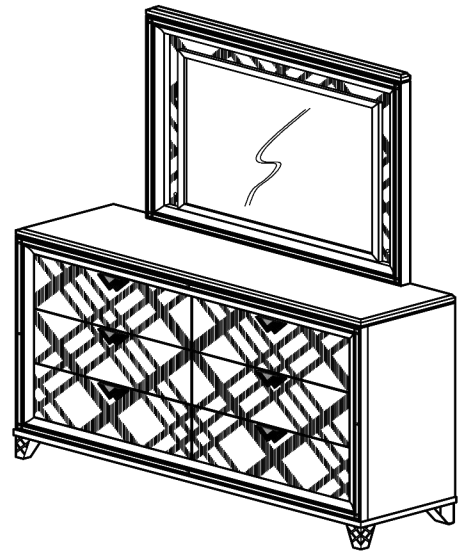

PARTS

#1 1pc

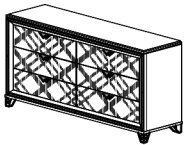

Dresser

#2 1pc

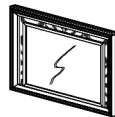

Mirror

#3 2pcs



Mirror Support

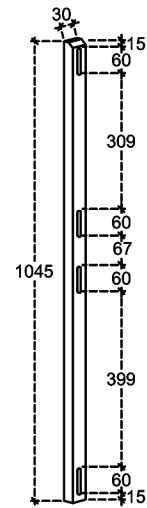

HARDWARE

#A 1pc



Allen Key

#B 8pcs



JCBC - M6 x 35mm

#C 8pcs



M6 Spring Washer

#D 8pcs



1/4" Flat Washer

#E 1pc



AC Adaptor

1

ASSEMBLY INSTRUCTIONS

Part #1 x 1pc

Part #2 x 1pc

Part #3 x 2pcs

Hardware #A x 1pc

Hardware #B x 8pcs

Hardware #C x 8pcs

Hardware #D x 8pcs

Hardware #E x 1pc

Ensure adapter socket connect to behind Mirror socket

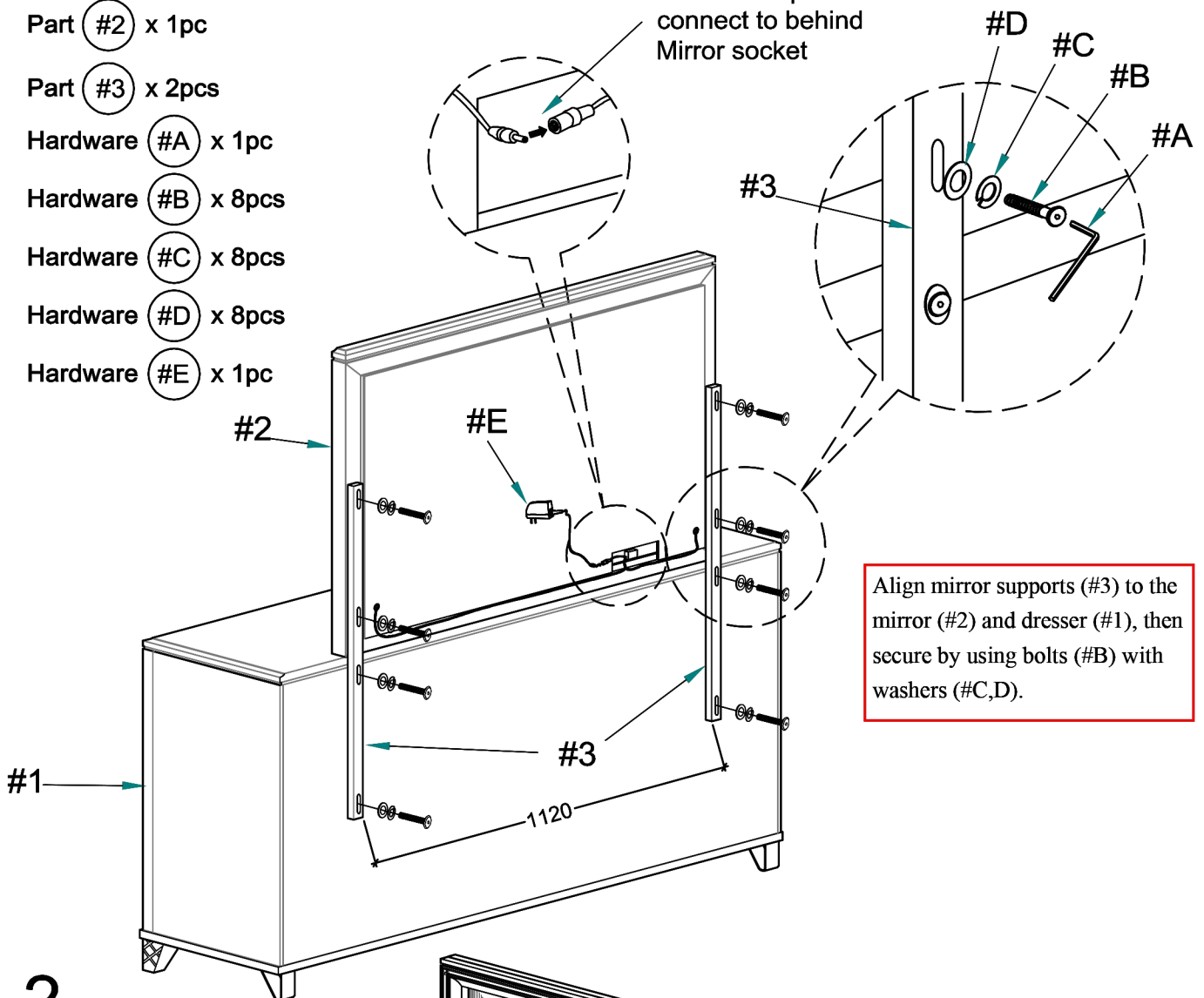

Align mirror supports (#3) to the mirror (#2) and dresser (#1), then secure by using bolts (#B) with washers (#C,D).

2

Lighting touch switch

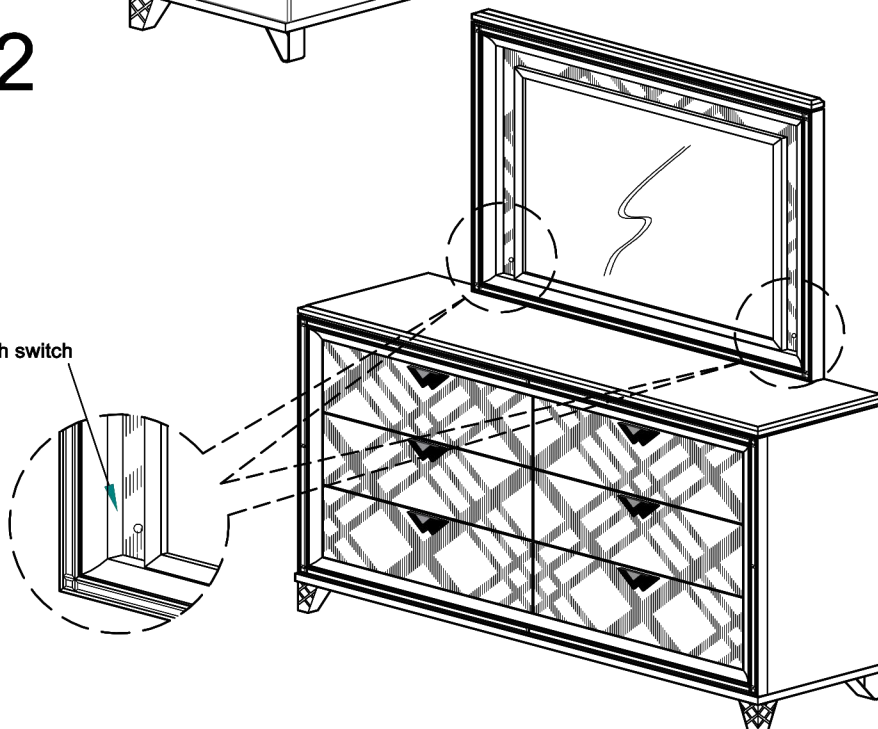

ASSEMBLY COMPLETED



Please ensure the furniture rests on an even and flat surface. If the product wobbles or feels loose, double-check all bolts and/or screws are properly tightened and secured.



Keep this handy!

Please retain this instruction manual and any order-related information for future reference.



Lift, don't drag!

To avoid damage to product please always LIFT the product when transporting or adjusting the placement.

ASSEMBLY INSTRUCTIONS

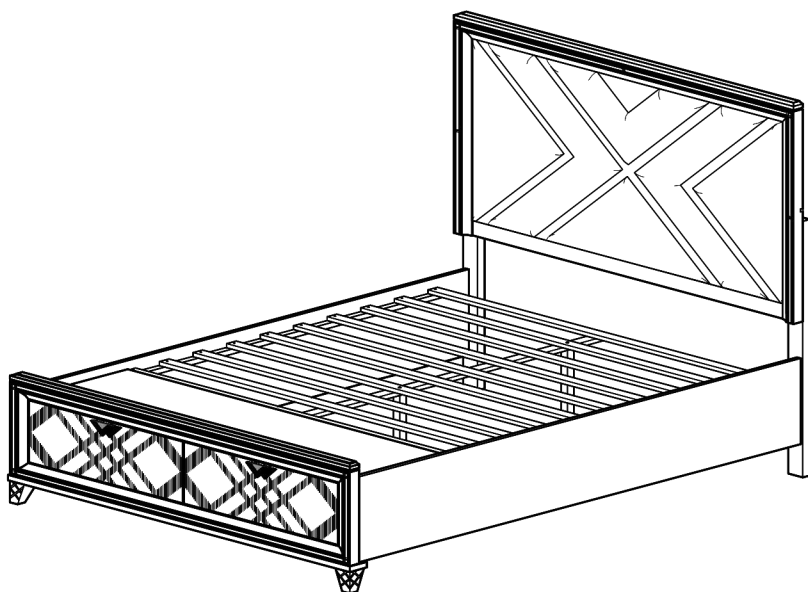

TOOLS REQUIRED

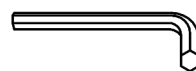

Allen Wrench

(Included)



Phillips
Screwdriver

(Not Included)



3 - People
Recommended

ASSEMBLY RATING



EASY —————> DIFFICULT

The Assembly Rating is a 5-point system showing the level of effort needed to assemble a specific product.



CHECK BEFORE STARTING

Are you missing anything?

Double-check all parts, hardware and accessories listed on Page 6 are accounted for.

Should we send any replacements?

Are there any irregularities or flaws in the parts? We can send replacements!

Check out our Quick Tips!

We recommend reviewing the pre-assembly handouts. Even experts need a refresher now and then!

Prep Time!

Please review the assembly instructions and all diagrams prior to assembling. Arrange parts as recommended on Page 7 and group identical hardware together to make assembling easier.

PRE ASSEMBLY INTRODUCTION

We understand building ready-to-assemble furniture can be a challenging experience for some. To help avoid confusion, we have provided some helpful tips that may speed up the process.

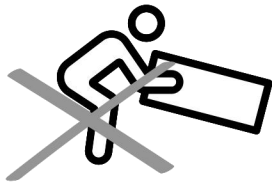

Teamwork

ALWAYS have at least two people to help with transporting and assembling the product to avoid potential injury and/or damage.

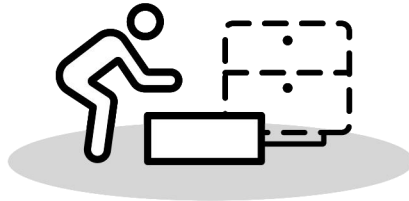
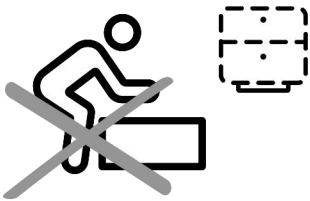

Suitable Location

Assembling near the area of the intended location is highly recommended.



Sufficient Space

Make sure you have enough space to move around during the assembly.

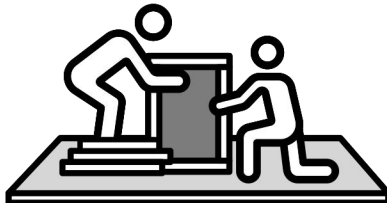

Avoid Scratches

Use cardboard, blankets or a carpeted area while assembling furniture to prevent scratches.

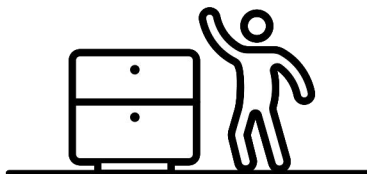
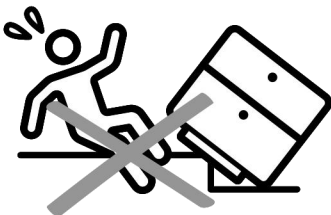

Flat Surface

Make sure the furniture rests on a flat and level surface with each leg evenly touching the floor.

ASSEMBLY AND CARE ADVICE



FAILURE TO FOLLOW THE GUIDELINES BELOW MAY RESULT IN INJURY AND/OR PROPERTY DAMAGE.



Position each part correctly and insert screws or bolts into their respective holes.

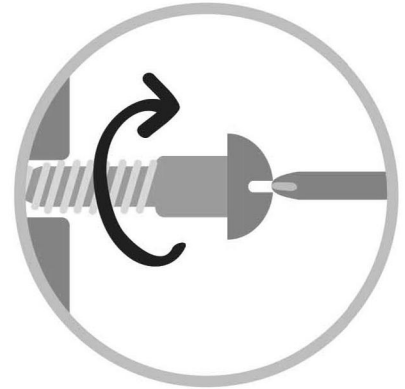

Turn clockwise to tighten and only tighten when step is completed or when instructed to do so.



Save the instructions and store any supplied tools for later maintenance.

Use the appropriate hand tools or power tools for assembly. Select steps, such as tightening screws and/or bolts, may require hand tools to avoid causing damage during assembly.



After two weeks, check and tighten any loose hardware and repeat again every six months thereafter.

IT IS THE USER'S RESPONSIBILITY TO MAINTAIN THE FURNITURE. THE HARDWARE MAY LOOSEN OVER TIME AND MAY CAUSE THE FURNITURE TO BE WOBBLY AND UNABLE TO SUPPORT ITS INTENDED WEIGHT CAPACITY. THIS MAY LEAD TO COLLAPSE AND MAY CAUSE SERIOUS INJURY.

QUEEN BED





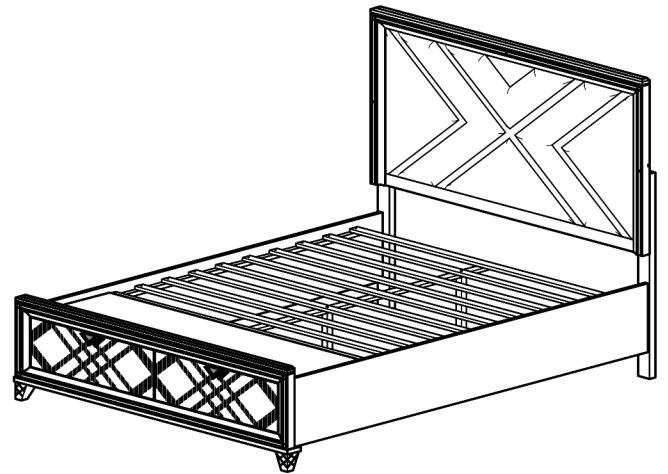

• Please keep instructions for future reference.
 • Check the quantity and irregularity of parts and hardware before you start.



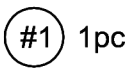
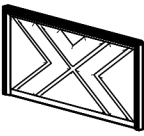

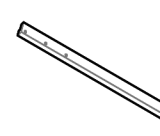

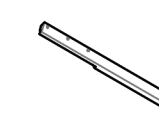



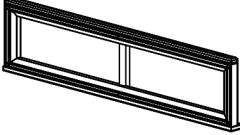



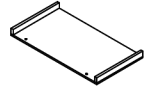

PARTS

PART LIST OF HEADBOARD

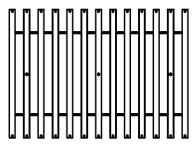
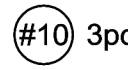
- | | | |
|---|---|---|
| 
#1 1pc

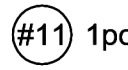
Headboard | 
#2 1pc

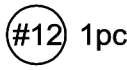
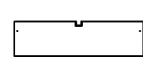
Headboard Leg - (R) | 
#3 1pc

Headboard Leg - (L) |
|---|---|---|

PART LIST OF FOOTBOARD

- | | | | | |
|---|---|---|---|--|
| 
#4 1pc

Footboard | 
#5 2pcs

Acrylic Leg | 
#6 1pc

Drawer Support Rail | 
#7 2pcs

Drawer | 
#8 2pcs

Drawer Base Panel |
| 
#9 13pcs

Roll Slat | 
#10 3pcs

Slat Support Leg
440mm x 30mm x 30mm | 
#11 1pc

Drawer Support Leg | 
#12 1pc

Slat Cover Panel | |

PART LIST OF SIDE RAIL

#13 2pcs



Side Rail

#14 1pc



Center Vertical Slat

HARDWARE

HARDWARE PACK IN HEADBOARD

#A 1pc



Allen Key

#B 6pcs



JCBC - M6 x 40mm

#C 6pcs



M6 Spring Washer

#D 6pcs



M6 Flat Washer

#E 1pc



AC Adapter

HARDWARE PACK IN FOOTBOARD

#F 1pc



Allen Key

#G 2pcs



JCBC - M6 x 16mm

#H 9pcs



JCBC - M6 x 35mm

#I 3pcs



JCBC - M6 x 60mm

#J 14pcs



M6 Spring Washer

#K 7pcs



M6 Flat Washer

#L 4pcs



1/4" Flat Washer

#M 26pcs



Screw 32mm

#N 2pcs











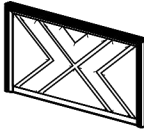
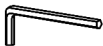

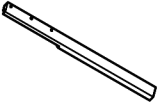

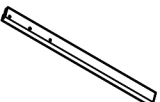

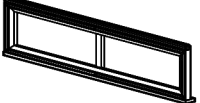
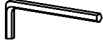





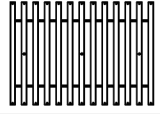

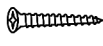

Screw 16mm

#O 4pcs

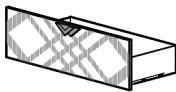
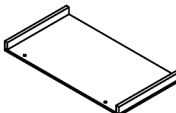

Adjustable Leveller

Carton	Designation		Part	Hardware
	Headboard (1pc)	#1		 #A x 1pc  #B x 6pcs
	Headboard Leg - (R) (1pc)	#2		 #C x 6pcs  #D x 6pcs
	Headboard Leg - (L) (1pc)	#3		 #E x 1pc
	Footboard (1pc)	#4		 #F x 1pc
	Acrylic Leg (2pcs)	#5		 #G x 2pcs  #H x 9pcs
	Drawer Support Rail (1pc)	#6		 #I x 3pcs
	Roll Slat (13pcs)	#9		 #J x 14pcs  #K x 7pcs
	Slat Support Leg (3pcs)	#10		 #L x 4pcs
	Drawer Support Leg (1pc)	#11		 #M x 26pcs  #N x 2pcs
	Slat Cover Panel (1pc)	#12		 #O x 4pcs
	Side Rail (2pcs)	#13		
	Center Vertical Slat (1pc)	#14		
	Drawer (2pcs)	#7		
	Drawer Base Panel (2pcs)	#8		

ASSEMBLY INSTRUCTIONS

1

Part #1 x 1pc

Part #2 x 1pc

Part #3 x 1pc

Hardware #A x 1pc

Hardware #B x 6pcs

Hardware #C x 6pcs

Hardware #D x 6pcs

Hardware #E x 1pc

Align HB legs (#2,3) to the headboard (#1), then secure by using bolts (#B) with washers (#C,D).

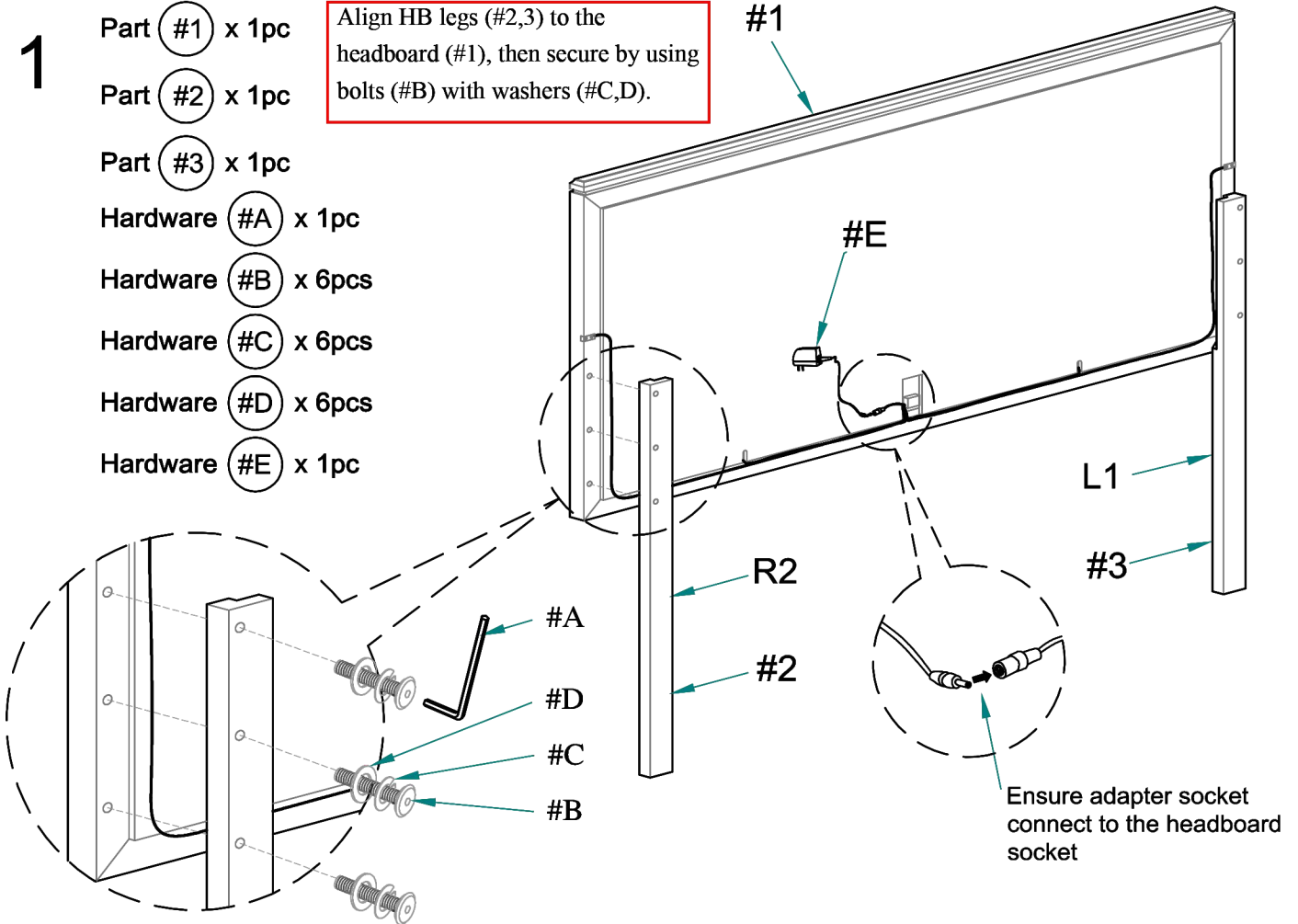

2

Part #1 x 1pc

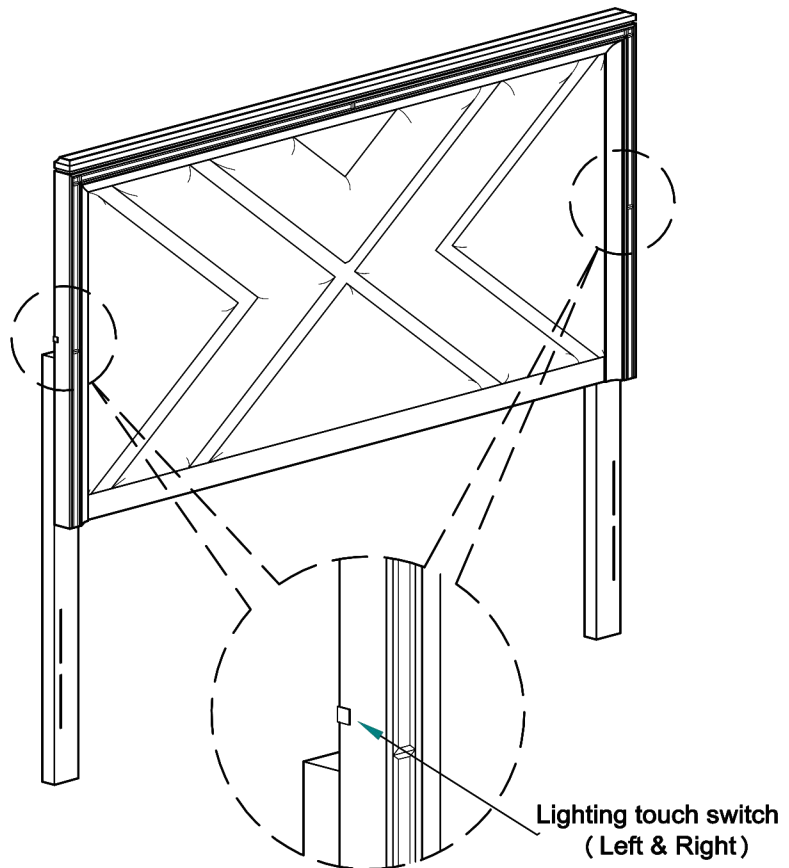

ASSEMBLY INSTRUCTIONS

3

Part #4 x 1pc

Part #5 x 2pcs

Acrylic Leg cover

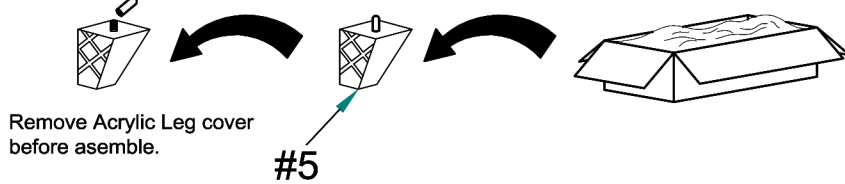

Remove Acrylic Leg cover before assemble.

Attach legs (#5) to footboard (#4).

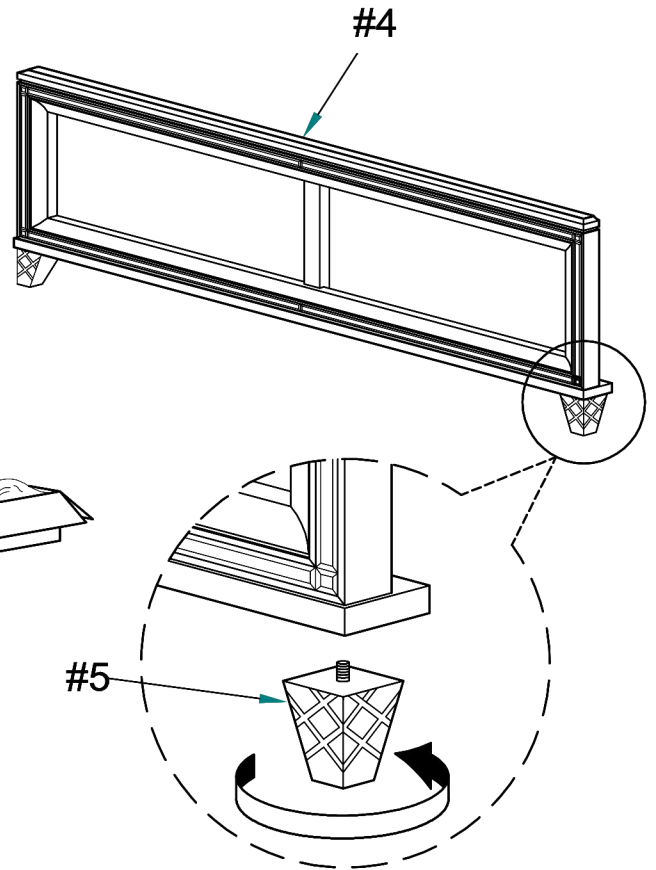

4

Part #1 x 1pc

Part #4 x 1pc

Part #13 x 2pcs

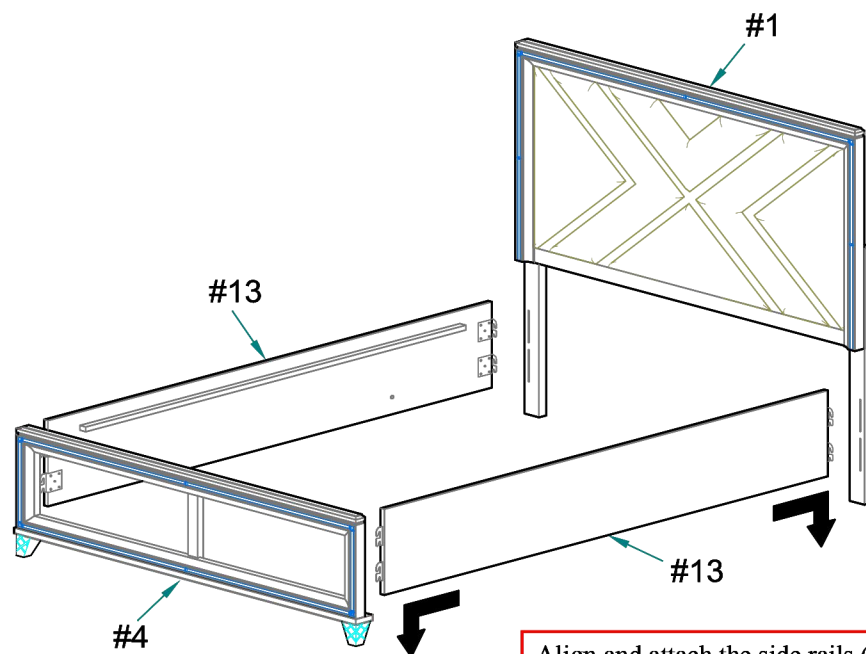

Align and attach the side rails (#13) to the headboard (#1) and footboard (#4).

ASSEMBLY INSTRUCTIONS

5

Part (#6) x 1pc

Hardware (#F) x 1pc

Hardware (#G) x 2pcs

Hardware (#J) x 2pcs

Hardware (#K) x 2pcs

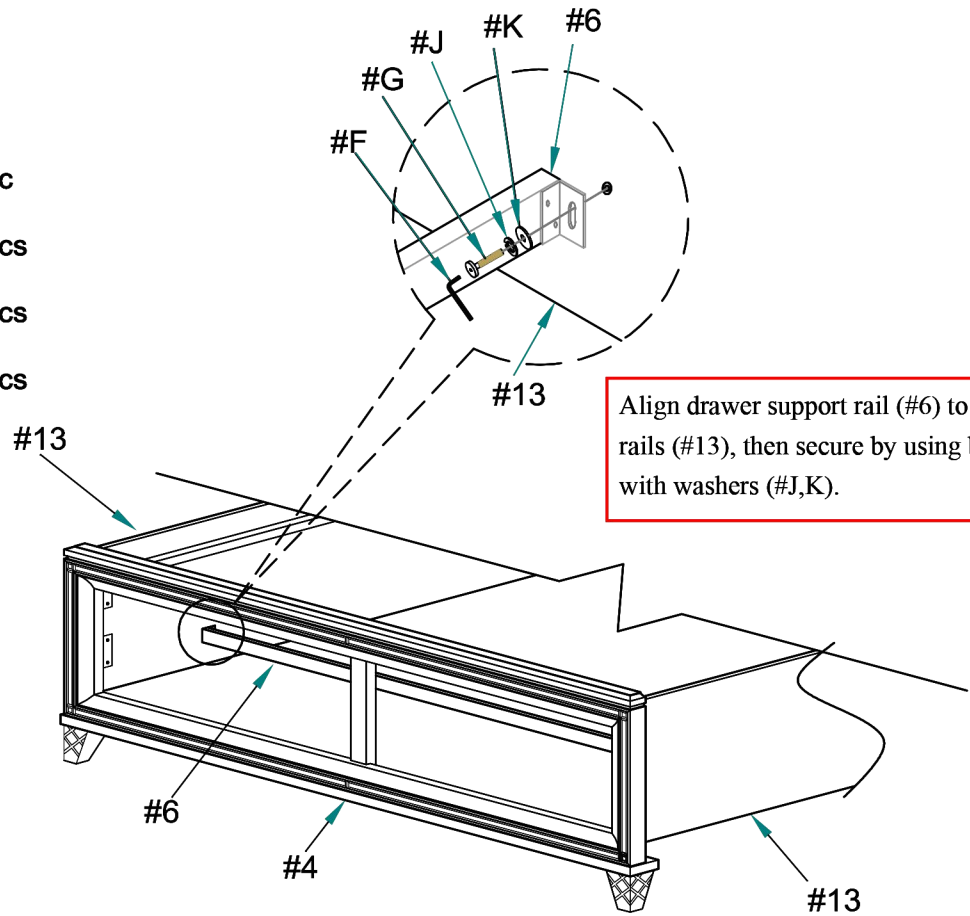

Align drawer support rail (#6) to the side rails (#13), then secure by using bolts (#G) with washers (#J,K).

6

Make sure to fully extend rails to see the black switch on the rails.

Step to remove the drawer :

1. Pull the drawer
2. Using both hands,
 - Left hands side - pull up switch
 - Right hands side - pull down switch
3. Then remove the drawer from the drawer base panel

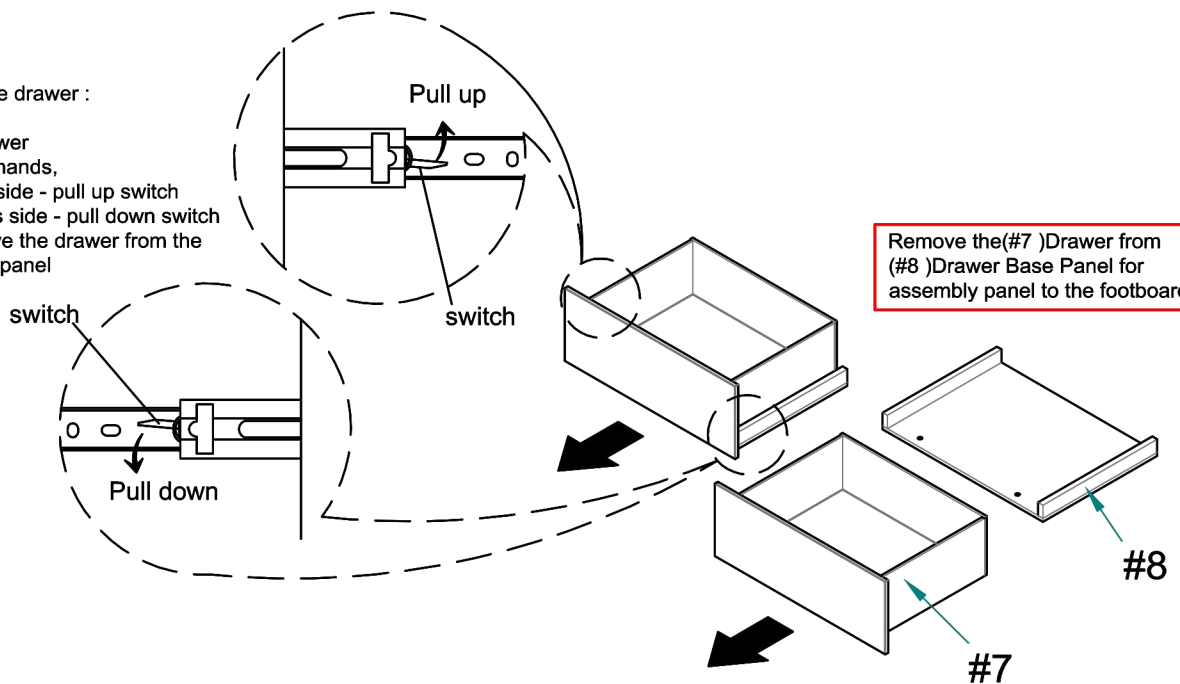

Remove the (#7) Drawer from (#8) Drawer Base Panel for assembly panel to the footboard.

ASSEMBLY INSTRUCTIONS

7

- Part (#8) x 2pcs
- Hardware (#F) x 1pc
- Hardware (#H) x 8pcs
- Hardware (#J) x 8pcs
- Hardware (#K) x 4pcs
- Hardware (#L) x 4pcs

Align drawer base panel (#8) to the footboard, then secure by using bolts (#H) with washers (#J,K,L) as shown in the diagrams.

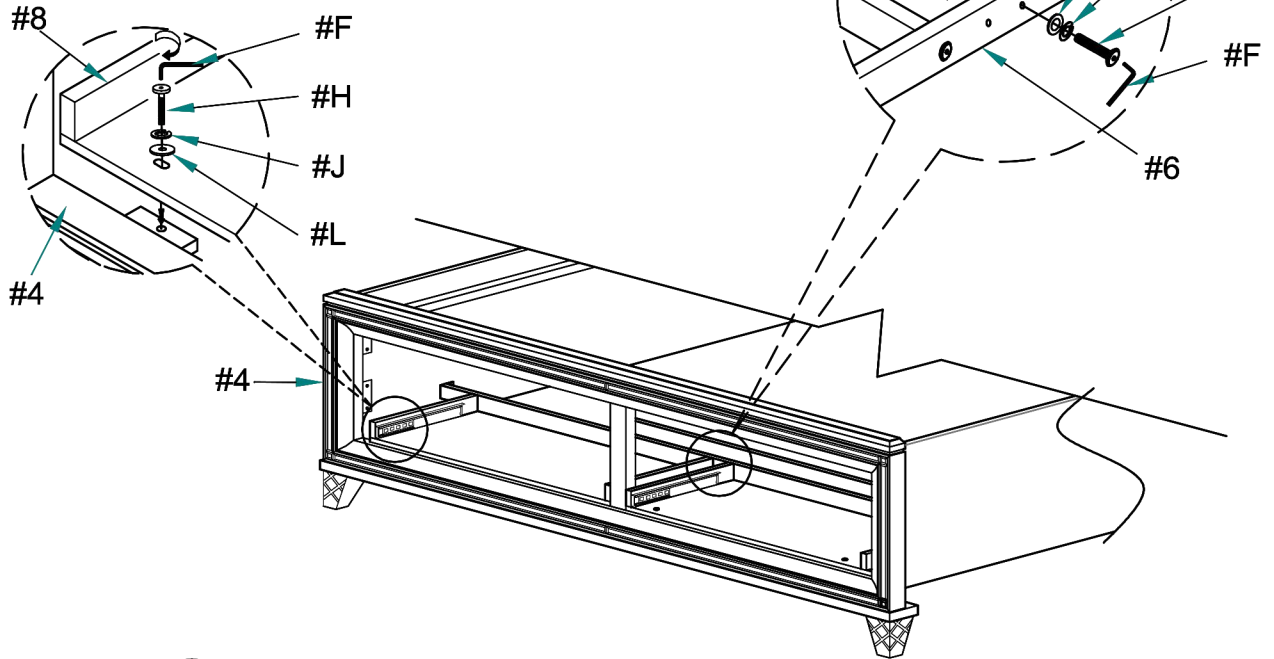

8

- Part (#11) x 1pc
- Hardware (#F) x 1pc
- Hardware (#H) x 1pc
- Hardware (#J) x 1pc
- Hardware (#K) x 1pc
- Hardware (#O) x 1pc

Align drawer support leg (#11), then secure by using bolts (#H) with washers (#J,K).

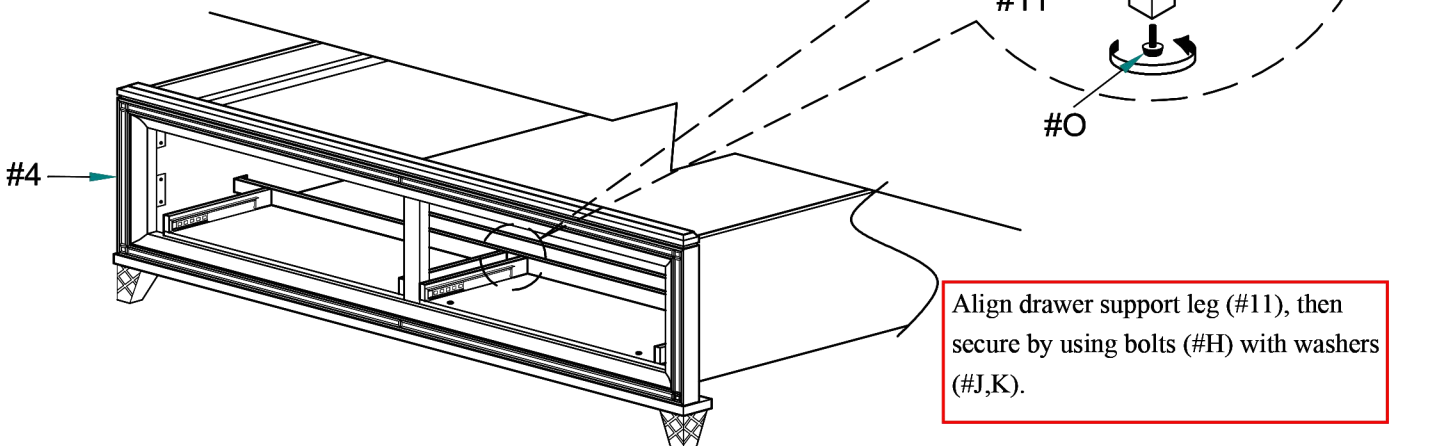

ASSEMBLY INSTRUCTIONS

9

Part (#7) x 2pcs

Step to install the drawer on the drawer base panel :

***Prefer 2 person to install the drawer

1. Adjust the ball bearing plate to the front as a diagram shows.
2. Then attach the drawer to the drawer base panel and install with carefully.

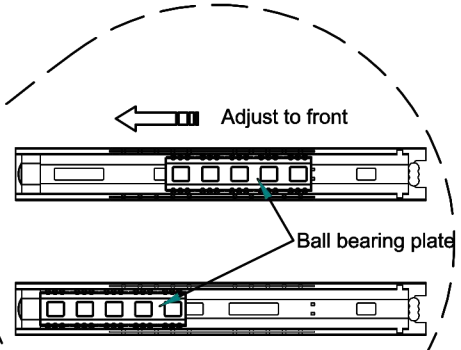

Insert the drawer (#7) to the footboard (#4)

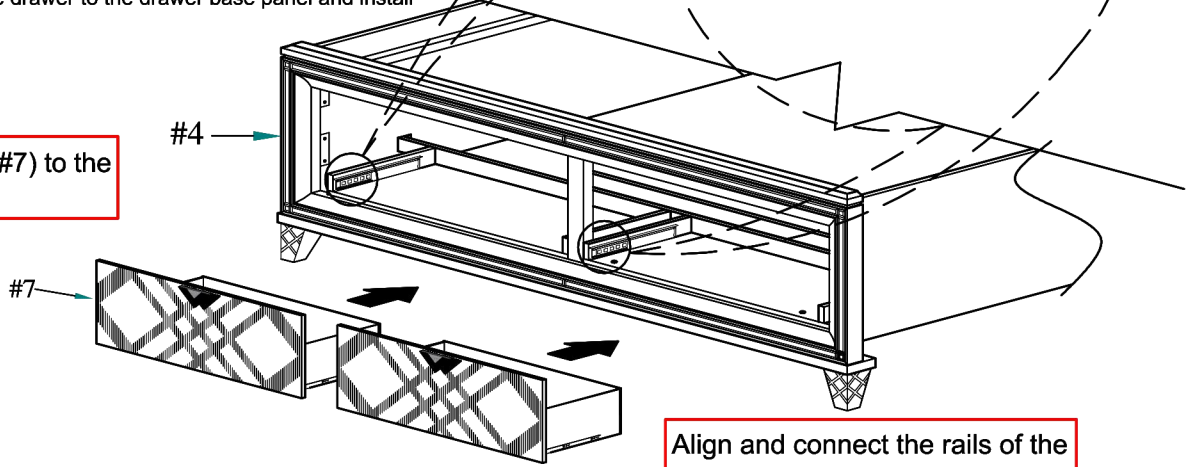

Align and connect the rails of the drawer base to the drawers.

10

Part (#9) x 13pcs Hardware (#F) x 1pc

Part (#10) x 3pcs Hardware (#I) x 3pcs

Part (#12) x 1pc Hardware (#J) x 3pcs

Part (#14) x 1pc Hardware (#M) x 26pcs

Hardware (#O) x 3pcs

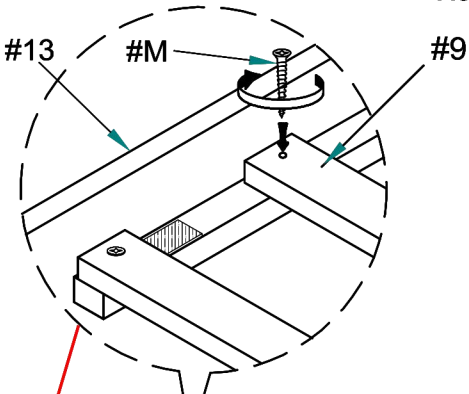

Align slats (#9) to the side rails (#13), then secure by using screws (#M).

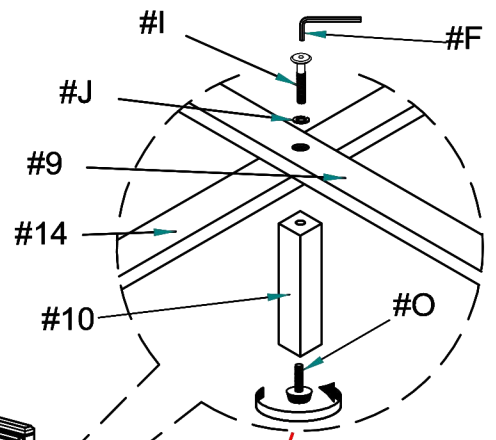

Align slat support (#14) to the slats (#9), then secure by using bolts (#I) with washers (#J) directly onto support leg (#10) as shown in the diagram.

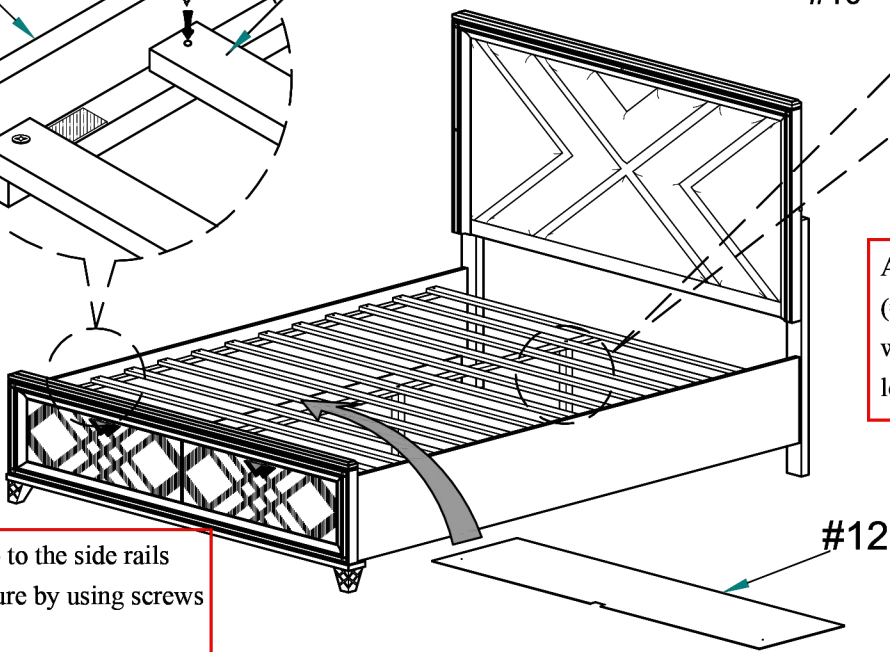

ASSEMBLY INSTRUCTIONS

11 Hardware (#N) x 2pcs

Align slat cover panel (#12) to the bottom slats, then secure by using screws (#N).

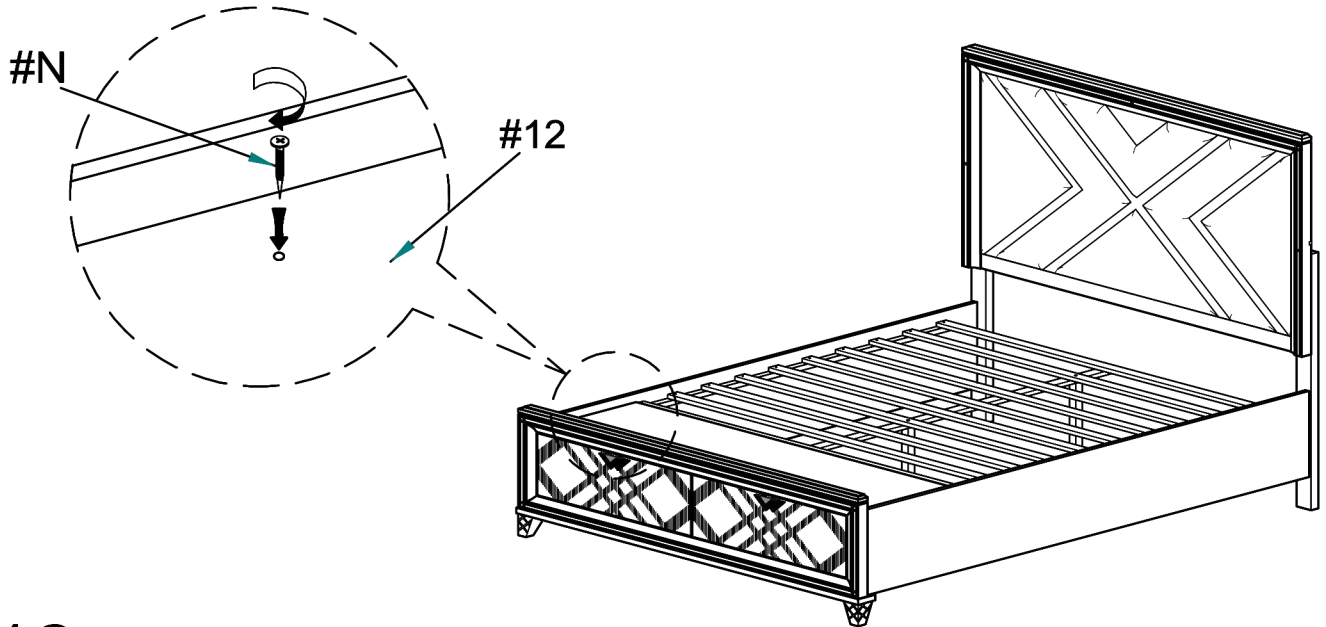

12

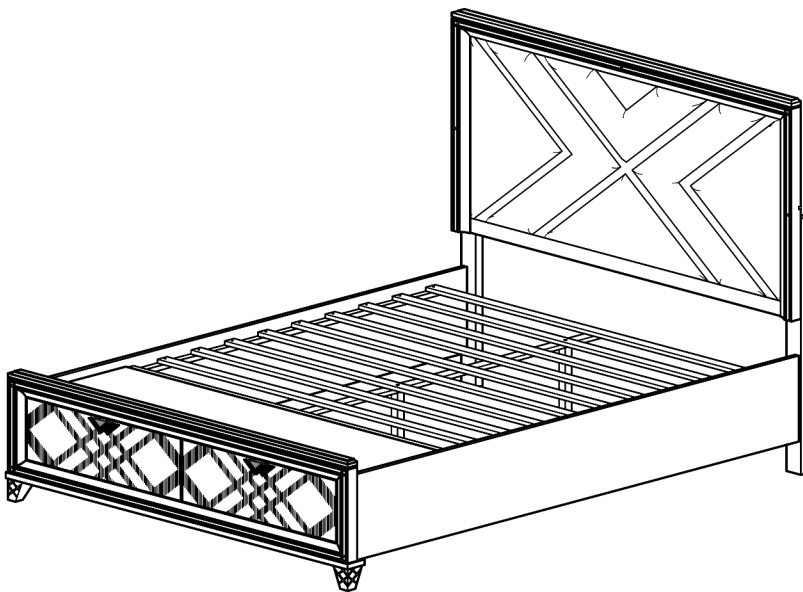

ASSEMBLY COMPLETED



Please ensure the furniture rests on an even and flat surface. If the product wobbles or feels loose, double-check all bolts and/or screws are properly tightened and secured.



Keep this handy!

Please retain this instruction manual and any order-related information for future reference.



Lift, don't drag!

To avoid damage to product please always LIFT the product when transporting or adjusting the placement.

ASSEMBLY INSTRUCTIONS

TOOLS REQUIRED

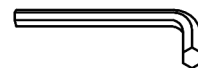

Allen Wrench
(Included)



Phillips Screwdriver
(Not Included)



3 - People
Recommended

ASSEMBLY RATING



EASY —————> DIFFICULT

The Assembly Rating is a 5-point system showing the level of effort needed to assemble a specific product.

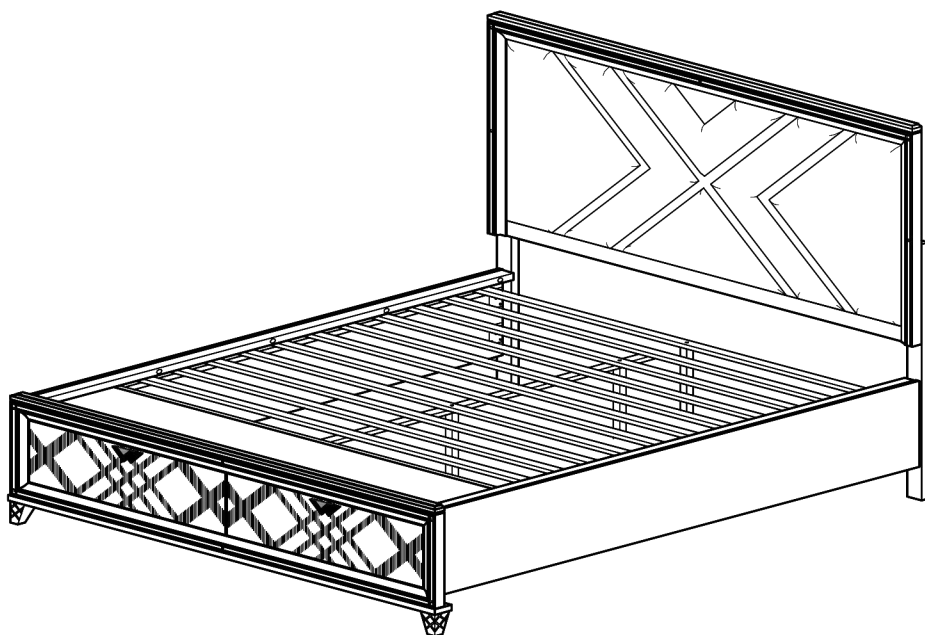



CHECK BEFORE STARTING

Are you missing anything?

Double-check all parts, hardware and accessories listed on Page 6 are accounted for.

Check out our Quick Tips!

We recommend reviewing the pre-assembly handouts. Even experts need a refresher now and then!

Should we send any replacements?

Are there any irregularities or flaws in the parts? We can send replacements!

Prep Time!

Please review the assembly instructions and all diagrams prior to assembling. Arrange parts as recommended on Page 7 and group identical hardware together to make assembling easier.

PRE ASSEMBLY INTRODUCTION

We understand building ready-to-assemble furniture can be a challenging experience for some. To help avoid confusion, we have provided some helpful tips that may speed up the process.

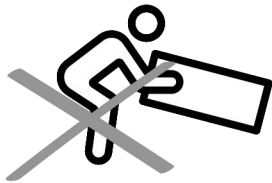

Teamwork

ALWAYS have at least two people to help with transporting and assembling the product to avoid potential injury and/or damage.

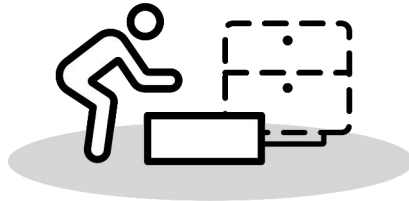
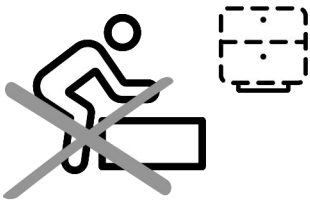

Suitable Location

Assembling near the area of the intended location is highly recommended.



Sufficient Space

Make sure you have enough space to move around during the assembly.

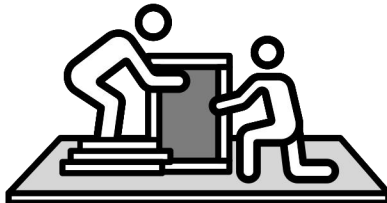

Avoid Scratches

Use cardboard, blankets or a carpeted area while assembling furniture to prevent scratches.

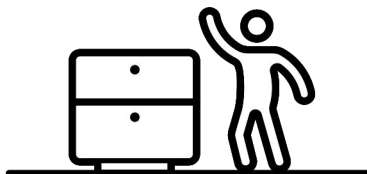
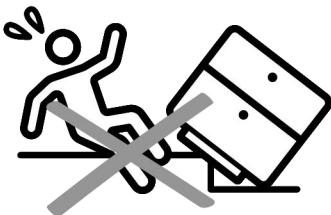

Flat Surface

Make sure the furniture rests on a flat and level surface with each leg evenly touching the floor.

ASSEMBLY AND CARE ADVICE



FAILURE TO FOLLOW THE GUIDELINES BELOW MAY RESULT IN INJURY AND/OR PROPERTY DAMAGE.



Position each part correctly and insert screws or bolts into their respective holes.



Use the appropriate hand tools or power tools for assembly. Select steps, such as tightening screws and/or bolts, may require hand tools to avoid causing damage during assembly.

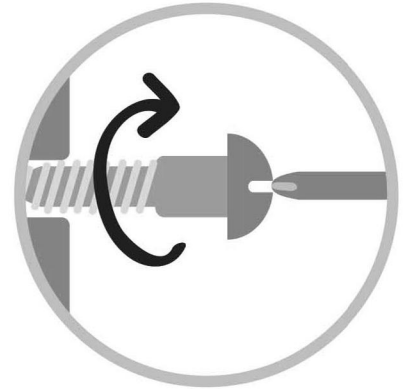

Turn clockwise to tighten and only tighten when step is completed or when instructed to do so.



Save the instructions and store any supplied tools for later maintenance.



After two weeks, check and tighten any loose hardware and repeat again every six months thereafter.

IT IS THE USER'S RESPONSIBILITY TO MAINTAIN THE FURNITURE. THE HARDWARE MAY LOOSEN OVER TIME AND MAY CAUSE THE FURNITURE TO BE WOBBLY AND UNABLE TO SUPPORT ITS INTENDED WEIGHT CAPACITY. THIS MAY LEAD TO COLLAPSE AND MAY CAUSE SERIOUS INJURY.

CAL KING BED



- Please keep instructions for future reference.
- Check the quantity and irregularity of parts and hardware before you start.

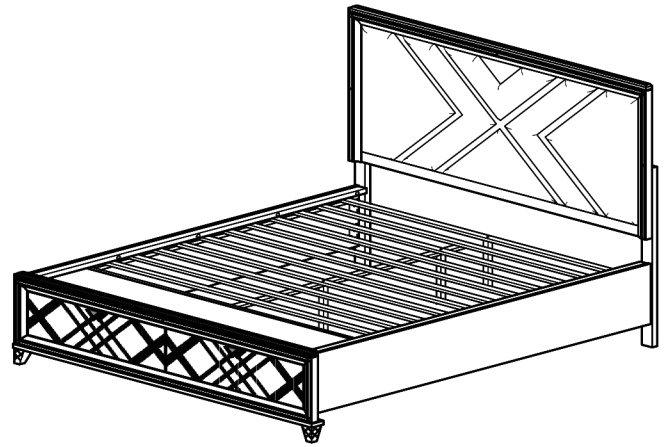

PARTS

PART LIST OF HEADBOARD

#1 1pc

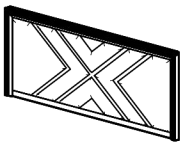

Headboard

#2 1pc

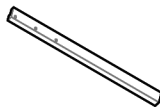

Headboard Leg - (R)

#3 1pc



Headboard Leg - (L)

PART LIST OF FOOTBOARD

#4 1pc

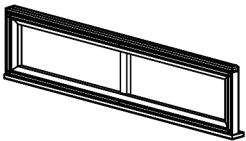

Footboard

#5 2pcs



Acrylic Leg

#6 1pc



Drawer Support Rail

#7 2pcs

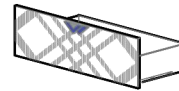

Drawer

#8 2pcs

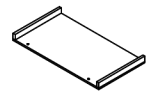

Drawer Base Panel

#9 13pcs

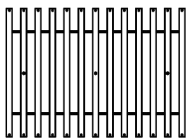

Roll Slat

#10 3pcs



Slat Support Leg
440mm x 30mm x 30mm

#11 1pc





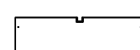

Drawer Support Leg

#12 1pc



Slat Cover Panel

PART LIST OF SIDE RAIL











#13 2pcs	#14 1pc	#15 2pcs	#16 1pc	#17 1pc
				
Side Rail	Center Vertical Slat	Top Cap	Slat	Slat Support (long) 455mm x 30mm x 30mm

HARDWARE



HARDWARE PACK IN HEADBOARD











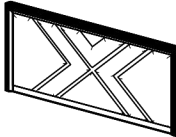

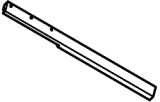

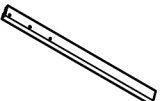

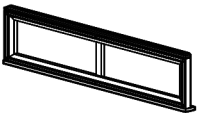





#A 1pc	#B 6pcs	#C 6pcs	#D 6pcs	#E 1pc
				
Allen Key	JCBC - M6 x 40mm	M6 Spring Washer	M6 Flat Washer	AC Adapter

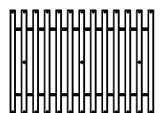

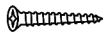





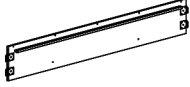
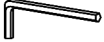

HARDWARE PACK IN FOOTBOARD

#F 1pc	#G 2pcs	#H 9pcs	#I 3pcs	#J 14pcs
				
Allen Key	JCBC - M6 x 16mm	JCBC - M6 x 35mm	JCBC - M6 x 60mm	M6 Spring Washer
#K 7pcs	#L 4pcs	#M 26pcs	#N 2pcs	#O 4pcs
				
M6 Flat Washer	1/4" Flat Washer	Screw 32mm	Screw 16mm	Adjustable Leveller

HARDWARE PACK IN SIDE RAIL

#P 1pc	#Q 1pc	#R 10pcs	#S 11pcs	#T 10pcs
				
Allen Key	JCBC - M6 x 35mm	JCBC - M6 x 45mm	M6 Spring Washer	M6 Spring Washer
#U 2pcs	#V 1pc			
				
Screw 32mm	Adjustable Leveller			

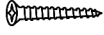
Carton	Designation		Part	Hardware
	Headboard (1pc)	#1		 #A x 1pc  #B x 6pcs
	Headboard Leg - (R) (1pc)	#2		 #C x 6pcs  #D x 6pcs
	Headboard Leg - (L) (1pc)	#3		 #E x 1pc
	Footboard (1pc)	#4		 #F x 1pc  #G x 2pcs
	Acrylic Leg (2pcs)	#5		 #H x 9pcs  #I x 3pcs
	Drawer Support Rail (1pc)	#6		 #J x 14pcs  #K x 7pcs
	Roll Slat (13pcs)	#9		 #L x 4pcs  #M x 26pcs
	Slat Support Leg (3pcs)	#10		 #N x 2pcs  #O x 4pcs
	Drawer Support Leg (1pc)	#11		
	Slat Cover Panel (1pc)	#12		

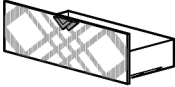
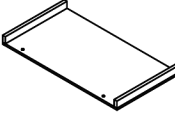
Carton	Designation	Part		Hardware
	Side Rail (2pcs)	#13		 #P x 1pc
	Center Vertical Slat (1pc)	#14		 #Q x 1pc  #R x 10pcs
	Top Cap (2pcs)	#15		 #S x 11pcs  #T x 10pcs
	Slat (1pc)	#16		 #U x 2pcs
	Slat Support Leg (1pc)	#17		 #Y x 1pcs
	Drawer (2pcs)	#7		
	Drawer Base Panel (2pcs)	#8		

ASSEMBLY INSTRUCTIONS

1

Part #1 x 1pc

Part #2 x 1pc

Part #3 x 1pc

Hardware #A x 1pc

Hardware #B x 6pcs

Hardware #C x 6pcs

Hardware #D x 6pcs

Hardware #E x 1pc

Align HB legs (#2,3) to the headboard (#1), then secure by using bolts (#B) with washers (#C,D).

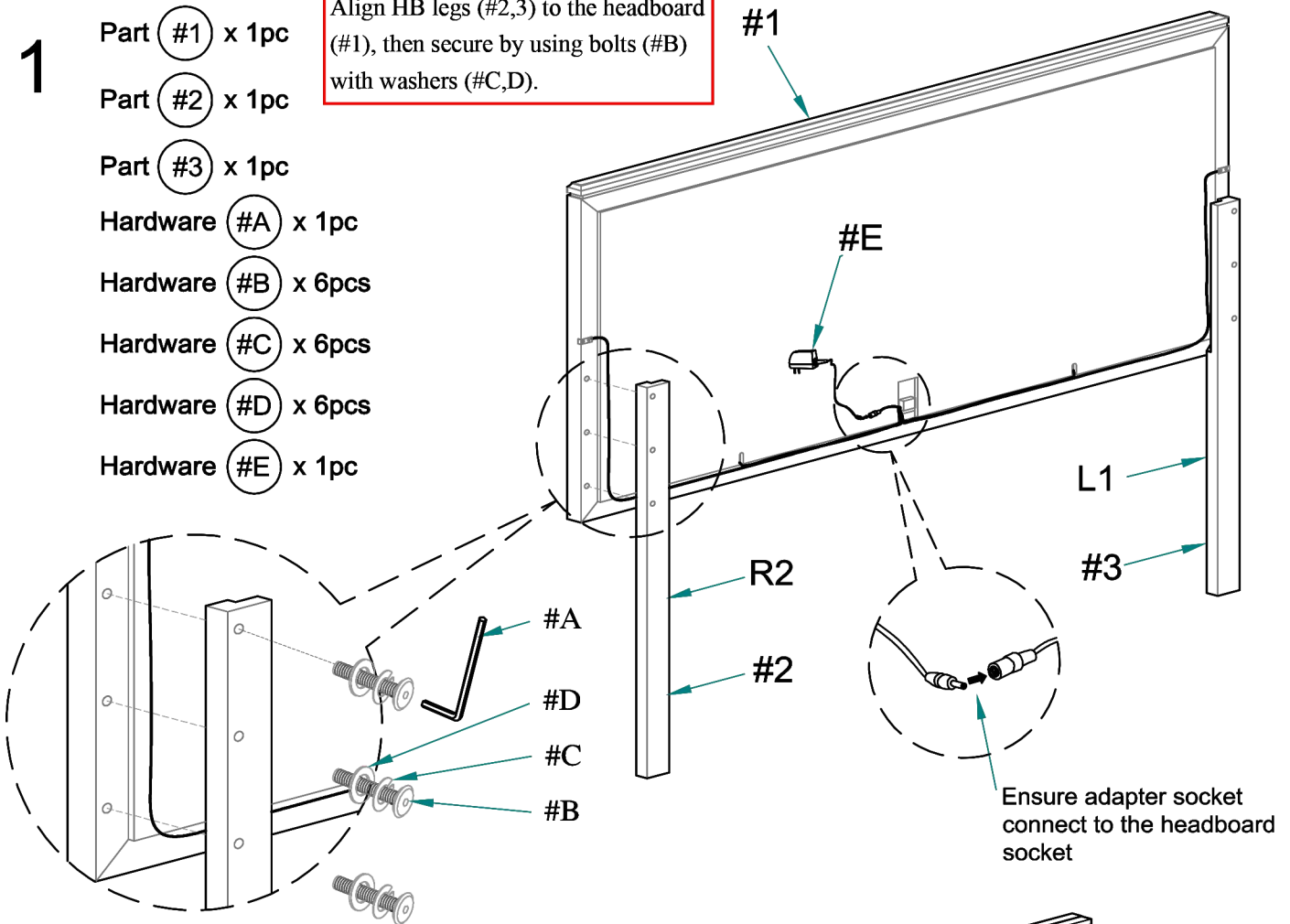

2

Part #1 x 1pc

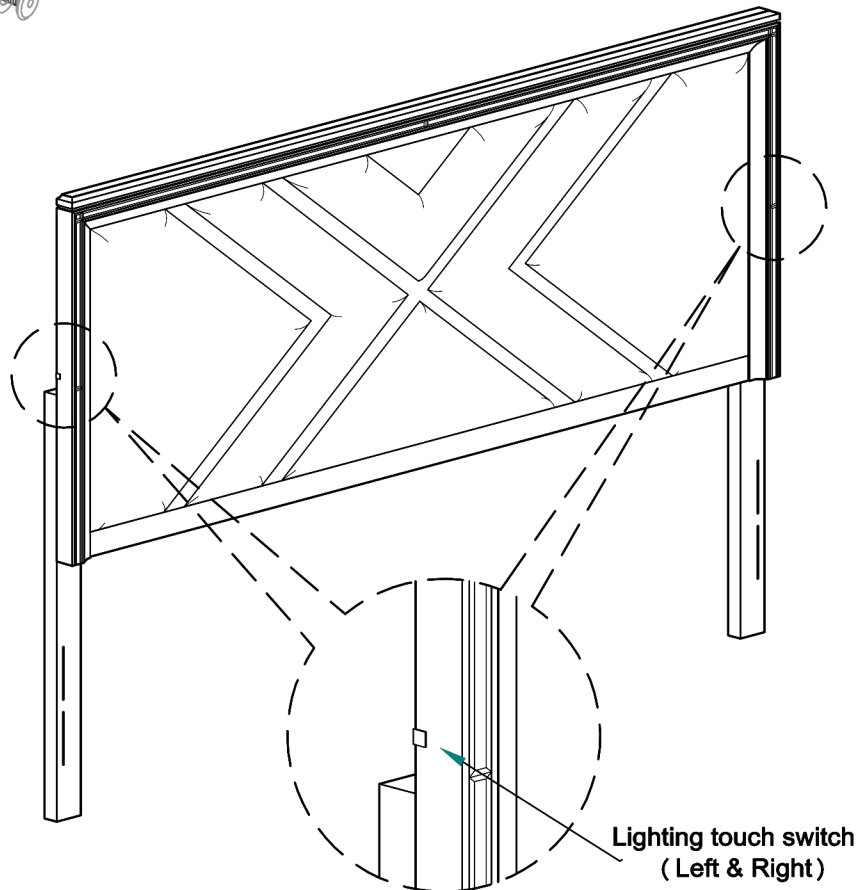

ASSEMBLY INSTRUCTIONS

3

Part #4 x 1pc

Part #5 x 2pcs

Attach legs (#5) to footboard (#4).

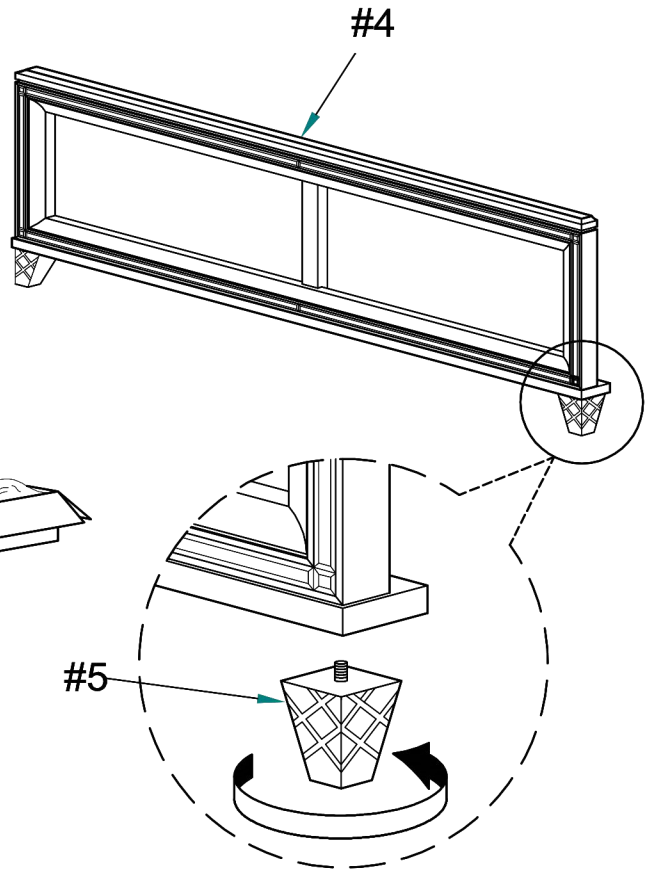

Acrylic Leg cover

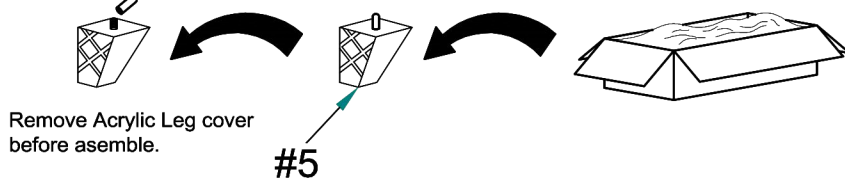

4

Part #1 x 1pc

Part #4 x 1pc

Part #13 x 2pcs

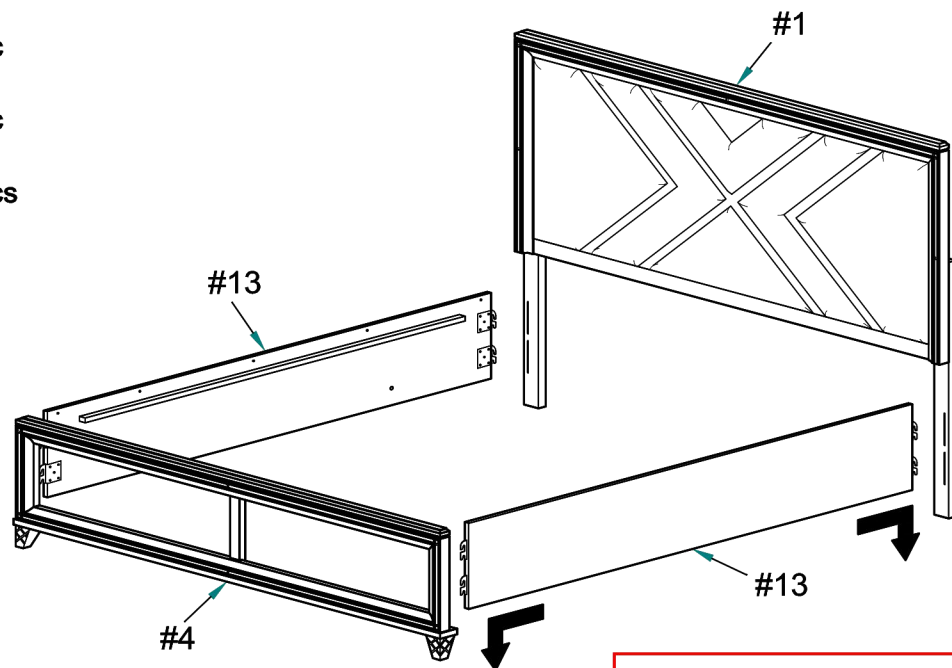

Align and attach the side rails (#13) to the headboard (#1) and footboard (#4).

ASSEMBLY INSTRUCTIONS

5

Part (#6) x 1pc

Hardware (#F) x 1pc

Hardware (#G) x 2pcs

Hardware (#J) x 2pcs

Hardware (#K) x 2pcs

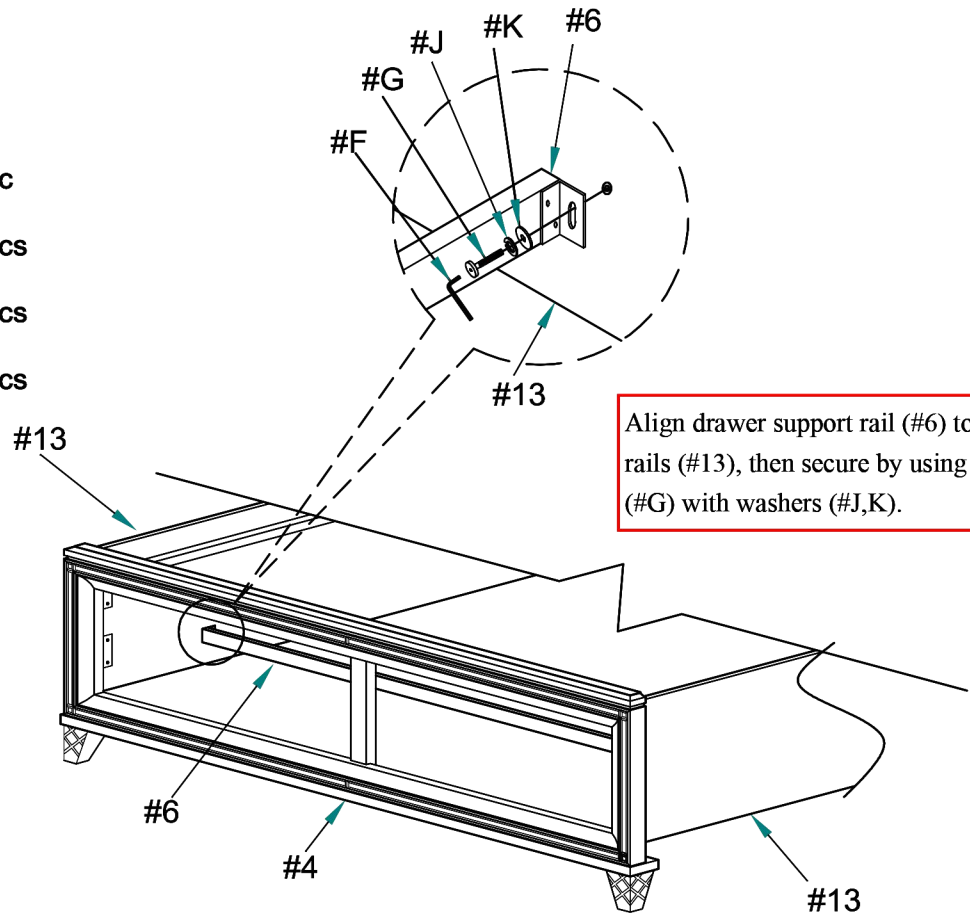

6

Make sure to fully extend rails to see the black switch on the rails.

Step to remove the drawer :

1. Pull the drawer
2. Using both hands,
 - Left hands side - pull up switch
 - Right hands side - pull down switch
3. Then remove the drawer from the drawer base panel

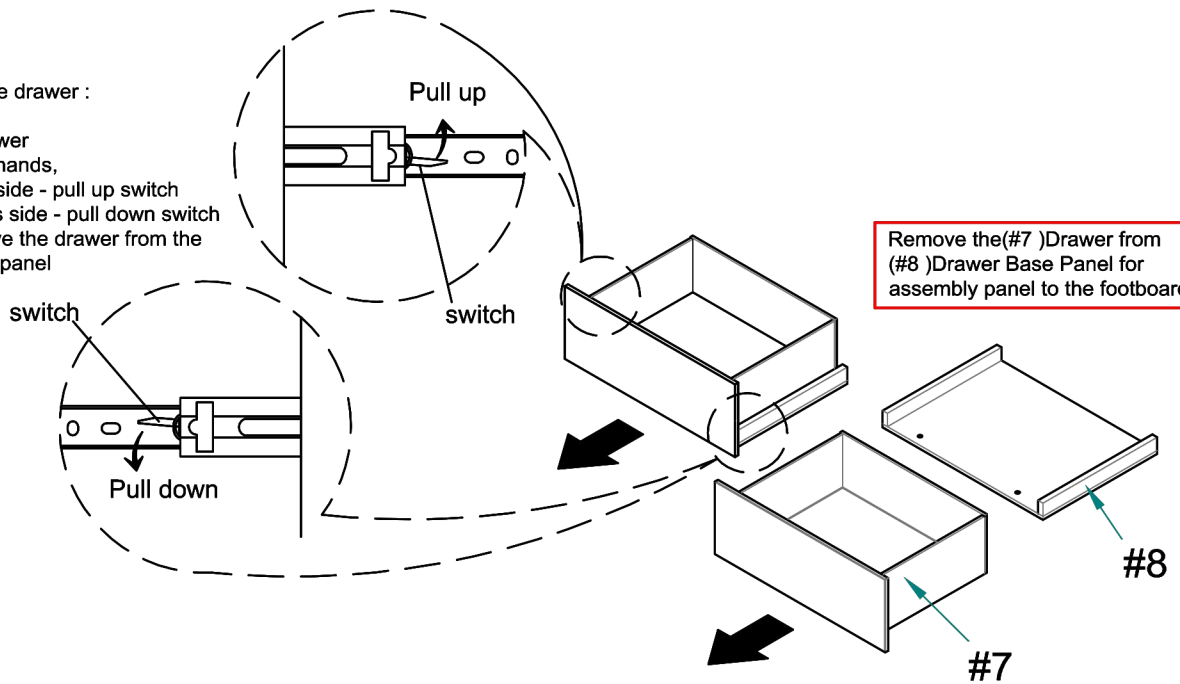

ASSEMBLY INSTRUCTIONS

7

- Part (#8) x 2pcs
- Hardware (#F) x 1pc
- Hardware (#H) x 8pcs
- Hardware (#J) x 8pcs
- Hardware (#K) x 4pcs
- Hardware (#L) x 4pcs

Align drawer base panel (#8) to the footboard, then secure by using bolts (#H) with washers (#J,K,L) as shown in the diagrams.

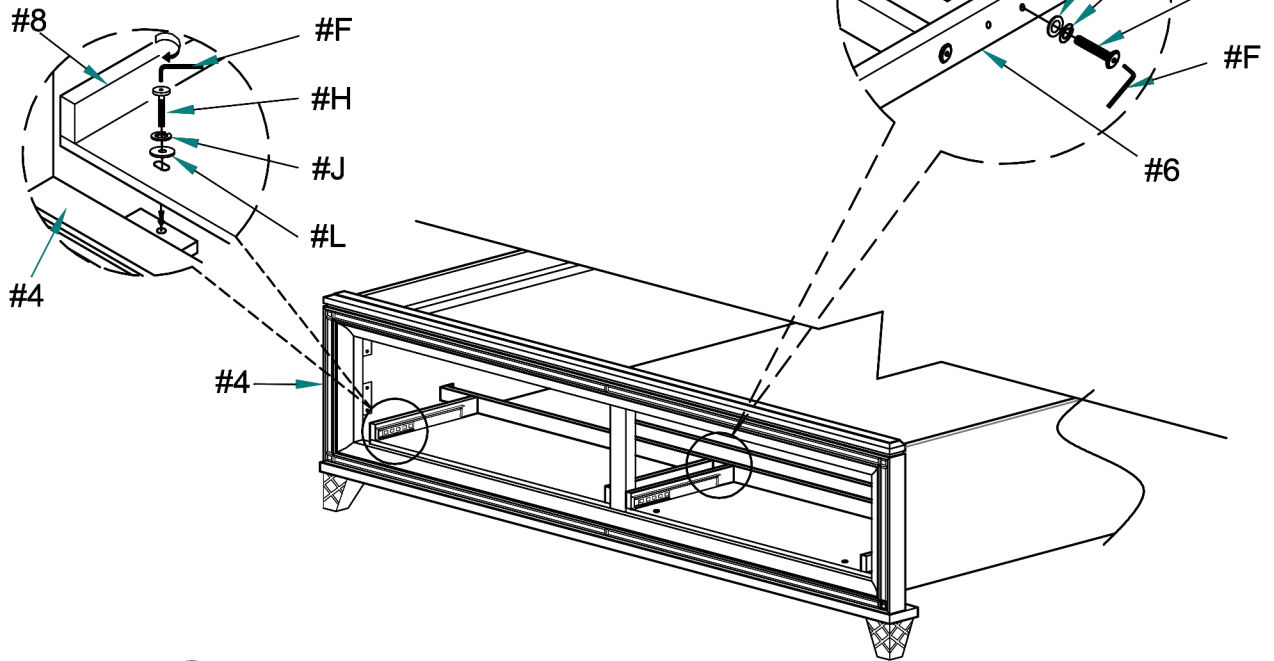

8

- Part (#11) x 1pc
- Hardware (#F) x 1pc
- Hardware (#H) x 1pc
- Hardware (#J) x 1pc
- Hardware (#K) x 1pc
- Hardware (#O) x 1pc

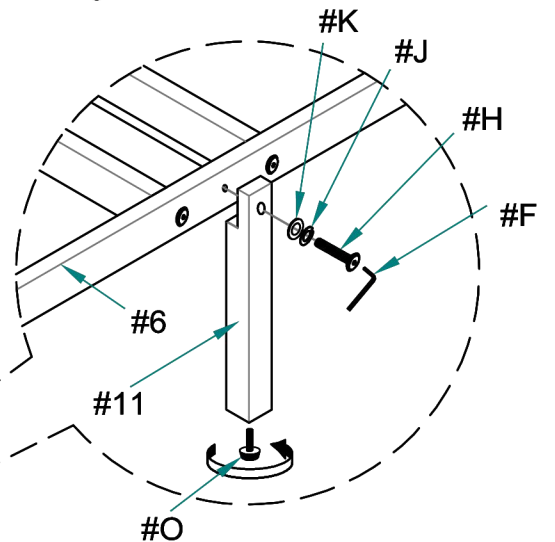

Align drawer support leg (#11), then secure by using bolts (#H) with washers (#J,K).

ASSEMBLY INSTRUCTIONS

9

Part #7 x 2pcs

Step to install the drawer on the drawer base panel :

***Prefer 2 person to install the drawer

1. Adjust the ball bearing plate to the front as a diagram shows.
2. Then attach the drawer to the drawer base panel and install with carefully.

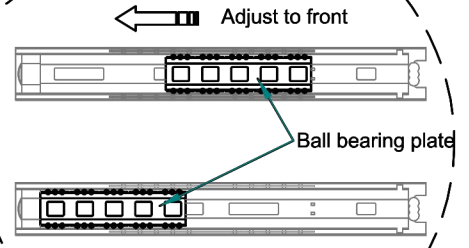

Insert the drawer (#7) to the footboard (#4)

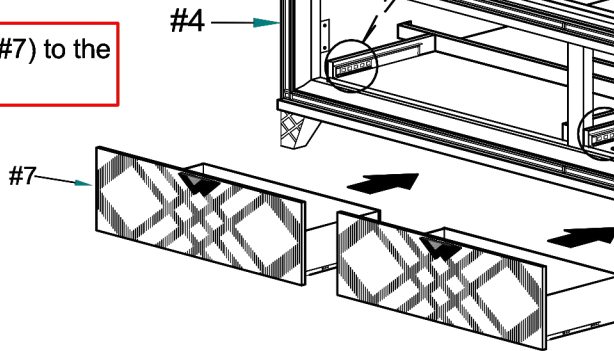

Align and connect the rails of the drawer base to the drawers.

10

Part #9 x 13pcs Hardware #F x 1pc

Part #10 x 3pcs Hardware #I x 3pcs

Part #14 x 1pc Hardware #J x 3pcs

Hardware #M x 26pcs

Hardware #O x 3pcs

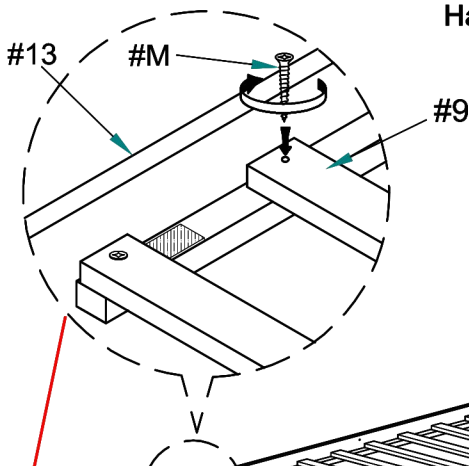

Align slats (#9) to the side rails (#13), then secure by using screws (#M).

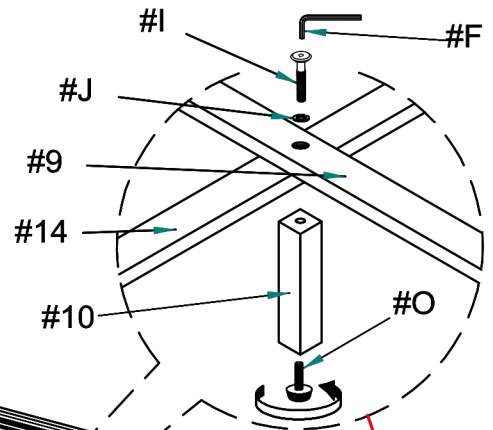

Align slat support (#14) to the slats (#9), then secure by using bolts (#I) with washers (#J) directly onto support leg (#10) as shown in the diagram.

ASSEMBLY INSTRUCTIONS

11

Part (#12) x 1pc Hardware (#P) x 1pc

Part (#16) x 1pc Hardware (#Q) x 1pc

Part (#17) x 1pc Hardware (#S) x 1pc

Hardware (#U) x 2pcs

Hardware (#V) x 1pc

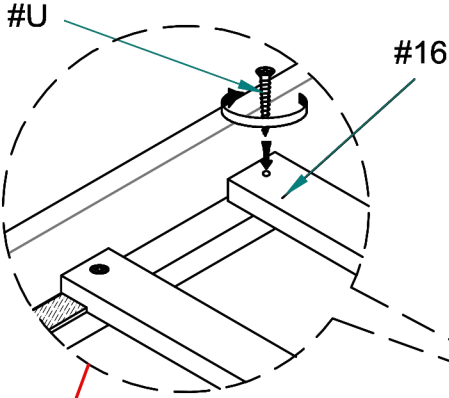

Align slat (#16) to the side rails, then secure by using screws (#U).

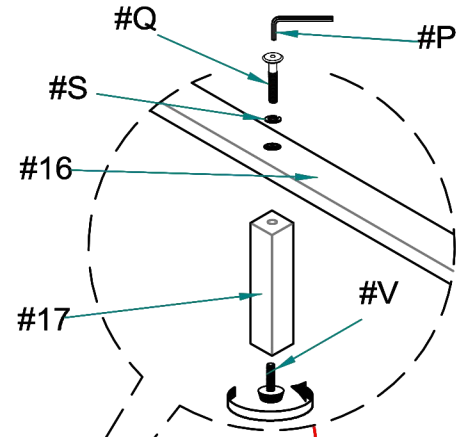

Align slat support (#17) to the slat (#16), then secure by using bolts (#Q) with washers (#S).

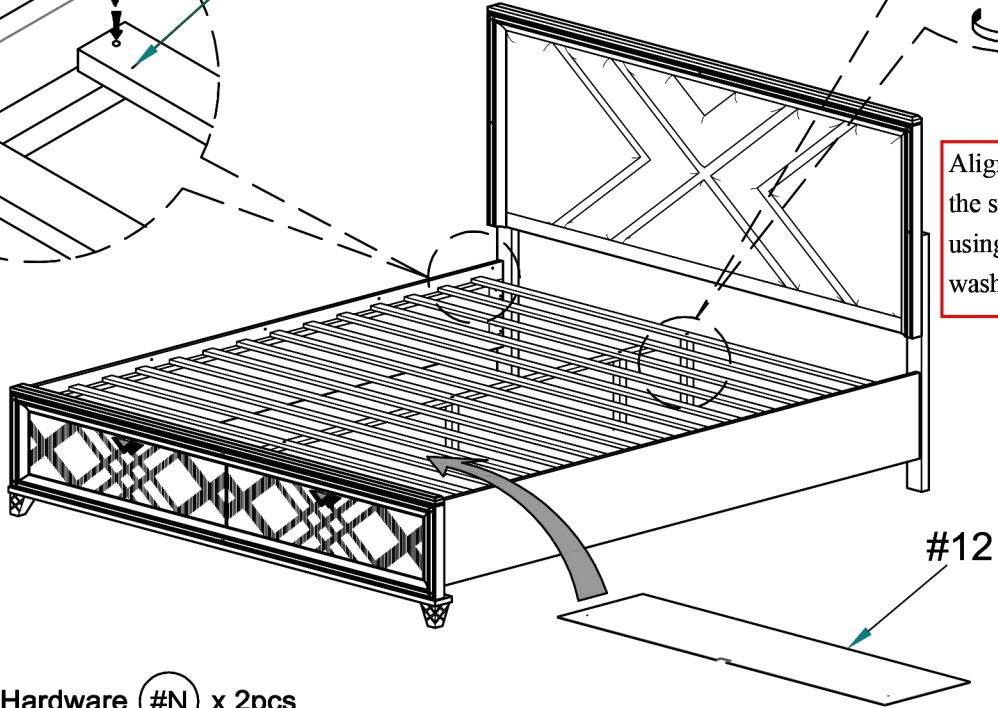

12

Hardware (#N) x 2pcs

Secure slat cover (#12) to slats by using screws (#N).

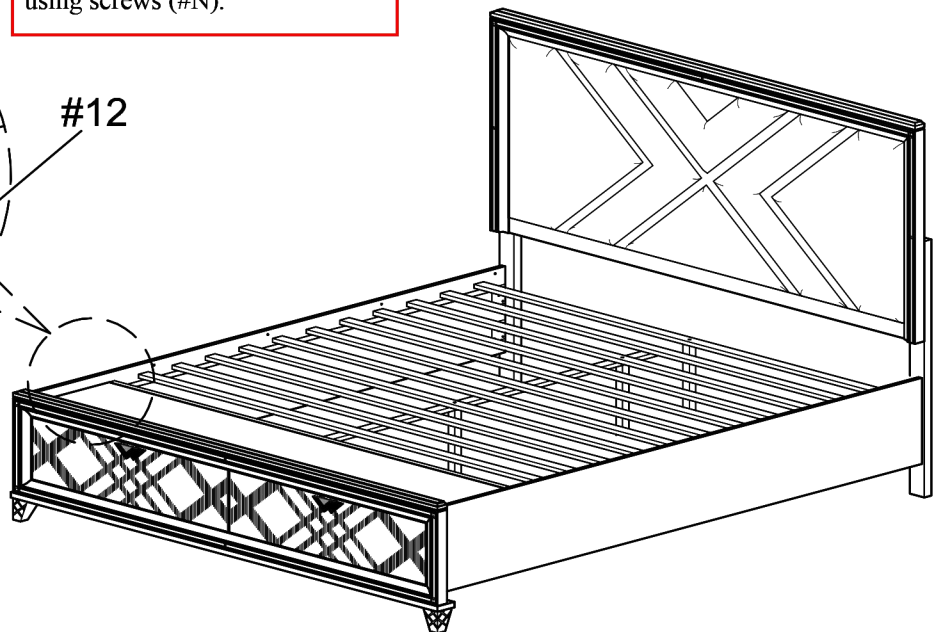
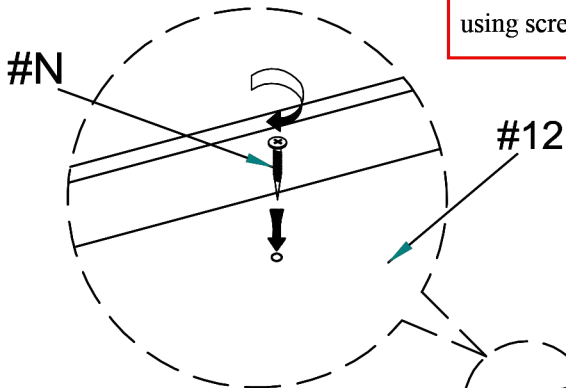

ASSEMBLY INSTRUCTIONS

13

Part (#15) x 2pcs

Hardware (#P) x 1pc

Hardware (#R) x 10pcs

Hardware (#S) x 10pcs

Hardware (#T) x 10pcs

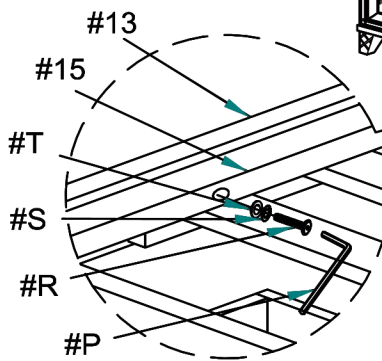
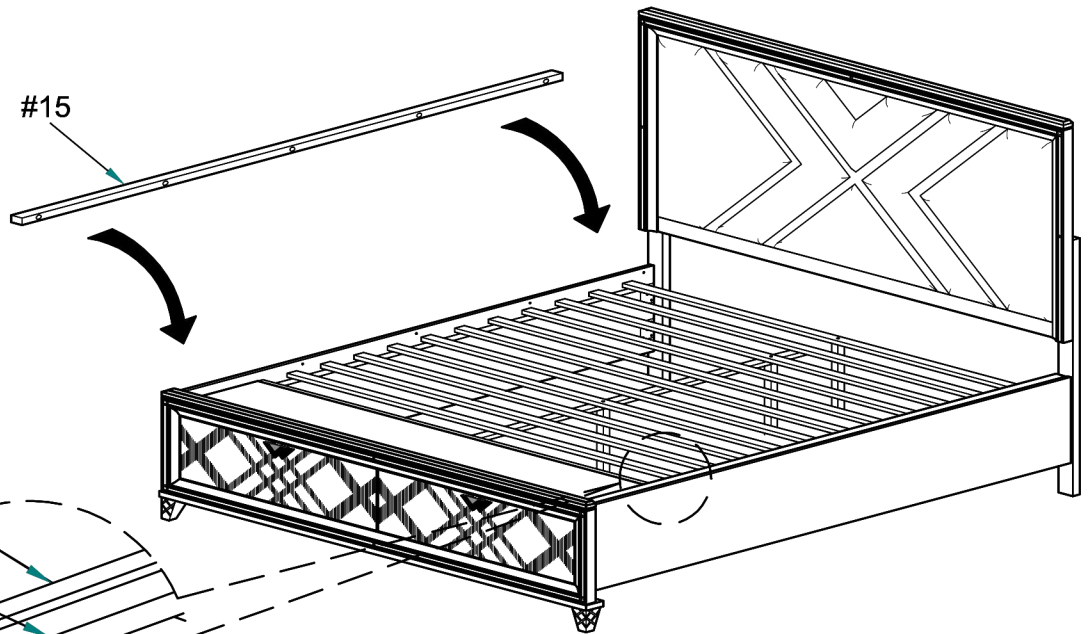

Align top cap (#15) to the side rails (#13), then secure by using bolts (#R) with washers (#S,T).

14

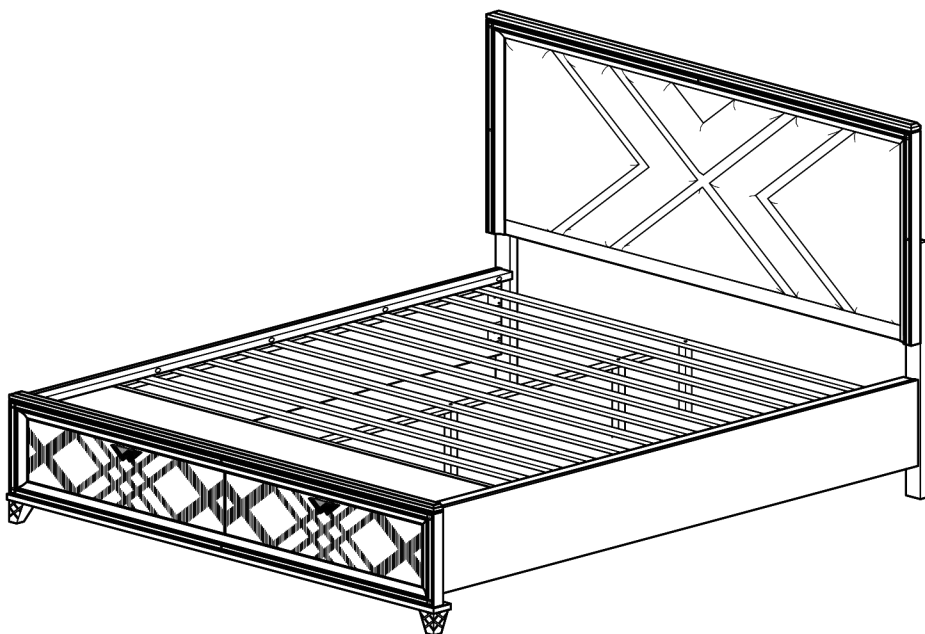

ASSEMBLY COMPLETED

Please ensure the furniture rests on an even and flat surface. If the product wobbles or feels loose, double-check all bolts and/or screws are properly tightened and secured.

✔ **Keep this handy!**

Please retain this instruction manual and any order-related information for future reference.

✔ **Lift, don't drag!**

To avoid damage to product please always LIFT the product when transporting or adjusting the placement.

ASSEMBLY INSTRUCTIONS

TOOLS REQUIRED

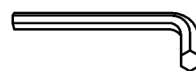

Allen Wrench

(Included)



Phillips
Screwdriver

(Not Included)

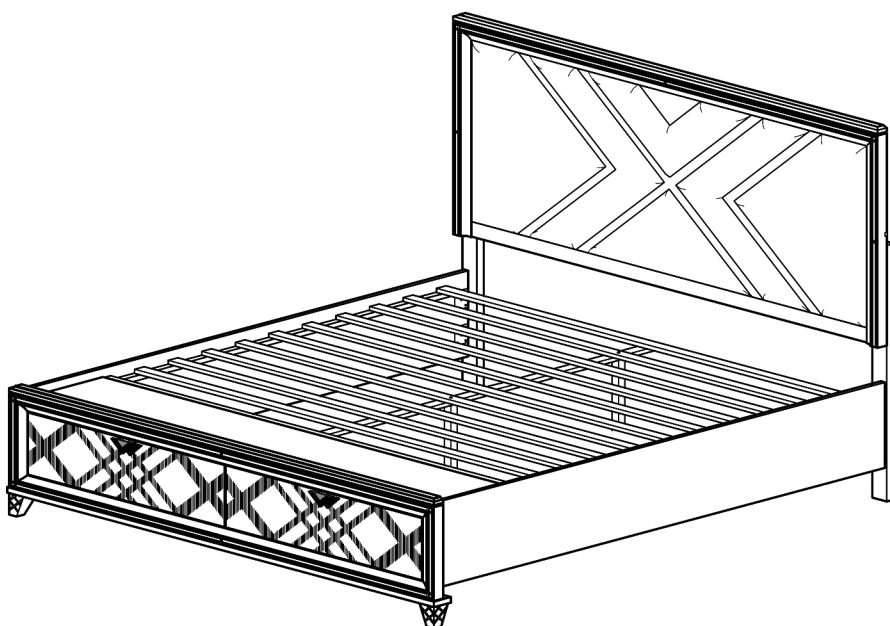

3 - People
Recommended

ASSEMBLY RATING



EASY —————> DIFFICULT

The Assembly Rating is a 5-point system showing the level of effort needed to assemble a specific product.



CHECK BEFORE STARTING

Are you missing anything?

Double-check all parts, hardware and accessories listed on Page 6 are accounted for.

Check out our Quick Tips!

We recommend reviewing the pre-assembly handouts. Even experts need a refresher now and then!

Should we send any replacements?

Are there any irregularities or flaws in the parts? We can send replacements!

Prep Time!

Please review the assembly instructions and all diagrams prior to assembling. Arrange parts as recommended on Page 7 and group identical hardware together to make assembling easier.

PRE ASSEMBLY INTRODUCTION

We understand building ready-to-assemble furniture can be a challenging experience for some. To help avoid confusion, we have provided some helpful tips that may speed up the process.

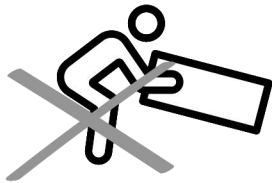

Teamwork

ALWAYS have at least two people to help with transporting and assembling the product to avoid potential injury and/or damage.

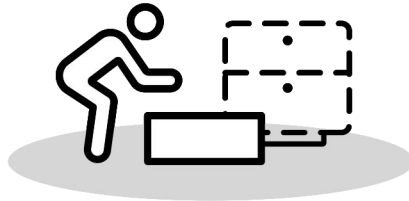
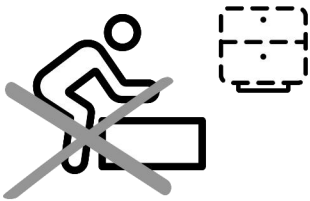

Suitable Location

Assembling near the area of the intended location is highly recommended.



Sufficient Space

Make sure you have enough space to move around during the assembly.

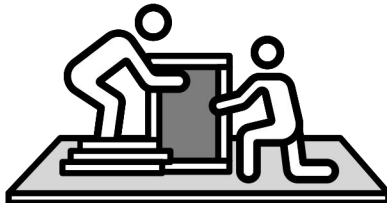

Avoid Scratches

Use cardboard, blankets or a carpeted area while assembling furniture to prevent scratches.

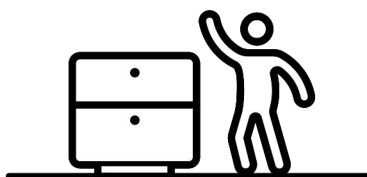
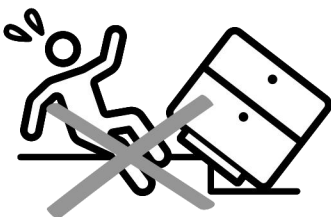

Flat Surface

Make sure the furniture rests on a flat and level surface with each leg evenly touching the floor.

ASSEMBLY AND CARE ADVICE



FAILURE TO FOLLOW THE GUIDELINES BELOW MAY RESULT IN INJURY AND/OR PROPERTY DAMAGE.



Position each part correctly and insert screws or bolts into their respective holes.

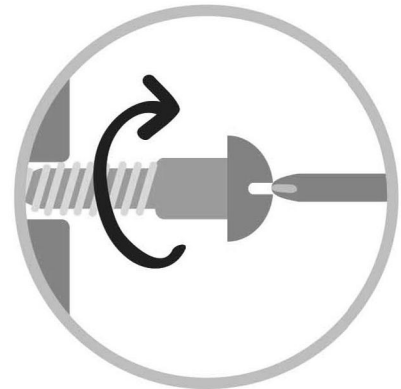

Turn clockwise to tighten and only tighten when step is completed or when instructed to do so.



Save the instructions and store any supplied tools for later maintenance.

Use the appropriate hand tools or power tools for assembly. Select steps, such as tightening screws and/or bolts, may require hand tools to avoid causing damage during assembly.



After two weeks, check and tighten any loose hardware and repeat again every six months thereafter.

IT IS THE USER'S RESPONSIBILITY TO MAINTAIN THE FURNITURE. THE HARDWARE MAY LOOSEN OVER TIME AND MAY CAUSE THE FURNITURE TO BE WOBBLY AND UNABLE TO SUPPORT ITS INTENDED WEIGHT CAPACITY. THIS MAY LEAD TO COLLAPSE AND MAY CAUSE SERIOUS INJURY.

KING BED



• Please keep instructions for future reference.
 • Check the quantity and irregularity of parts and hardware before you start.

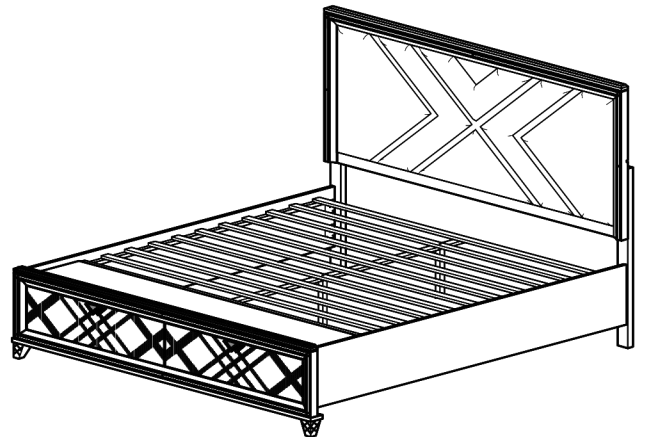

PARTS

PART LIST OF HEADBOARD

#1 1pc

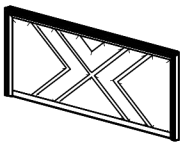

Headboard

#2 1pc

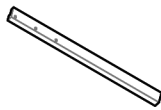

Headboard Leg - (R)

#3 1pc



Headboard Leg - (L)

PART LIST OF FOOTBOARD

#4 1pc

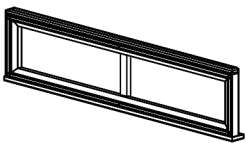

Footboard

#5 2pcs



Acrylic Leg

#6 1pc



Drawer Support Rail

#7 2pcs



Drawer

#8 2pcs

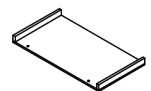

Drawer Base Panel

#9 13pcs

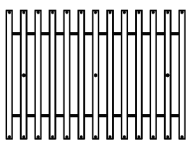

Roll Slat

#10 3pcs



Slat Support Leg
440mm x 30mm x 30mm

#11 1pc



Drawer Support Leg

#12 1pc

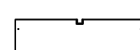

Slat Cover Panel

PART LIST OF SIDE RAIL

#13 2pcs



Side Rail

#14 1pc



Center Vertical Slat

HARDWARE

HARDWARE PACK IN HEADBOARD

#A 1pc



Allen Key

#B 6pcs



JCBC - M6 x 40mm

#C 6pcs



M6 Spring Washer

#D 6pcs



M6 Flat Washer

#E 1pc



AC Adapter

HARDWARE PACK IN FOOTBOARD

#F 1pc



Allen Key

#G 2pcs



JCBC - M6 x 16mm

#H 9pcs



JCBC - M6 x 35mm

#I 3pcs



JCBC - M6 x 60mm

#J 14pcs



M6 Spring Washer

#K 7pcs



M6 Flat Washer

#L 4pcs



1/4" Flat Washer

#M 26pcs



Screw 32mm

#N 2pcs











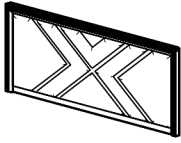
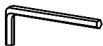

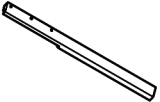

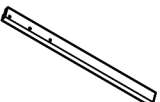

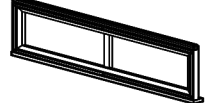
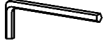





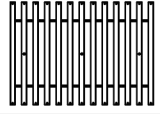

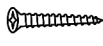

Screw 16mm

#O 4pcs

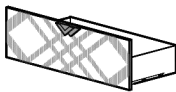
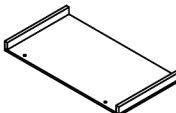

Adjustable Leveller

Carton	Designation		Part	Hardware
	Headboard (1pc)	#1		 #A x 1pc  #B x 6pcs
	Headboard Leg - (R) (1pc)	#2		 #C x 6pcs  #D x 6pcs
	Headboard Leg - (L) (1pc)	#3		 #E x 1pc
	Footboard (1pc)	#4		 #F x 1pc
	Acrylic Leg (2pcs)	#5		 #G x 2pcs  #H x 9pcs
	Drawer Support Rail (1pc)	#6		 #I x 3pcs
	Roll Slat (13pcs)	#9		 #J x 14pcs  #K x 7pcs
	Slat Support Leg (3pcs)	#10		 #L x 4pcs
	Drawer Support Leg (1pc)	#11		 #M x 26pcs  #N x 2pcs
	Slat Cover Panel (1pc)	#12		 #O x 4pcs
	Side Rail (2pcs)	#13		
	Center Vertical Slat (1pc)	#14		
	Drawer (2pcs)	#7		
	Drawer Base Panel (2pcs)	#8		

ASSEMBLY INSTRUCTIONS

1

Part #1 x 1pc

Part #2 x 1pc

Part #3 x 1pc

Hardware #A x 1pc

Hardware #B x 6pcs

Hardware #C x 6pcs

Hardware #D x 6pcs

Hardware #E x 1pc

Align HB legs (#2,3) to the headboard (#1), then secure by using bolts (#B) with washers (#C,D).

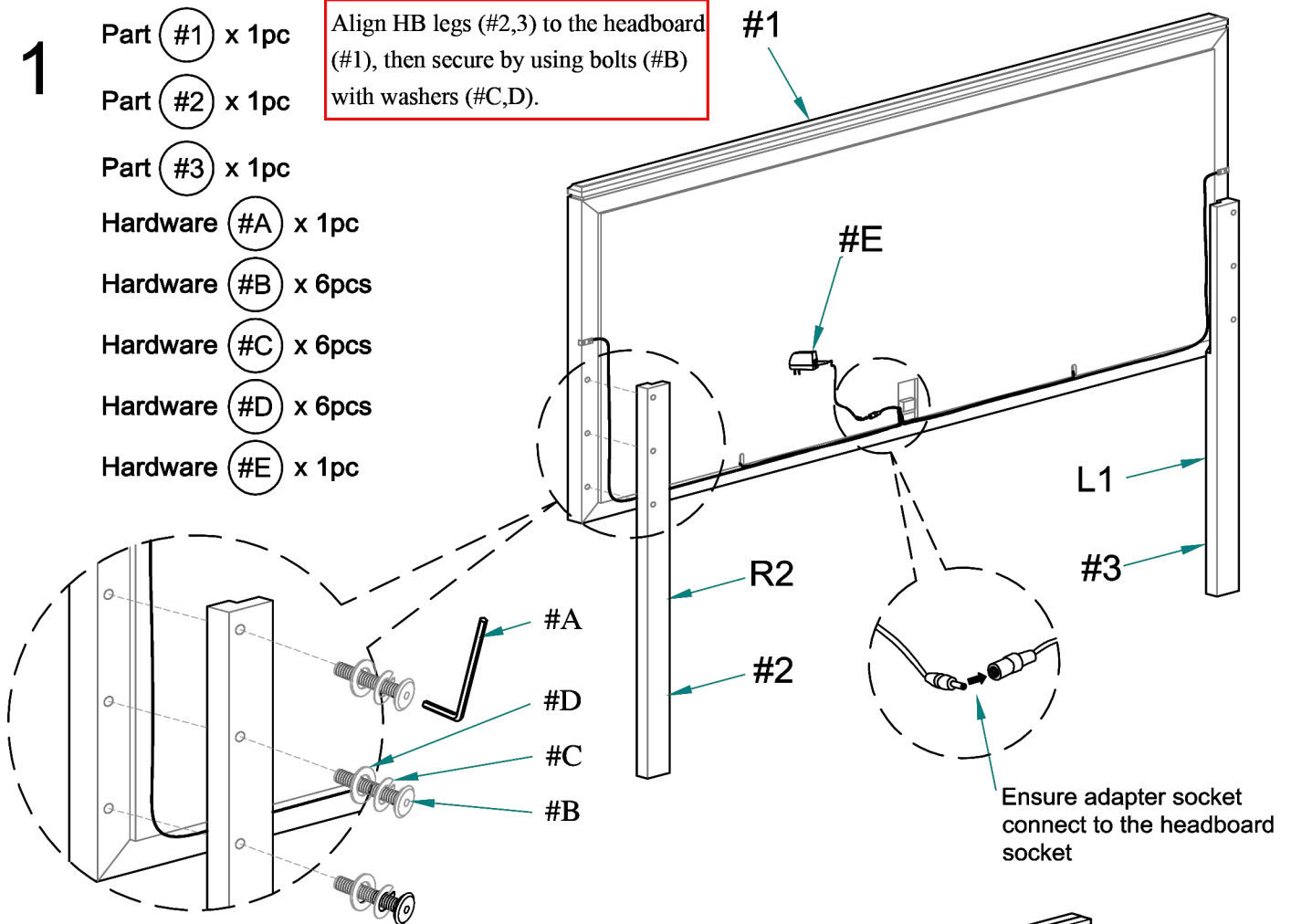

2

Part #1 x 1pc

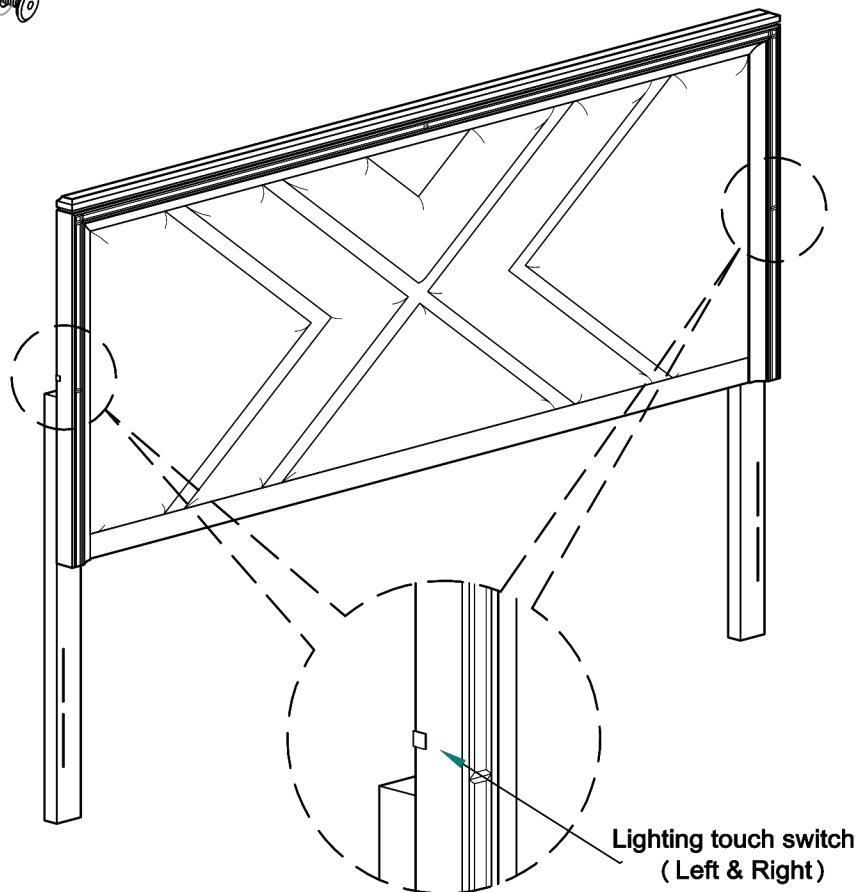

ASSEMBLY INSTRUCTIONS

3

Part #4 x 1pc

Part #5 x 2pcs

Acrylic Leg cover

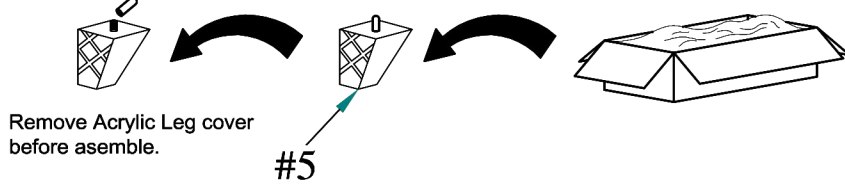

Attach legs (#5) to footboard (#4).

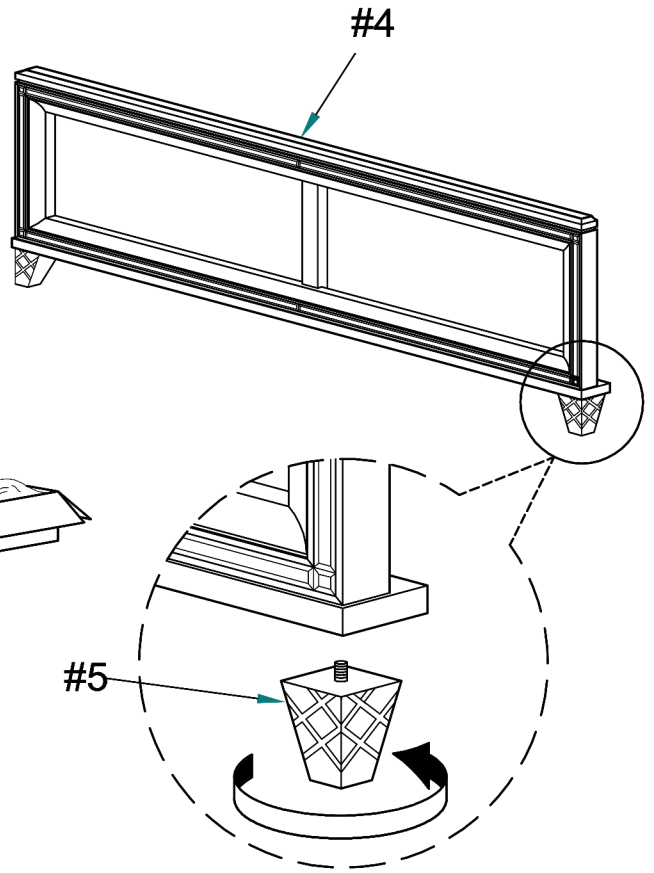

4

Part #1 x 1pc

Part #4 x 1pc

Part #13 x 2pcs

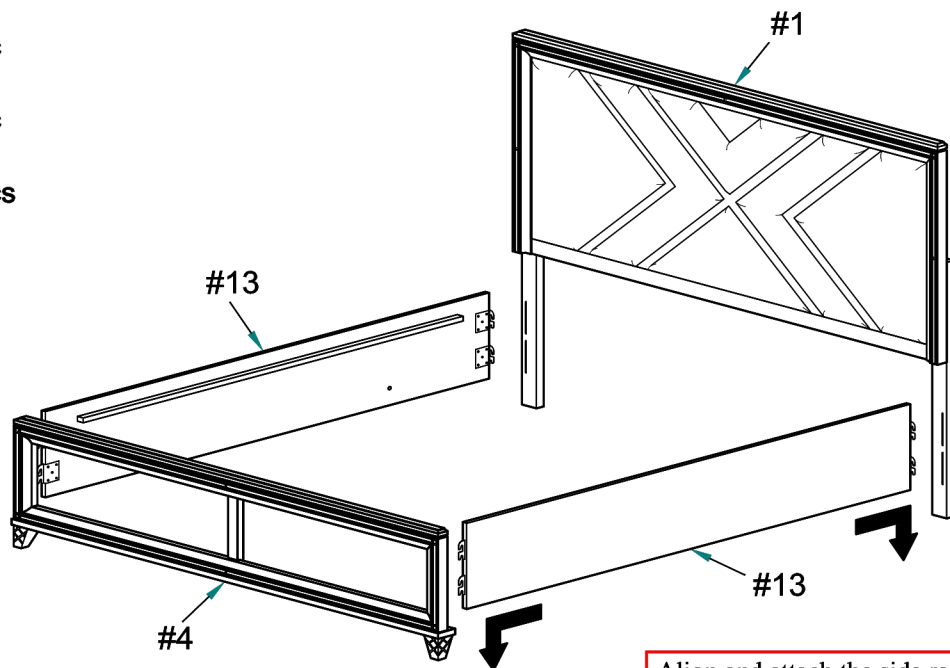

Align and attach the side rails (#13) to the headboard (#1) and footboard (#4).

ASSEMBLY INSTRUCTIONS

5

Part (#6) x 1pc

Hardware (#F) x 1pc

Hardware (#G) x 2pcs

Hardware (#J) x 2pcs

Hardware (#K) x 2pcs

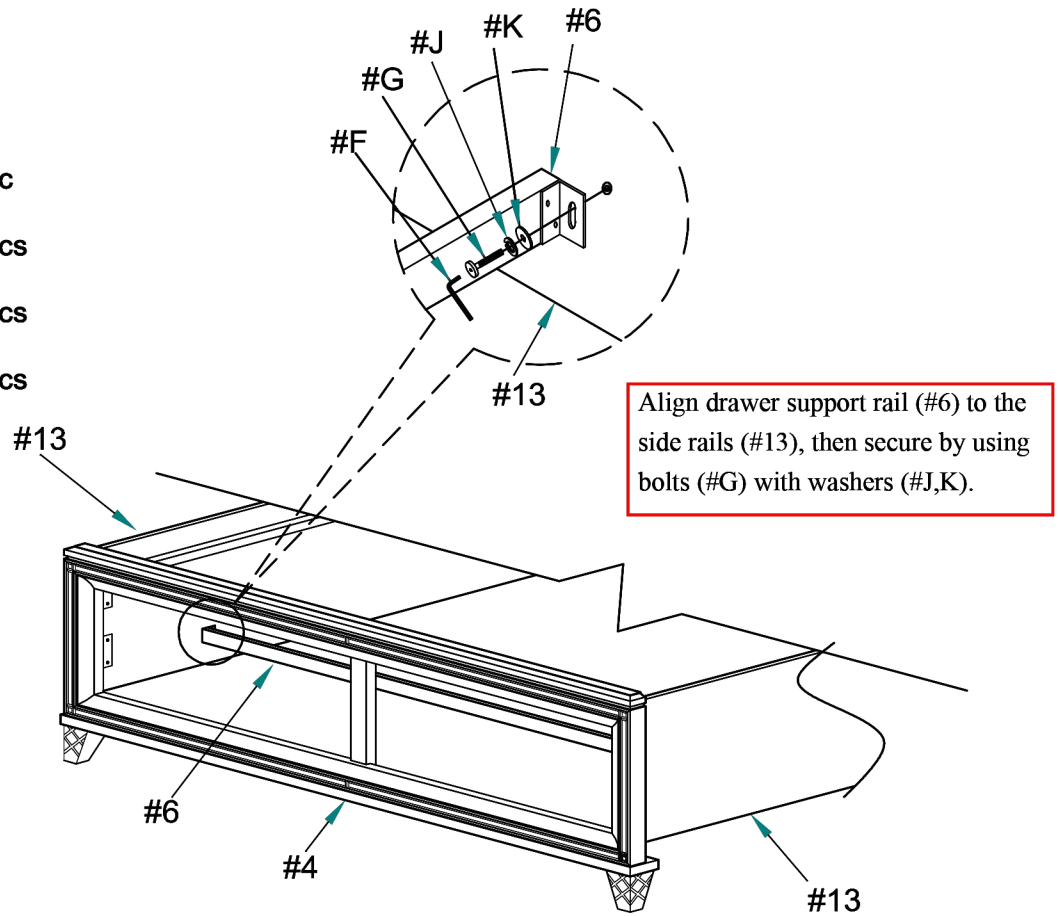

6

Make sure to fully extend rails to see the black switch on the rails.

Step to remove the drawer :

1. Pull the drawer
2. Using both hands,
 - Left hands side - pull up switch
 - Right hands side - pull down switch
3. Then remove the drawer from the drawer base panel

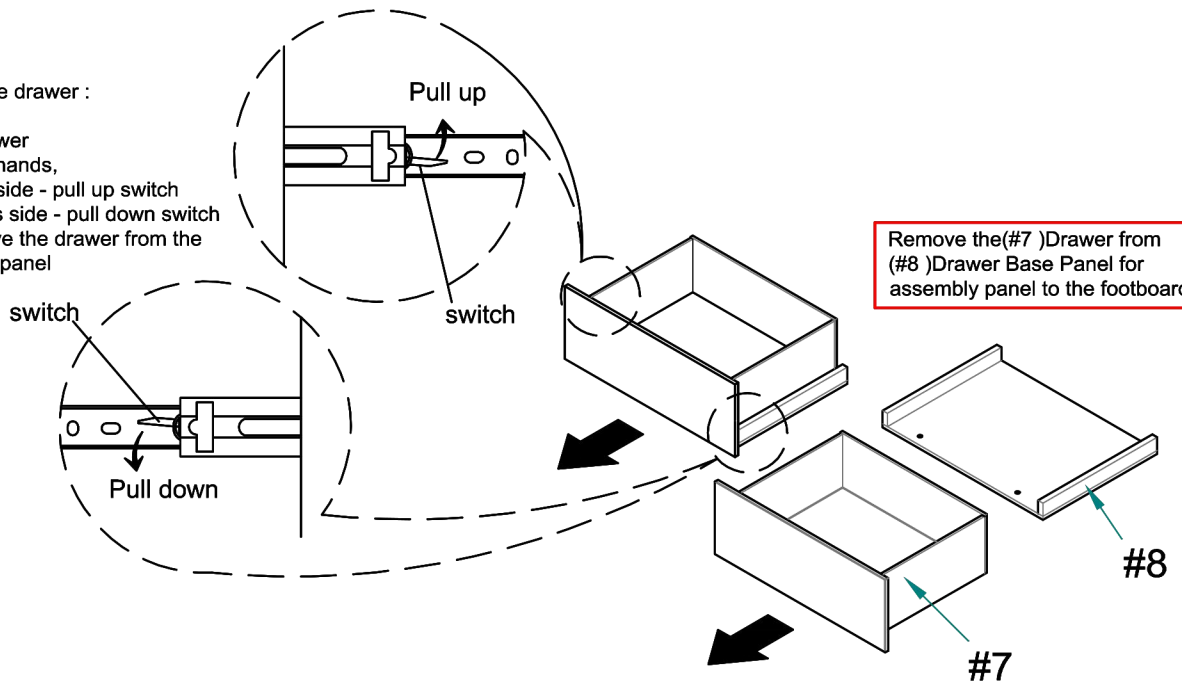

ASSEMBLY INSTRUCTIONS

7

- Part (#8) x 2pcs Hardware (#F) x 1pc
 Hardware (#H) x 8pcs
 Hardware (#J) x 8pcs
 Hardware (#K) x 4pcs
 Hardware (#L) x 4pcs

Align drawer base panel (#8) to the footboard, then secure by using bolts (#H) with washers (#J,K,L) as shown in the diagrams.

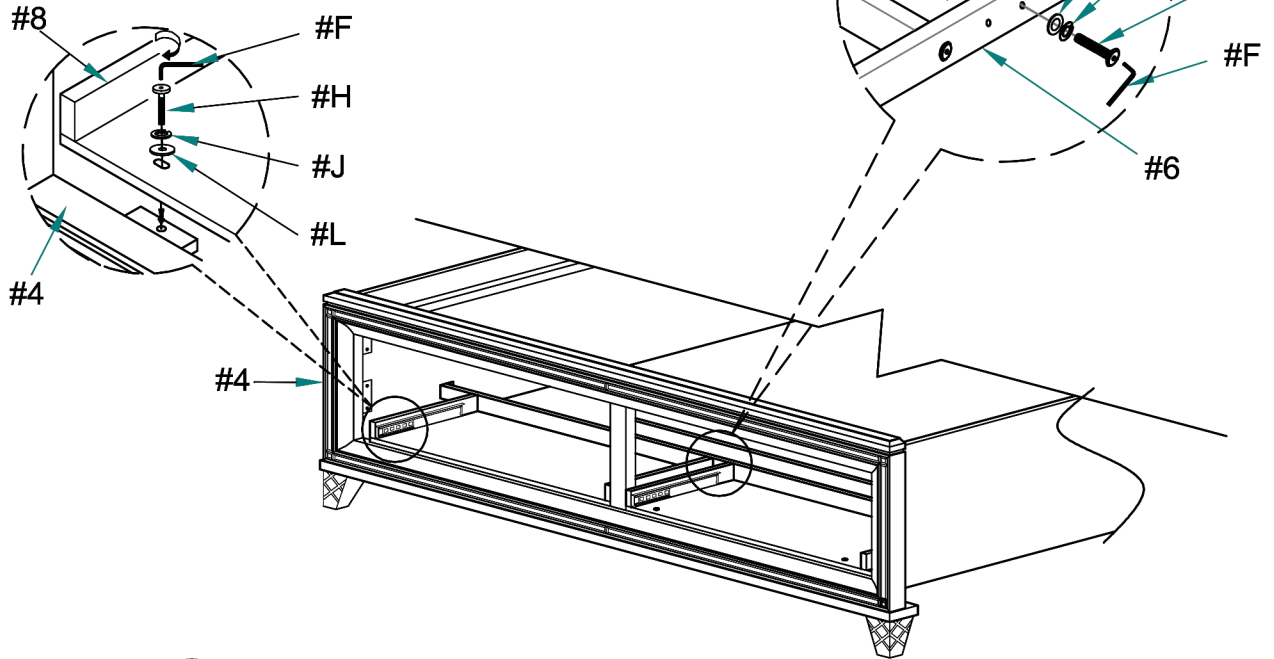

8

- Part (#11) x 1pc
 Hardware (#F) x 1pc
 Hardware (#H) x 1pc
 Hardware (#J) x 1pc
 Hardware (#K) x 1pc
 Hardware (#O) x 1pc

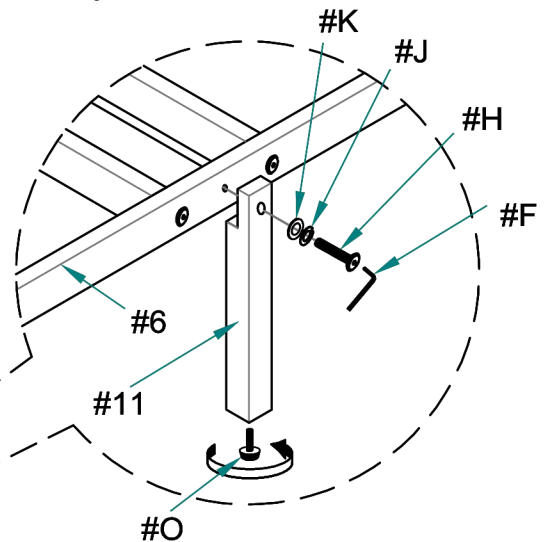

Align drawer support leg (#11), then secure by using bolts (#H) with washers (#J,K).

ASSEMBLY INSTRUCTIONS

9

Part (#7) x 2pcs

Step to install the drawer on the drawer base panel :

***Prefer 2 person to install the drawer

1. Adjust the ball bearing plate to the front as a diagram shows.
2. Then attach the drawer to the drawer base panel and install with carefully.

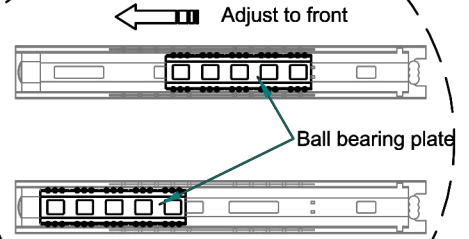

Insert the drawer (#7) to the footboard (#4)

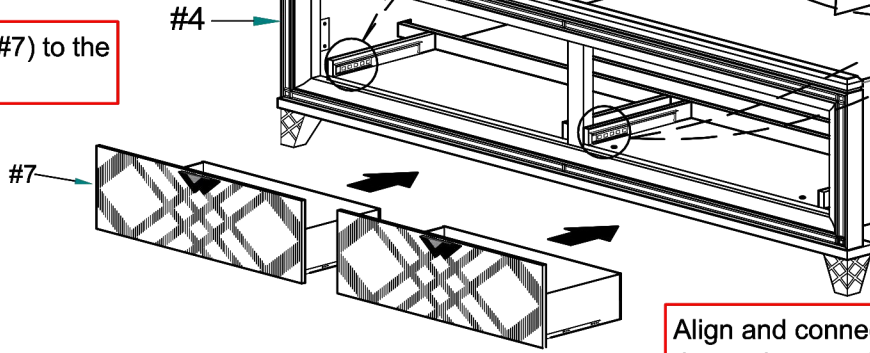

Align and connect the rails of the drawer base to the drawers.

10

- | | |
|-------------------|-----------------------|
| Part (#9) x 13pcs | Hardware (#F) x 1pc |
| Part (#10) x 3pcs | Hardware (#I) x 3pcs |
| Part (#12) x 1pc | Hardware (#J) x 3pcs |
| Part (#14) x 1pc | Hardware (#M) x 26pcs |
| | Hardware (#O) x 3pcs |

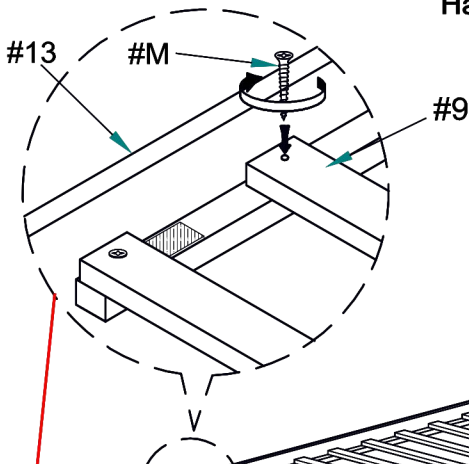

Align slats (#9) to the side rails (#13), then secure by using screws (#M).

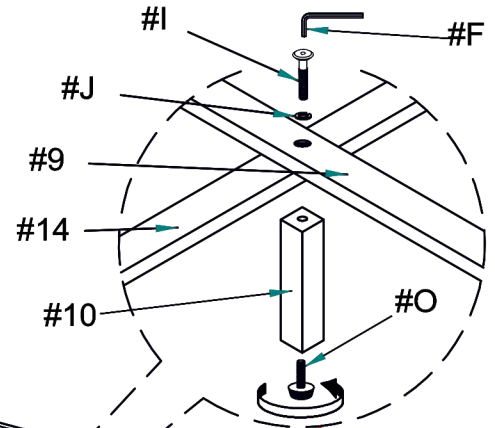

Align slat support (#14) to the slats (#9), then secure by using bolts (#I) with washers (#J) directly onto support leg (#10) as shown in the diagram.

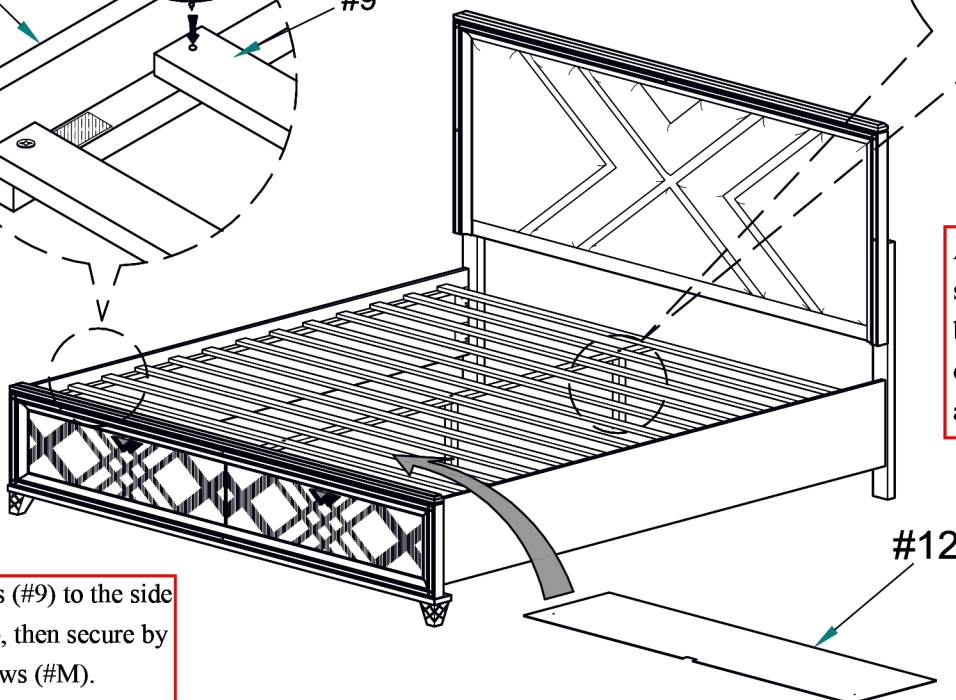

ASSEMBLY INSTRUCTIONS

11 Hardware (#N) x 2pcs

Align slat cover panel (#12) to the bottom slats, then secure by using screws (#N)

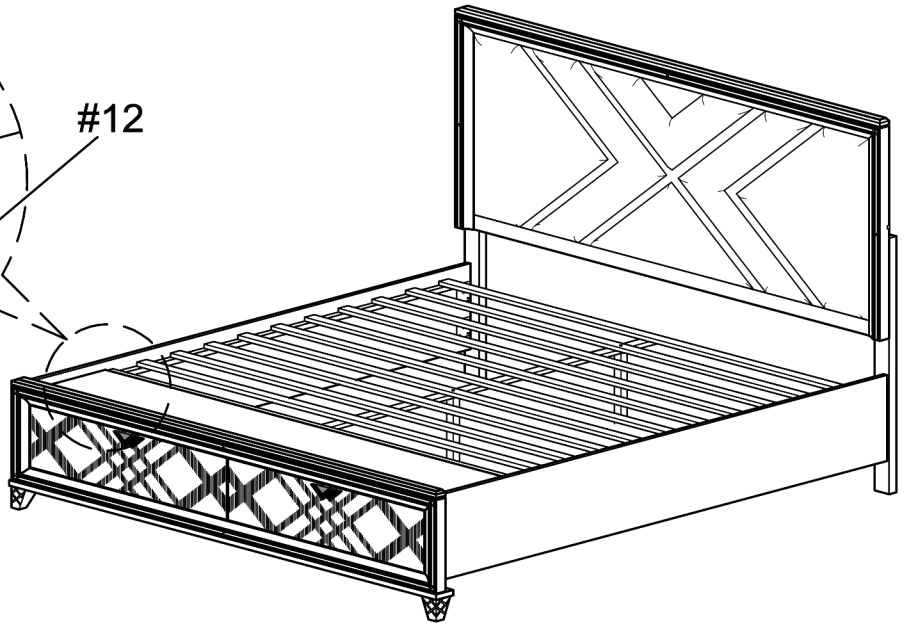
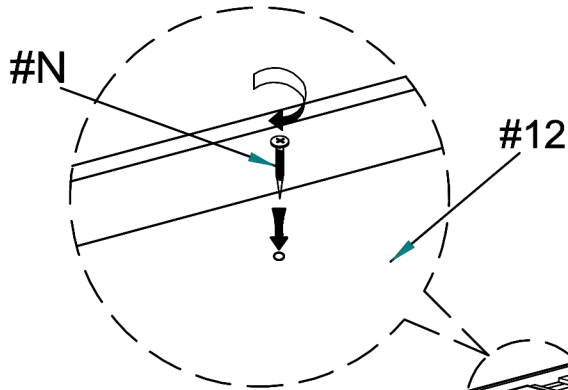

12

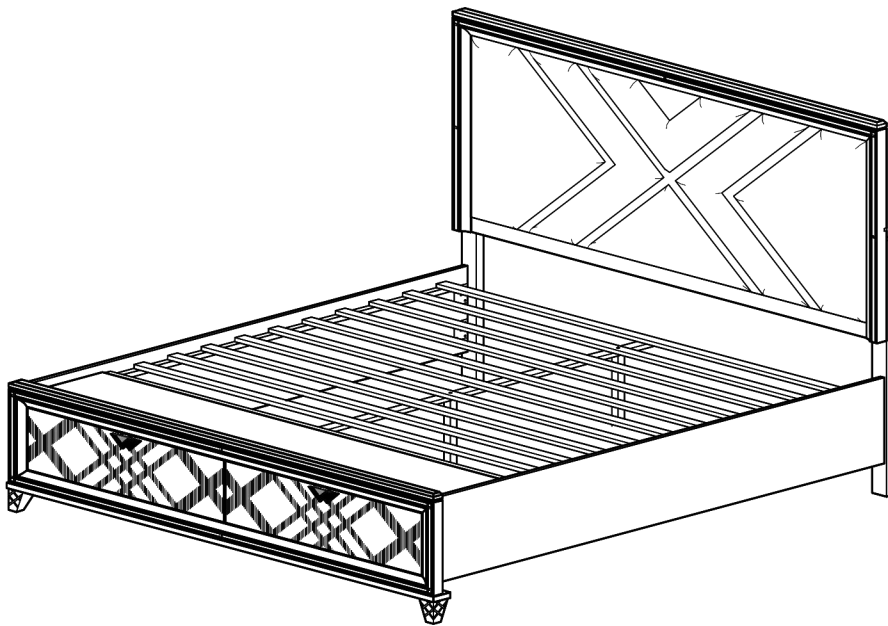

ASSEMBLY COMPLETED



Please ensure the furniture rests on an even and flat surface. If the product wobbles or feels loose, double-check all bolts and/or screws are properly tightened and secured.



Keep this handy!

Please retain this instruction manual and any order-related information for future reference.



Lift, don't drag!

To avoid damage to product please always LIFT the product when transporting or adjusting the placement.