

# Installation instruction

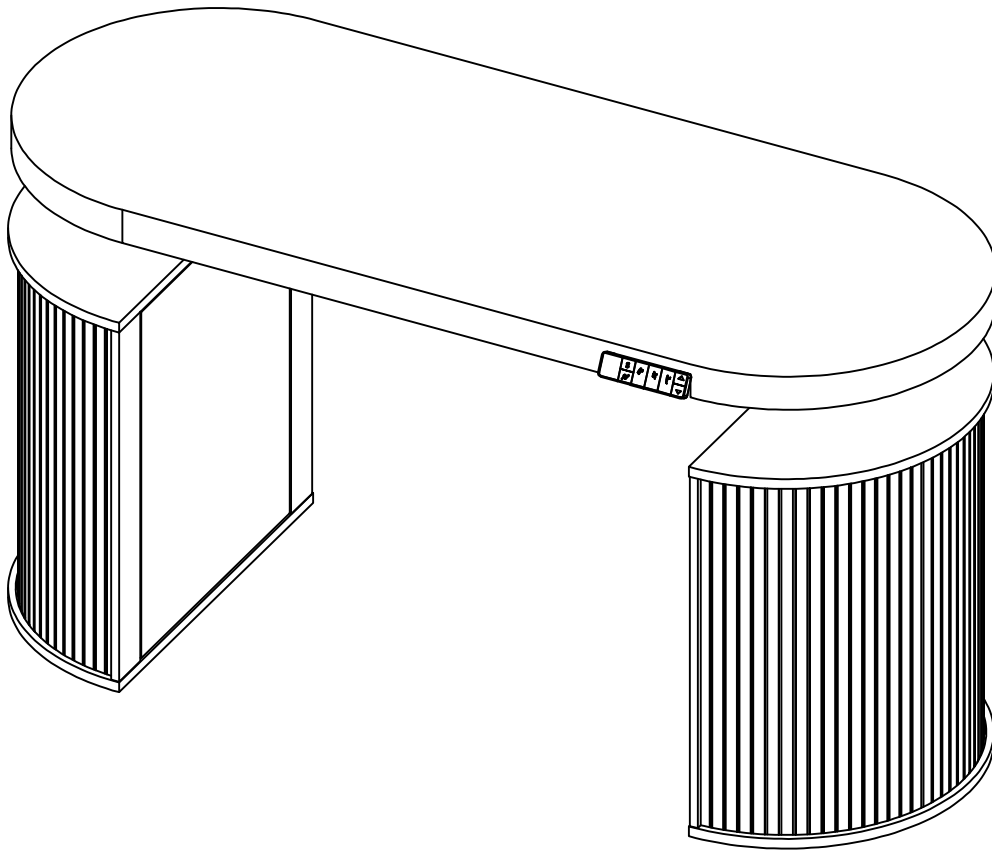

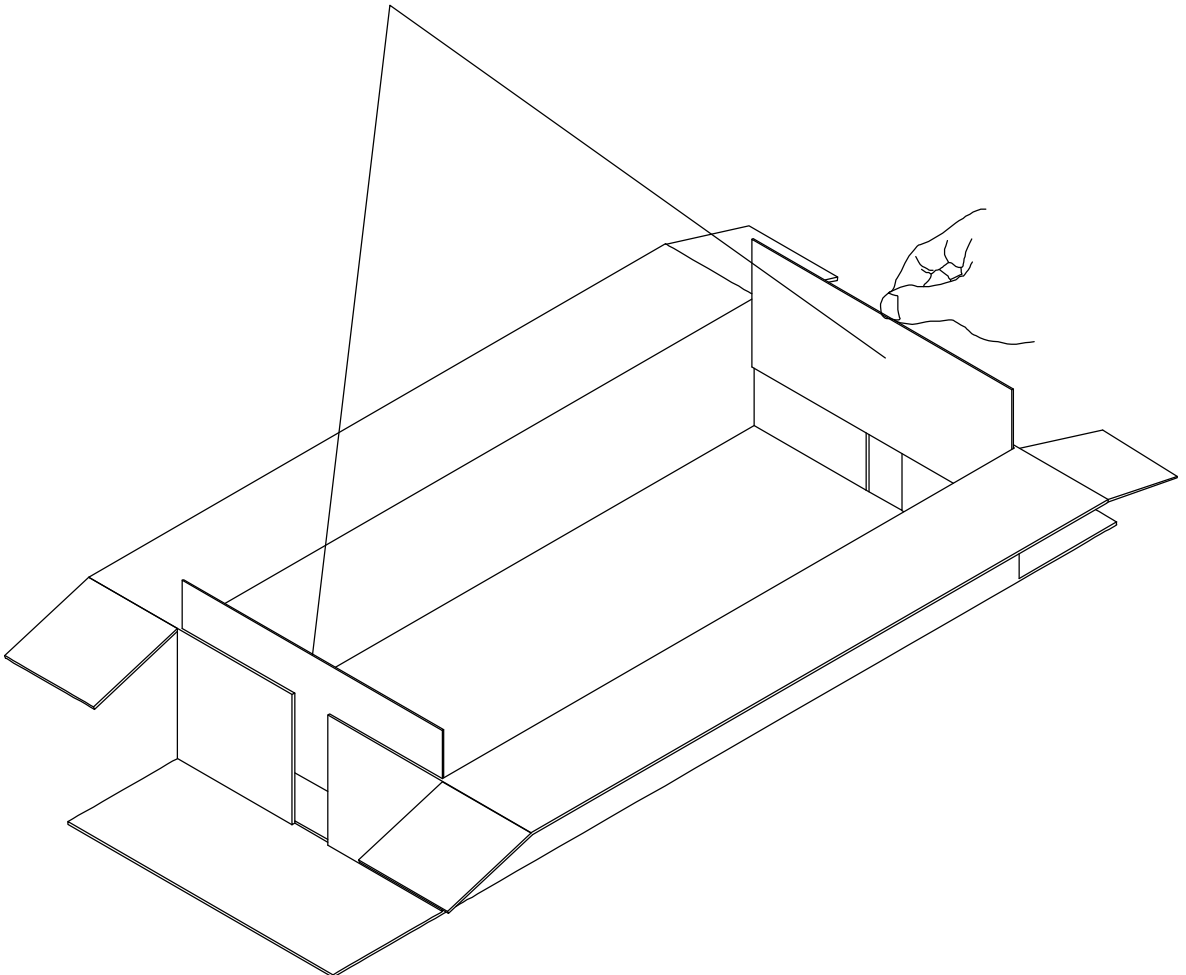

The two panels on the left and right of the package are used to protect the product, you can just throw it away.



# Assembling

---

## What you need

- Use the packaging carton as a working surface to prevent product damage during assembly

Tool Required Not Provided

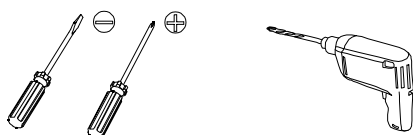

Use electric tools with care.

---



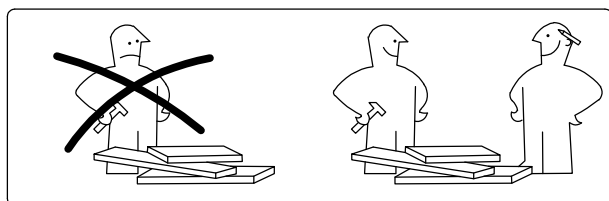







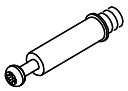
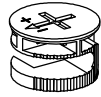
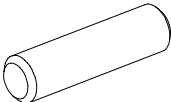

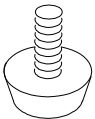

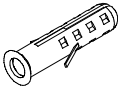

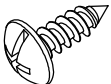
## Weight Limitation

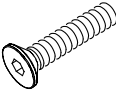

# What' included

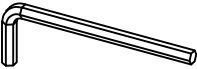
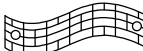
Code	Description	Qty
A	Cam Bolt M6X35MM	24
B	Cam Lock 15X10MM	24
C	Wooden Dowel M8X30MM	8
D	Screw M3.5X14MM	28
E	Screw M4X35MM	30
F	Adjustable Leveler	6
G	Door Rebound Device	2
H	Expansion tube	2
I	Screw M5X15MM	4
J	Spring compressor	2
K	Screw M5X14MM	12
L	Screw M6X16MM	12
M	Screw M6X35MM	8
N	Screw M4X25MM	2
O	Plastic post	2
P	Screw wrench	1
Q	Screw wrench	1
R	Screw wrench	1
S	Nylon Strap	2
T	Pivoting rod connector	1
U	Electric motor	1
V	Door panel hinge	4
W	Motor controller	1
X	Converter	1

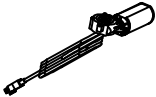
# The Hardware

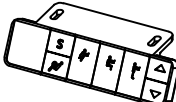
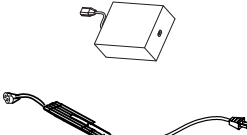
<p>A x 24</p>  <p>Ø6×35 mm</p>	<p>B x 24</p>  <p>Ø15×10 mm</p>	<p>C x 8</p>  <p>Ø8×30 mm</p>	<p>D x 28</p>  <p>Ø3.5×14 mm</p>	<p>E x 30</p>  <p>Ø4×35 mm</p>
<p>F x 6</p> 	<p>G x 2</p> 	<p>H x 2</p> 	<p>I x 4</p>  <p>M5×15 mm</p>	<p>J x 2</p> 
<p>K x 12</p>  <p>Ø5×14 mm</p>	<p>L x 12</p>  <p>M6×16 mm</p>	<p>M x 8</p>  <p>M6×35 mm</p>	<p>N x 2</p>  <p>M4×25</p>	<p>O x 2</p> 
<p>P x 1</p>  <p>2 mm</p>	<p>Q x 1</p>  <p>3 mm</p>	<p>R x 1</p>  <p>4 mm</p>	<p>S x 2</p> 	<p>T x 1</p> 
<p>U x 1</p> 	<p>V x 4</p> 	<p>W x 1</p> 	<p>X x 1</p> 	

## IMPORTANT:

1. Do not tighten bolts / screws completely until all bolts / screws are lined up and inserted into holes.
2. Do not over tighten screws and bolts to avoid stripping
3. You can use a screwdriver or an electric tool (be careful when using an electric tool).

# Included Accessories

---

Code	Description	Qty
1	Panel	1
2	Upper left curved plate	1
3	Upper right curved plate	1
4	Intermediate laminate	2
5	Lower curved plate	2
6	Grooved thin plate	2
7	Side vertical plate	2
8	Outer vertical plate left	2
9	Outer vertical plate right	2
10	Left front vertical plate	1
11	Right front vertical plate	1
12	Left rear vertical plate	1
13	Right rear vertical plate	1
14	Door plank	2
15	The iron frame on the left	1
16	The iron frame on the right	1
17	Supporting iron sheet	2
18	Cossbar	2
19	Middle crossbar	1
20	Iron piece	2

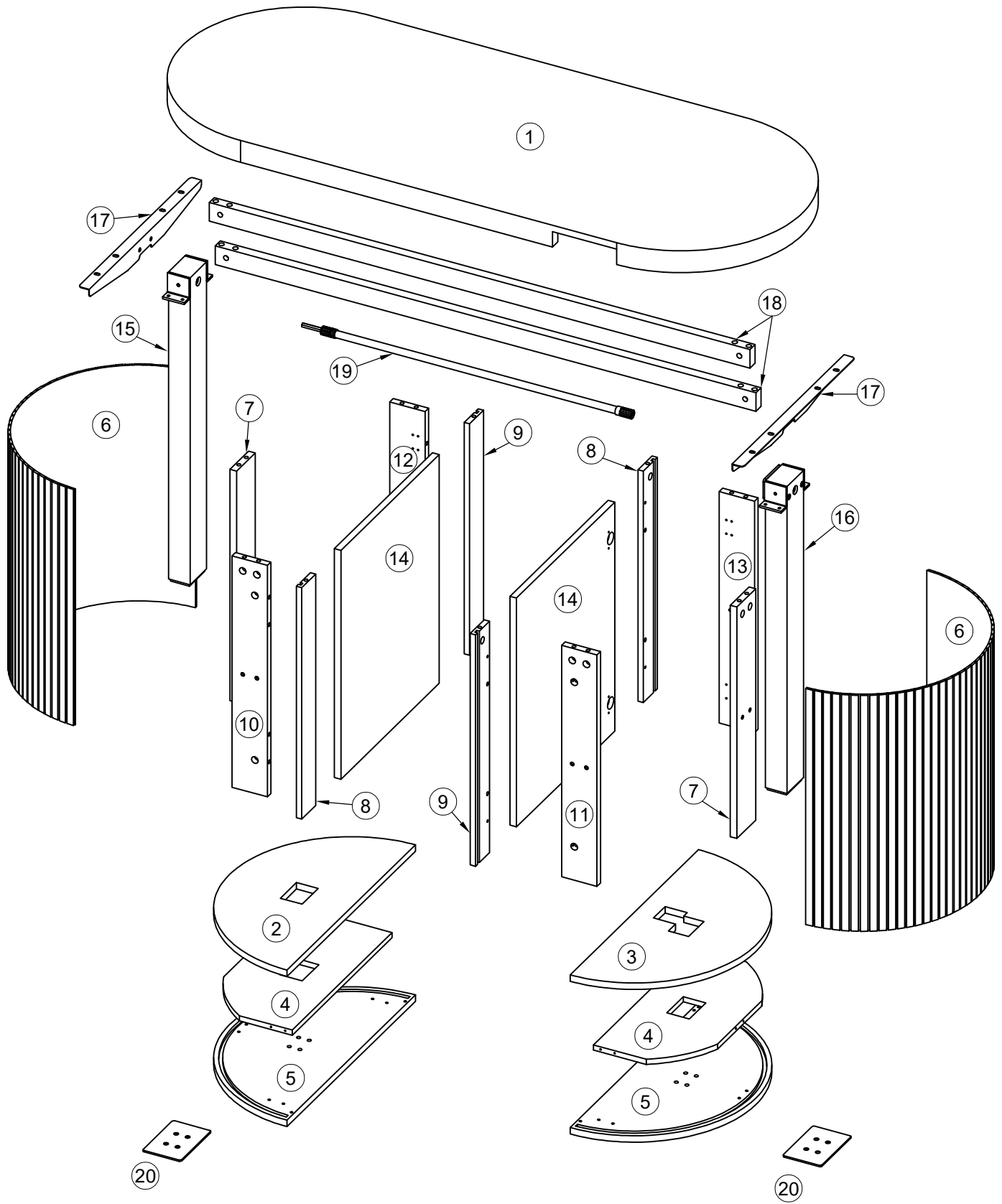

---

# The Accessories



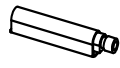

# Step 1

First, attach it to the wooden board, and then assemble J and K together.

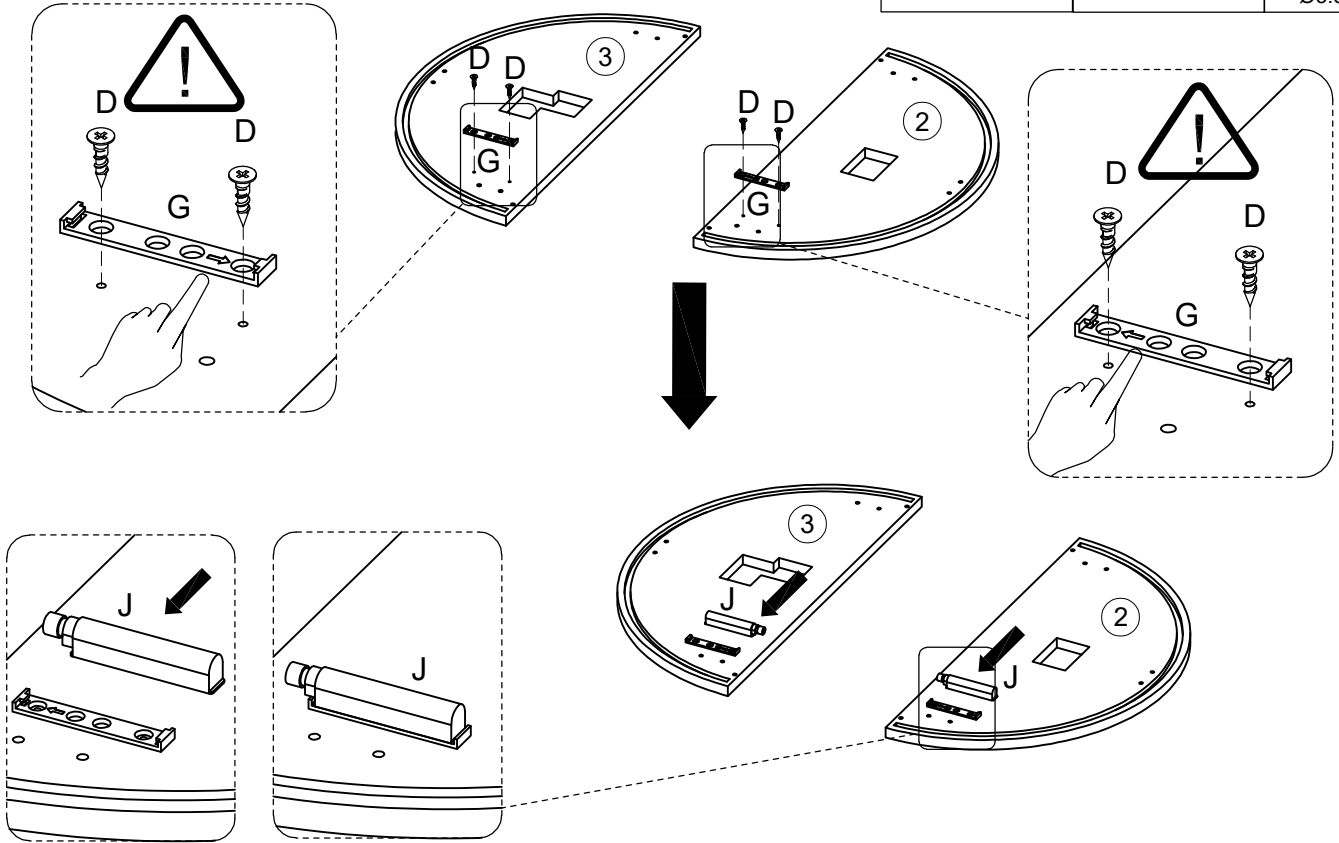
G x 2 	J x 2 	D x 4  Ø3.5x14 mm
--	--	--



# Step 2

C x 8  Ø8x30 mm	A x 24  Ø6x35 mm
--	---

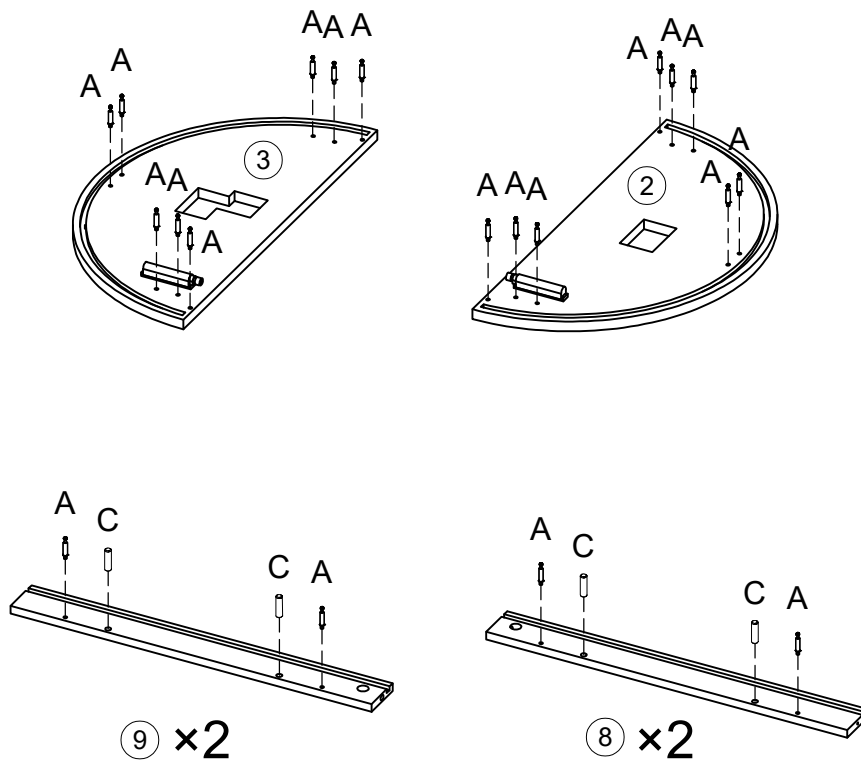

# Step 3

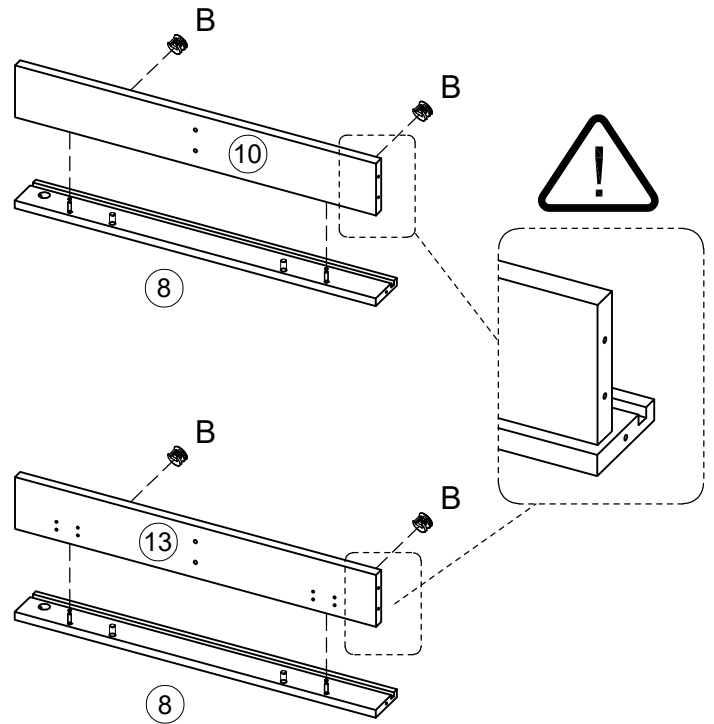
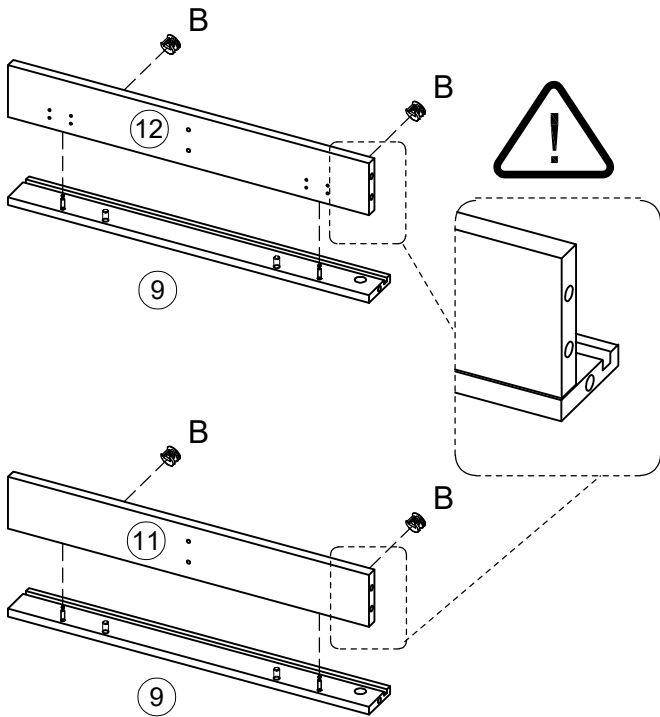
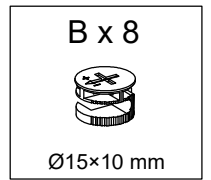

# Step 4

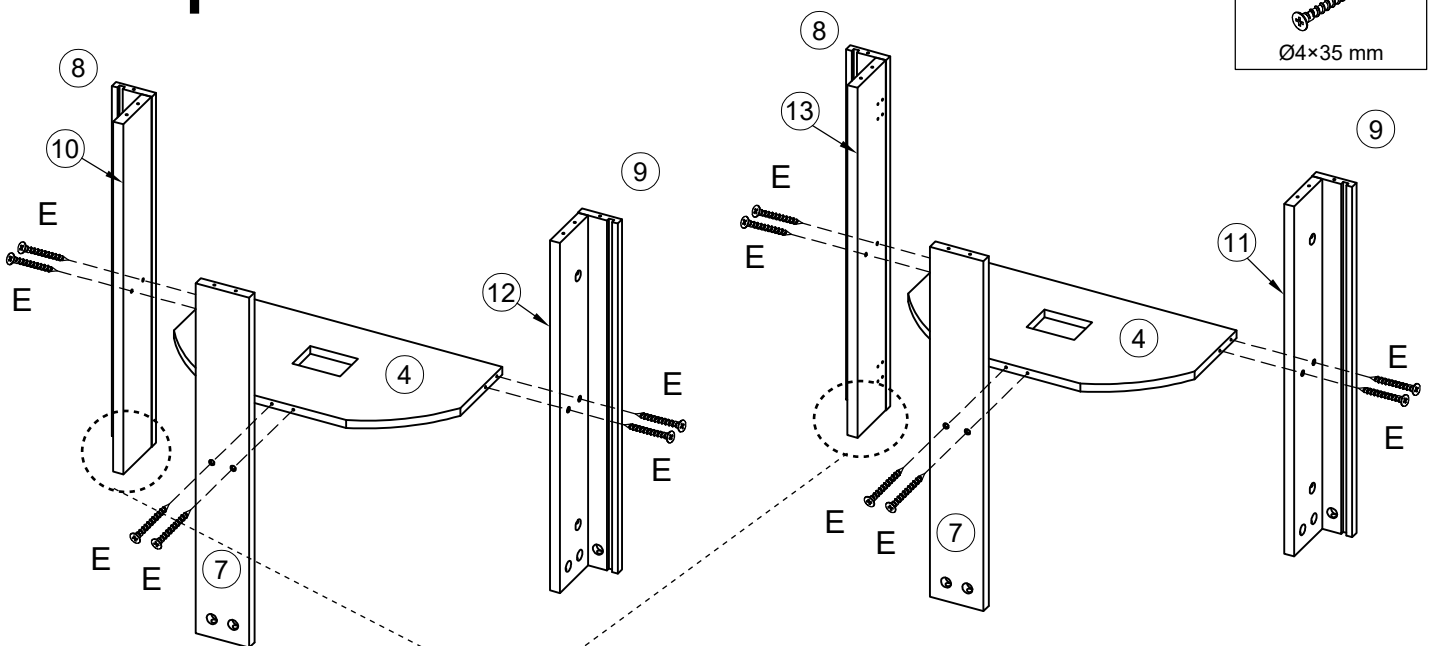
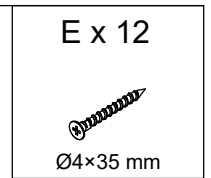

Install the eccentric wheel  
with the hole facing downward.

# Step 5

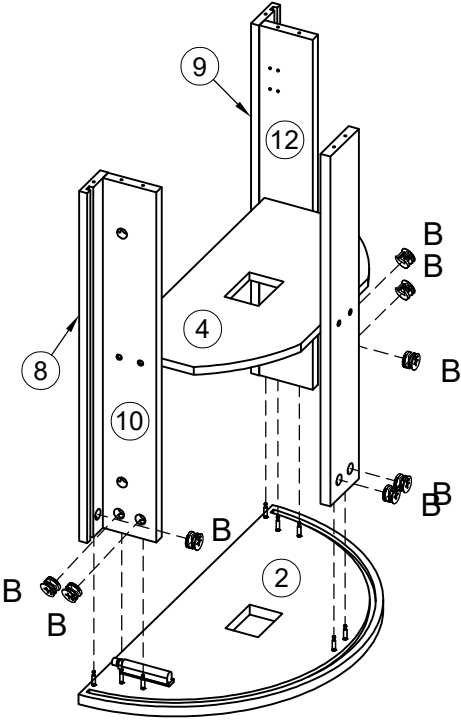
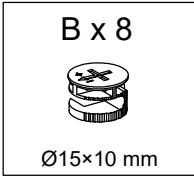

# Step 6

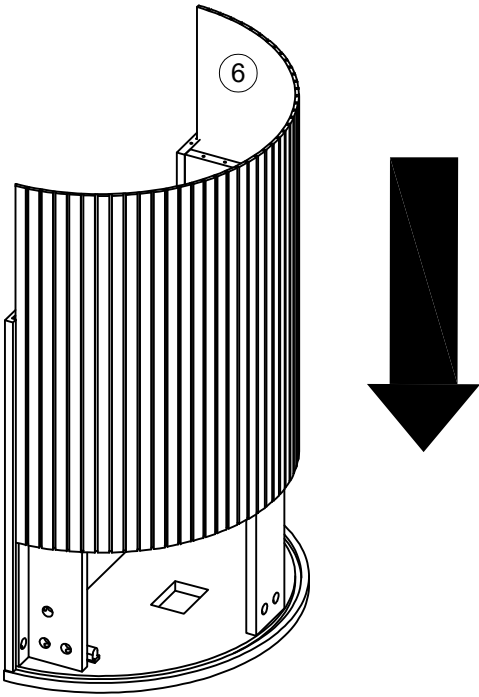

# Step 7

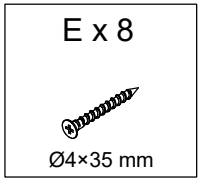
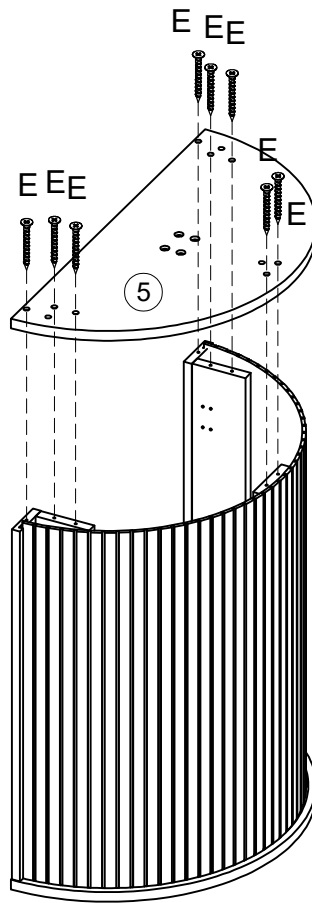

# Step 8

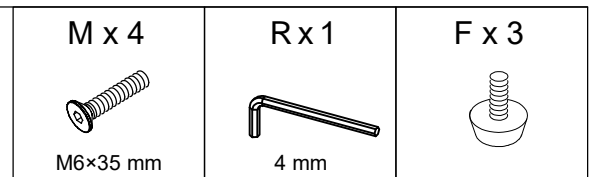

**Please note:** the side with only one hole is facing up.

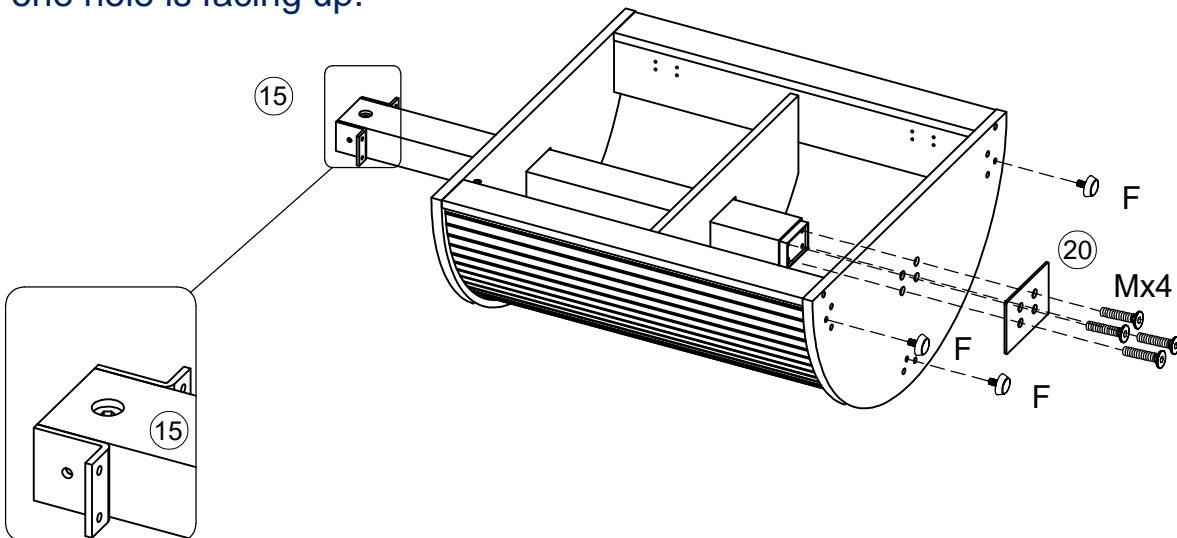

# Step 9

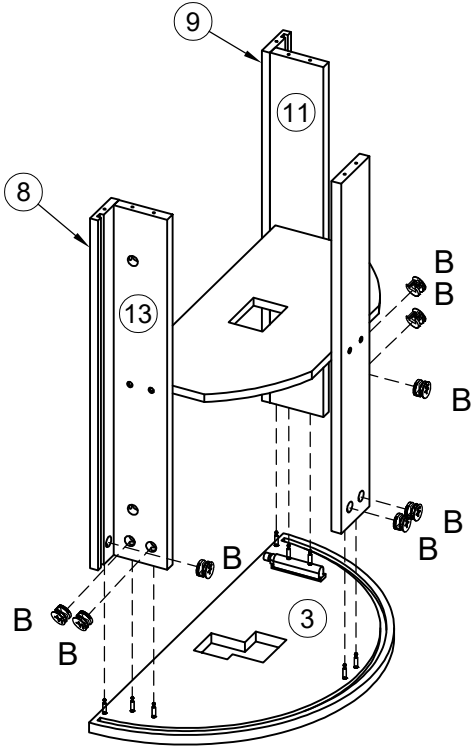
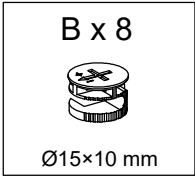

# Step 10

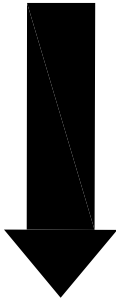
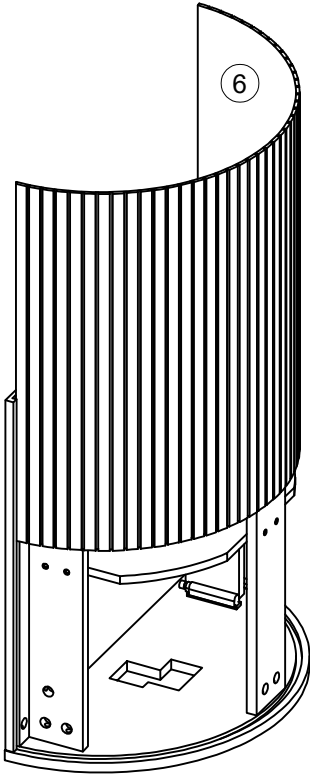

# Step 11

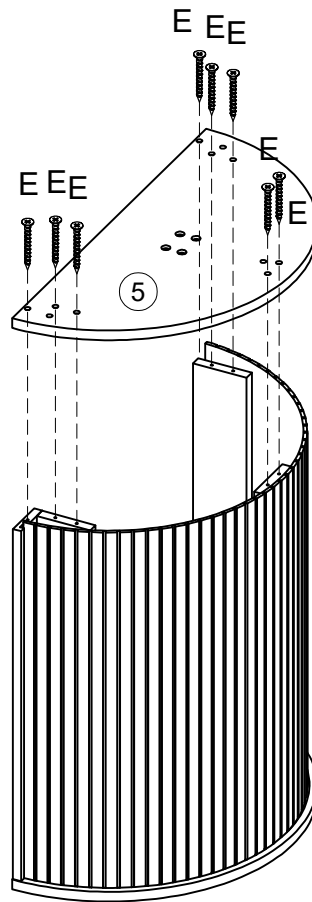
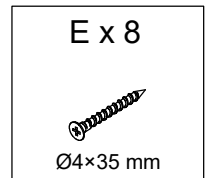

# Step 12

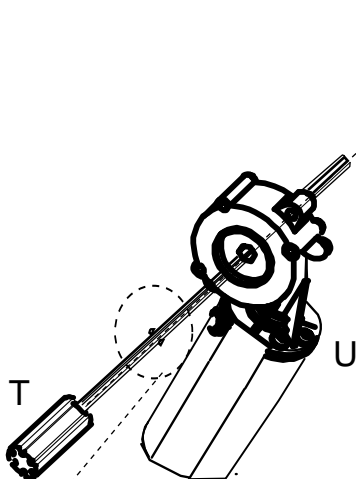
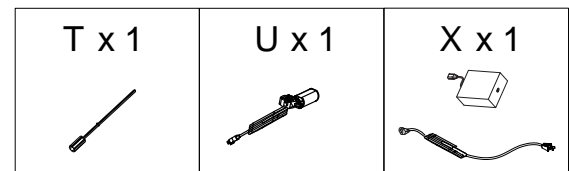

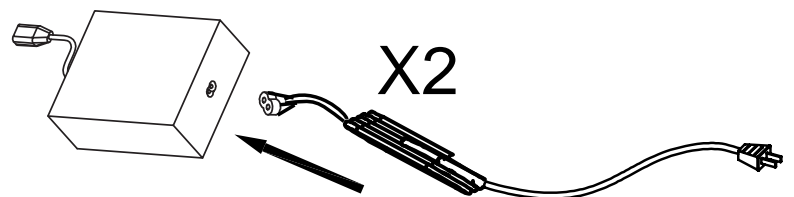

X1





Please insert the iron rod of the T component into the round hole of the U component until this bump snaps into place.

# Step 13

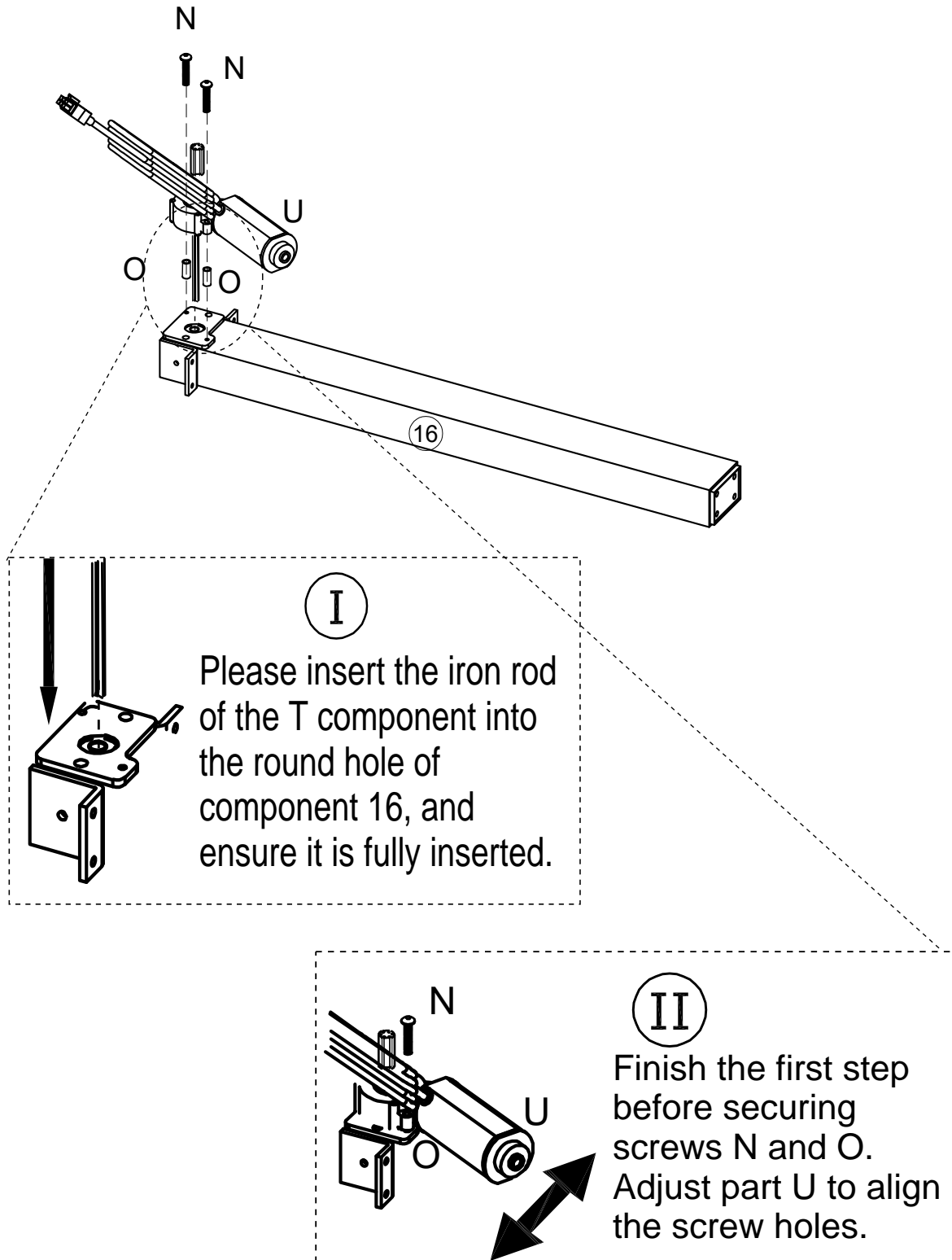
P x 1  2 mm	N x 2 	O x 2 
--	--	--



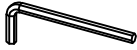

# Step 14

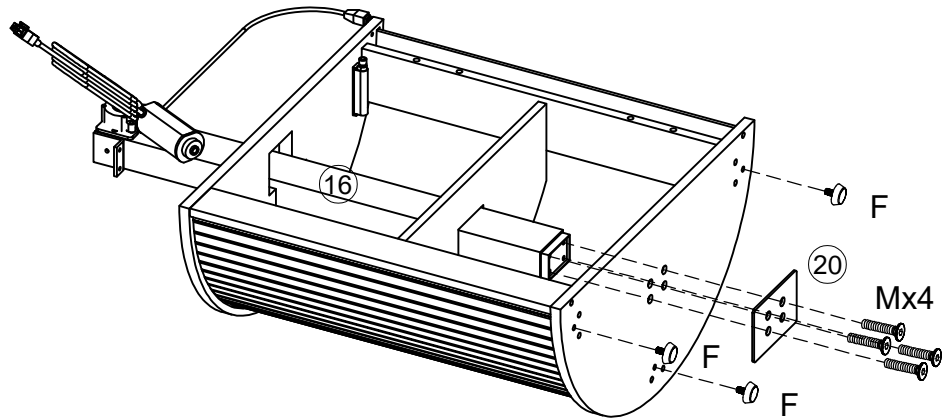
M x 4  M6x35 mm	R x 1  4 mm	F x 3 
---	--	--



# Step 15

V x 4 	D x 8  Ø3.5x14 mm
--	--

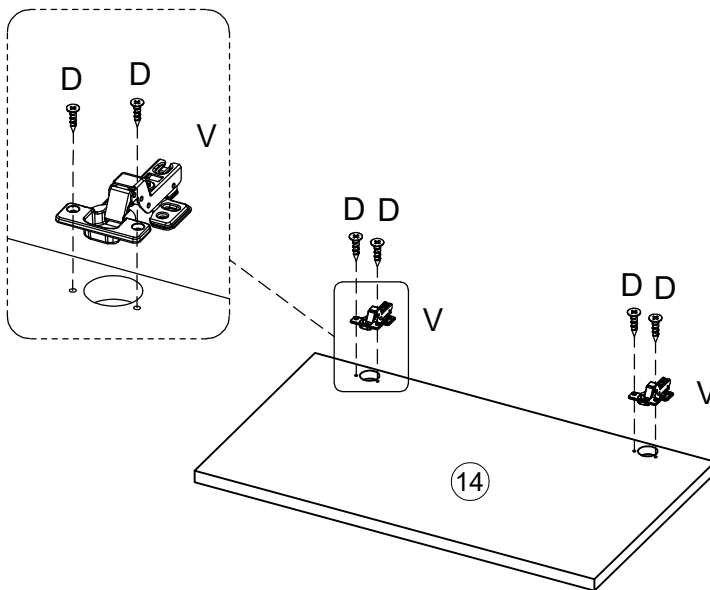

× 2

# Step 16

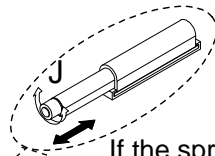

If the spring-loaded door cannot be opened by pressing, you can rotate the head of component J to adjust its length.

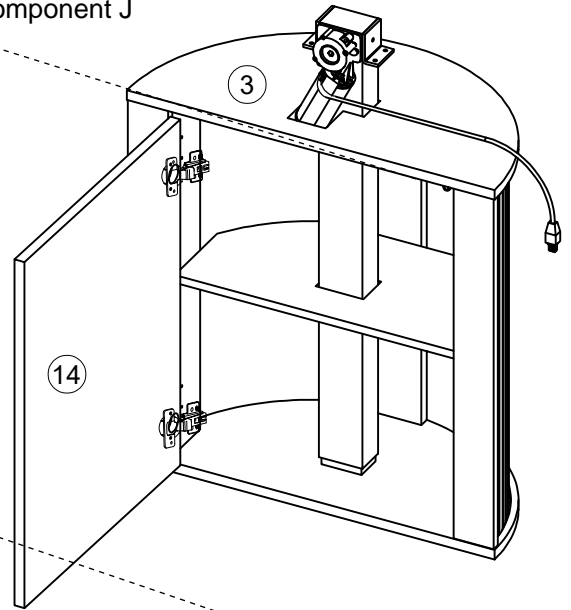
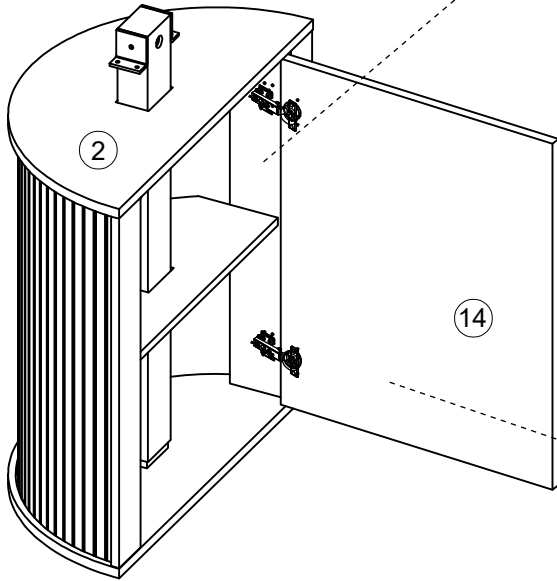
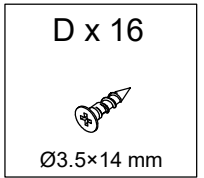

If you find that the screw holes do not align when installing, you can adjust the A screw and align the holes before installing.

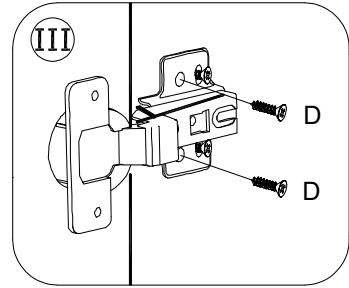
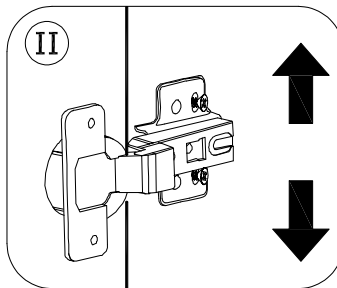
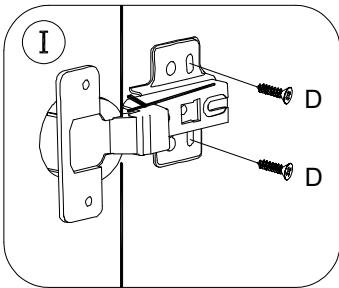
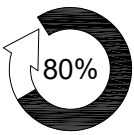
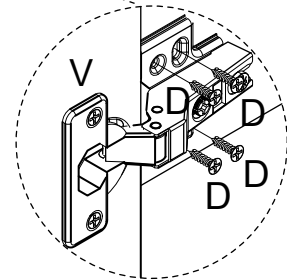
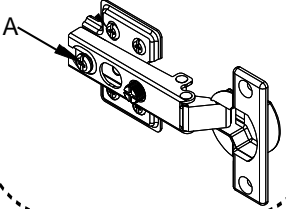

## How do I get the two doors to align flat by adjusting the hinges?



**01** Adjust the screws shown in Figure 1 to adjust the doors up and down.



**02** Adjust the screws shown in Fig. 2 and pull the door back and forth so that it can be opened smoothly.



**03** Adjust the screws shown in Figure 3 to adjust the door left and right to the right position.



**04** After the adjustment is complete, install the remaining two screws to secure the door in place.

# Step 17

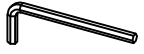

L x 12  M6x16 mm	R x 1  4 mm
---	--

**Please note:** When assembling this step, be careful not to let the assembled Step 12 loosen. Keep the tabs snapped into place.

III

Align one end of the iron rod of Part No. 19 with the round hole shown in the diagram and insert it all the way to the bottom.

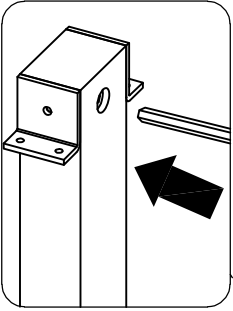

The other side should also be secured with 2 L screws from the bottom upwards

I

Loosen the plastic fitting as shown in the illustration, and then extend the iron rod to an appropriate length.

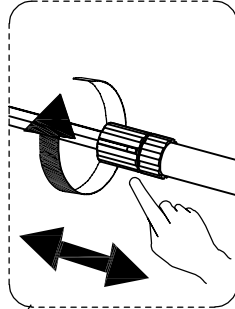

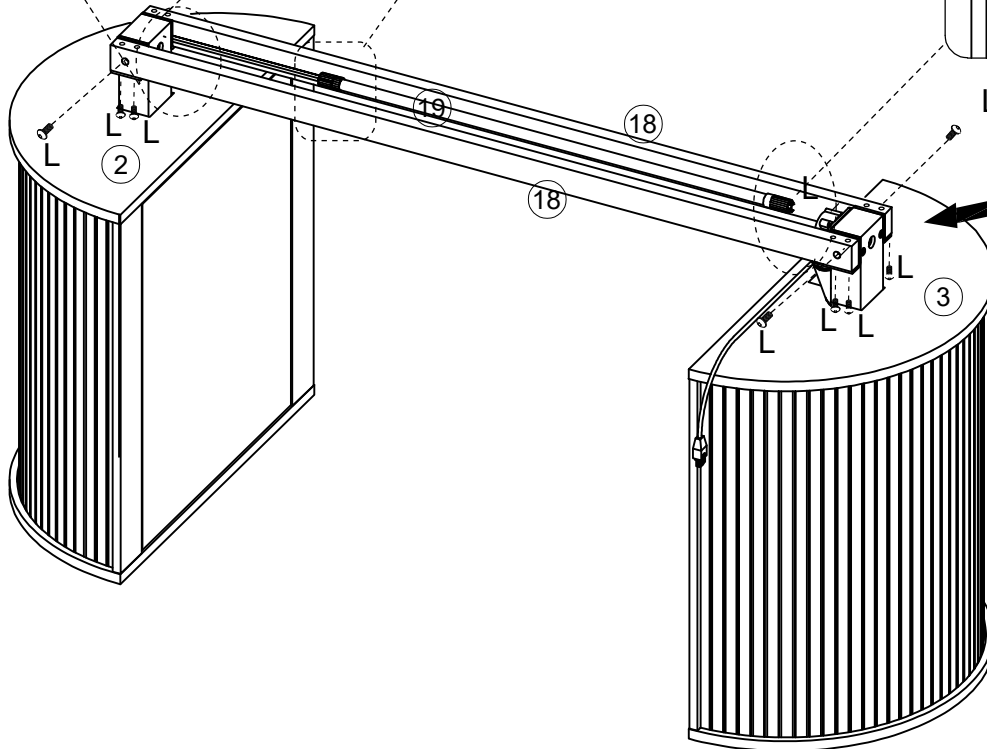
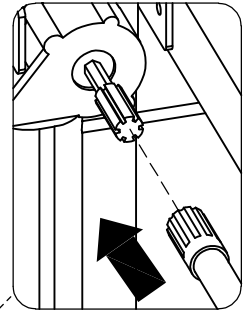

II

Align the plastic end of Component 19 with the plastic connector on the other side, then press it into place.



The other side should also be secured with 2 L screws from the bottom upwards

# Step 18

I x 4  M5x15 mm	Q x 1  3 mm
--	--

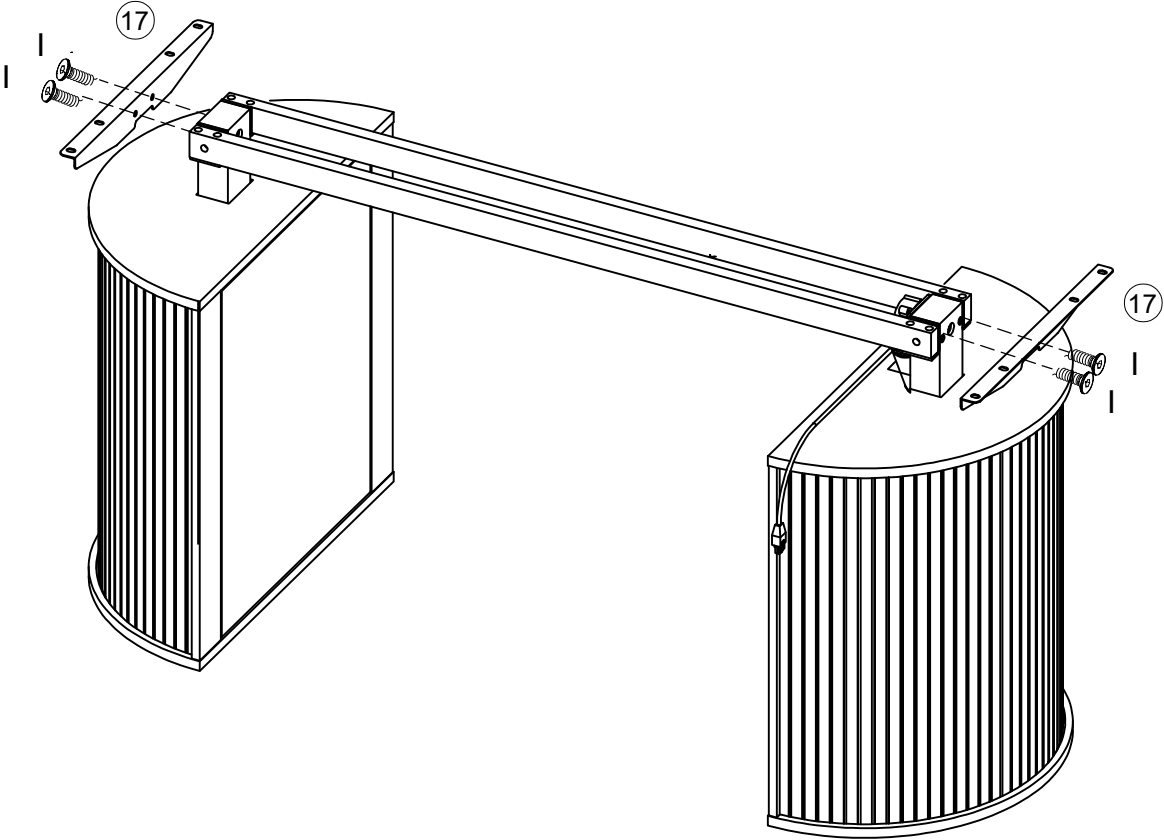

# Step 19

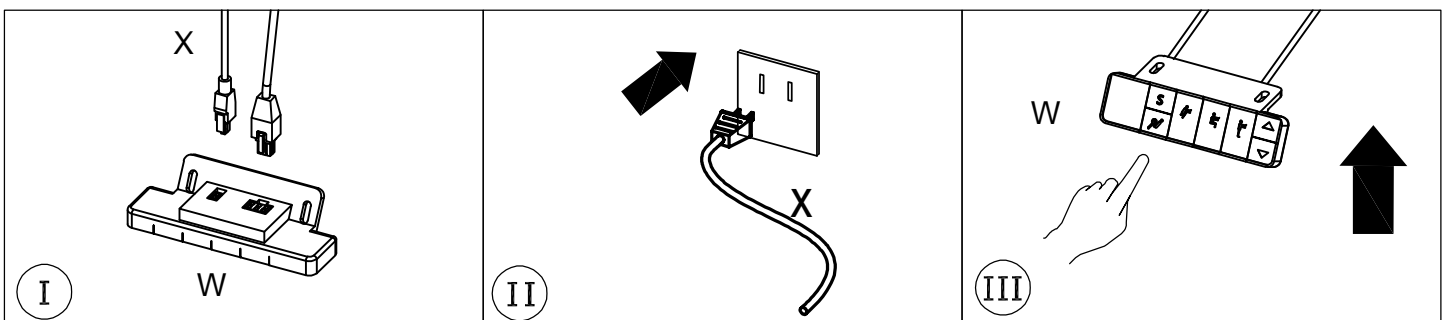
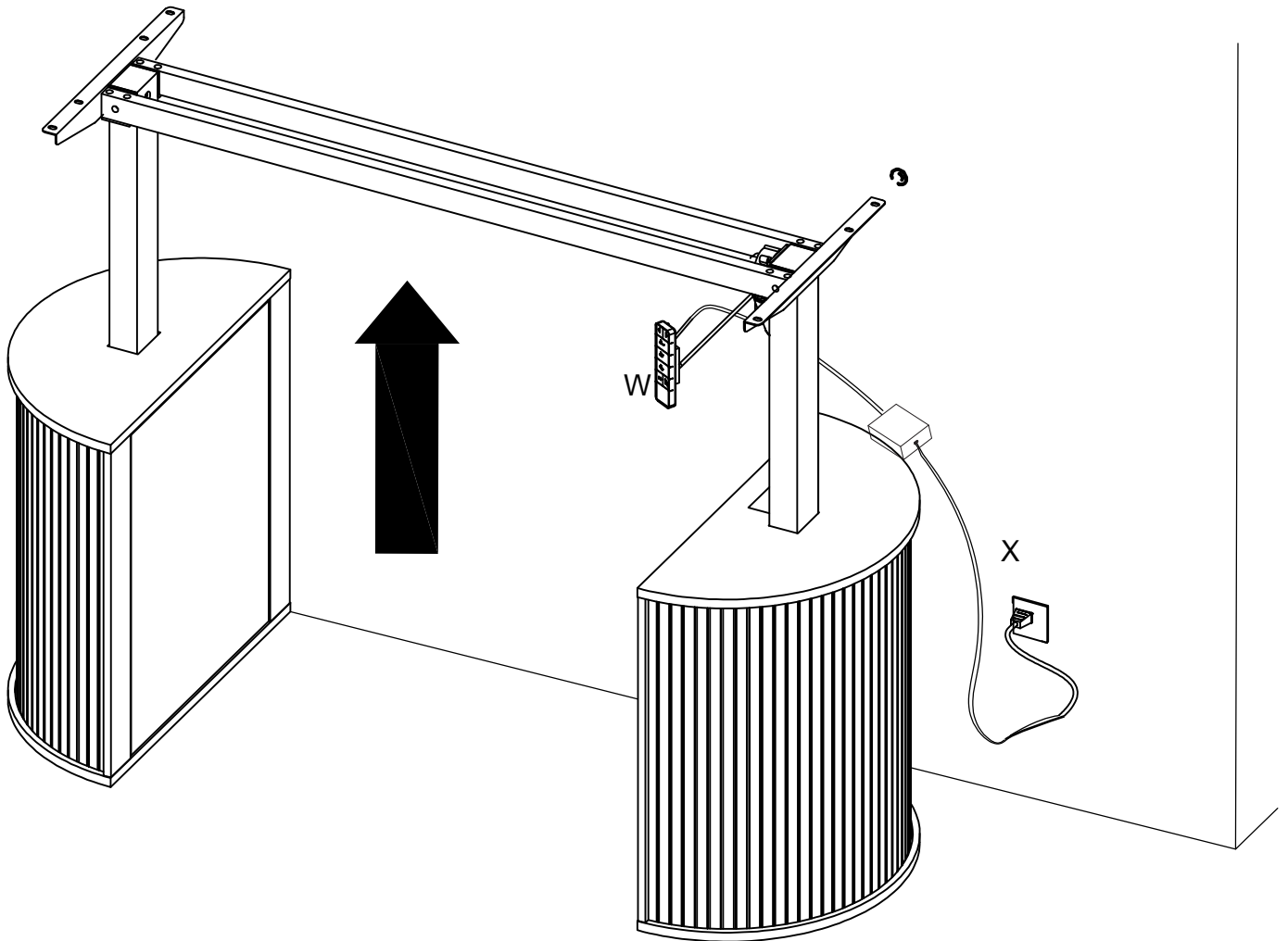
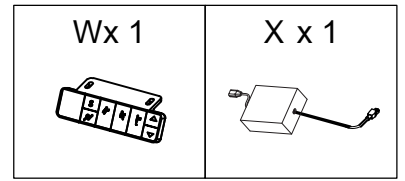

# Step 20



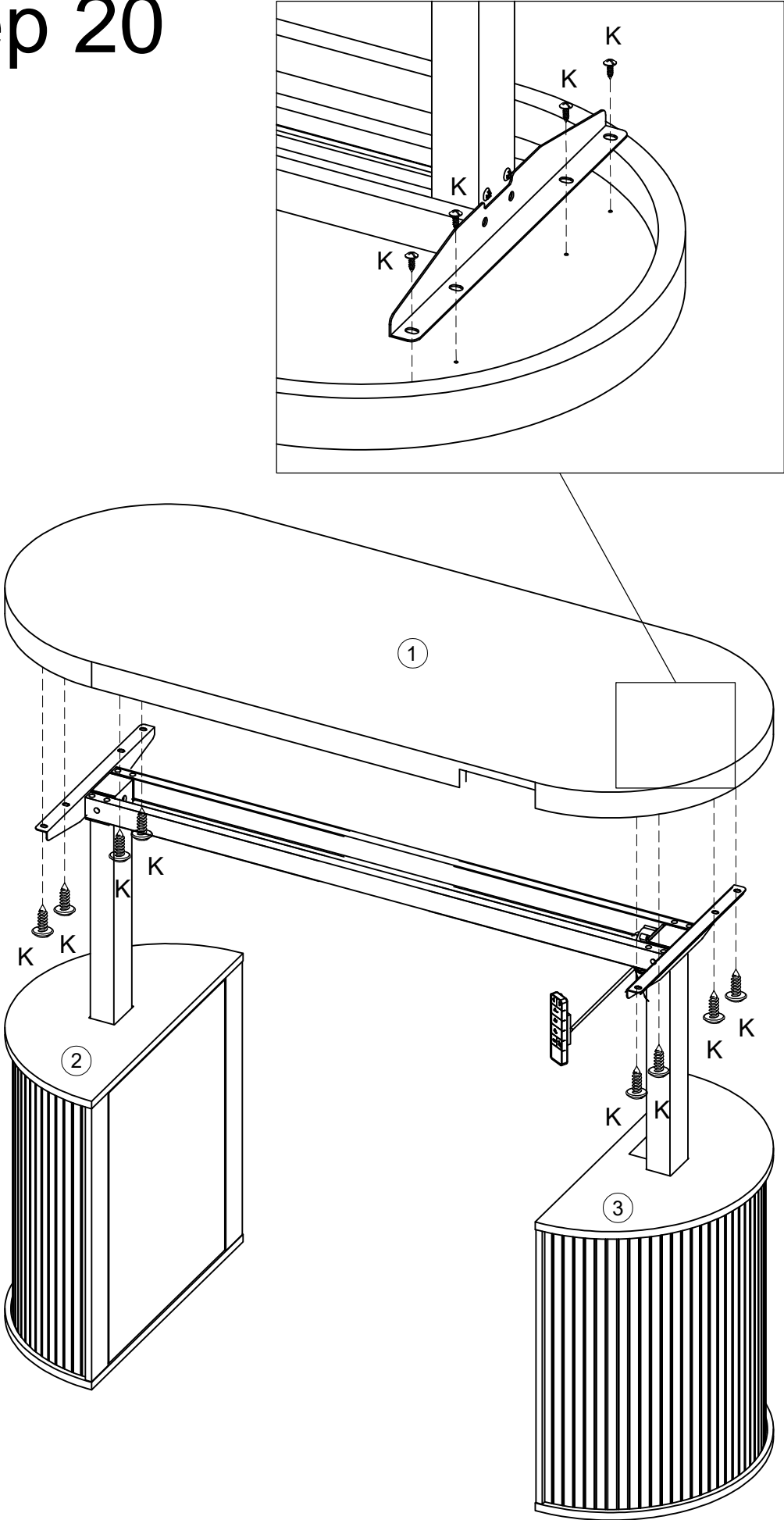

K x 8  
  
Φ5×14 mm

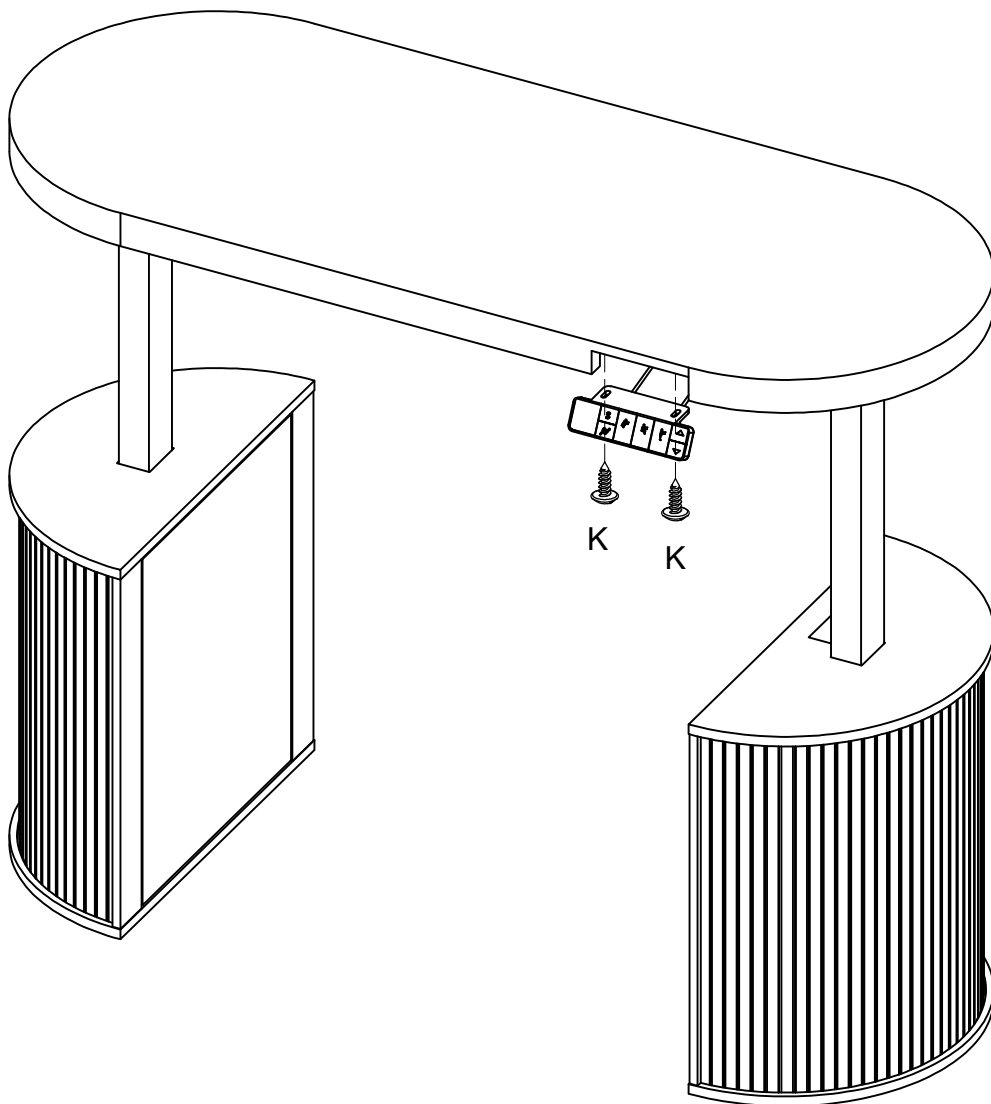
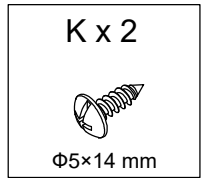

# Step 21



# Step 22

K x 2  Φ5×14 mm	H x 2 	S x 2 	E x 2  Ø4×35 mm
--	---	--	--

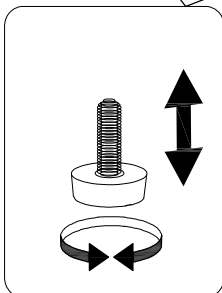
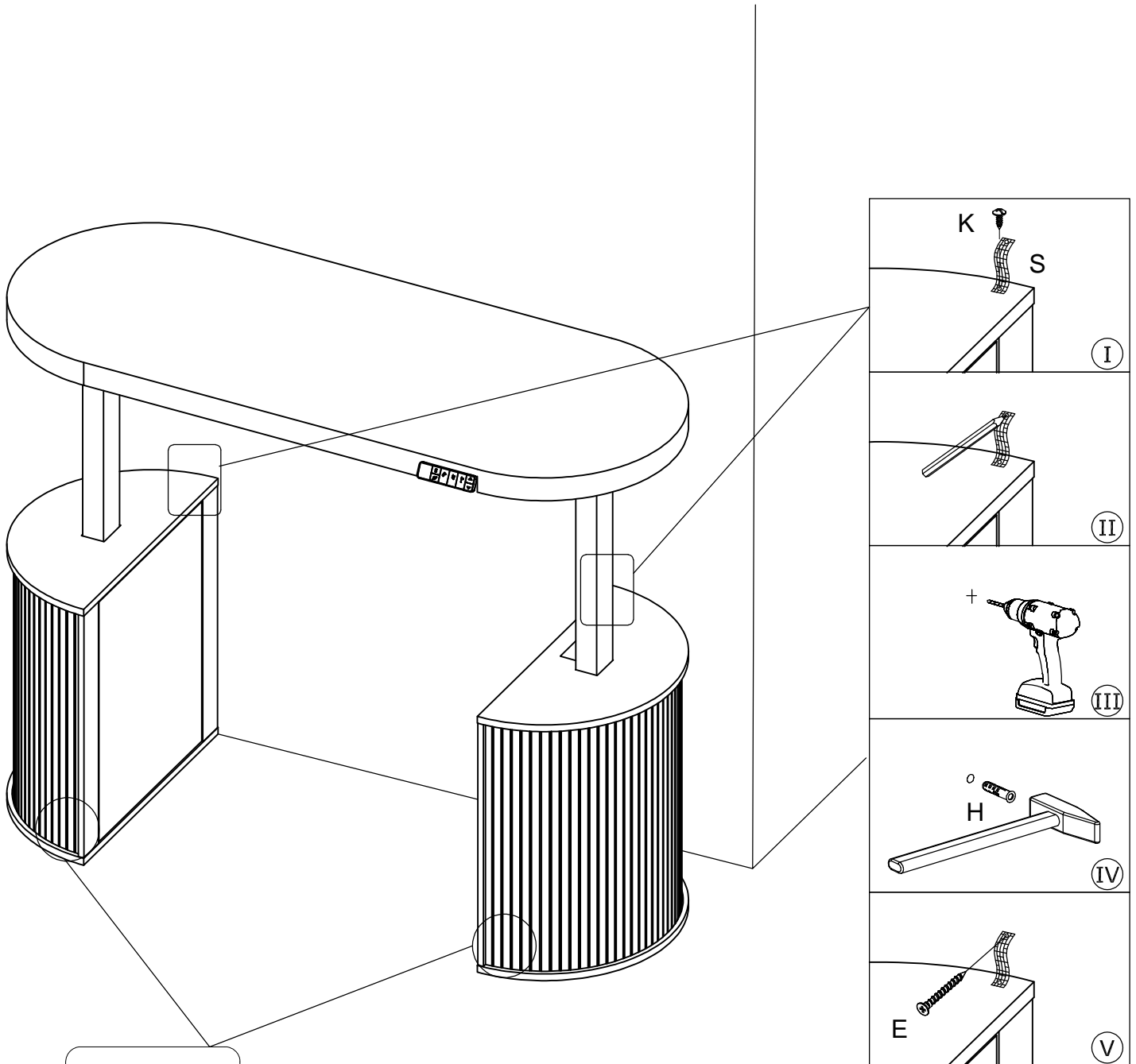

If the center position of the cabinet is too high or too low due to uneven bottom plates or other reasons, adjust the adjustable foot pads on feet F to adjust the upper and lower height

# Step 23

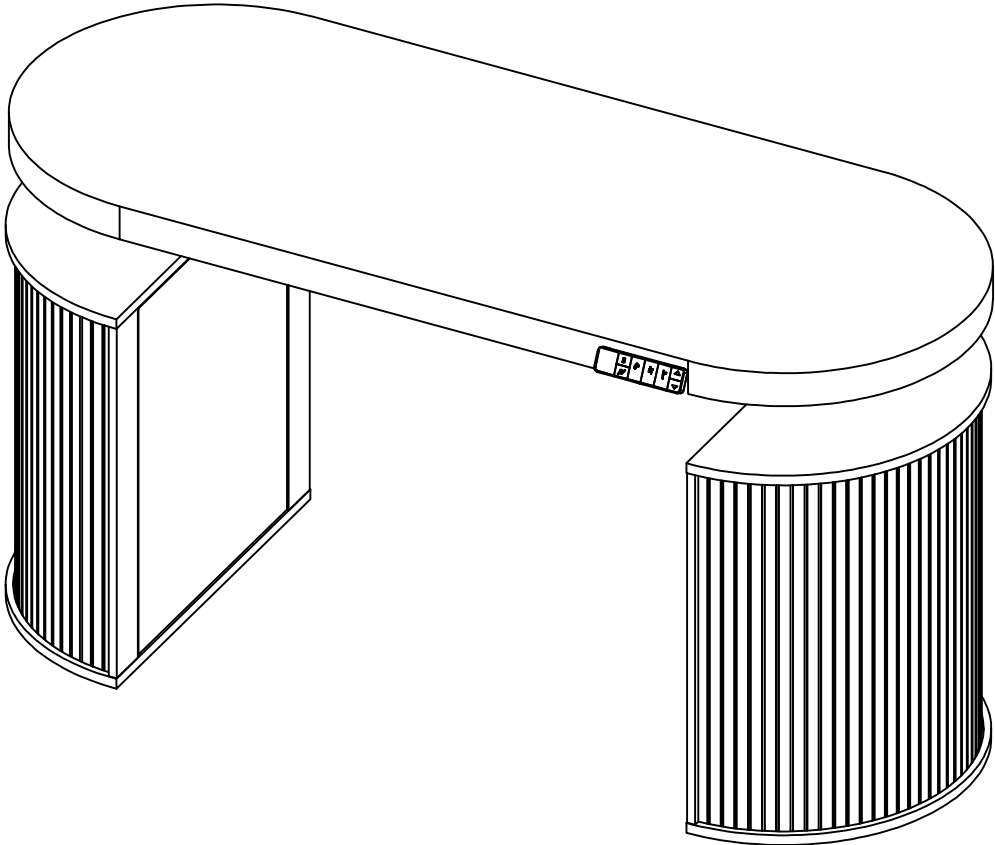
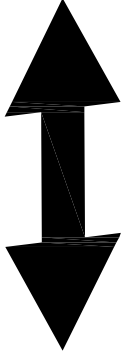
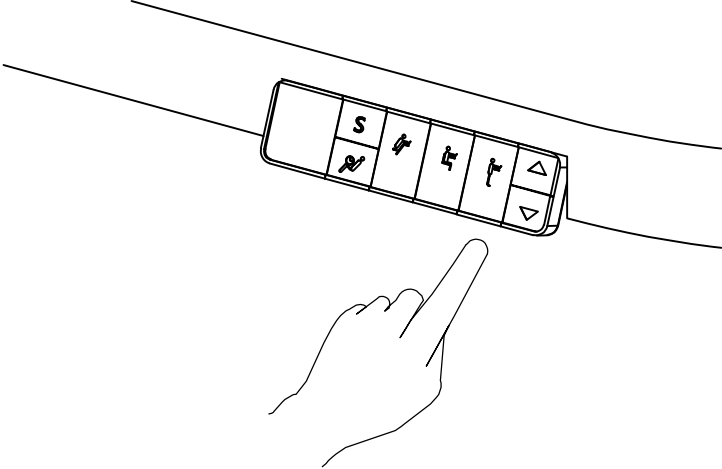

# Product Operation Instructions

## (1) Initial Power-On

After the hand controller is powered on, it displays the current height.

If the height value displayed by the hand controller does not match the actual height of the lifting column, or if the height of the lifting column has changed after reassembly, a reset operation is required. Otherwise, it can be used directly according to the factory default settings.

## (2) Reset Operation

Press and hold the "▼" key until the lifting column stops. Continue to hold the "▼" key for 5 seconds. At this time, the hand controller displays "rES", and the reset starts. The lifting column slowly descends to the lowest end. After all the lifting columns reach the lowest end and rebound 0.5cm, the reset operation is complete.

(If the key is released during the reset process, the reset process will not be interrupted.)

## (3) Upward Movement Operation

Press and hold the "▲" key on the hand controller to raise the desk. Release the key to stop.

## (4) Downward Movement Operation

Press and hold the "▼" key on the hand controller to lower the desk. Release the key to stop.

## (5) Memory Position Operation



Memorize the current height into the program internally; memory will be retained after power failure.

## Memory Preset and Display:

Short press the **S key** to display the current height and blink (for 3 seconds or press the **S key** again to exit). While blinking, short press any key 1-3 to set the memory preset. After successful setting, H1/H2/H3 will be displayed for 2 seconds before exiting.

When the memory preset key is pressed, the "target position height" is displayed first for 1 second, and then it runs with the real-time display value of the desk frame height until it runs to the target position and stops (press any key or any combination of keys to stop running).

## Memory Preset Requirements:

Three-memory controller:  preset corresponds to the lowest height,  preset is 860 height,  preset is the highest height.

## (6) Height Display

The default is Imperial display; Metric mode does not display decimal points, 72cm is displayed as 072; Imperial displays decimal points.

## (7) Wake-up Function

No wake-up function: When the hand controller is in screen-off state, short press 1-3 preset keys to light up the screen and start running immediately, without a second key press.

## (8) Child Lock

Simultaneously press and hold the "**▲**" and "**▼**" keys for 3 seconds. When the hand controller displays "LoC", it indicates that the system is locked and no lifting operations can be performed on the system; in the locked state, simultaneously press and hold the "**▲**" and "**▼**" keys for 3 seconds.

When the hand controller display changes from "LoC" to a normal number display, it indicates that the system is unlocked.

### **(9) Energy Saving Mode**

If there is no key operation within 30 seconds, it will enter the energy-saving mode. At this time, the hand controller display is turned off, and the controller enters low power consumption. Pressing any key can exit the energy-saving mode. Short press the **S** key to display "current height" and blink.

### **(10 Automatic Test (Needs to be enabled by the host computer, default is off)**

1. Entry Method: Simultaneously press and hold the "**▲**" + "**▼**" + "**S**" keys for 2 seconds. At this time, all decimal points of the digital tube are displayed, indicating the automatic test mode. To exit the automatic mode, simultaneously press and hold the "**▲**" + "**▼**" + "**S**" keys for 2 seconds.
2. Support the system to run "up and down lifting" for one cycle and stop for 4 minutes for automatic testing. The test stroke is from the position stored in "1" to the position stored in "3". In the automatic test mode, the system will run back and forth between "1" and "3" for one cycle, and then stop for 4 minutes, and repeat infinitely.
3. During the automatic test run, the height is displayed. After the run is completed, the count is displayed.

### **(11) Function Menu Description**

Metric/Imperial Conversion:

1. Long press the **S** key for 3 seconds: "S—" is displayed and blinks, entering the main menu. Unless otherwise required, only Un and CF functions are available by default. Short press "**▲**" and "**▼**" to switch between Un and CF function options.

2.Short press the “**S**” **key** to select the Un menu page. After entering, the previously set height unit value is displayed. Then short press “▲” and “▼” keys to toggle the options under the Un function (SI, In). Short press the S1 key to return to the previous level menu.

3.After selecting, short press the **S key** to save the current selected option value and exit the settings interface.

4.If no key is pressed within 20 seconds, the settings interface will be exited.

### **(12) Sedentary Reminder**

Press the controller  key. The controller displays x.xh (0.0h-4.0h). At this time, press up or down to adjust the timing, each key press changes by 0.5h.

### **(13)Error Codes**

Code	Interpretation	Handling Method
E31	Main power voltage abnormal (voltage below 20V)	Replace main power supply
E32	Main power voltage abnormal (voltage above 36V)	Replace main power supply
E02	Obstacle rebound (reverse running 4CM, considering the consistency of the columns, temporarily removed)	Remove obstacle
Hot	Continuous operation within 5 minutes, stop interval less than 10 seconds	Wait 15 minutes to exit Hot or power cycle
E10	Motor wire not connected	Check the connecting wires
E20	Too much load / stalled / reached the top	Reduce load / reset