









# ASSEMBLY INSTRUCTION

CVFNR4637

PARTS LIST			HARDWARE LIST			
S.NO.	DESCRIPTION	QTY	S.NO.	DESCRIPTION	QTY	
A	 TOP	1	I	 ALLEN BOLT	8	
			II	 WASHER	8	
B	B1	 LEGS	1	III	 SPRING WASHER	8
	B2	 LEGS	1	IV	 ALLEN KEY	1
			V	 METAL L CLIP	2	

**STEP 1.** Put the Top on clean surface on upward down, place the Leg as shown as image.

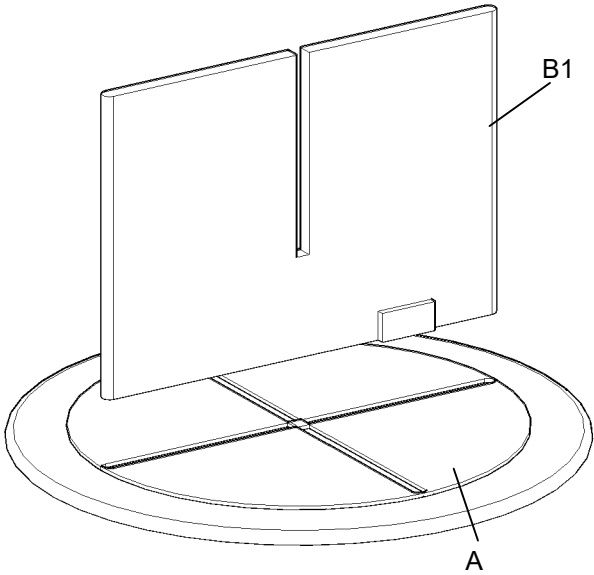

**STEP 2.** Now place the other Leg as shown as image.

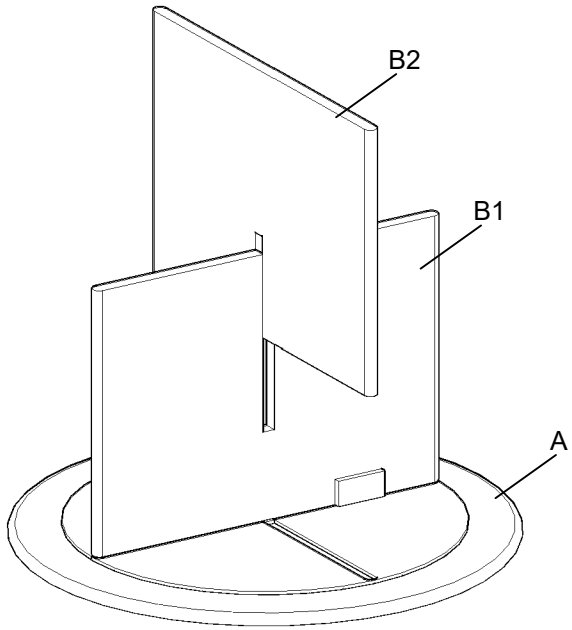

**STEP 3.** Now tighten the Bolt with help of hardware. Once Legs get tighten, upright the Table.

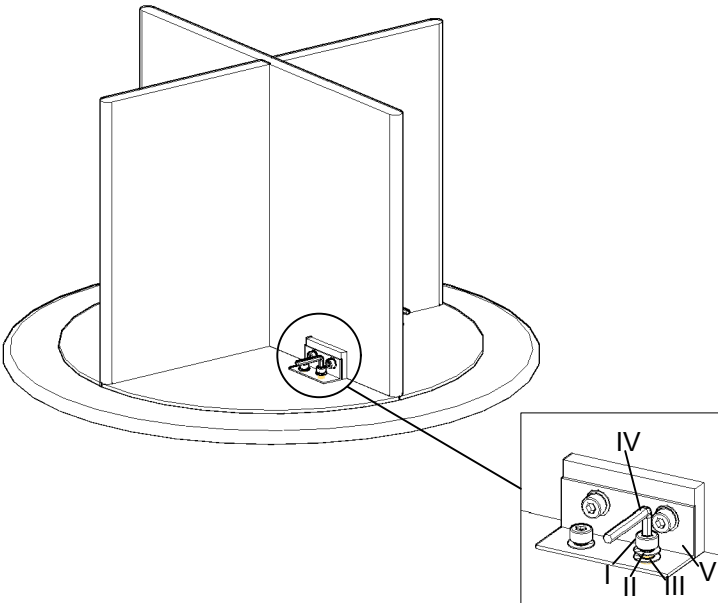

**STEP 4.** Assembly Complete.

