

615085

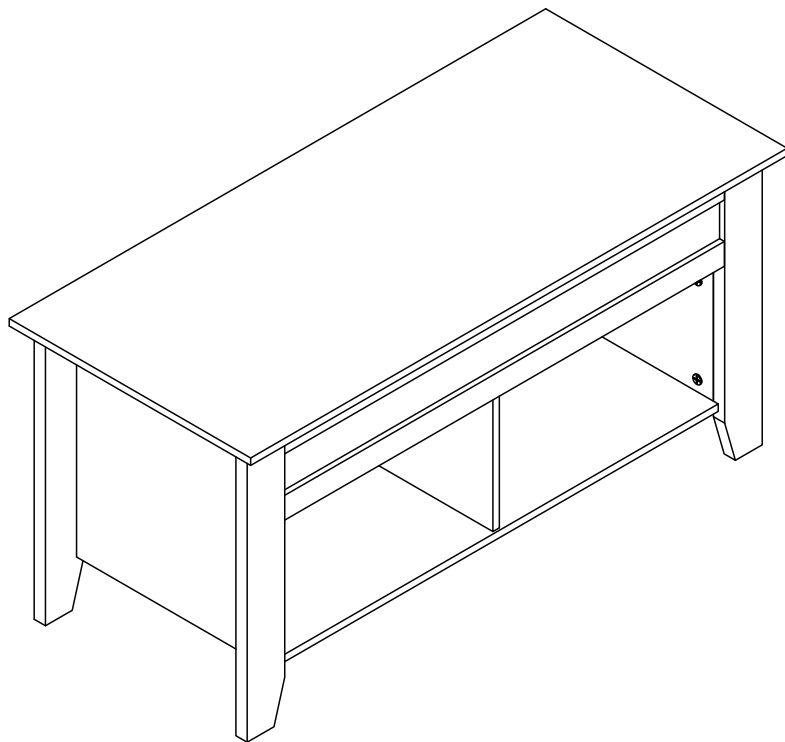

- EN** - Please read this instruction manual carefully before attempting to install.
DE - Bitte lesen Sie diese Bedienungsanleitung vor der Montage gründlich durch.
ES - Por favor lea con atención el manual de instrucciones antes de llevar a cabo el ensamble.
FR - Lisez attentivement cette notice avant de commencer le montage.
IT - Si prega di consultare il libretto delle istruzioni prima del montaggio.

IMPORTANT/WICHTIG/ATENCIÓN

IMPORTANT/IMPORTANTE



EN - We recommend **2** or more people to install.
DE - Wir empfehlen, dass die Montage von **2** oder mehreren Personen durchgeführt werden sollte.
ES - Recomendamos realizar el ensamble con **2** o más personas.
FR - Il est recommandé d'effectuer le montage à **2** personne(s) ou plus.
IT - È necessaria la presenza di **2** o più persone per il montaggio di questo prodotto.



EN - The expected assembly time is **1 h**.
DE - Die Montagezeit beträgt durchschnittlich **1 h**.
ES - El tiempo aproximado de ensamble es de **1 h**.
FR - Le temps nécessaire est estimé à **1 h**.
IT - Il tempo previsto per il corretto assemblaggio è di **1 h**.



EN - Not intended for use by children.
DE - Nicht geeignet für Kinder.
ES - Producto no apto para niños.
FR - Produit non destiné à être utilisé par des enfants.
IT - Questo prodotto non è destinato all'uso da parte dei bambini.











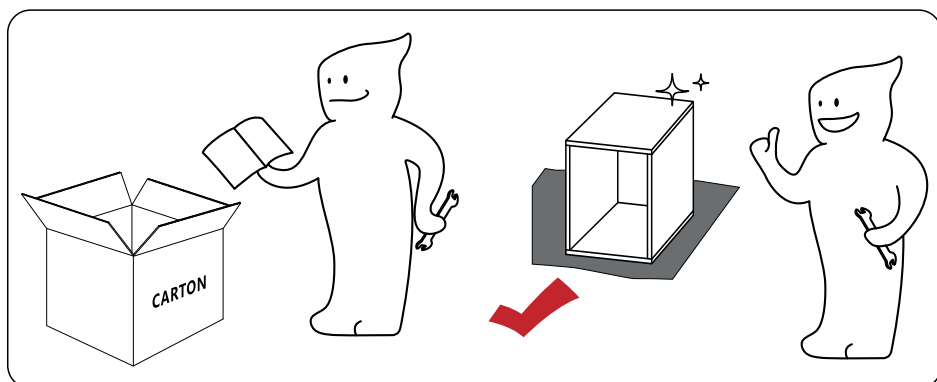
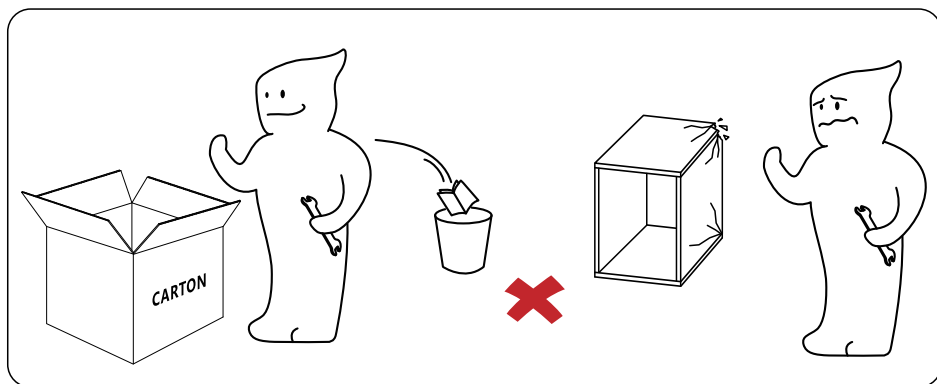

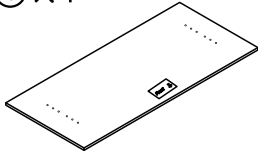
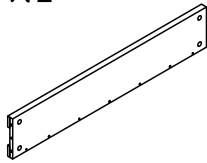
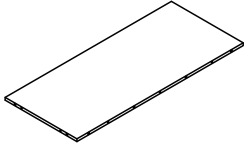
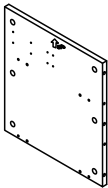
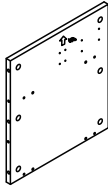
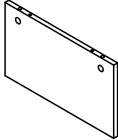
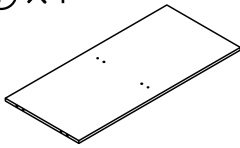
EN - Keep away from fire or other heat sources.
DE - Bitte von Feuer und Hitzequellen fernhalten.
ES - Manténgase alejado de las llamas y otras fuentes de calor.
FR - Tenir à distance des flammes et autres sources de chaleur.
IT - Tenere lontano dal fuoco o da altre fonti di calore.

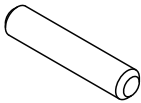
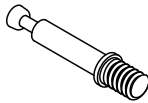

EN - We recommend wearing protective gloves.
DE - Wir empfehlen das Tragen von Schutzhandschuhen.
ES - Recomendamos el uso de guantes de seguridad.
FR - Il est recommandé de porter des gants de protection.
IT - Per il processo di assemblaggio, consigliamo fortemente l'utilizzo di guanti protettivi.

- EN** - Please follow the instruction manuals and use a pad to avoid damage during assembly.
- DE** - Bitte folgen Sie der Anleitung und verwenden Sie eine Unterlage, um Beschädigungen bei der Montage zu vermeiden.
- ES** - Por favor, siga las instrucciones del manual y utilice una cubierta o lona para proteger el producto y el suelo durante la instalación.
- FR** - Suivez les instructions de la notice et utilisez une couverture ou une bâche pour protéger le produit et les sols pendant le montage.
- IT** - Si prega di consultare il manuale illustrativo durante il montaggio e di utilizzare un cuscinetto per evitare possibili danni.

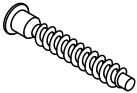
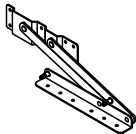
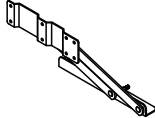
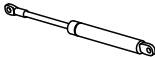

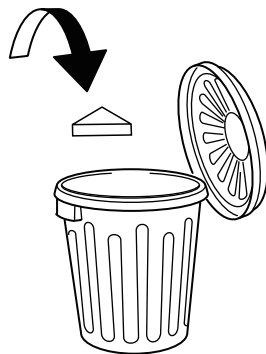
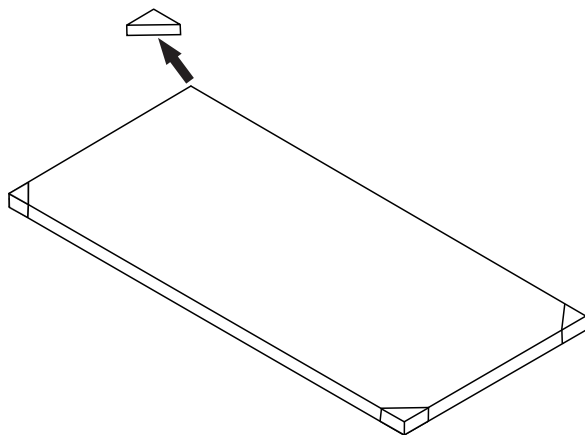

<p>① × 1</p> 	<p>② × 2</p> 	<p>③ × 1</p> 		
<p>④ × 1 R</p> 	<p>⑤ × 1 L</p> 	<p>⑥ × 1</p> 		
<p>⑦ × 1</p> 	<p>⑧ × 2</p> 	<p>⑨ × 2</p> 		
<p>Ⓐ × 4</p> 	<p>Ⓑ × 30</p> 	<p>Ⓒ × 38</p> 	<p>Ⓓ × 38</p> 	
<p>Ⓔ × 1</p> 	<p>Ⓕ × 1</p> 	<p>Ⓖ × 28</p> 	<p>Ⓗ × 2</p> 	
<p>Ⓘ × 1 L</p> 	<p>Ⓙ × 1 R</p> 	<p>Ⓚ × 2</p> 	<p>Ⓛ × 4</p> 	<p>Ⓜ × 4</p> 

- EN** - Please remove the protective caps on the board ends before assembling. Protective caps are not a part of this product, they're designed to protect the product during transportation.
- DE** - Bitte entfernen Sie vor der Montage die Schutzkappen auf dem Brett. Schutzkappen sind nicht Bestandteil dieses Produkts, sie sollen das Produkt während des Transports schützen.
- ES** - Retire la tapa protectora de las esquinas de la tabla antes del montaje. Las tapas protectoras no forman parte de este producto, están diseñadas para proteger el producto durante su transportación.
- FR** - Retirer le capuchon de protection de l'extrémité de la plaque avant l'assemblage. Les capuchons de protection ne font pas partie de ce produit, ils sont conçus pour protéger le produit pendant le transport.
- IT** - Si prega di rimuovere i tappi di protezione sulle estremità dell'asse prima dell'assemblaggio. i tappi di protezione non rappresentano parte del prodotto, sono designati per garantire protezione durante il trasporto.

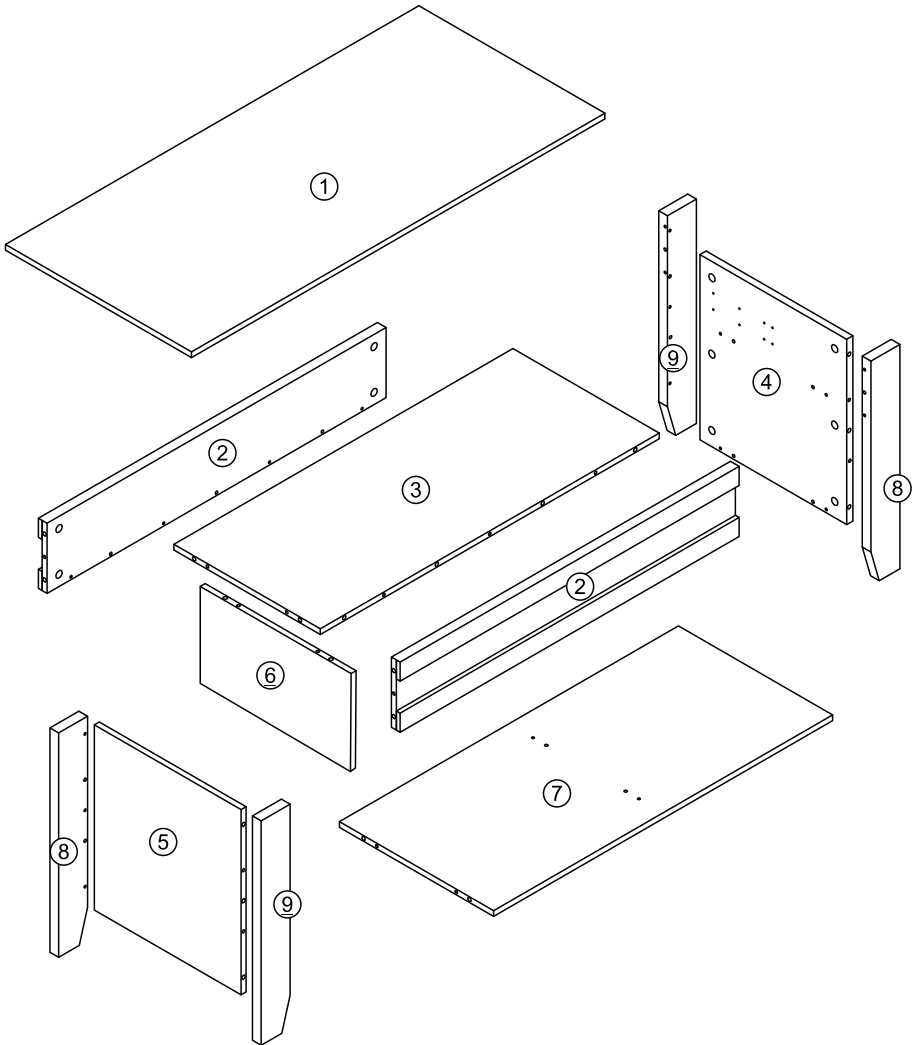



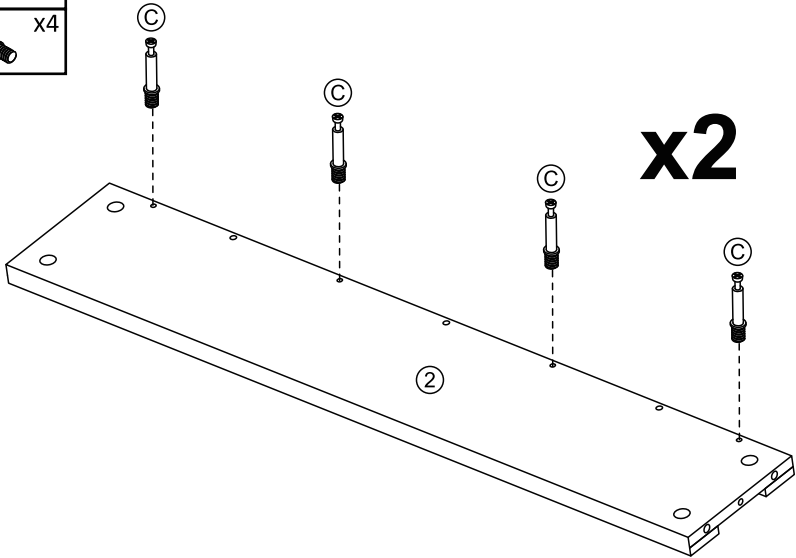

1

②		x1
Ⓒ		x4



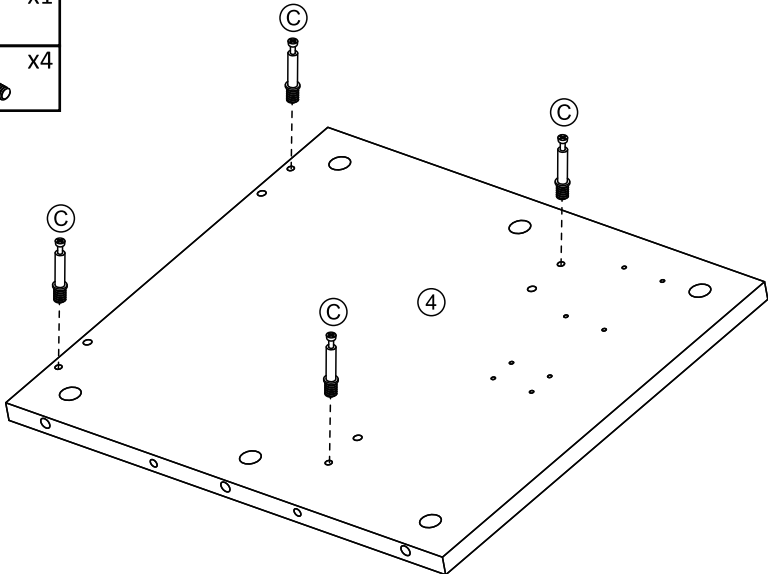

2

④		x1
Ⓒ		x4



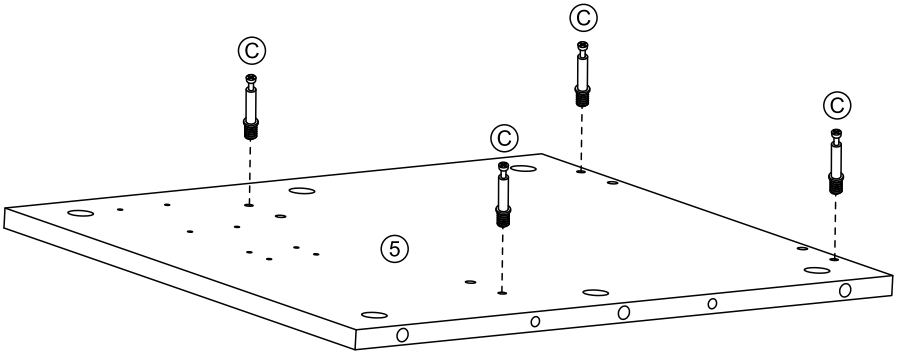
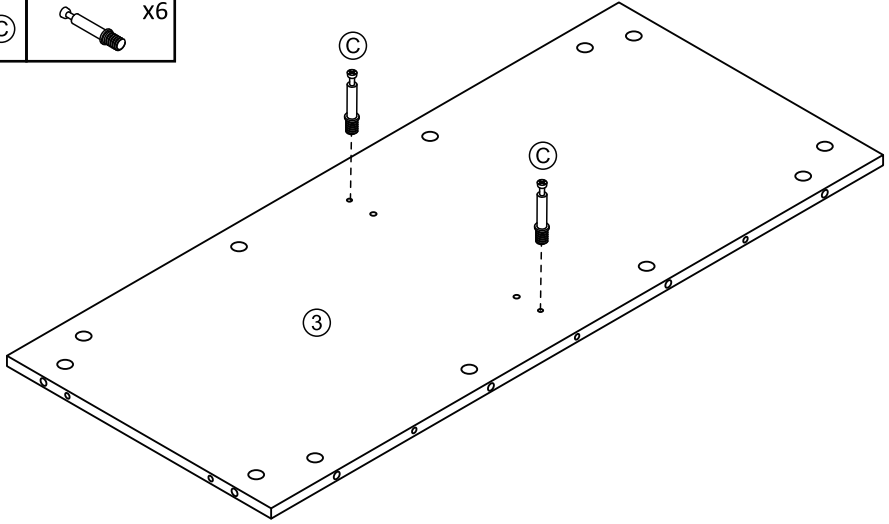

3

③		x1
⑤		x1
Ⓒ		x6



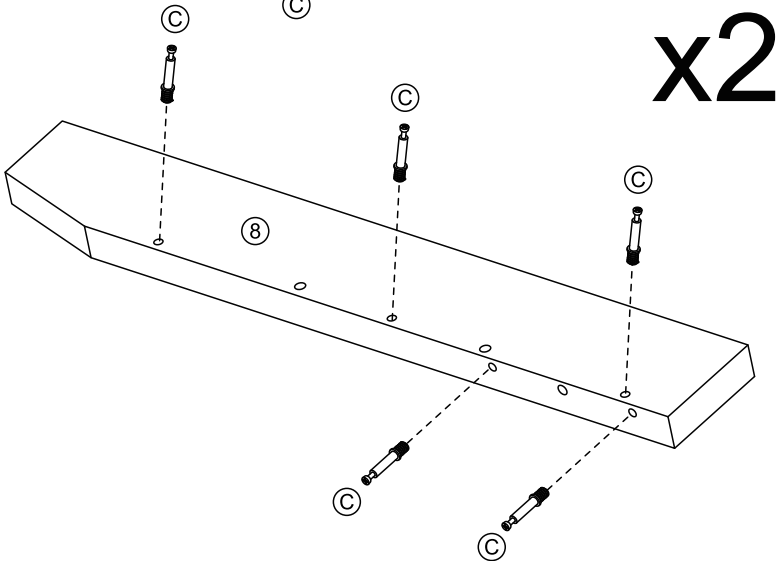
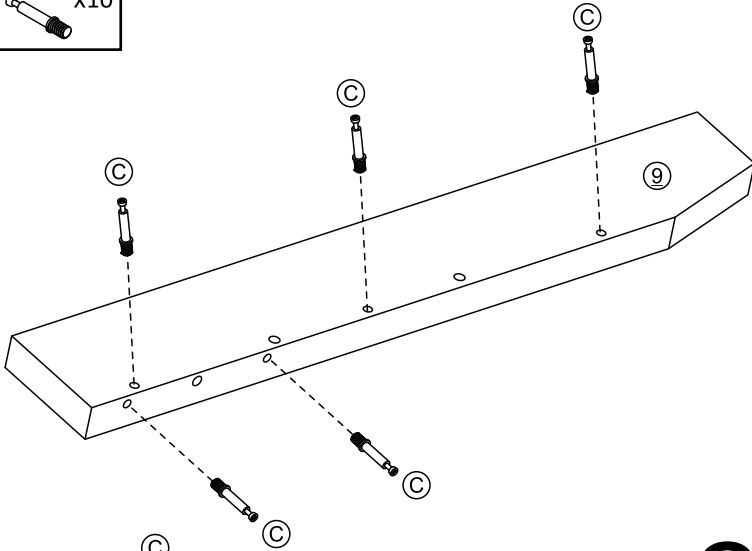

4

⑧		x1
⑨		x1
Ⓒ		x10



5

(B)		x8
(D)		x12

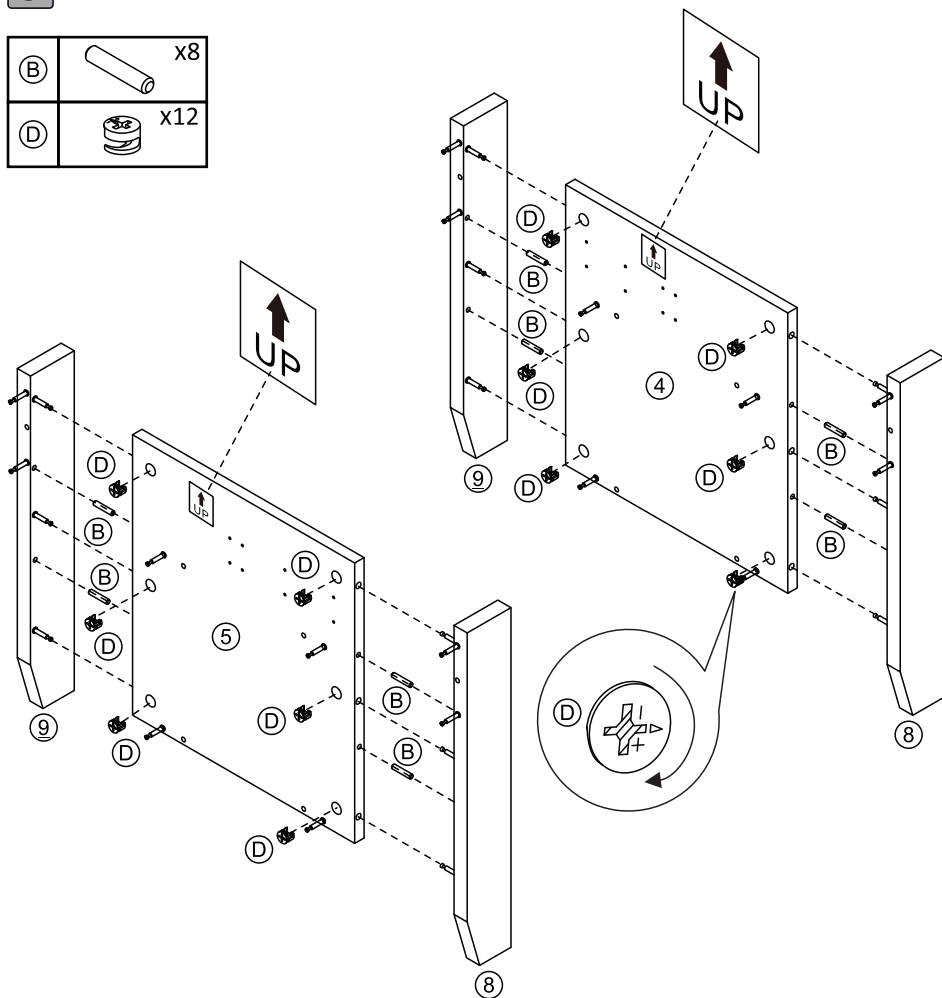

EN - When installing panel (4) and (5), please make sure the top side has more holes than the bottom.



DE - Achten Sie bei der Montage von Platte (4) und (5) darauf, dass die Oberseite mehr Löcher als die Unterseite hat.

ES - Al instalar los paneles (4) y (5), asegúrese de que el lado superior tenga más agujeros que el inferior.

FR - Pour le montage des panneaux (4) et (5), veillez à placer la partie avec le plus de trous vers le haut.



IT - Durante il montaggio dei pannelli (4) e (5), assicurarsi che la parte superiore presenti più fessure rispetto alla parte inferiore.

6

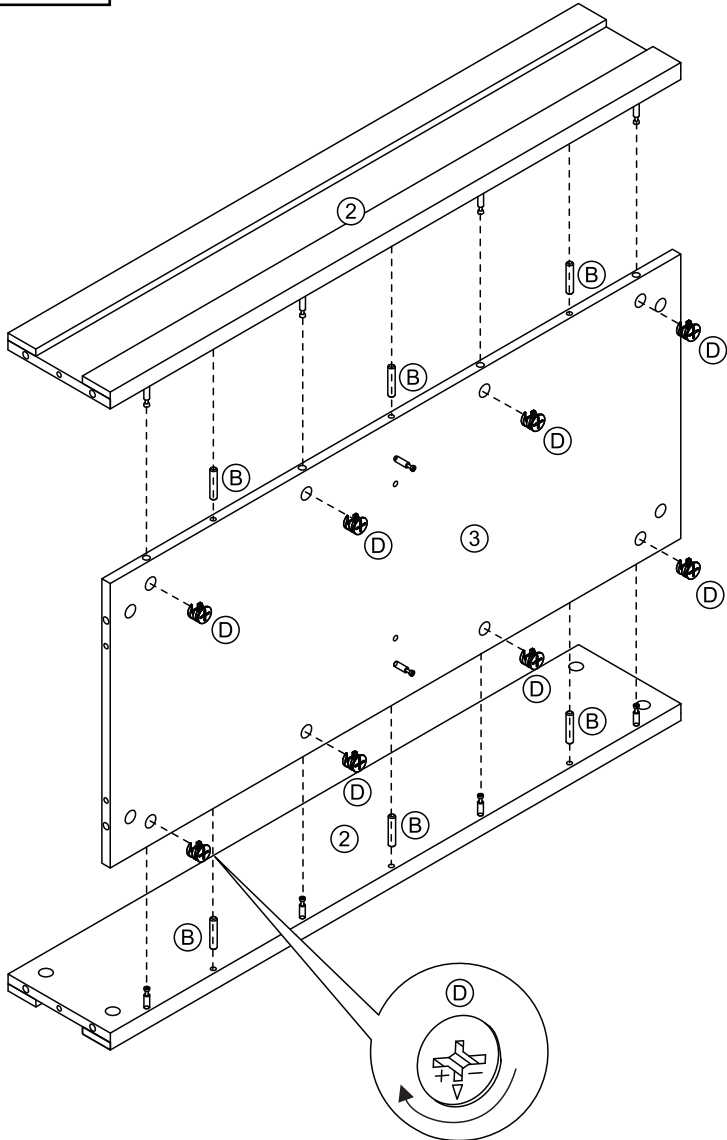
(B)		x6
(D)		x8



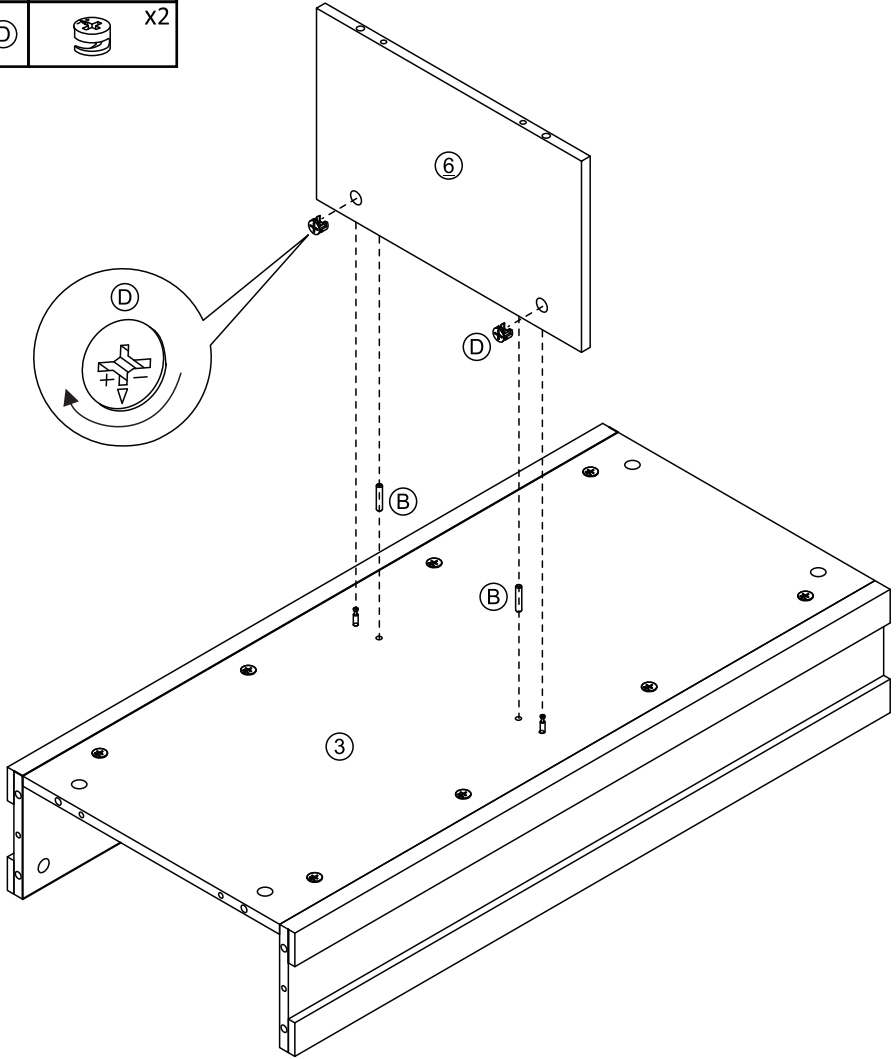

7

⑥		x1
Ⓑ		x2
Ⓓ		x2



8

⑦		x1
Ⓑ		x2
Ⓜ		x2

EN - Note: No.7 panel shall be kept balanced during assembly. The over tilt may cause component damage.

DE - Hinweis: Die Platte Nr. 7 sollte während der Montage im Gleichgewicht gehalten werden, da eine starke Neigung Schäden an den Bauteilen verursachen kann.



ES - Nota: El tablero n° 7 debe mantenerse equilibrado durante el montaje. La inclinación excesiva puede causar daños en los componentes.

FR - Remarque : Le panneau n° 7 doit être maintenu en équilibre pendant l'assemblage, car une grand inclinaison peut endommager les composants.

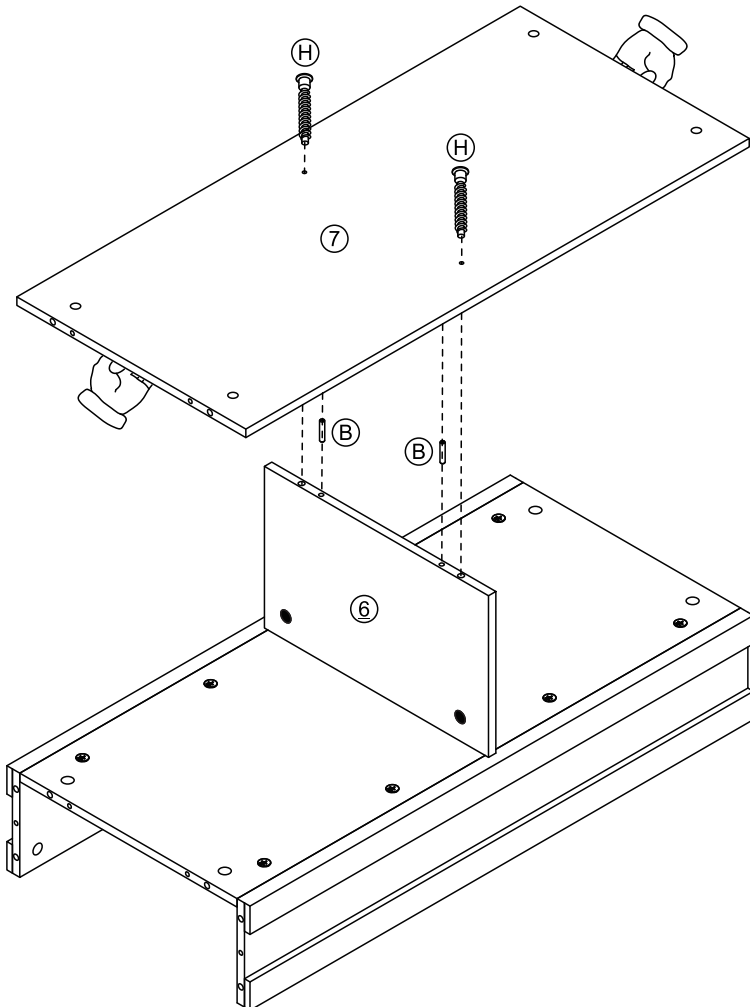
IT - Nota: Il pannello n. 7 deve essere mantenuto in equilibrio durante l'assemblaggio. Un'inclinazione eccessiva potrebbe causare danni ai componenti.



9

(B)		x12
(D)		x8
(L)		x4

EN - Note: No.7 panel shall be kept balanced during assembly. The over tilt may cause component damage.

DE - Hinweis: Die Platte Nr. 7 sollte während der Montage im Gleichgewicht gehalten werden, da eine starke Neigung Schäden an den Bauteilen verursachen kann.

ES - Nota: El tablero n° 7 debe mantenerse equilibrado durante el montaje. La inclinación excesiva puede causar daños en los componentes.

FR - Remarque : Le panneau n° 7 doit être maintenu en équilibre pendant l'assemblage, car une grand inclinaison peut endommager les composants.

IT - Nota: Il pannello n. 7 deve essere mantenuto in equilibrio durante l'assemblaggio. Un'inclinazione eccessiva potrebbe causare danni ai componenti.



EN - Assembly requires 2 adults.

DE - Die Montage erfordert 2 Erwachsene.



ES - Para el montaje se necesitan 2 adultos.

FR - L'assemblage nécessite 2 adultes.

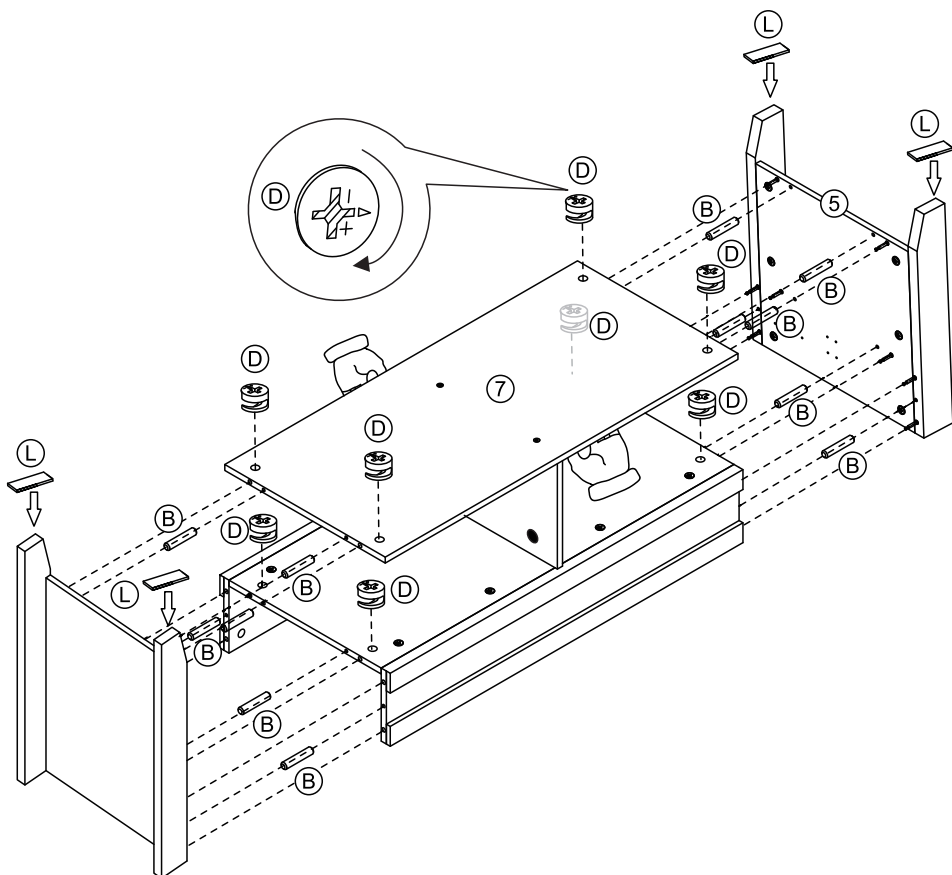
IT - Il montaggio richiede 2 adulti.





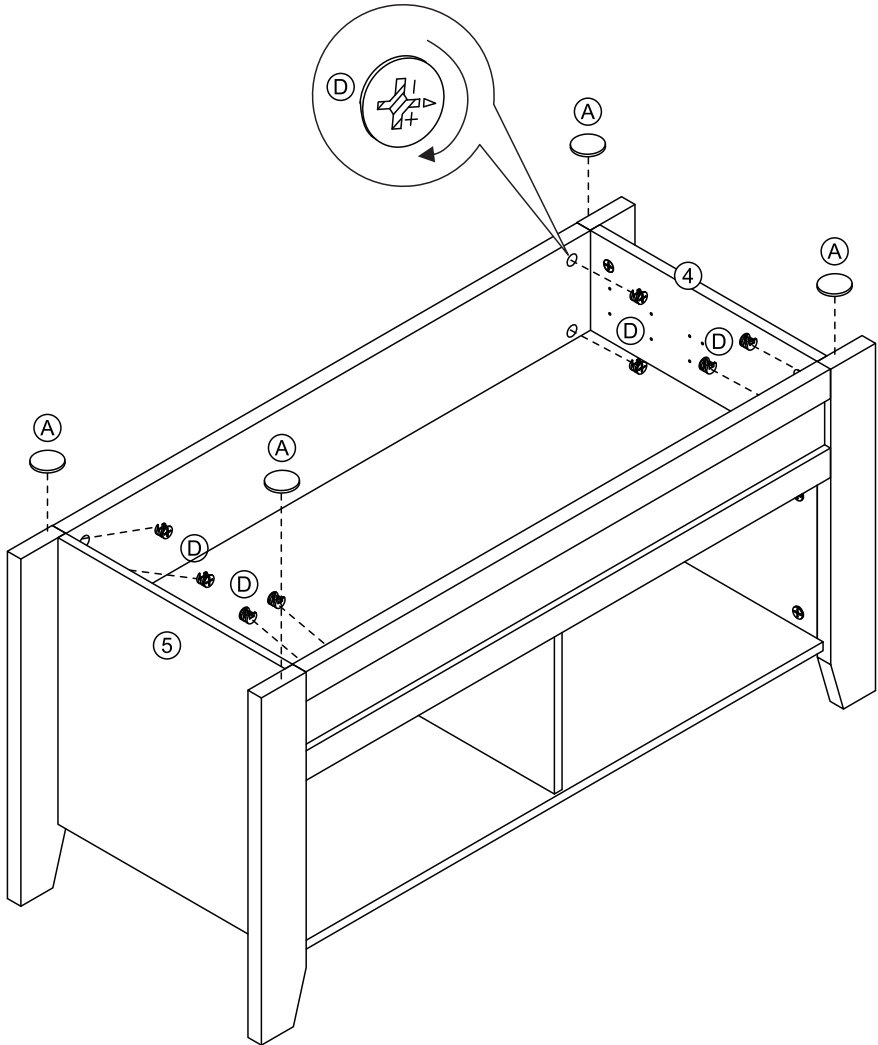

10

(A)		x4
(D)		x8



11

①	 X1
Ⓒ	 X12
Ⓘ	 X1
Ⓙ	 X1

EN - Please pay attention to the direction of Part (1) when installing.
DE - Bitte bei der Montage die Richtung von Teil (1) beachten.
ES - Por favor preste atención a la dirección de la pieza (1) al instalar.
FR - Veuillez à bien respecter l'orientation de l'élément (1) lors du montage.
IT - Si prega di fare attenzione al verso della parte (1) durante il montaggio.

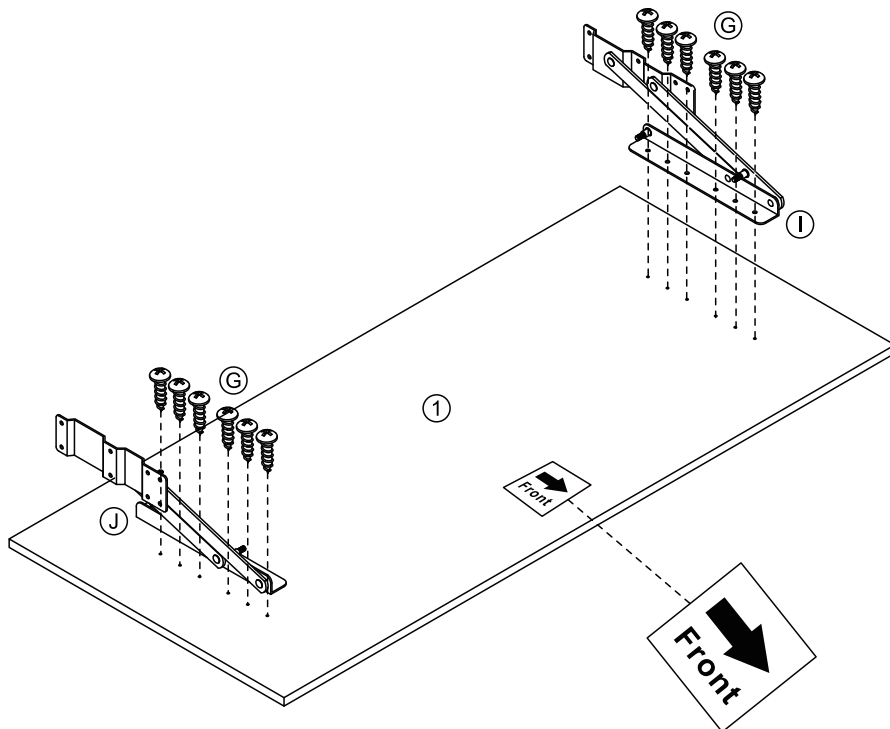

(K)		x2
(M)		x4

EN - When installing gas lift rod (K), please hold the handle and push it down with significant force to the corresponding hole.

DE - Wenn Sie die Gasdruckfeder (K) installieren, halten Sie bitte den Griff fest und drücken Sie ihn mit erheblichem Druck nach unten in das entsprechende Loch.

ES - Cuando instale la varilla de elevación de gas (K), sujete el asa y empújela hacia abajo con una fuerza considerable hasta el orificio correspondiente.

FR - Pour installer la tige de levage à gaz, maintenez fermement la poignée et poussez fortement vers le bas pour la faire entrer dans le trou correspondant.

IT - Durante il montaggio dell'asta di sollevamento (K), si prega di tenere la maniglia e premere con forza nella fessura corrispondente.

No.2

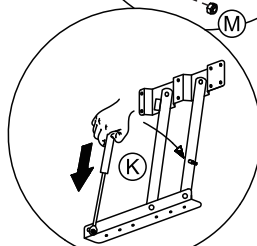
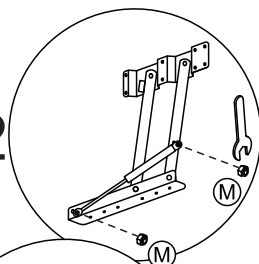

No.1

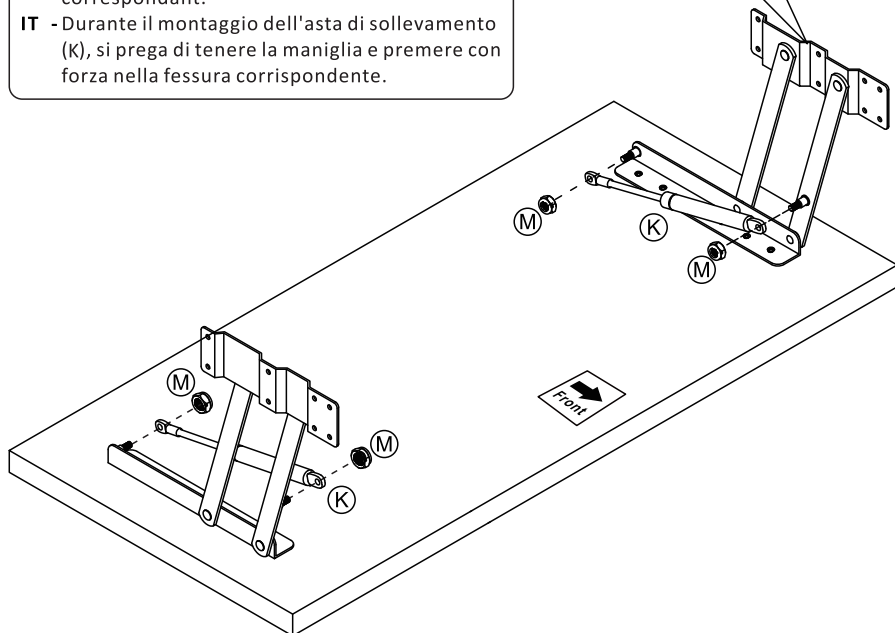

13

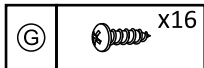

EN - Assembly requires 2 adults.
DE - Die Montage erfordert 2 Erwachsene.
ES - Para el montaje se necesitan 2 adultos.
FR - L'assemblage nécessite 2 adultes.
IT - Il montaggio richiede 2 adulti.

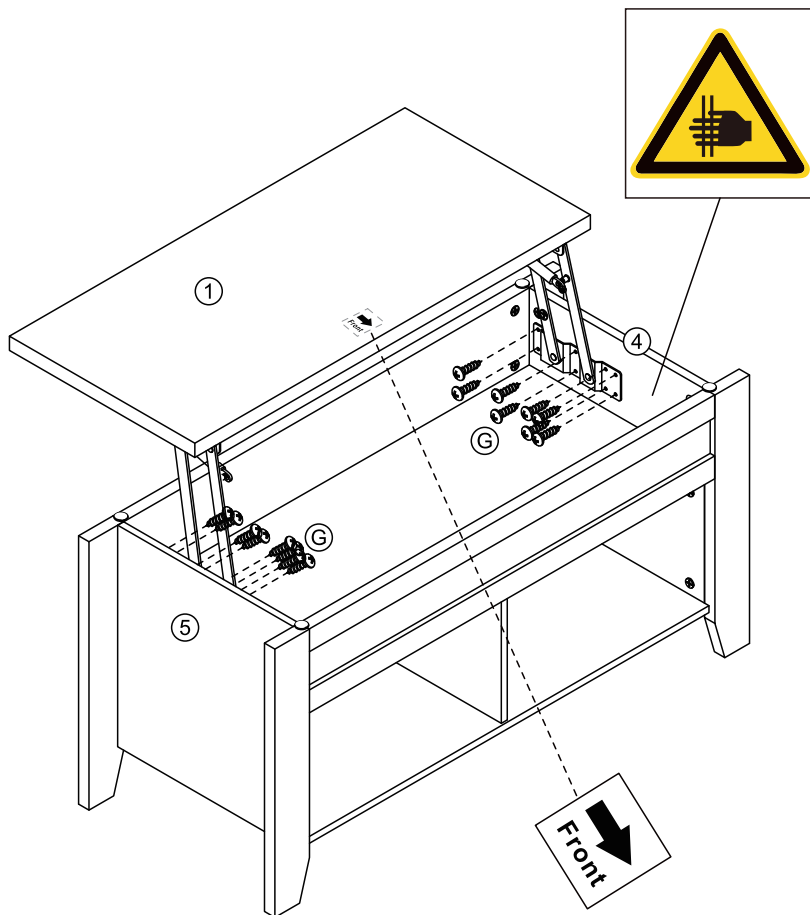

EN - Please pay attention to the direction of Part (1) when installing.
DE - Bitte bei der Montage die Richtung von Teil (1) beachten.
ES - Por favor preste atención a la dirección de la pieza (1) al instalar.
FR - Veuillez à bien respecter l'orientation de l'élément (1) lors du montage.
IT - Si prega di fare attenzione al verso della parte (1) durante il montaggio.

EN : Product Care Instructions

1. Use a soft, clean cloth or sponge to gently wipe the outer surface of the product to remove dust and dirt.
2. Avoid using chemical cleaners or harsh solvents to prevent damage to the appearance of the product.
3. Inspect the fittings (bolts, screws, nuts, etc.) every 3 months and re-tighten them every 6 months.
4. Avoid direct sunlight.

If the product shows structural damage or poses a safety hazard, stop using it until it is repaired.

DE : Pflegehinweise für Produkte

1. Benutzen Sie ein weiches, sauberes Tuch oder einen Schwamm, um behutsam die äußere Oberfläche des Geräts abzuwischen und Staub sowie Schmutz zu entfernen.
 2. Vermeiden Sie die Verwendung von chemischen Reinigern oder scharfen Lösungsmitteln, um das Aussehen des Produkts nicht zu beschädigen.
 3. Alle 3 Monate sollten Sie die Beschläge wie Bolzen, Schrauben, Muttern usw. überprüfen und alle 6 Monate nachziehen.
 4. Es ist ratsam, direkte Sonneneinstrahlung zu vermeiden.
- Sollte das Produkt strukturelle Schäden aufweisen oder ein Sicherheitsrisiko darstellen, sollte es nicht mehr verwendet werden, bis es repariert ist.

ES : Instrucciones para Cuidado del Producto

1. Utilizar un paño o una espuma suave y limpia para limpiar ligeramente la superficie exterior del producto y eliminar el polvo y la suciedad.
2. Evitar el uso de limpiadores químicos o disolventes fuertes para evitar dañar la apariencia del producto.
3. Comprobar los herrajes (pernos, tornillos, tuercas, etc.) cada 3 meses y volver a apretarlos cada 6 meses.
4. Evitar la luz solar directa.

Si el producto presenta daños estructurales o posibilidad de peligro para la seguridad, deja de utilizarlo hasta que sea reparado.

FR : Instructions d'entretien du Produit

1. Utilisez un chiffon doux et propre ou une éponge pour essuyer délicatement la surface extérieure du produit afin d'éliminer la poussière et la saleté.
2. Évitez l'utilisation de produits chimiques de nettoyage ou de solvants agressifs afin de préserver l'apparence du produit.
3. Inspectez les raccords (boulons, vis, écrous, etc.) tous les 3 mois et resserrez-les tous les 6 mois si nécessaire.
4. Évitez l'exposition directe aux rayons du soleil.

Si le produit présente des dommages structurels ou un risque pour la sécurité, cessez de l'utiliser jusqu'à ce qu'il soit réparé.

IT: Istruzioni per la cura del prodotto

1. Utilizzare un panno morbido, pulito o una spugna per pulire delicatamente la superficie esterna del prodotto e rimuovere polvere e sporco.
2. Evitare l'uso di detergenti chimici o solventi aggressivi per prevenire danni all'aspetto del prodotto.
3. Controllare le ferramenta (bulloni, viti, dadi, ecc.) ogni 3 mesi e serrarli nuovamente ogni 6 mesi.
4. Evitare la luce diretta del sole.

Se il prodotto mostra danni strutturali o rappresenta un pericolo per la sicurezza, smettere di usarlo fino a quando non viene riparato.

EN



If you are not entirely satisfied with your purchase, please feel free to contact us using the following steps:

1. Go to Your Orders.
2. Find your order in the list.
3. Select Problem with order.
4. Choose your topic from list displayed.
5. Select Contact seller.

Please contact us at: info@yaheetech.shop

DE



Sollten Sie mit Ihrem Kauf nicht zufrieden sein, nehmen Sie bitte in folgenden Schritten mit uns Kontakt auf:

1. Gehen Sie auf die Bestellseite
2. Suchen Sie Ihre Bestellung in der Bestellliste
3. Schildern Sie das Problem mit der Bestellung
4. Thema aus der angezeigten Liste auswählen
5. Kontakt mit dem Verkäufer aufnehmen.

Kontaktieren Sie uns unter: info@yaheetech.shop

ES



Si no está totalmente satisfecho con su compra, no dude en ponerse en contacto con nosotros siguiendo las siguientes instrucciones:

1. Vaya a la lista de sus ordenes de compra.
2. Localice su pedido en la lista.
3. Seleccione el problema en el pedido.
4. Elija un tema de la lista que se muestra.
5. Seleccione Contactar con el vendedor.

Póngase en contacto con nosotros en: info@yaheetech.shop

FR



Si vous n'êtes pas satisfait de votre achat, veuillez nous contacter en procédant comme suit :

1. Allez sur "Vos commandes"
2. Trouvez votre commande dans la liste.
3. Cliquez sur "Signaler un problème"
4. Sélectionnez une catégorie dans la liste déroulante.
5. Cliquez sur "Contactez le vendeur"

Veuillez nous contacter à l'adresse suivante : info@yaheetech.shop

IT



Se non siete soddisfatti di questa esperienza dello shopping, non esitate a contattarci per i seguenti passaggi:

1. Vai ai tuoi ordini.
2. Selezionare "l'ordine interessato".
3. Selezionare il problema con l'ordine.
4. Scegli il tuo argomento dalla lista visualizzata.
5. Selezionare "contatta il venditore".

Contattaci all'indirizzo: info@yaheetech.shop