

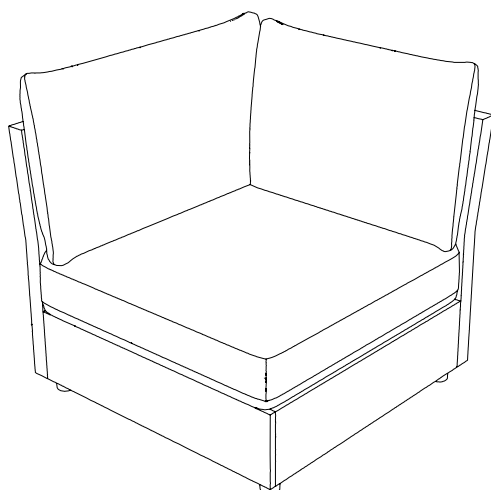

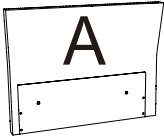

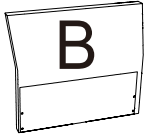

ASSEMBLY INSTRUCTION

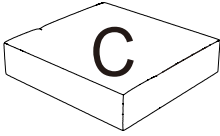

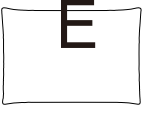

ITEM NO.:D88083-D88084-D88085-D88086-C

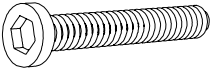

PARTS LIST

 <p>A Backrest x1</p>	 <p>B Backrest x1</p>	 <p>C Seat cushion x1</p>	 <p>D Back cushion x1</p>
 <p>E Back cushion x1</p>	 <p>F Base Frame Front Panel x1</p>	 <p>G Base Frame Side Panel x1</p>	 <p>H Support Bar x2</p>
 <p>M Slats x1</p>			

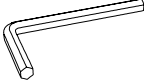
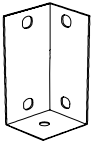
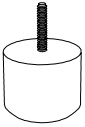
HARDWARE LIST

 <p>1 1/4*1.8cm x16</p>	 <p>2 1/4*4.5cm x4</p>	 <p>3 19mm x4</p>	 <p>5 40mm*100mm x1</p>
 <p>7 x4</p>	 <p>8 x4</p>	 <p>9 x2</p>	

BEFORE ASSEMBLY

Open up Velcro of Non-Woven Fabric cover on the bottom to remove hardware, legs and parts.

1. Please open the black woven fabric with Velcro closure on the bottom of the frame then cut off the black straps before removing the parts for assembly.
2. After removing the cushion from the compress bag, please allow air to flow through the cushion for few days. You can try to fluff cushion by push in and push out on all four sides of the cushion. Hitting the top/front of the cushion with your hand to fluff them after installation.
3. Please allow at least 24 hours for the cushions to recover to its natural state after removing from the package.

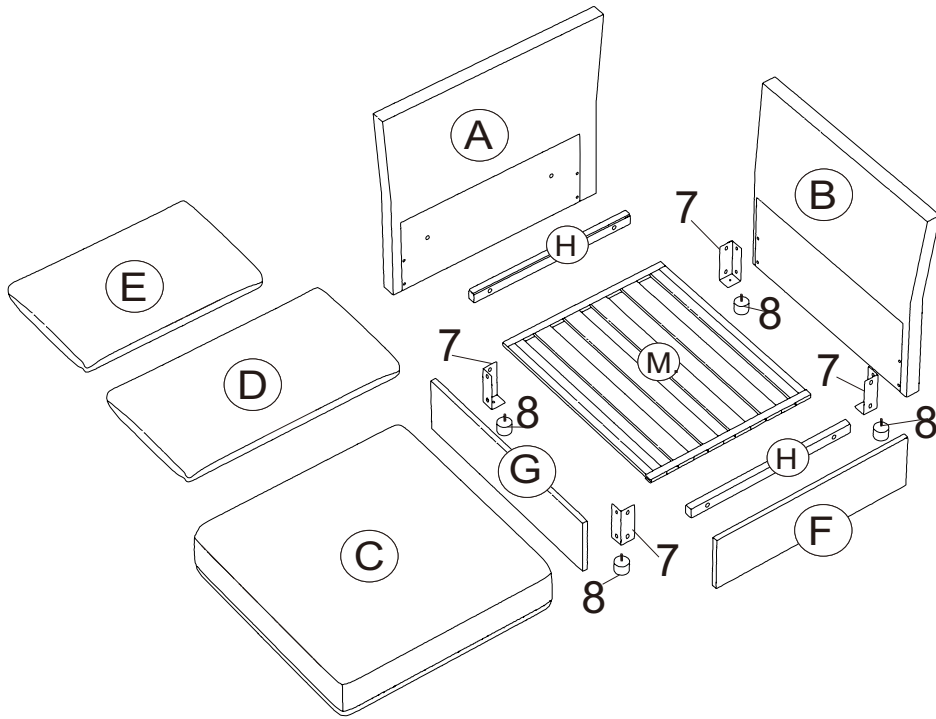
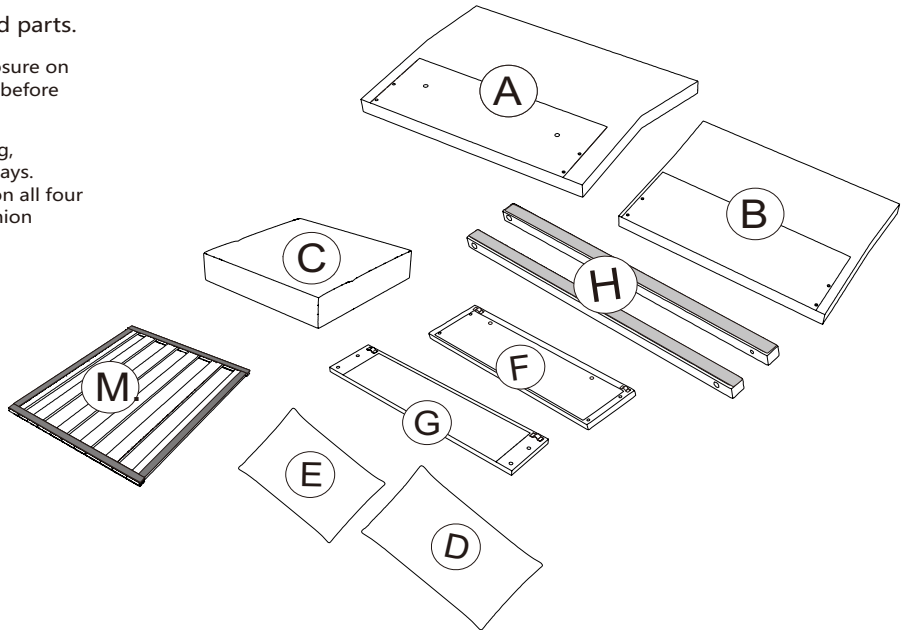
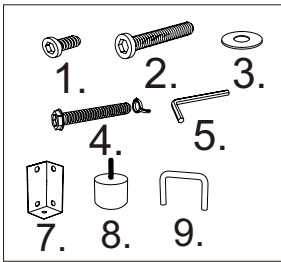

SOFA ASSEMBLY INSTRUCTION

Step1

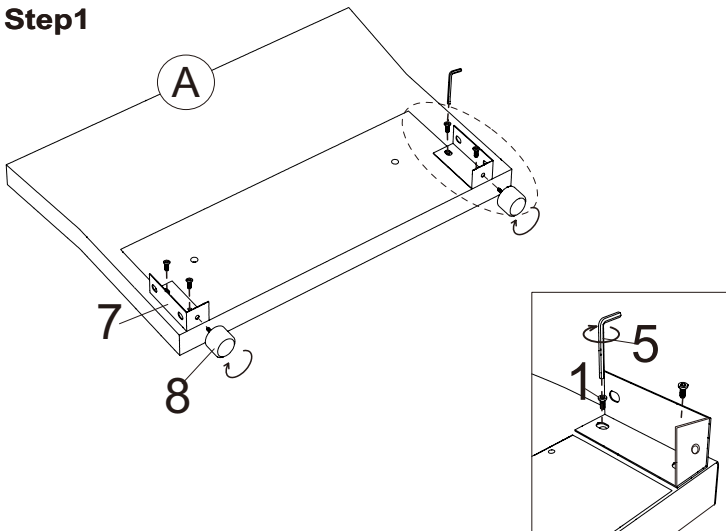

Step2

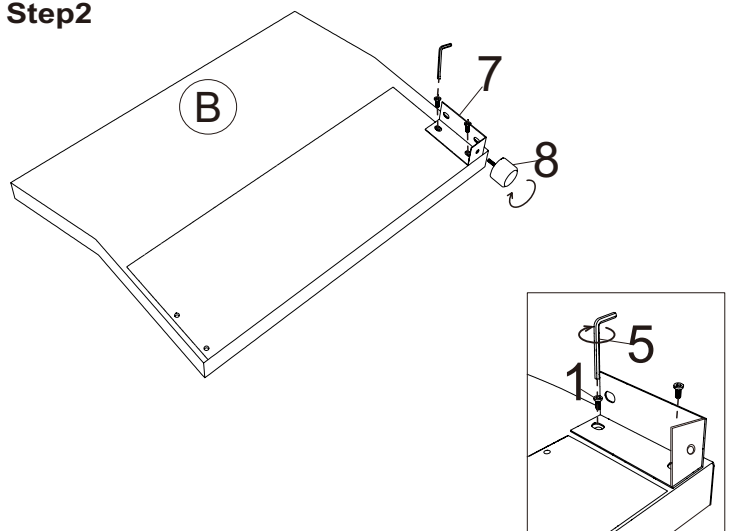

Step3

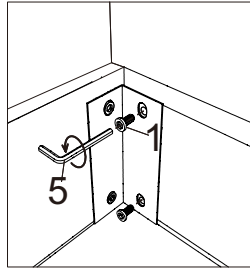
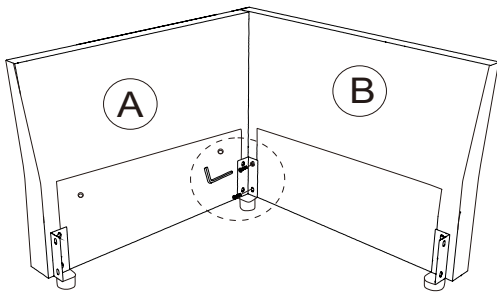

Step4

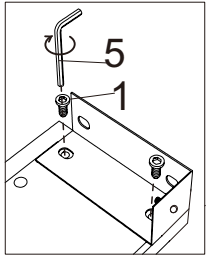
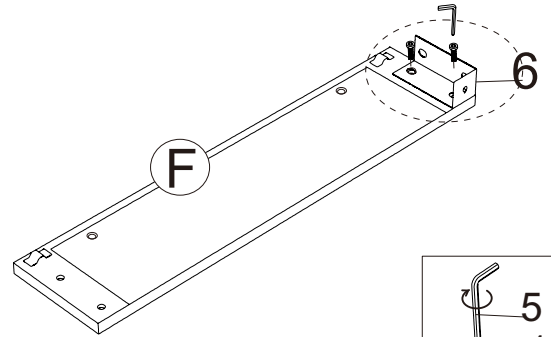

Step5

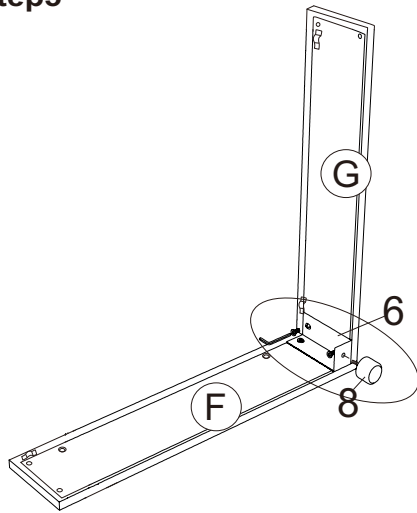

Make sure to align Part#F,G, and 7 at the same level. If there is any issue, use the oval screw holes to adjust.

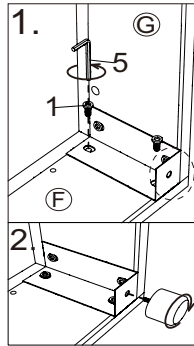

Step6

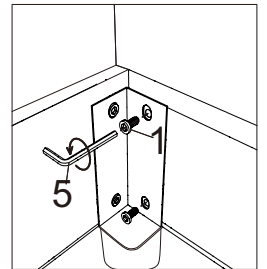
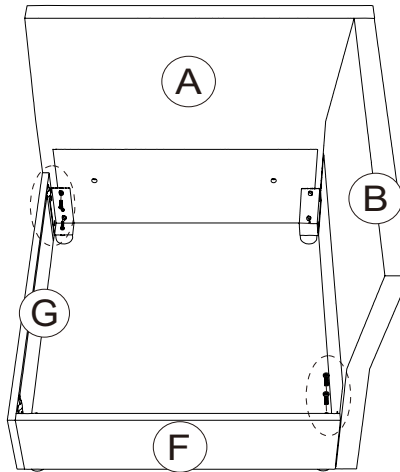

Step7

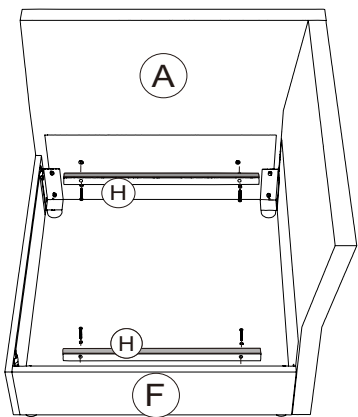

Face the Velcro upward.

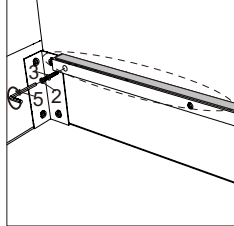

Step8

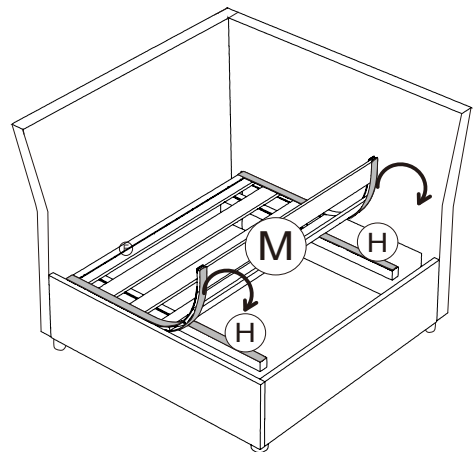

Step9

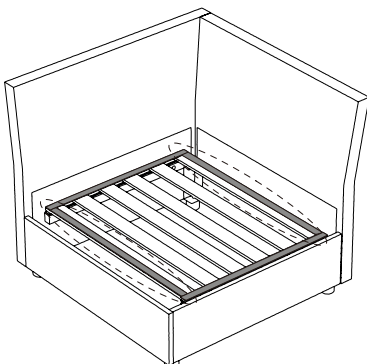

Face the Velcro upward.

Step10

