

# 3+2 Drawers Chest

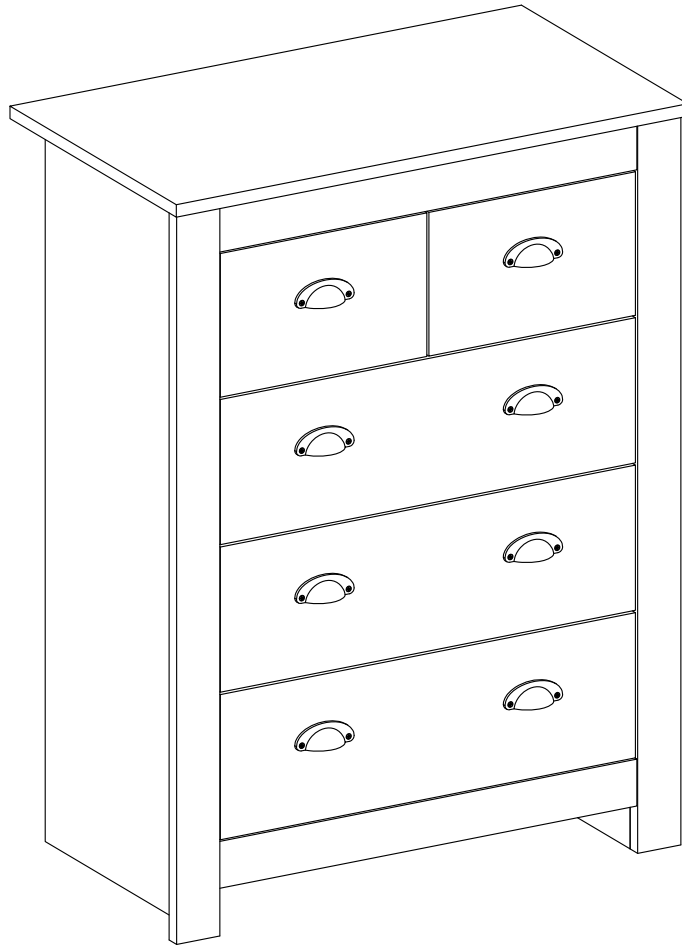

USER MANUAL | MODE D'EMPLOI | MANUAL DEL USUARIO | GEBRAUCHSANLEITUNG |  
GEBRUIKSHANDLEIDING | MANUALE PER L'UTENTE | MANUAL DO UTILIZADOR





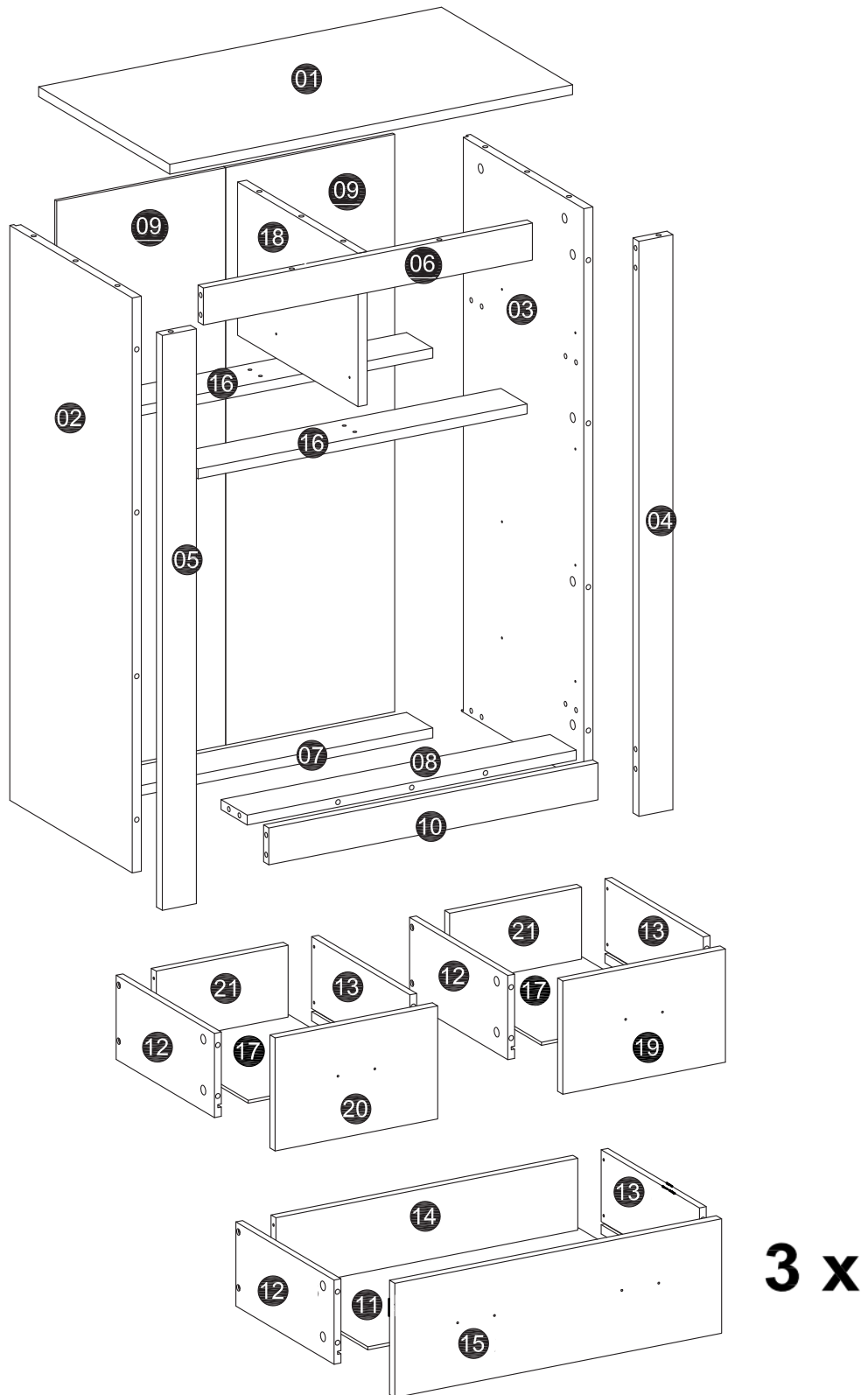

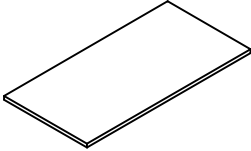
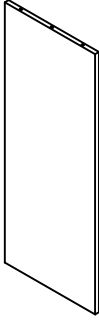
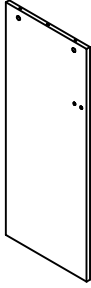

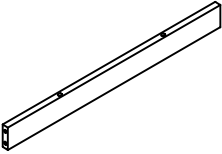
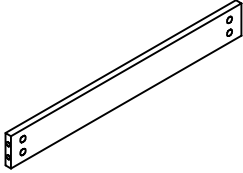
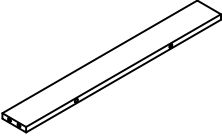
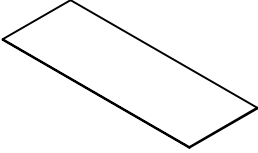
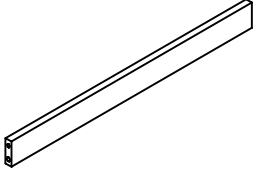
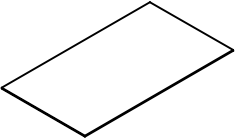
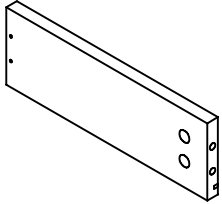
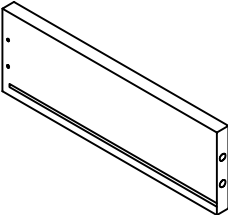
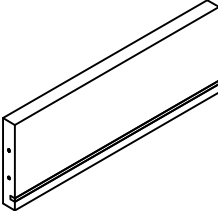
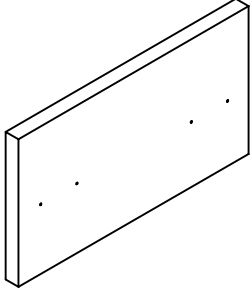
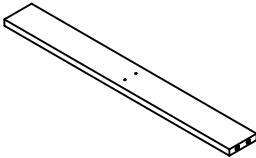
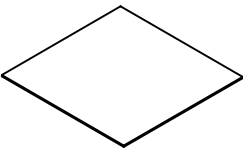
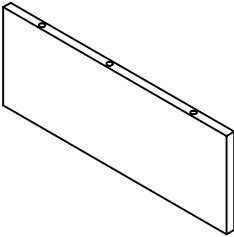
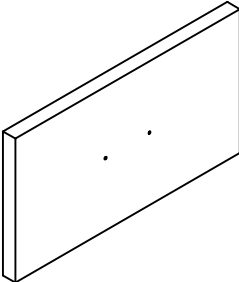
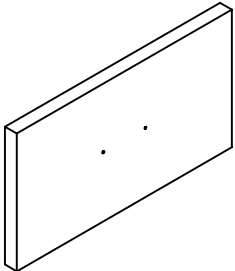
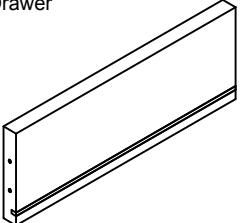
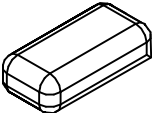

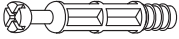



**Warning:**

Please do not use an electric drill, thank you for your cooperation!

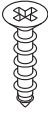

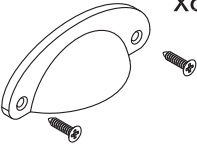

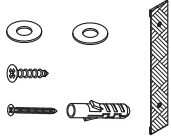

<p>Description:Top Panel Qty:1</p>  <p>①790×400×15mm</p>	<p>Description:Side Panel-L Qty:1</p>  <p>②934×378×15mm</p>	<p>Description:Side Panel-R Qty:1</p>  <p>③934×378×15mm</p>	<p>Description:Frame Bar-R Qty:1</p>  <p>④934×60×18mm</p>	<p>Description:Frame Bar-L Qty:1</p>  <p>⑤934×60×18mm</p>
<p>Description:Brow Furrow Qty:1</p>  <p>⑥660×60×15mm</p>	<p>Description: Bottom Bar-Back Qty:1</p>  <p>⑦661×80×15mm</p>	<p>Description:Bottom Bar-Front Qty:1</p>  <p>⑧661×60×15mm</p>	<p>Description:Back Panel Qty:2</p>  <p>⑨947×344×3mm</p>	<p>Description:Baseboard Qty:1</p>  <p>⑩660×60×15mm</p>
<p>Description:Bottom of Big Drawer Qty:3</p>  <p>⑪612×343×3mm</p>	<p>Description:Drawer Side Panel-L Qty:5</p>  <p>⑫350×120×15mm</p>	<p>Description:Drawer Side Panel-R Qty:5</p>  <p>⑬350×120×15mm</p>	<p>Description:Back of Big Drawer Qty:3</p>  <p>⑭606×120×15mm</p>	<p>Description: Drawer Front-Big Qty:3</p>  <p>⑮656×183×15mm</p>
<p>Description:Center bar Qty:2</p>  <p>⑯661×80×15mm</p>	<p>Description: Bottom of Small Drawer Qty:2</p>  <p>⑰343×278×3mm</p>	<p>Description:Upper Erector Qty:1</p>  <p>⑱378×240×15mm</p>	<p>Description:Drawer Front-R Qty:1</p>  <p>⑲325×181×15mm</p>	<p>Description:Drawer Front-L Qty:1</p>  <p>⑳325×181×15mm</p>
<p>Description: Back of Small Drawer Qty:2</p>  <p>㉑268×120×15mm</p>	<p>Description:All Fixings Qty:1</p>  <p>㉒230×380×30mm</p>			

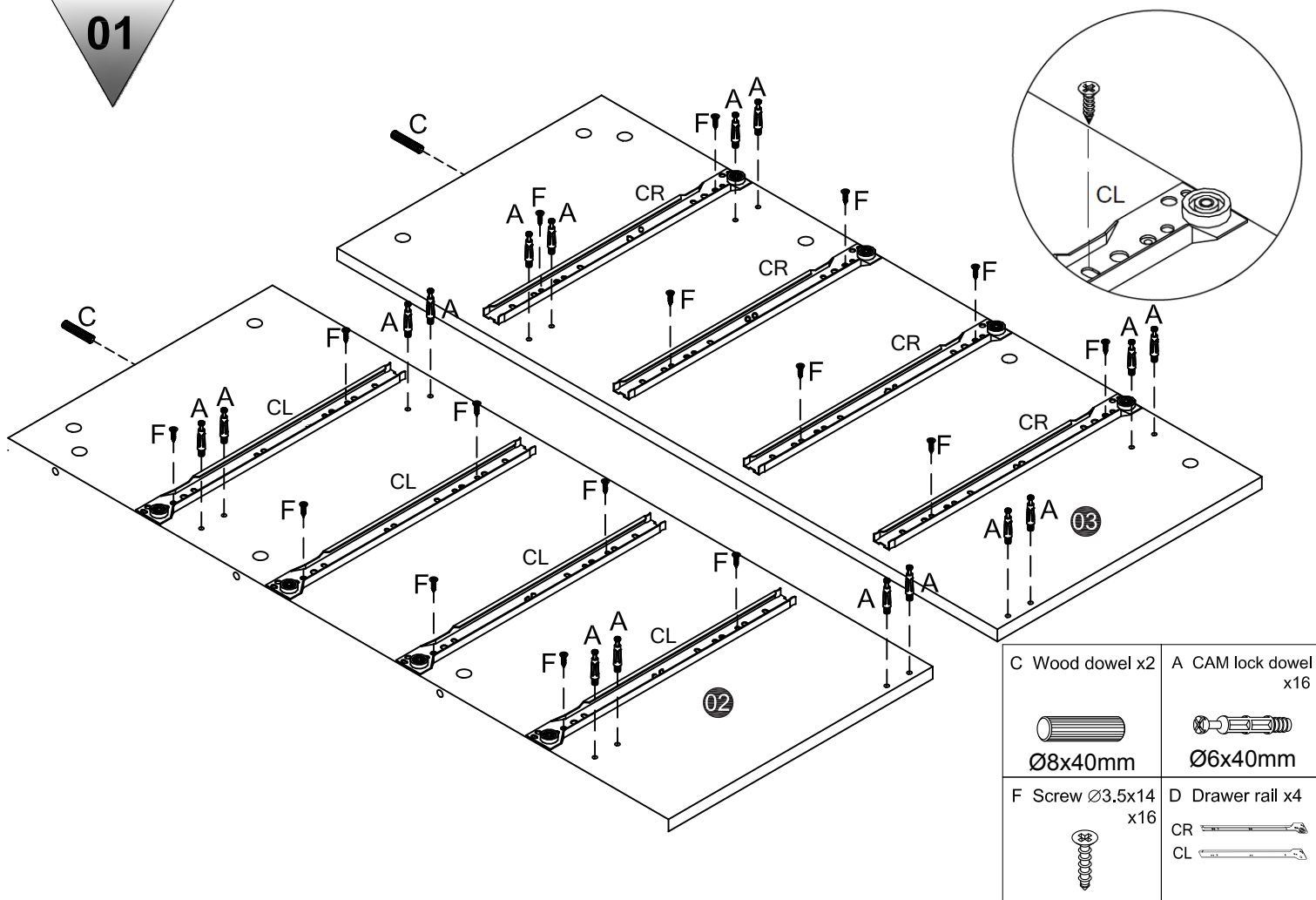
<p>A CAM lock dowel Ø6x40mm x60</p> 	<p>B CAM lock x60 Ø15x20mm</p> 	<p>C Wood dowel x8 Ø8x40mm</p> 	<p>D Drawer rail x5</p> <p>CR </p> <p>CL </p> <p>DR </p> <p>DL </p>	<p>E Screw Ø3.5x35 x24</p> 
<p>F Screw Ø3.5x14 x40</p> 	<p>G Nail x40</p> 	<p>H Handle&amp;Screw x8</p> 	<p>I Nail Leg x4</p> 	<p>J Anti-falling accessory x1</p> 

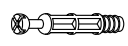



01

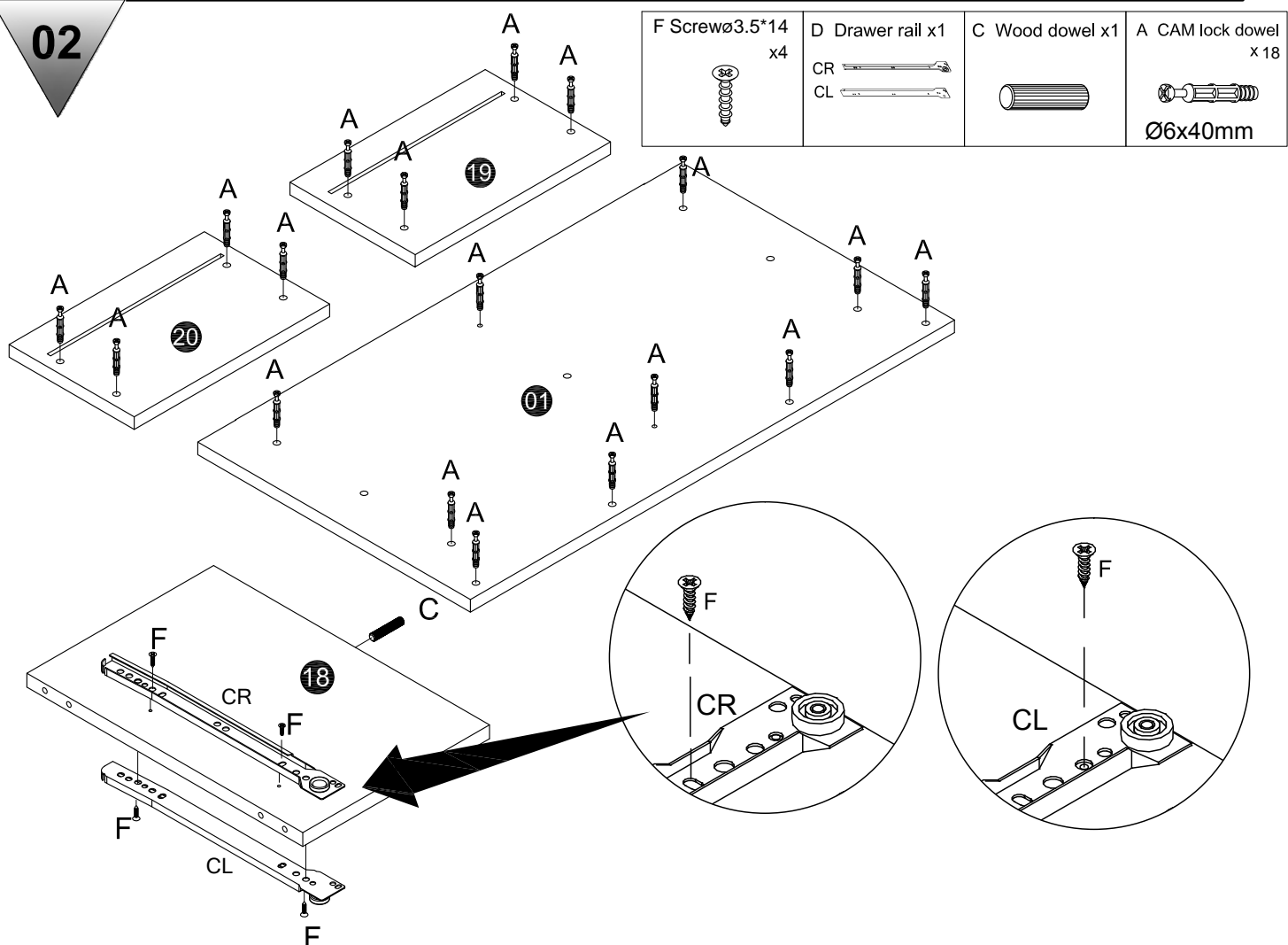

C Wood dowel x2  Ø8x40mm	A CAM lock dowel x16  Ø6x40mm
F Screw Ø3.5x14 x16 	D Drawer rail x4 CR  CL 

02

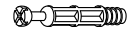

F Screw Ø3.5*14 x4 	D Drawer rail x1 CR  CL 	C Wood dowel x1  Ø8x40mm	A CAM lock dowel x18  Ø6x40mm
---	--	---	--

03

C Wood dowel x2 Ø8x40mm	A CAM lock dowel x24 Ø6x40mm
----------------------------	------------------------------------

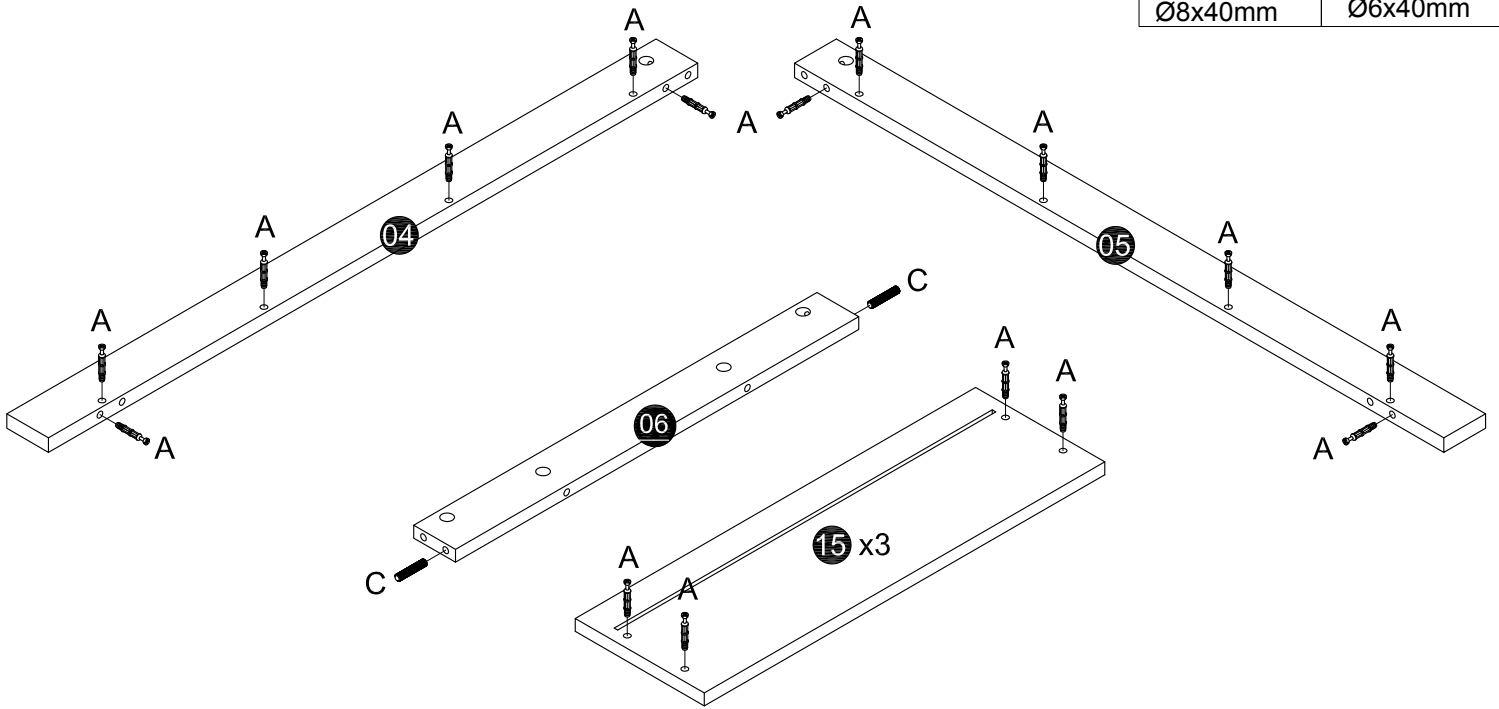

04

C Wood dowel x3 Ø8x40mm	B CAM lock x2 Ø15x20mm	A CAM lock dowel x2 Ø6x40mm
----------------------------	---------------------------	-----------------------------------

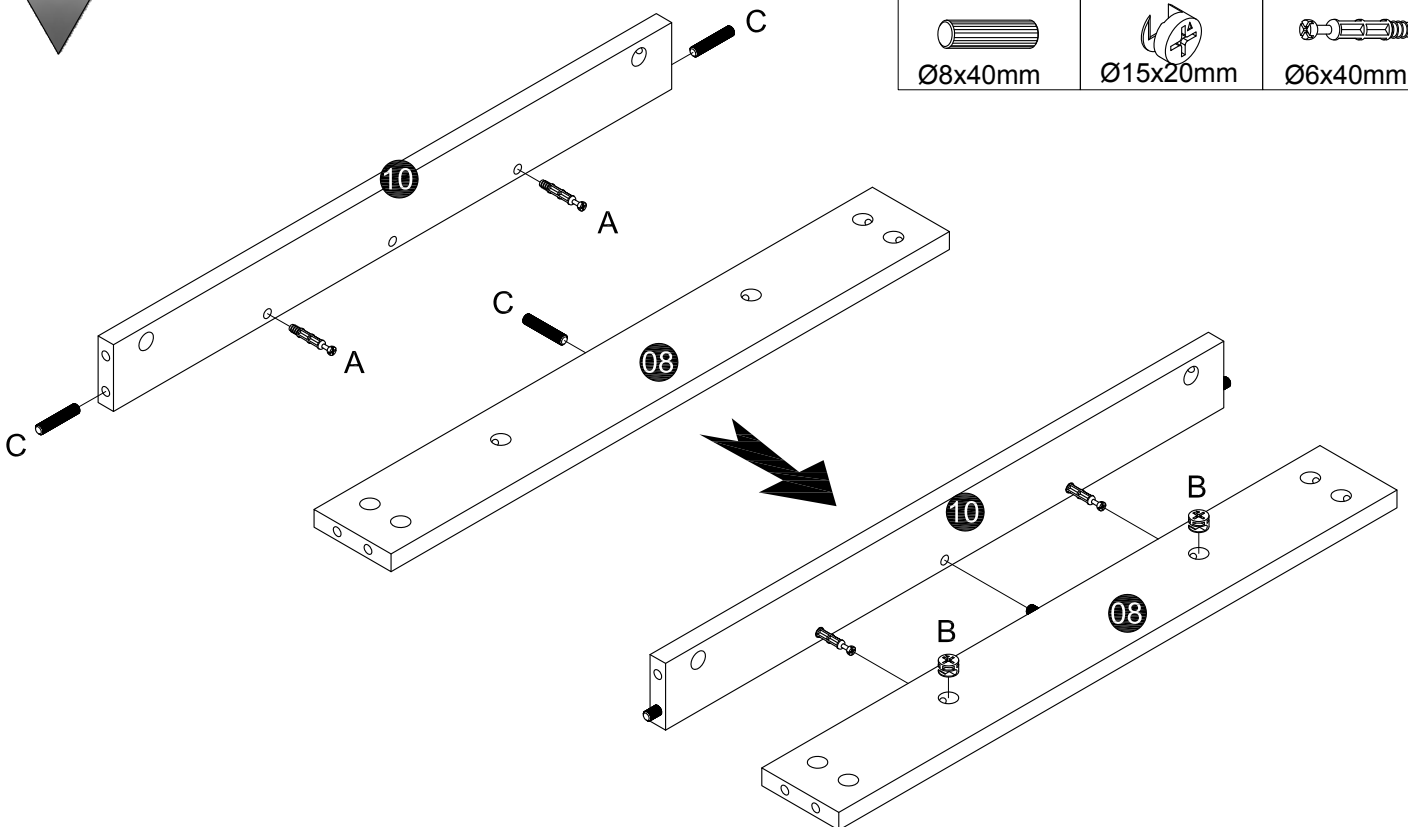

05

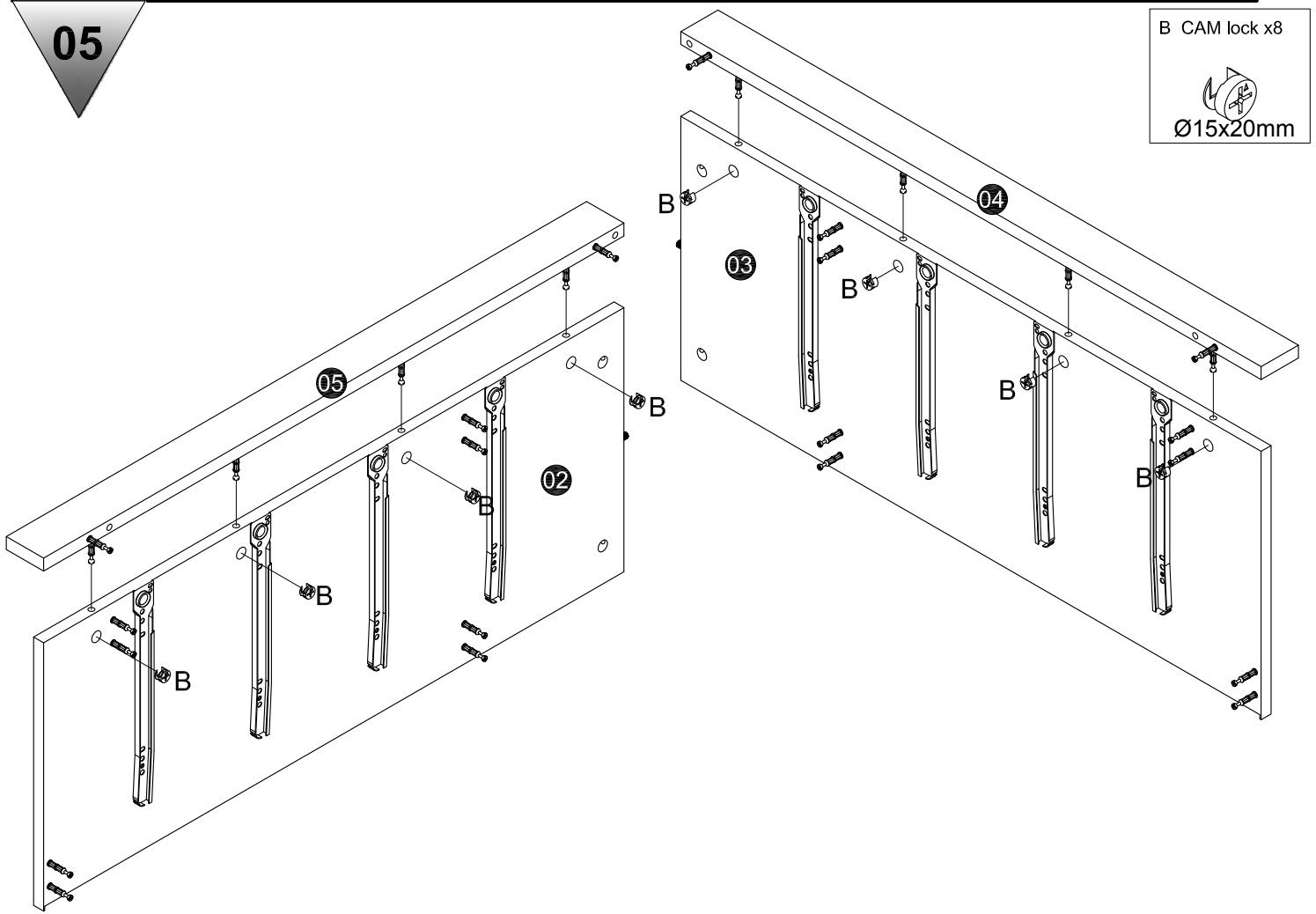

06

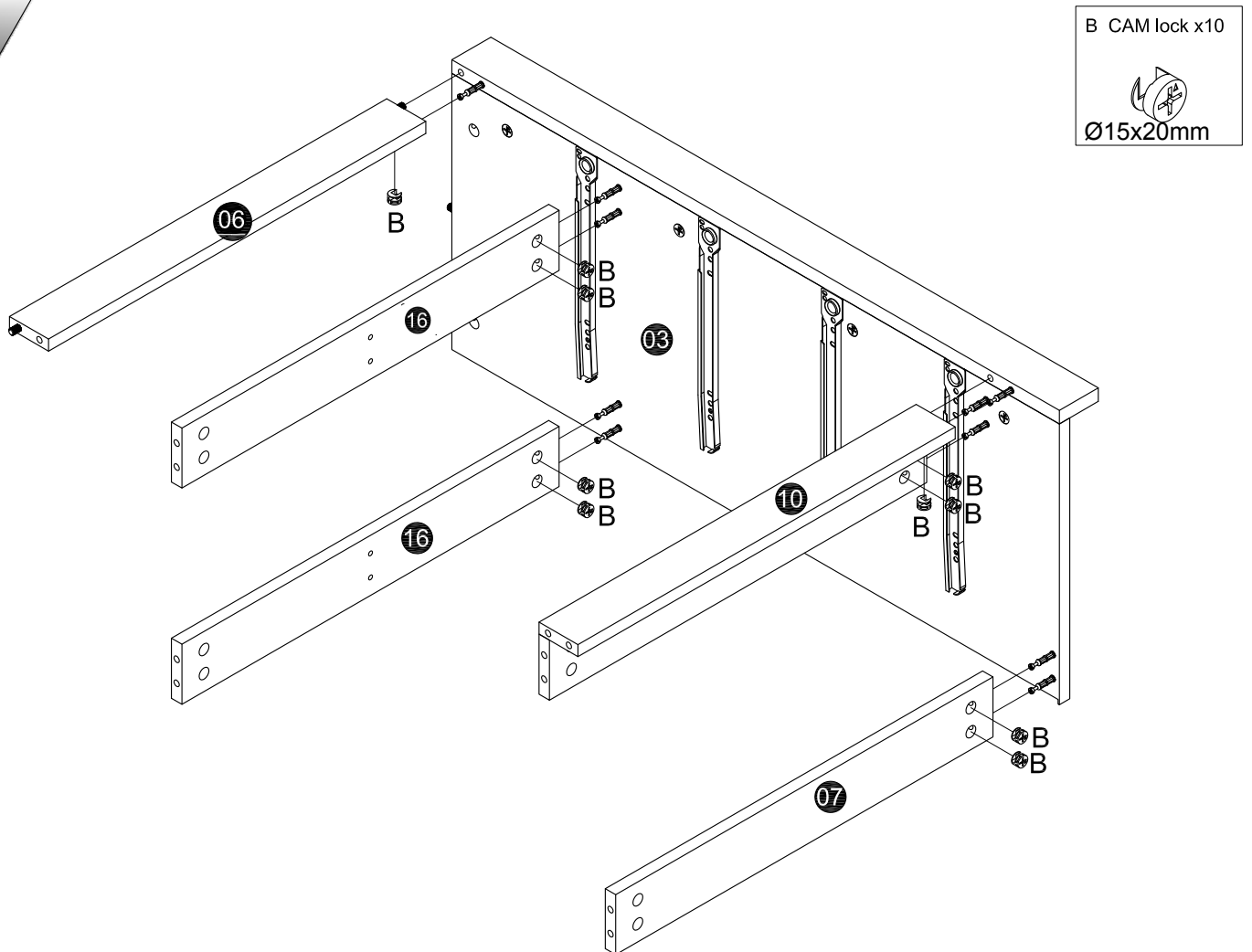

07

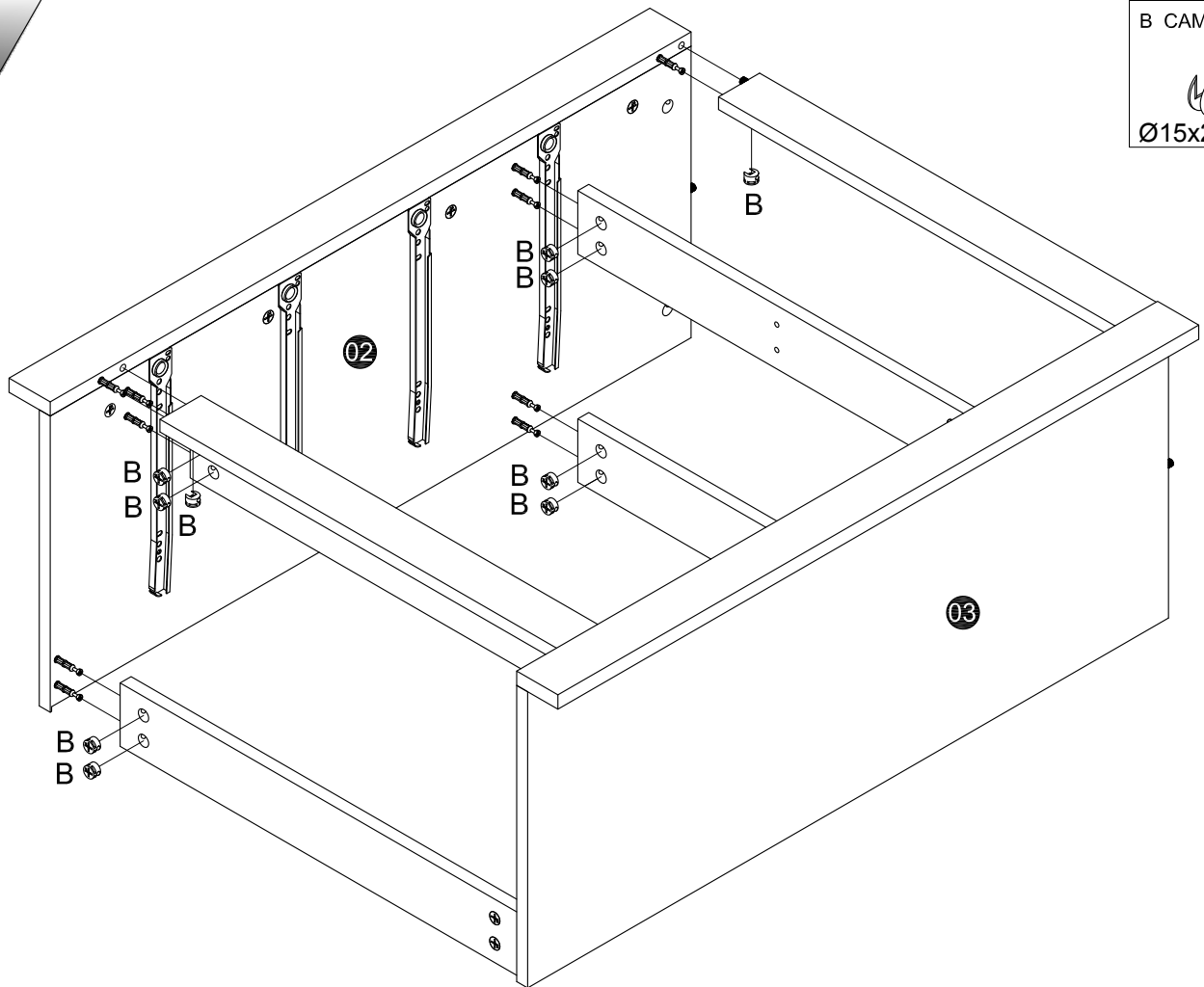

B CAM lock x10



Ø15x20mm

08

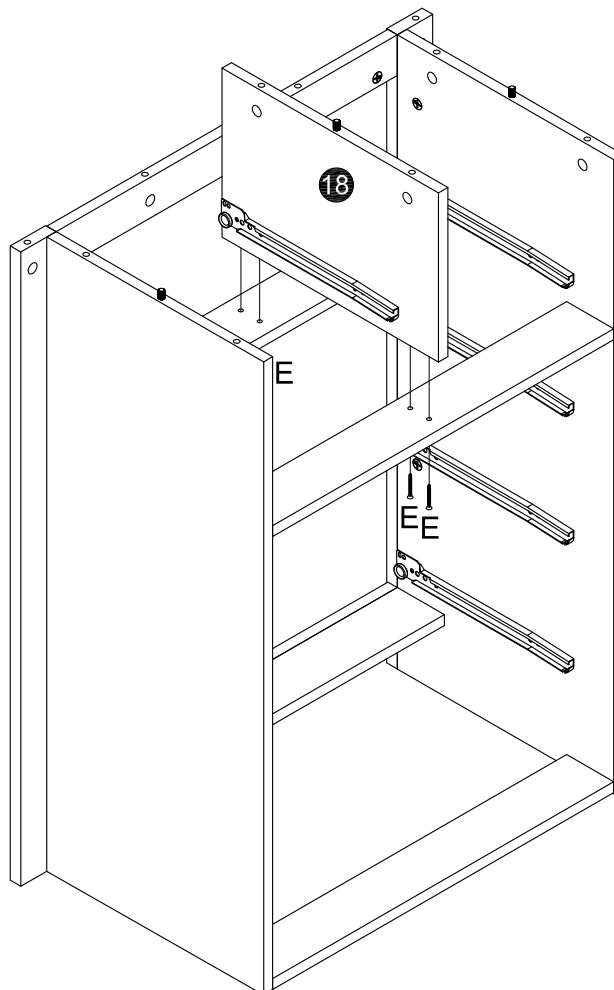

E Screw  $\varnothing 3.5 \times 35$   
x4

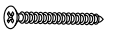

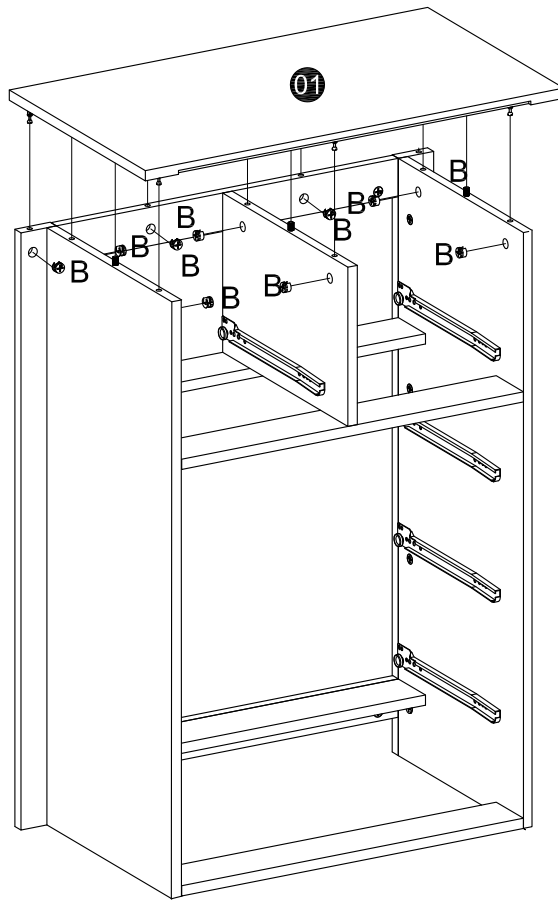

09

B CAM lock x10



10

I Nail Leg	x4	G Nail
		

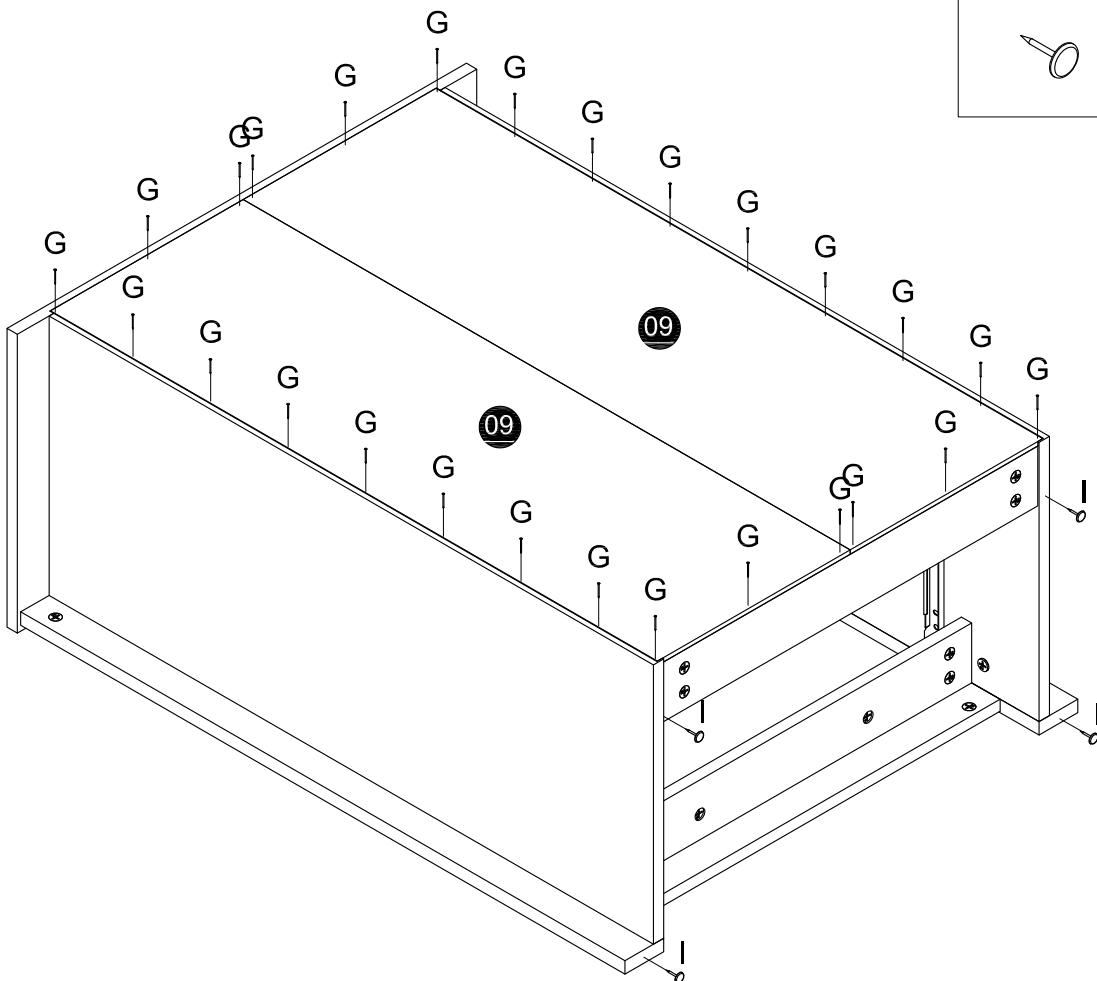

11

E Screw  $\varnothing 3.5 \times 35$   
x12

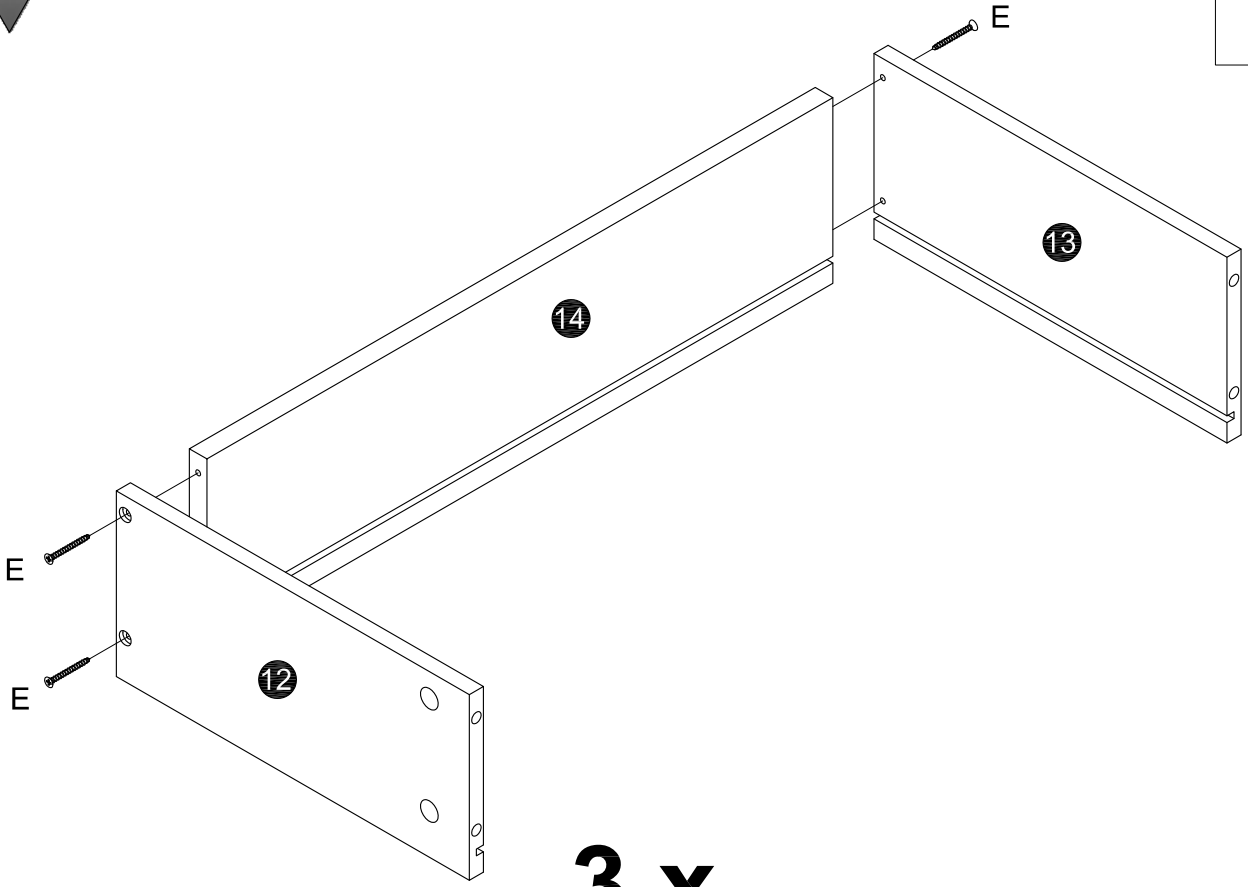
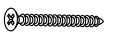

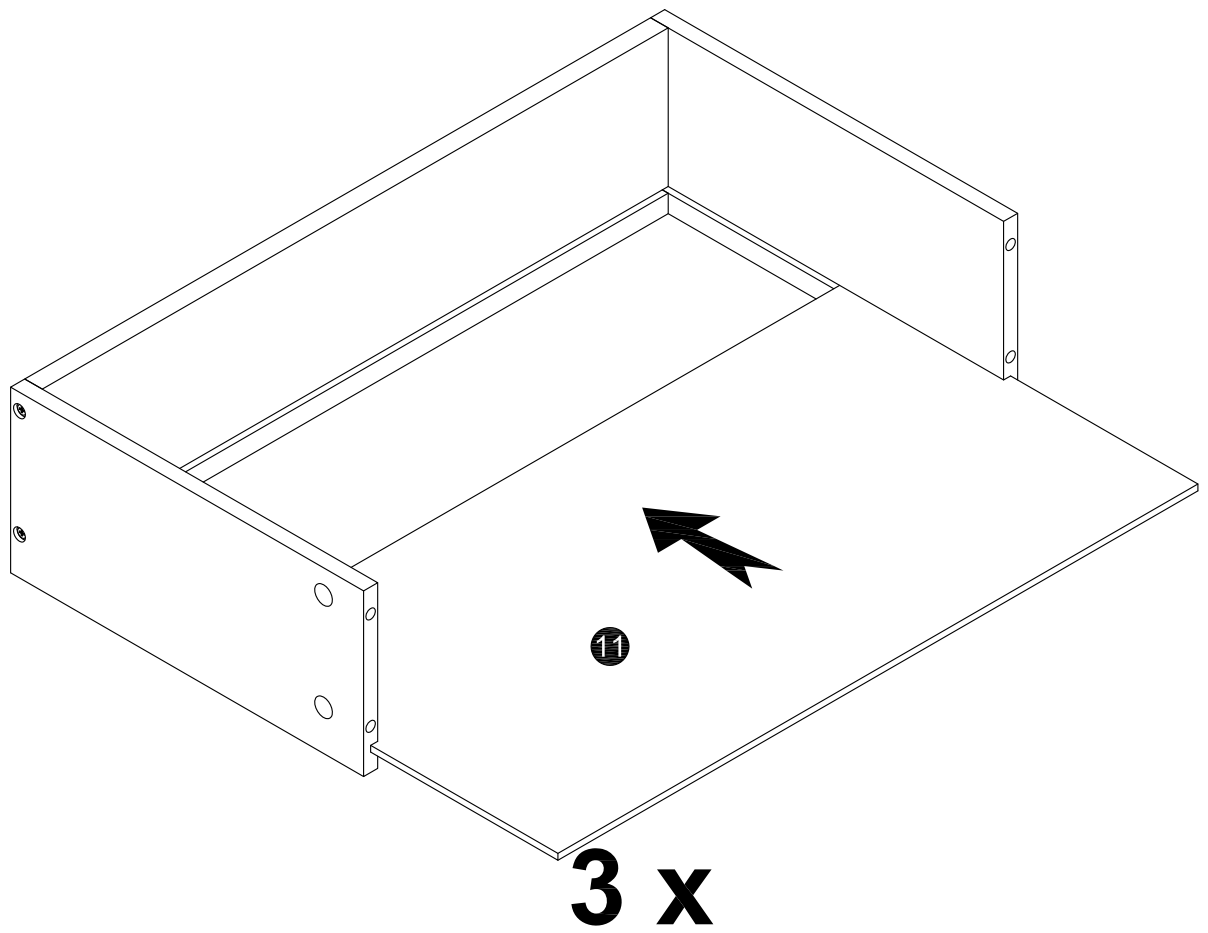

12



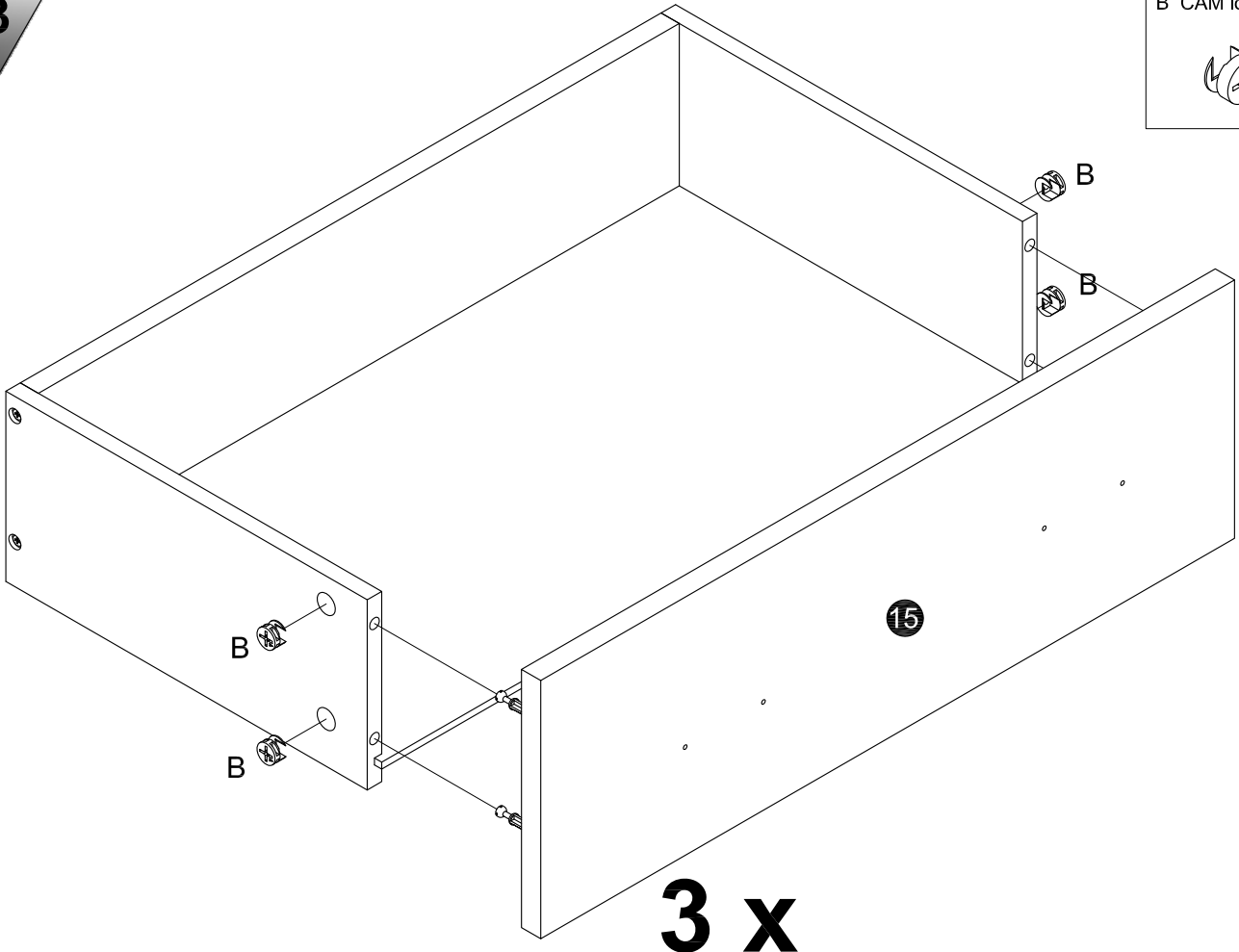

13

B CAM lock x12

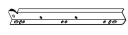

14

F Screw  $\varnothing 3.5 \times 14$  x12  
D Drawer rail x3  
DR   
DL 

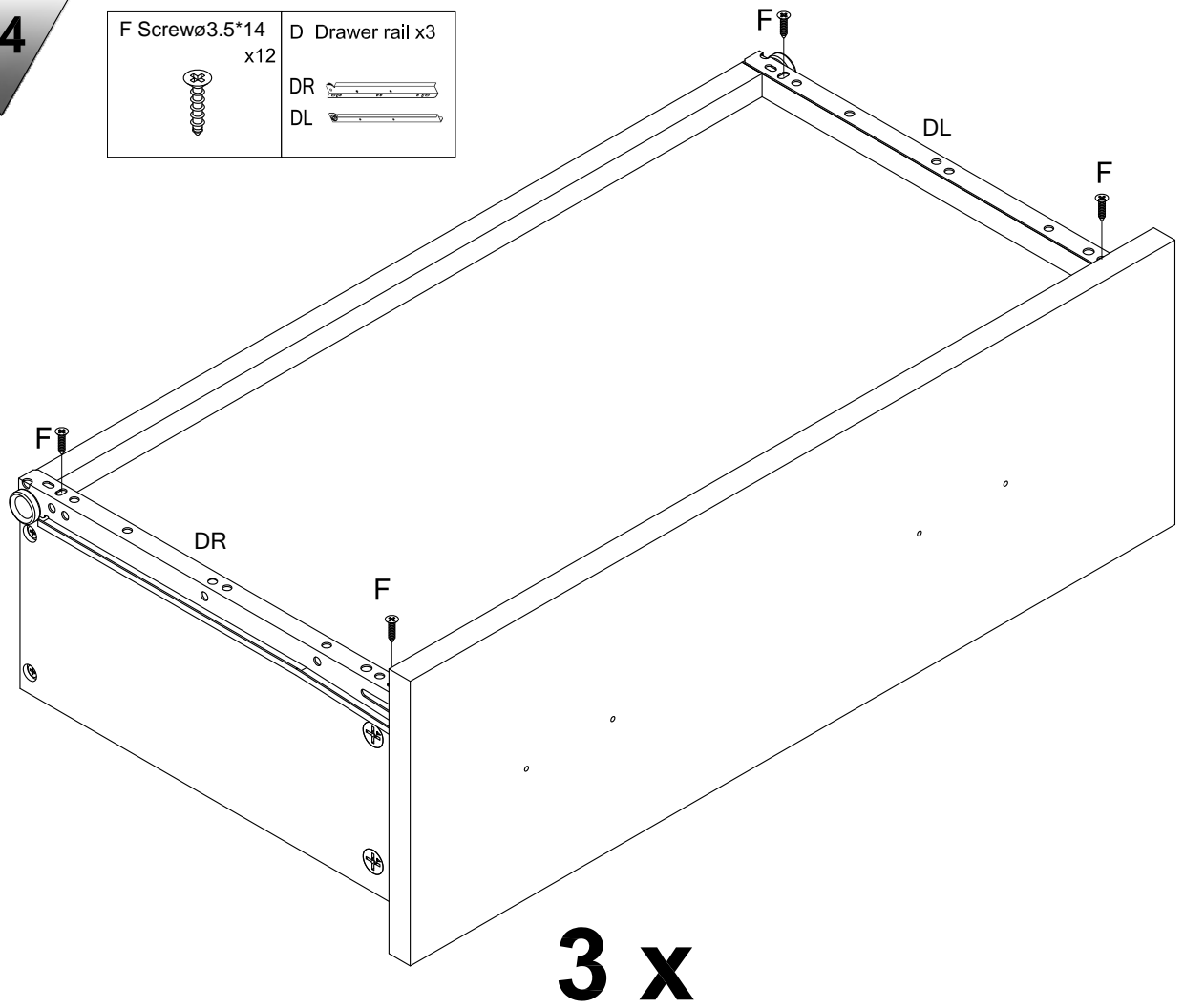

15

H Handle&Screw  
x6

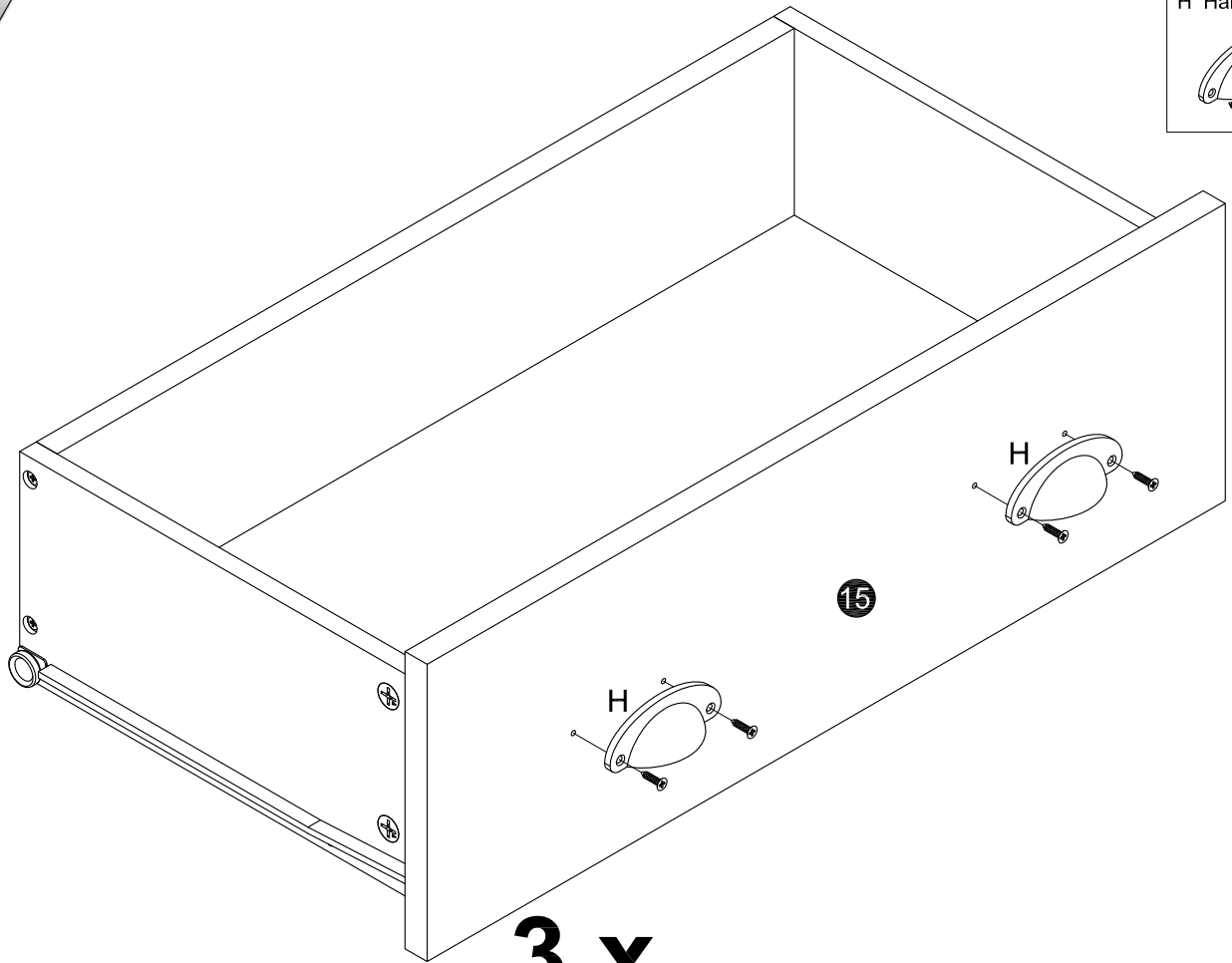

3 x

16

E Screw  $\varnothing 3.5 \times 35$   
x8

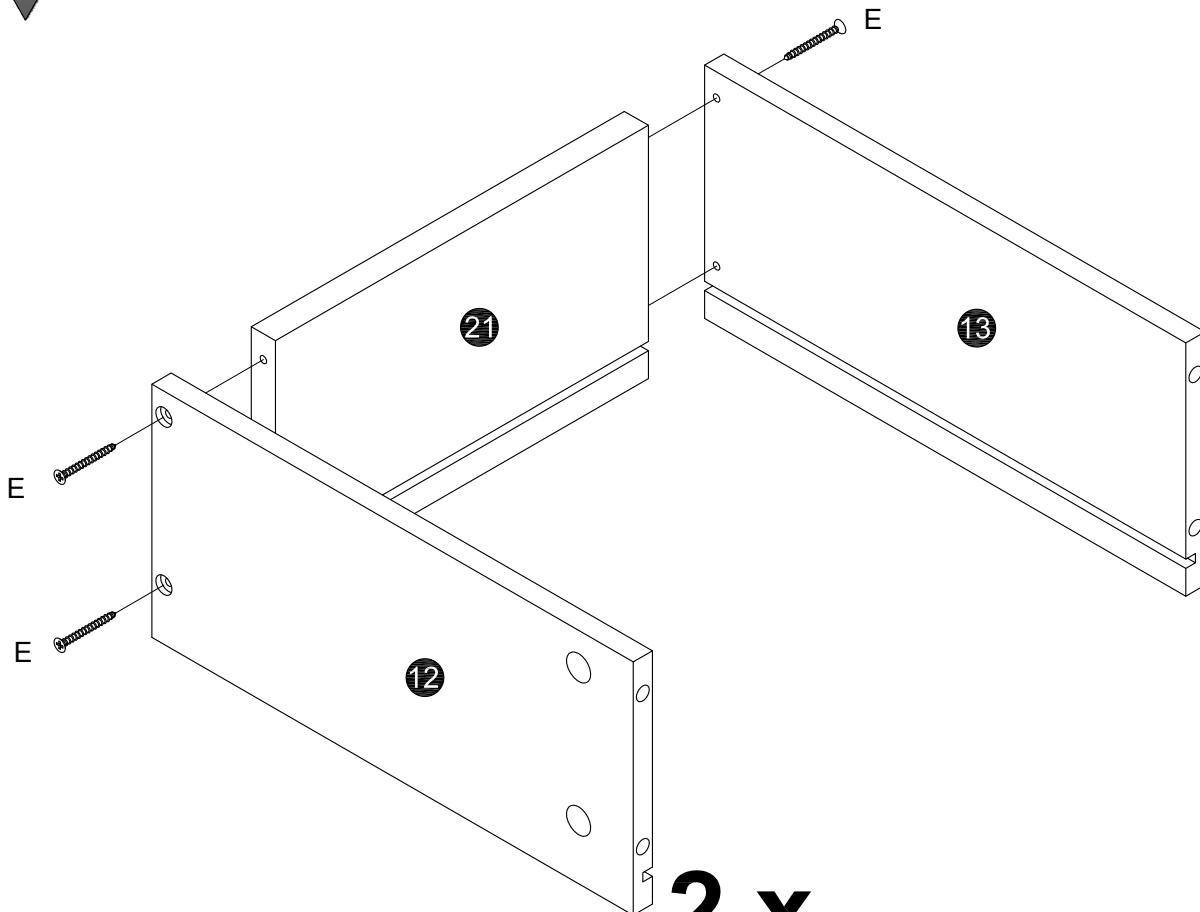
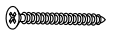

2 x

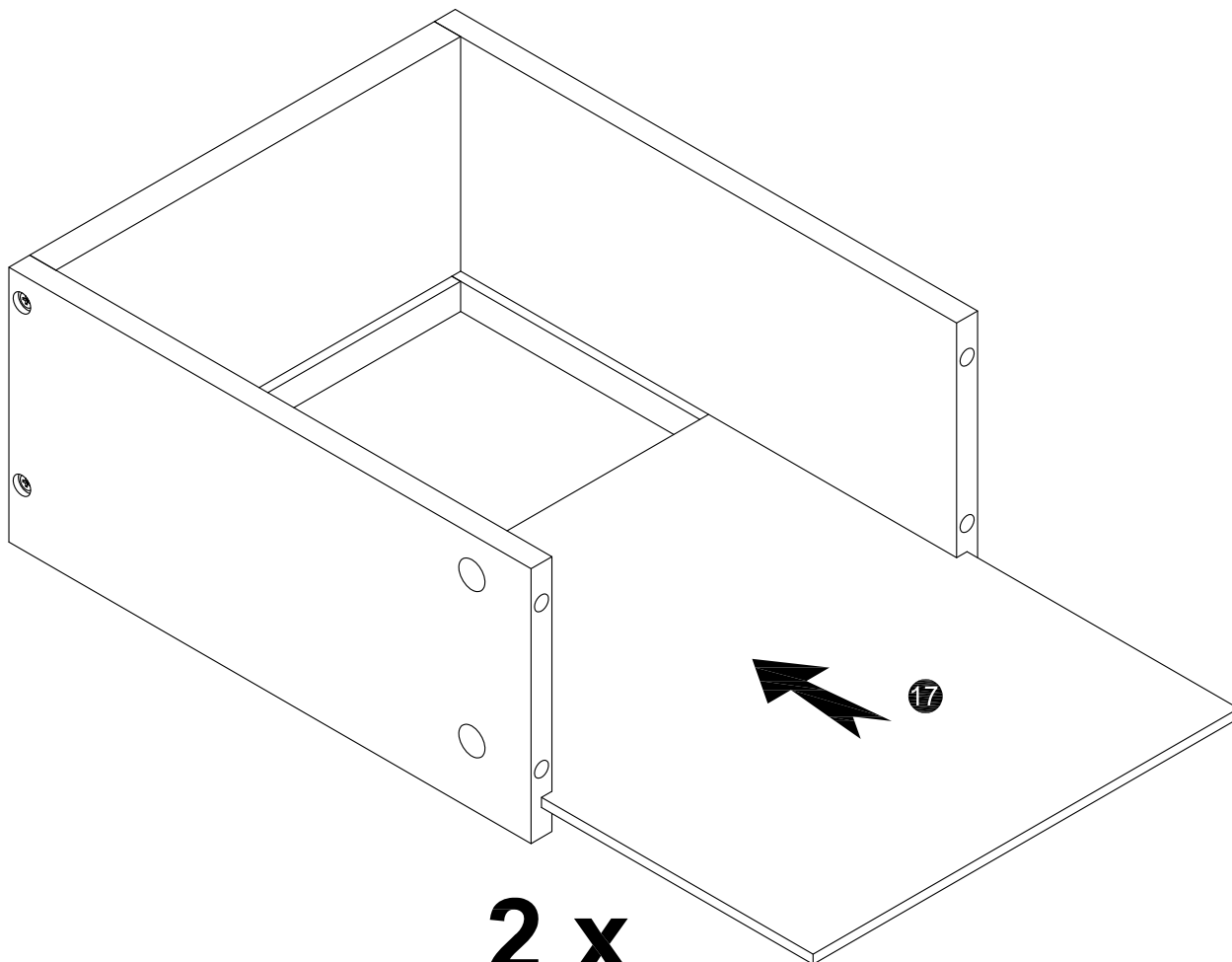

17

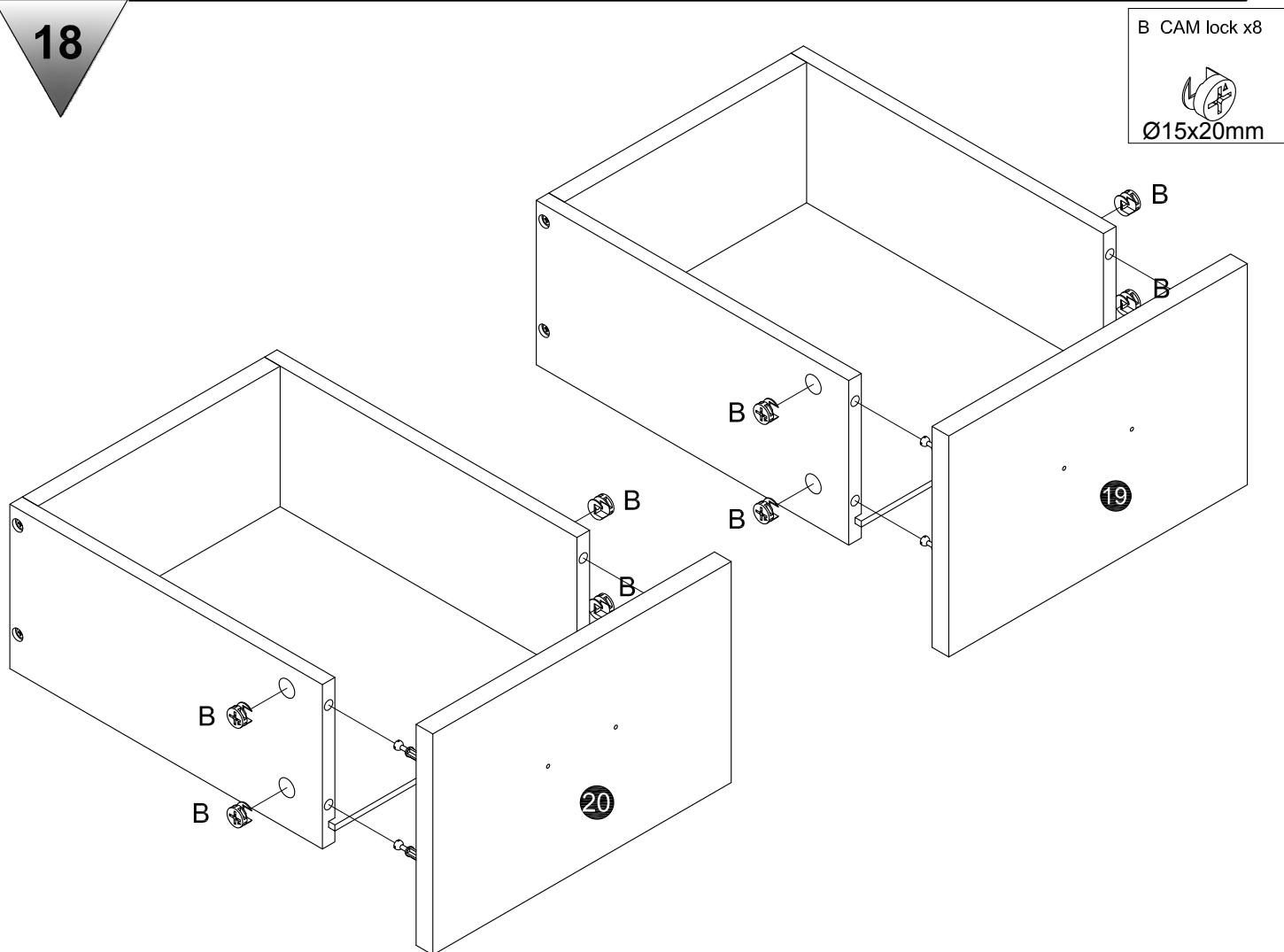

18

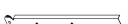

19

F Screw $\varnothing 3.5 \times 14$ x8 	D Drawer rail x2 DR  DL 
--	--

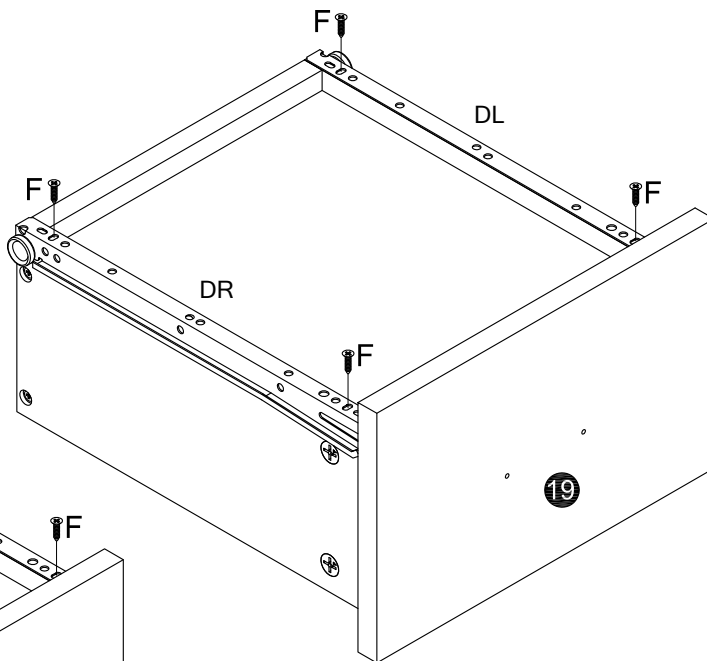
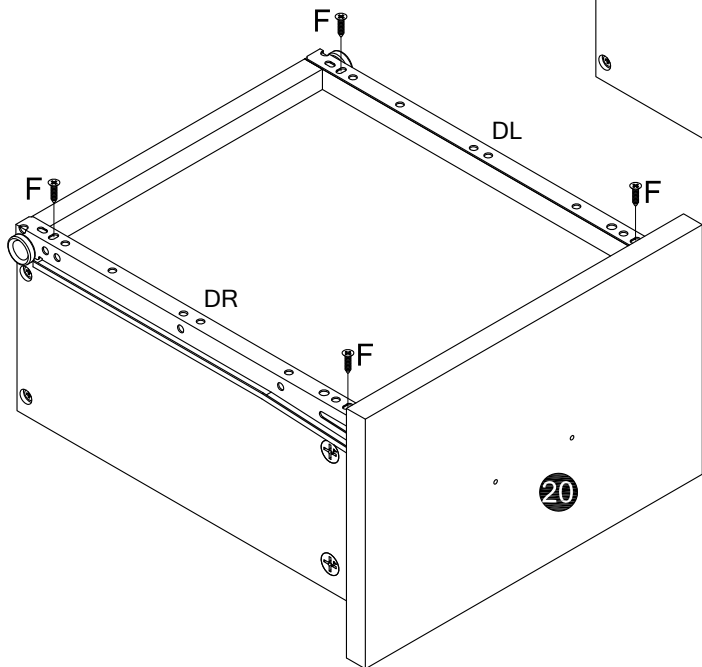

20

H Handle & Screw x2 
---

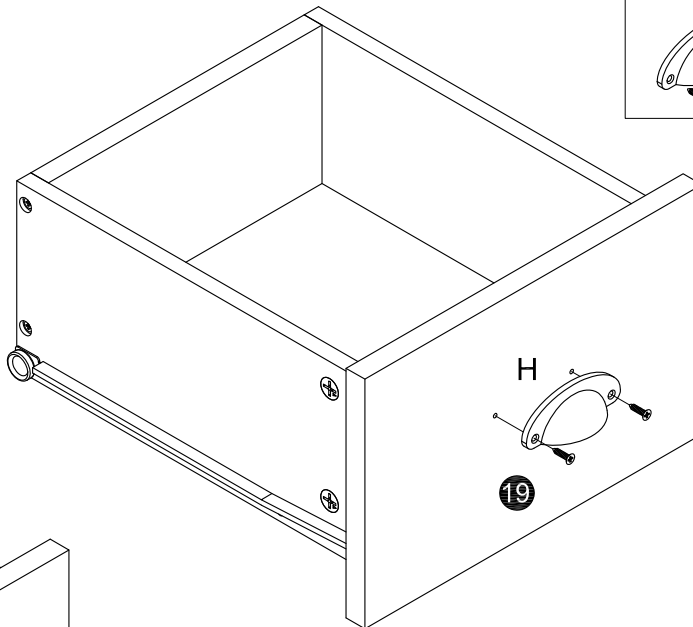
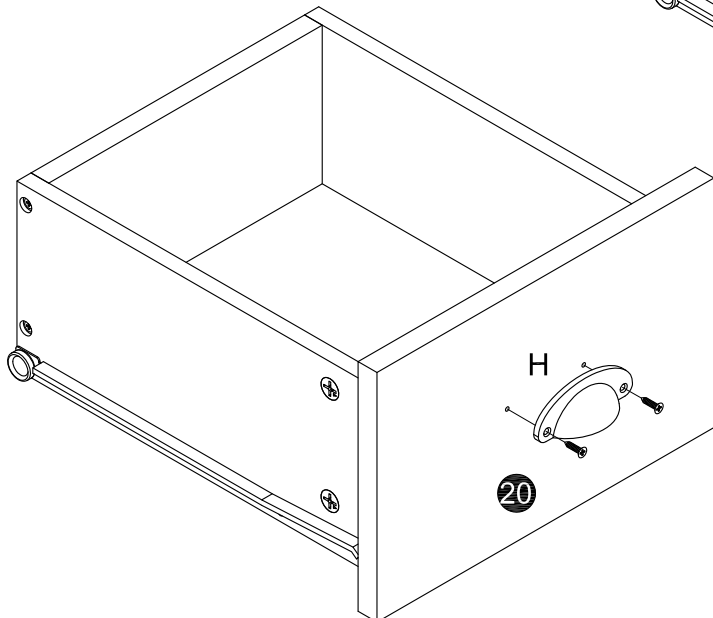

21

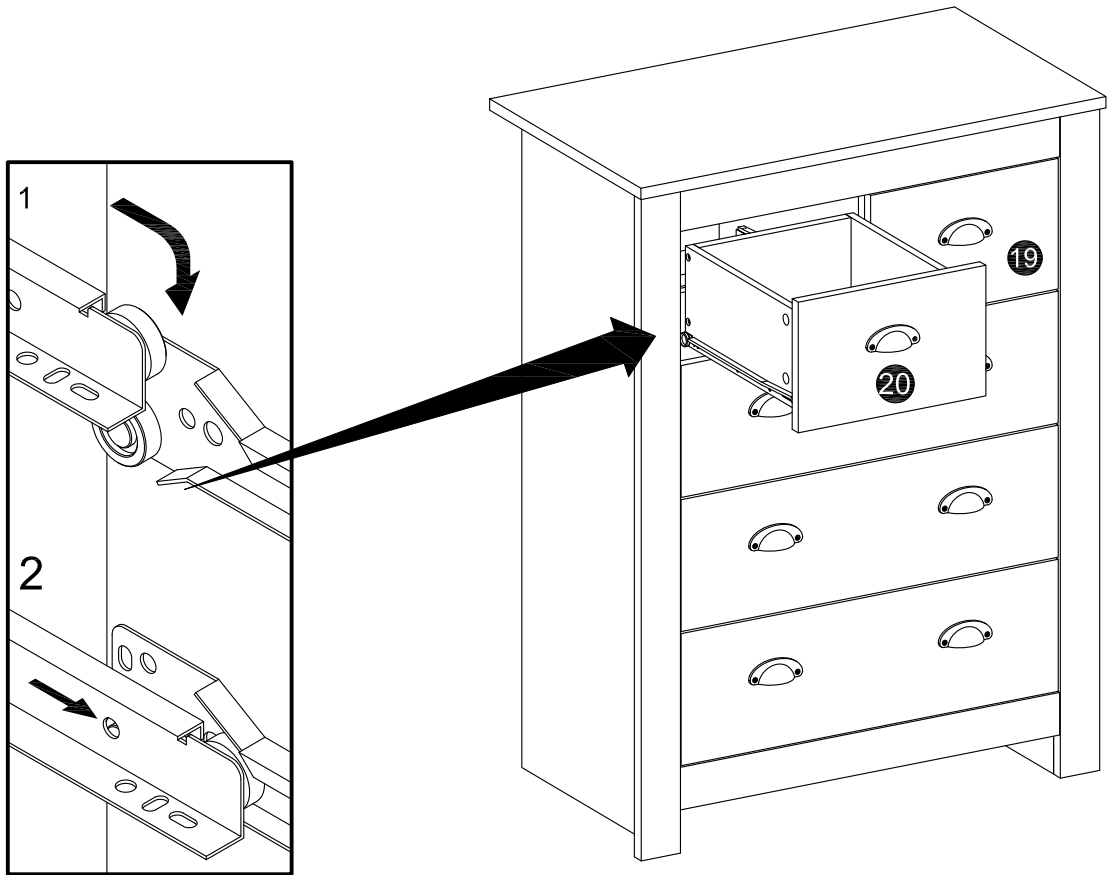

22

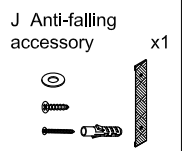
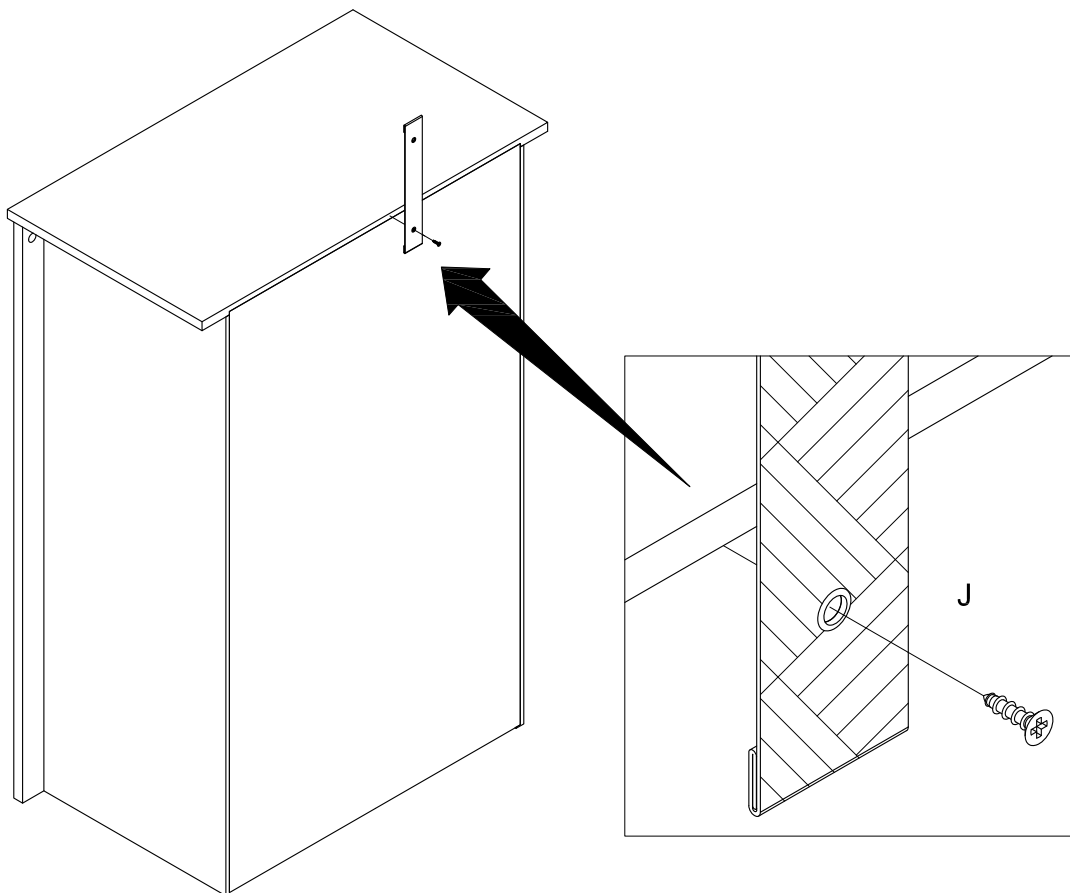

23

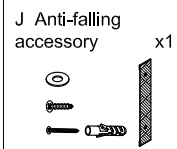
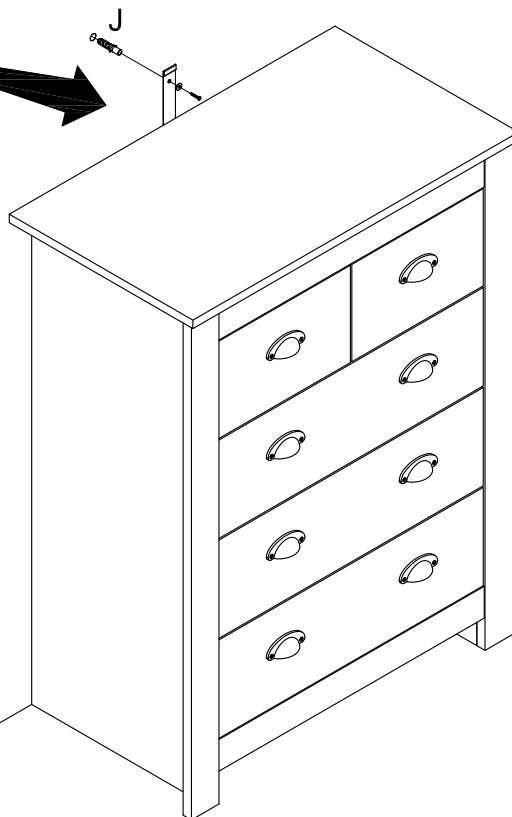
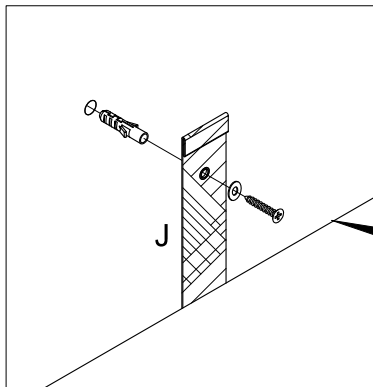

### CARE AND SAFETY GUIDELINES

Never use scourers, abrasives or chemical cleaners.

To clean, wipe with a damp sponge and warm soapy water. Do not use solvent based cleaners or detergents as they can bleach or damage the product.