

Pure & Easy



# ASSEMBLY INSTRUCTIONS

# NOTICE

IMPORTANT, RETAIN FOR FUTURE REFERENCE: READ CAREFULLY  
WICHTIG, FÜR SPÄTERE NACHSCHLAGE AUFBEWAHREN: SORGFÄLTIG LESEN  
IMPORTANTE, GUARDAR PARA REFERENCIA FUTURA: LEER ATENTAMENTE  
IMPORTANTE, CONSERVARE PER RIFERIMENTI FUTURI: LEGGERE ATTENTAMENTE  
IMPORTANT, À CONSERVER POUR RÉFÉRENCE FUTURE : LIRE ATTENTIVEMENT

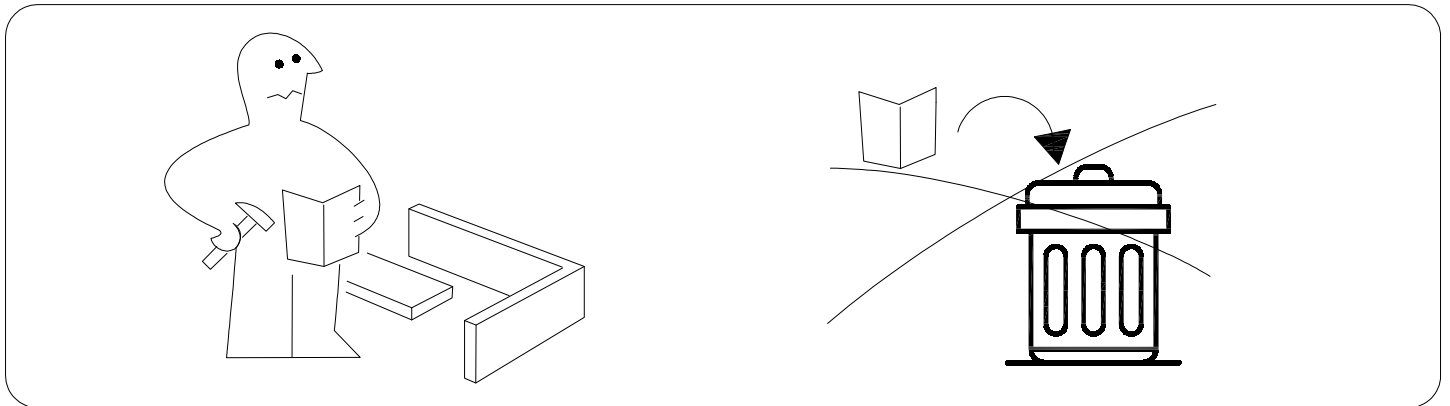

Assemble on a flat, clean and soft surface.  
Auf einer flachen, sauberen und weichen Oberfläche zusammenbauen.  
Assembler sur une surface plate, propre et douce.  
Assemblare su una superficie piatta, pulita e morbida.  
Ensamblar sobre una superficie plana, limpia y suave.

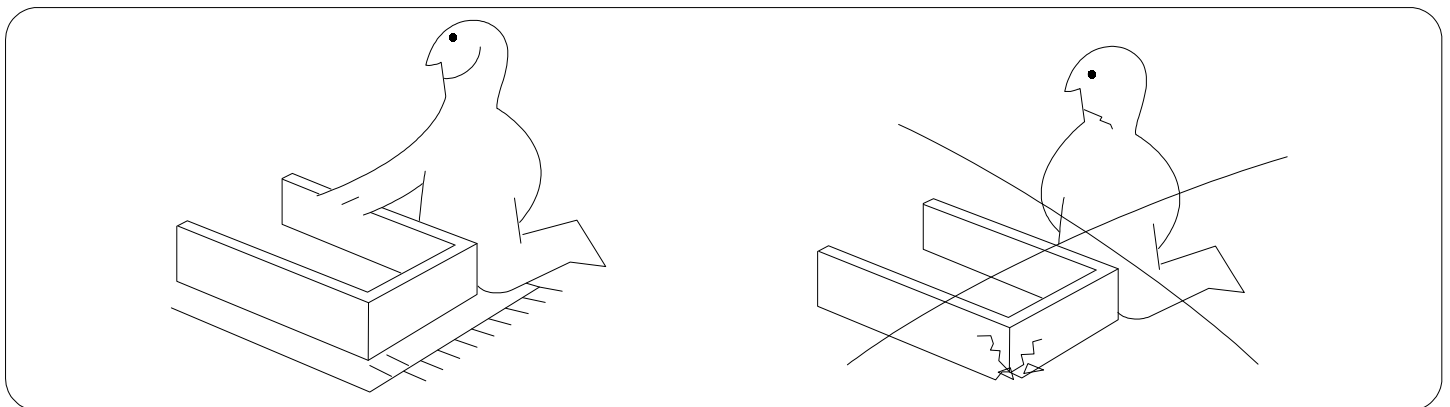

Professional installation is highly recommended.  
Eine professionelle Installation wird dringend empfohlen.  
Une installation professionnelle est fortement recommandée.  
Si raccomanda vivamente l'installazione professionale.  
Se recomienda altamente la instalación profesional.

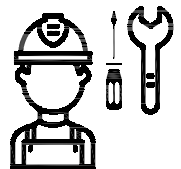

Periodically Check That All Components Are Tightly Secured.  
Überprüfen Sie Regelmäßig, Dass Alle Komponenten Fest Gesichert Sind.  
Vérifiez Périodiquement Que Tous Les Composants Sont Bien Fixés.  
Controllare Periodicamente Che Tutti I Componenti Siano Ben Fissati.  
Verifique Periódicamente Que Todos Los Componentes Estén Bien Asegurados.

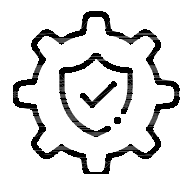

It is recommended that multiple people assemble this product.  
 Es wird empfohlen, dass mehrere Personen dieses Produkt zusammenbauen.  
 Il est recommandé que plusieurs personnes assemblent ce produit.  
 Si raccomanda che più persone assemblino questo prodotto.  
 Se recomienda que varias personas ensamblen este producto.

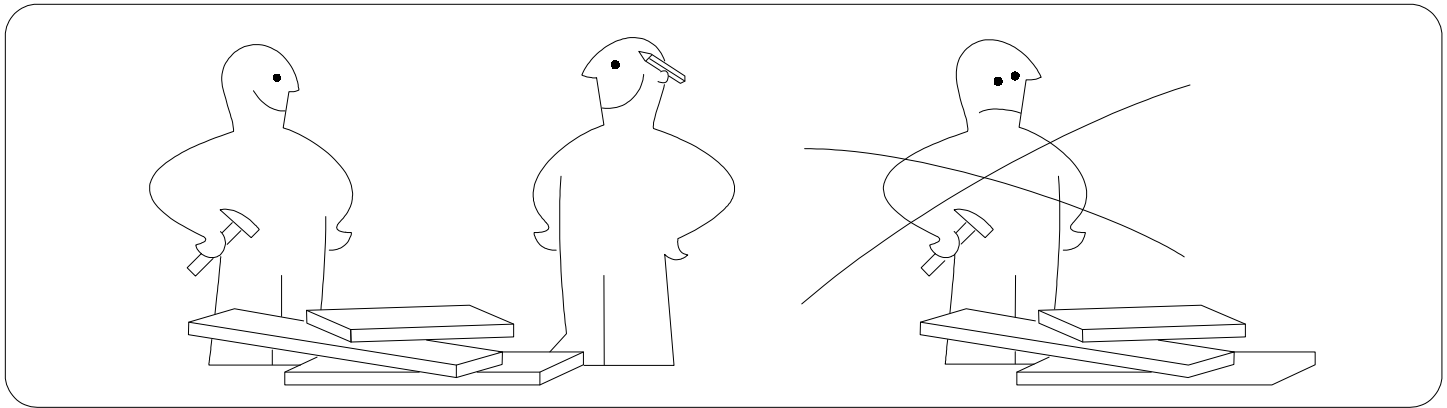

Serious or fatal crushing injuries can occur from furniture tip-over. Always secure this furniture to the wall using tip-over restraints.

Schwere oder tödliche Quetschverletzungen können durch das Umkippen von Möbeln verursacht werden. Sichern Sie diese Möbel immer mit Kipp-Sicherungen an der Wand.

Des blessures graves ou mortelles par écrasement peuvent survenir en cas de basculement de meubles. Fixez toujours ces meubles au mur à l'aide de dispositifs anti-basculement.

Lesioni gravi o mortali da schiacciamento possono verificarsi a causa del ribaltamento dei mobili. Fissare sempre questi mobili alla parete utilizzando i sistemi di blocco anti-ribaltamento.

Pueden ocurrir lesiones graves o fatales por aplastamiento debido al volcamiento de muebles. Siempre asegure este mueble a la pared utilizando dispositivos anti-vuelco.

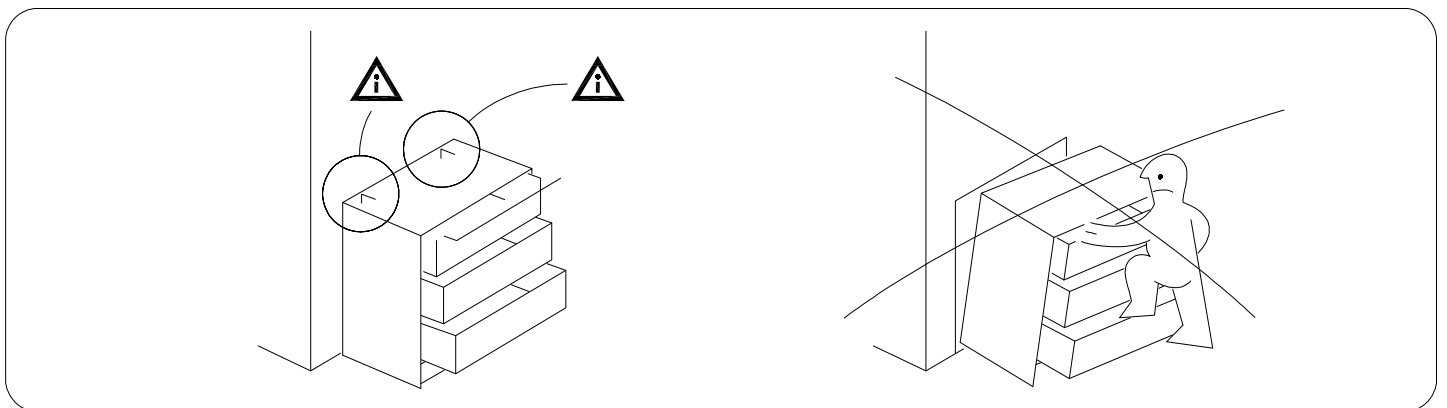

Please have the following auxiliary tools ready:

Bitte haben Sie die folgenden Hilfswerkzeuge bereit:

Veillez avoir les outils auxiliaires suivants à portée de main:

Si prega di avere pronti i seguenti strumenti ausiliari:

Por favor, tenga listos las siguientes herramientas auxiliares:

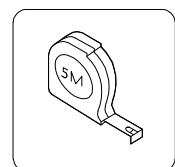
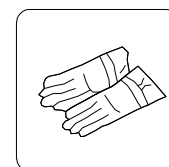
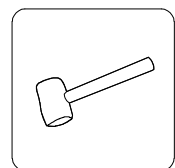
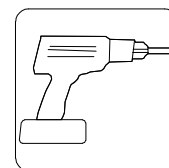

# EN

## Use the Cam Lock and Eccentric Wheel ECCENTRIC WHEEL

Tighten the bolt until the shoulder is aligned with the panel.  
Be sure not to tighten too much or too little.

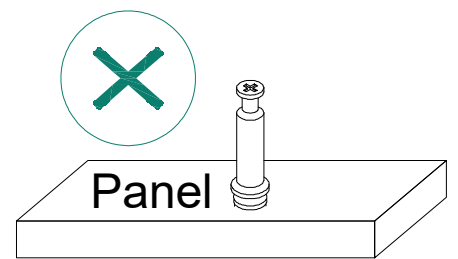
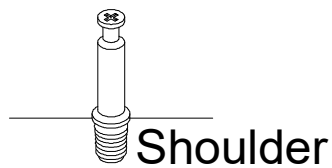
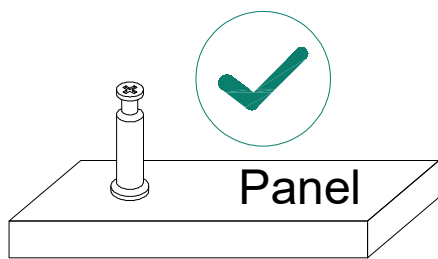

The pre-inserted nut should align with the center of the cam lock when joining two panels. The cam lock should be inserted before the eccentric wheel.

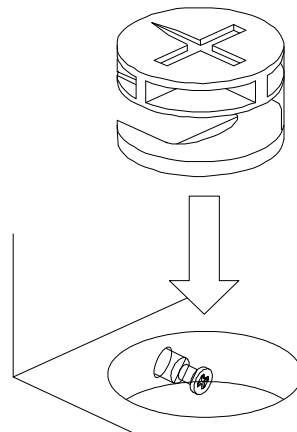

Turn the cam lock clockwise to tighten.

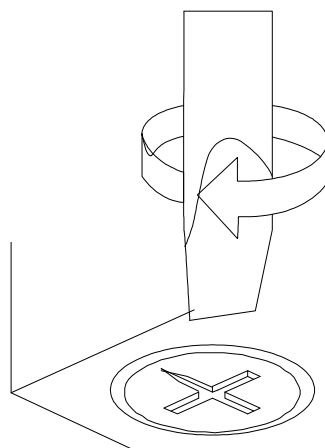

**DE**

## Verwenden Sie das Nockenschloss und das Exzenterrad ECCENTRIC WHEEL

Ziehen Sie die Schraube fest, bis die Schulter mit der Platte ausgerichtet ist.  
Achten Sie darauf, nicht zu viel oder zu wenig festzuziehen.

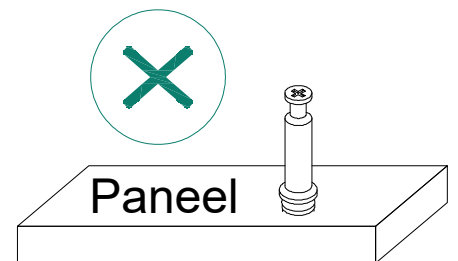
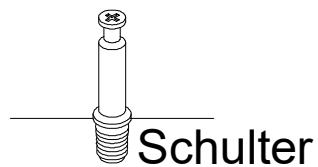
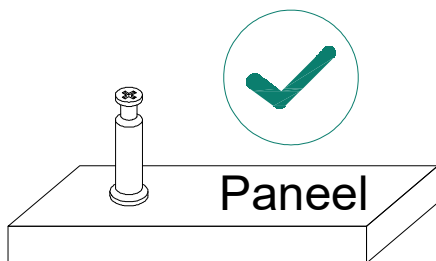

Die vorab eingesetzte Mutter sollte beim Verbinden zweier Paneele mit der Mitte des Nockenschlosses ausgerichtet sein. Die Nockenverriegelung sollte vor dem Exzenterrad eingesetzt werden.

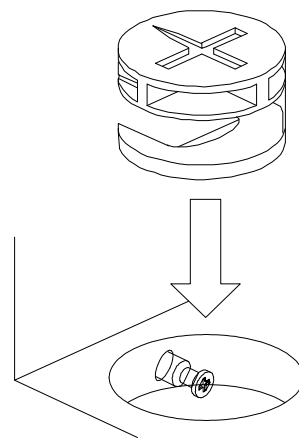

Drehen Sie die Nockenverriegelung zum Festziehen im Uhrzeigersinn.

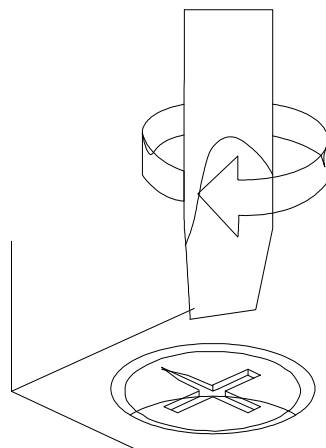

**FR**

## Utilisez le verrou à came et la roue excentrique

### ROUE EXCENTRIQUE

Serrez le boulon jusqu'à ce que l'épaule soit alignée avec le panneau.  
Assurez-vous de ne pas trop serrer ou sous-serrer.

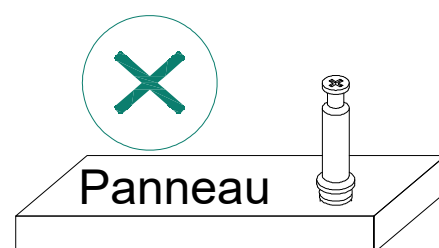
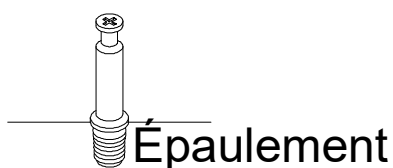
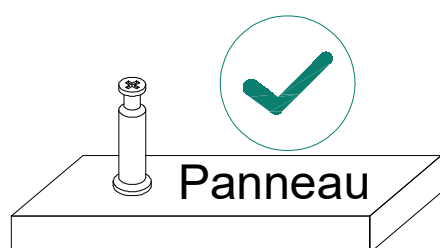

écrou pré-inséré doit s'aligner avec le centre du verrou à came en joignant deux panneaux. Le verrou à came doit être insérée avant la roue excentrique.

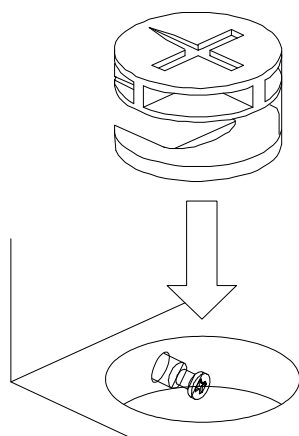

Tournez le verrou à came dans le sens des aiguilles d'une montre pour serrer.

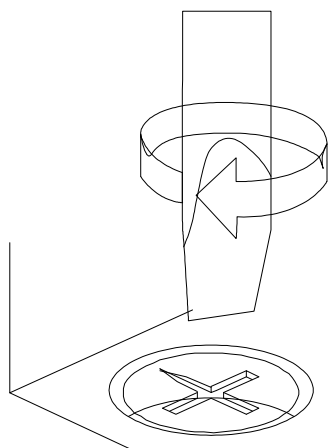

IT

## Usare il Blocco Cam e la Ruota Eccentrica

### RUOTA ECCENTRICA

Stringere il bullone fino a quando la spalla è allineata con il pannello.

Fare attenzione a non stringere troppo o troppo poco .

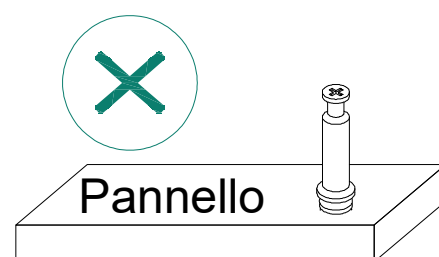
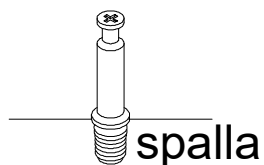
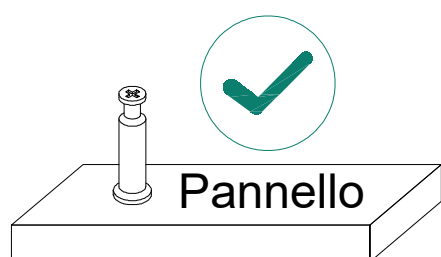

Il dado pre-inserito deve essere allineato con il centro del blocco cam quando i due pannelli sono allineati. Il blocco cam deve essere inserito prima della ruota eccentrica.

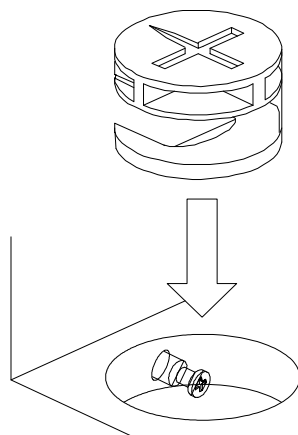

Girare in senso orario il blocco cam per stringerlo.

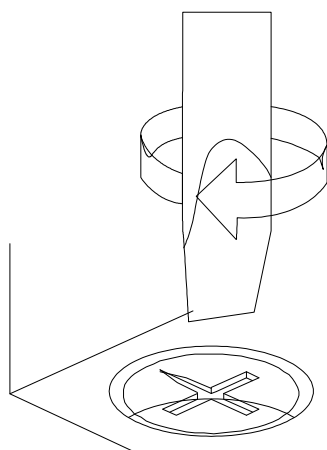

# ES

## Utilice el cerrojo y la rueda excéntrica

### RUEDA ECCÉNTRICA

Apriete el perno hasta que el cuello esté alineado con el panel.  
Asegúrese de no apretar demasiado ni muy poco.

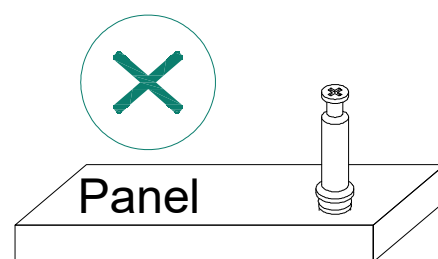
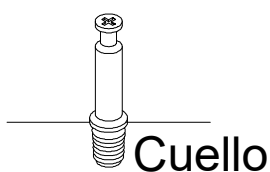
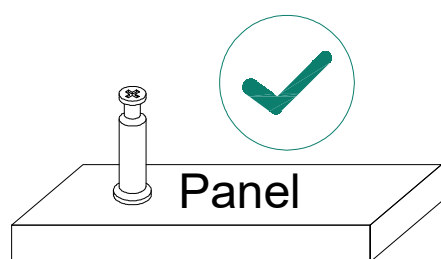



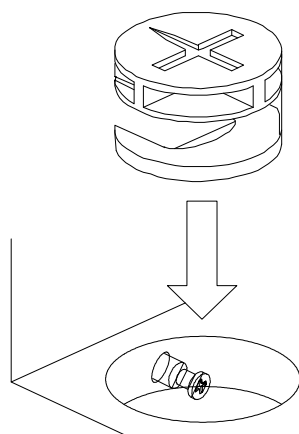

La tuerca preinsertada debe alinearse con el centro del cerrojo al unir dos paneles.  
El cerrojo debe insertarse antes de la rueda excéntrica.

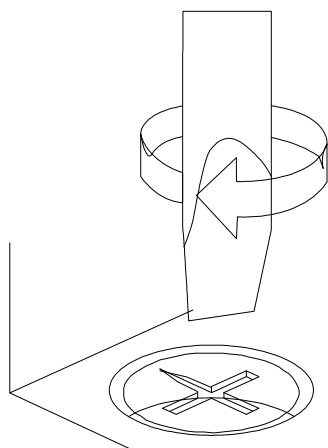



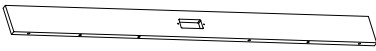
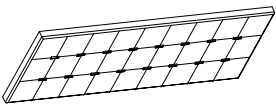
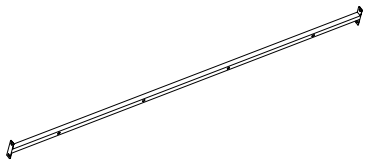
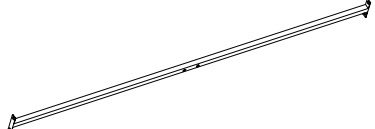

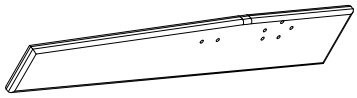
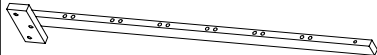
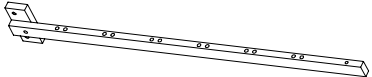
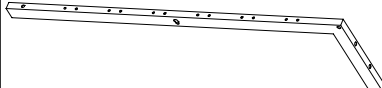
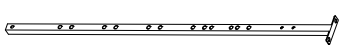
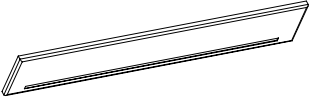
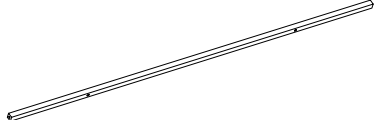
Gire el cerrojo en sentido horario para ajustarlo.





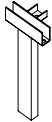
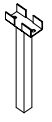
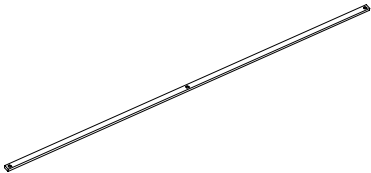

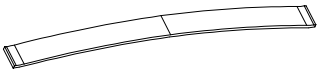
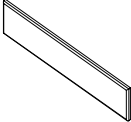
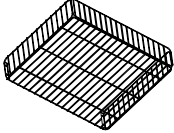





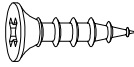

# PARTS

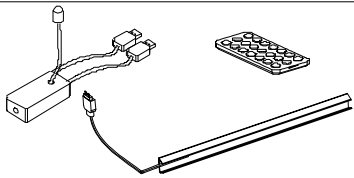
| Item no.<br>Nr .<br>N °d article<br>Articolo No.<br>Artículo No | Reference Image<br>Referenzbild<br>Image de référence<br>Immagine di riferimento<br>Imagen.de referencia | Qty<br>Menge<br>Qté.<br>Qtà<br>Cant. | Item no.<br>Nr .<br>N °d article<br>Articolo No.<br>Artículo No | Reference Image<br>Referenzbild<br>Image de référence<br>Immagine di riferimento<br>Imagen.de referencia | Qty<br>Menge<br>Qté.<br>Qtà<br>Cant. |
|---|--|--------------------------------------|---|--|--------------------------------------|
| 1   |                         | X1                                   | 2   |                        | X1                                   |
| 3   |                         | X1                                   | 4   |                        | X1                                   |
| 5   |                        | X1                                   | 6   |                       | X1                                   |
| 7   |                       | X1                                   | 8   |                      | X1                                   |
| 9   |                       | X1                                   | 10  |                      | X2                                   |
| 11  |                       | X1                                   | 12  |                      | X1                                   |
| 13  |                       | X1                                   | 14  |                      | X1                                   |

# PARTS

| Item no.<br>Nr .<br>N °d article<br>Articolo No.<br>Artículo No | Reference Image<br>Referenzbild<br>Image de référence<br>Immagine di riferimento<br>Imagen de referencia | Qty<br>Menge<br>Qté.<br>Qtà<br>Cant. | Item no.<br>Nr .<br>N °d article<br>Articolo No.<br>Artículo No | Reference Image<br>Referenzbild<br>Image de référence<br>Immagine di riferimento<br>Imagen de referencia | Qty<br>Menge<br>Qté.<br>Qtà<br>Cant. |
|---|--|--------------------------------------|---|--|--------------------------------------|
| 15  |                         | X2                                   | 16  |                       | X3                                   |
| 17  |                         | X1                                   | 18  |                       | X24                                  |
| 19  |                        | X12                                  | 20  |                       | X24                                  |
| 21  |                       | X4                                   | 22  |                     | X4                                   |
| 23  |                       | X16                                  |   |  |                                      |

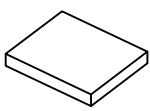
# PARTS

| Item no.<br>Nr<br>N °d article<br>Articolo No.<br>Artículo No | Reference Image<br>Referenzbild<br>Image de référence<br>Immagine di riferimento<br>Imagen de referencia | Qty<br>Menge<br>Qté.<br>Qtà<br>Cant. | Item no.<br>Nr<br>N °d article<br>Articolo No.<br>Artículo No | Reference Image<br>Referenzbild<br>Image de référence<br>Immagine di riferimento<br>Imagen de referencia | Qty<br>Menge<br>Qté.<br>Qtà<br>Cant. |
|---|--|--------------------------------------|---|--|--------------------------------------|
| A   | <br>M3.5 X 14mm         | X4                                   | I   |                       | X18                                  |
| B   | <br>M8 X 15mm           | X10                                  | J   |                       | X1                                   |
| C   |                        | X1                                   | K   | <br>M6 X 15mm        | X24                                  |
| D   | <br>M8 X 35mm         | X23                                  | L   |                     | X8                                   |
| E   | <br>M8 X 55mm         | X10                                  | M   |                     | X4                                   |
| F   |                       | X8                                   |   |  |                                      |
| G   | <br>5#                | X1                                   |   |  |                                      |
| H   |                       | X18                                  |   |  |                                      |

# EXPLODED VIEW

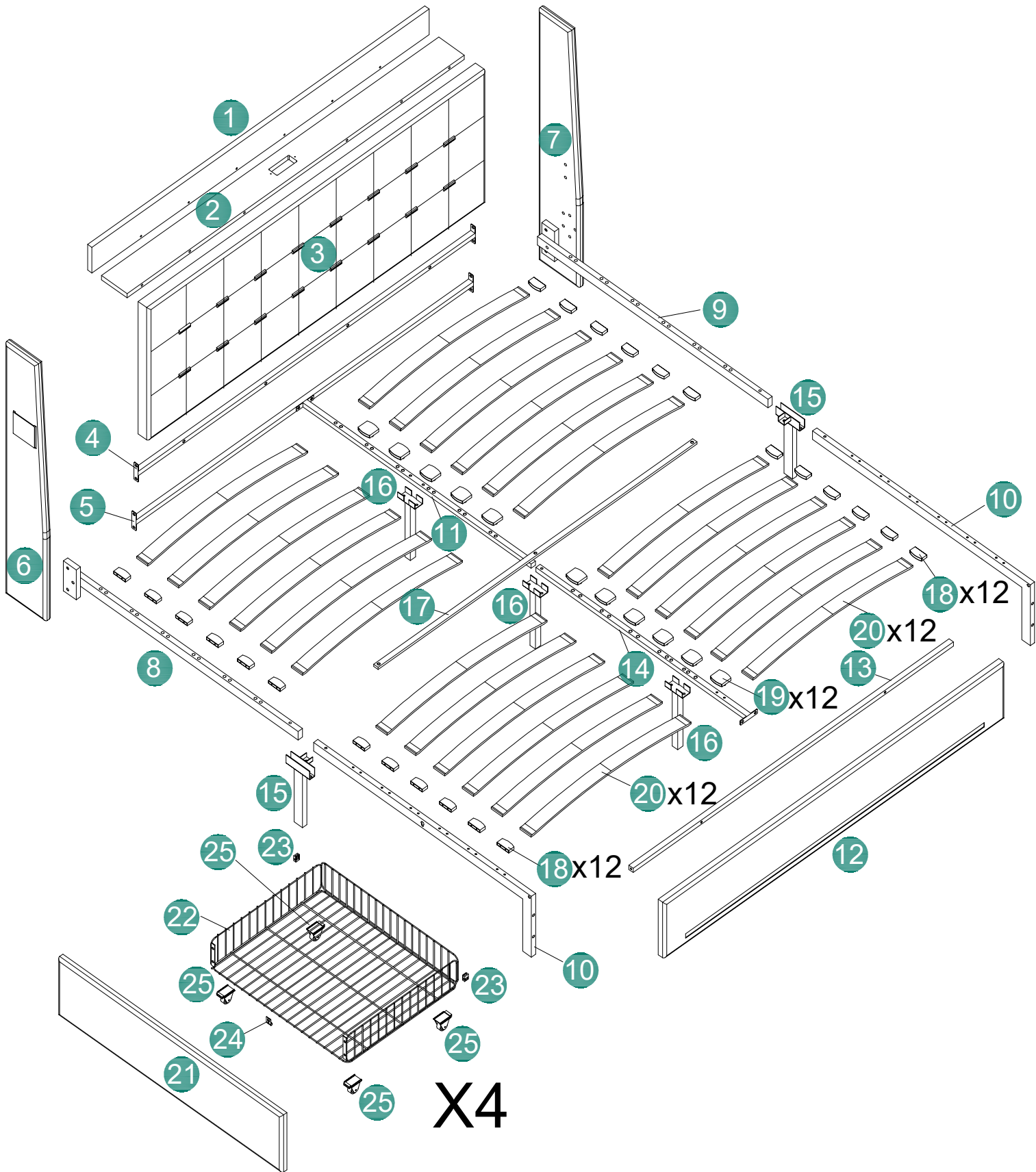

# ASSEMBLY

1



① 1pc

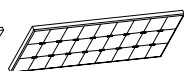

③ 1pc



Ⓜ 12pcs

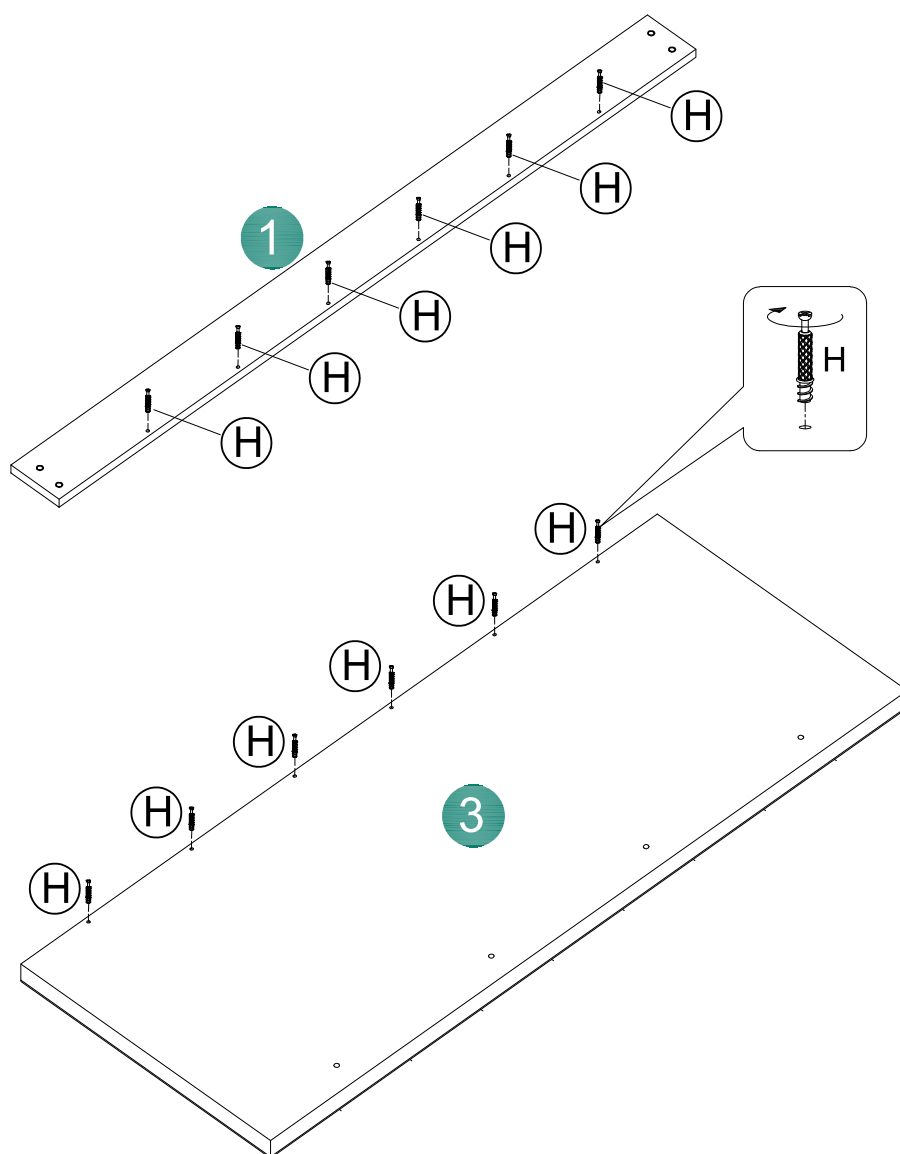
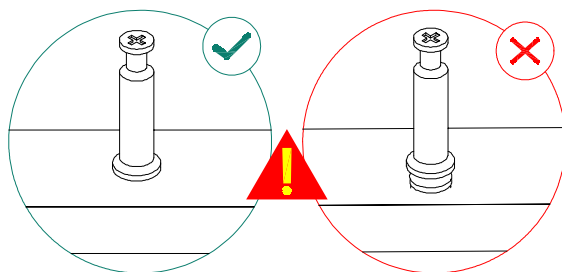

**2**



① 14pcs

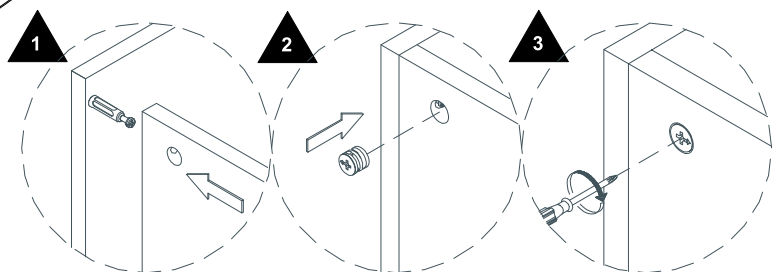
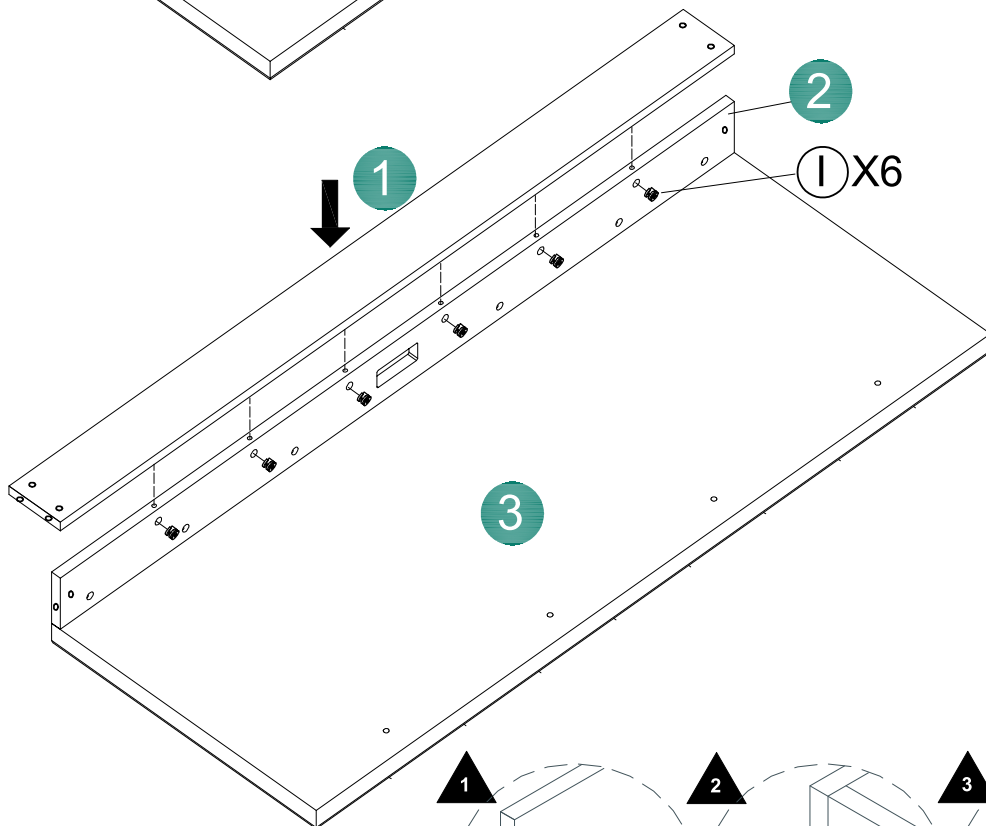
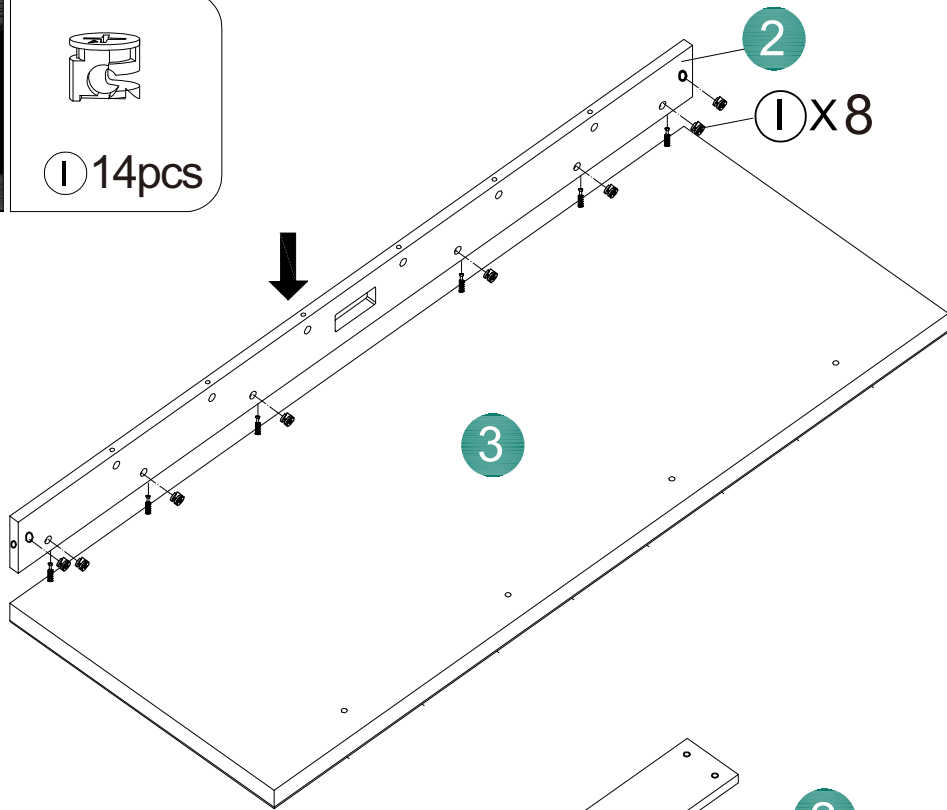

**3**

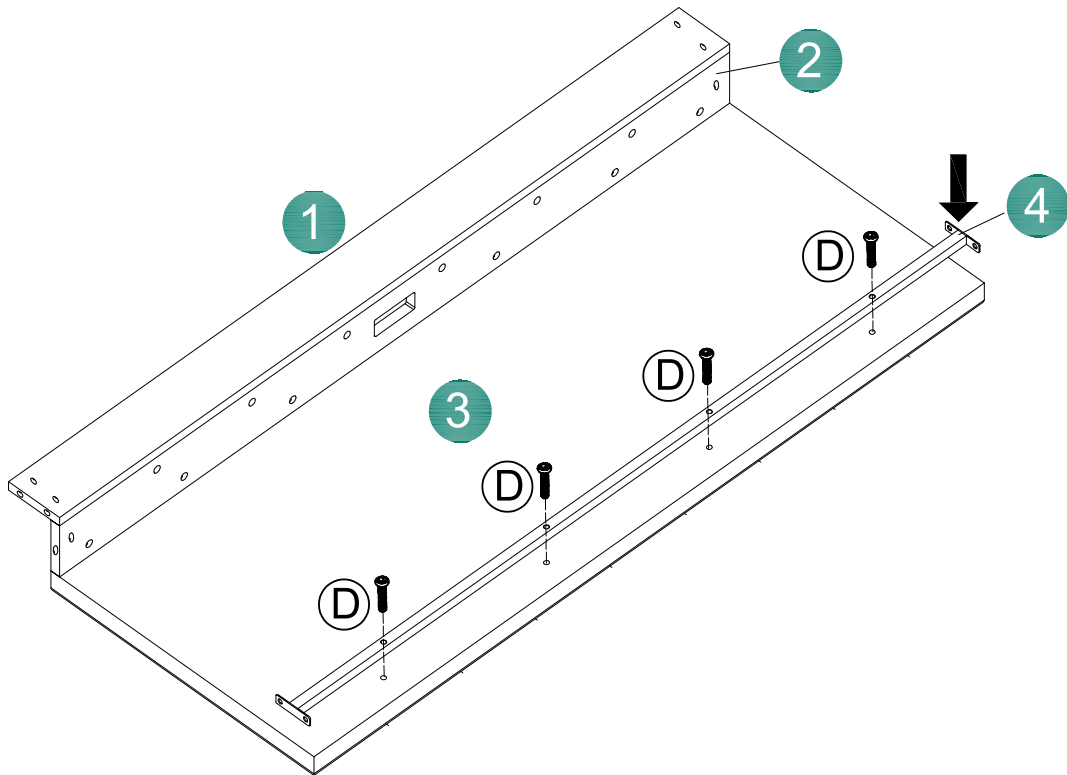
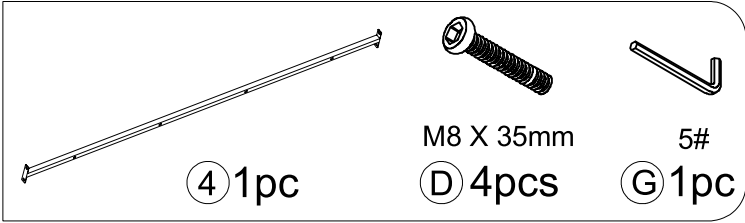

# 4

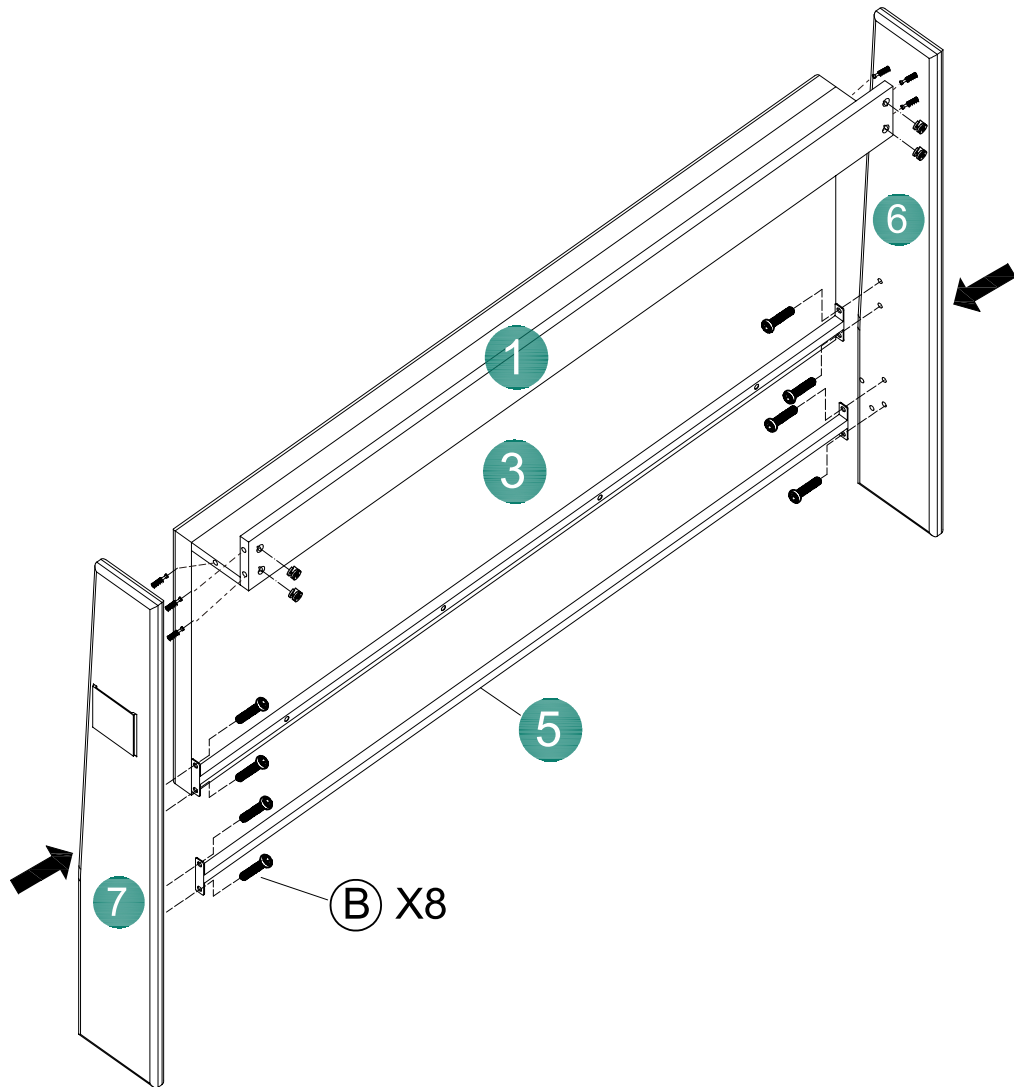
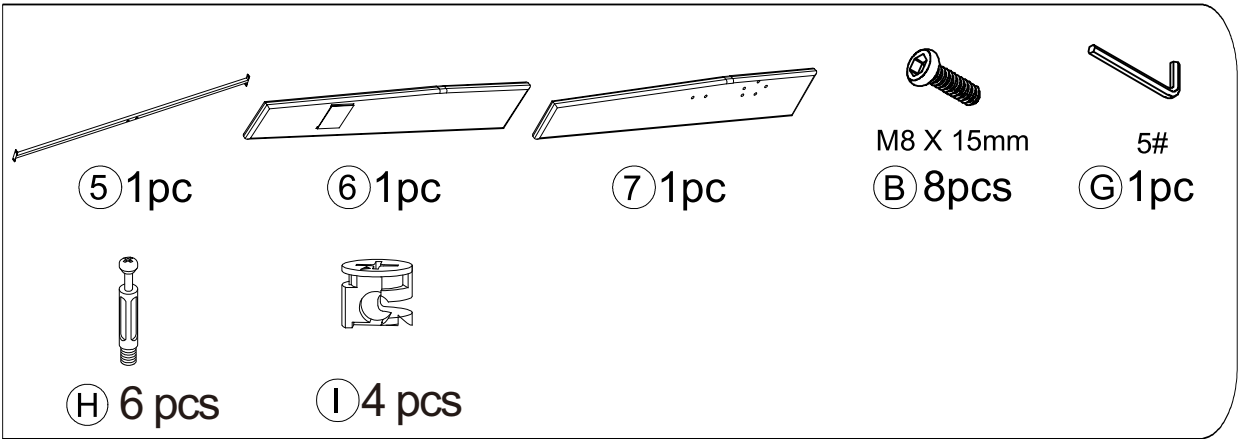

**5**

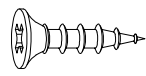

M3.5 X 14mm

Ⓐ 2pcs



Ⓝ 1pc

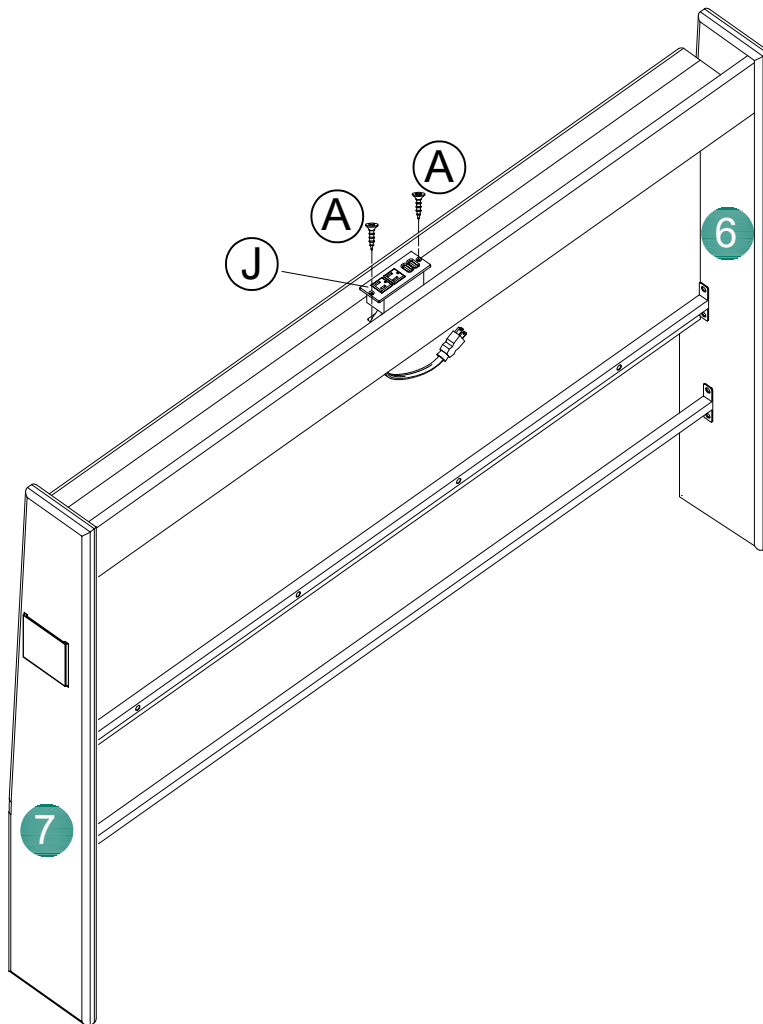

# 6

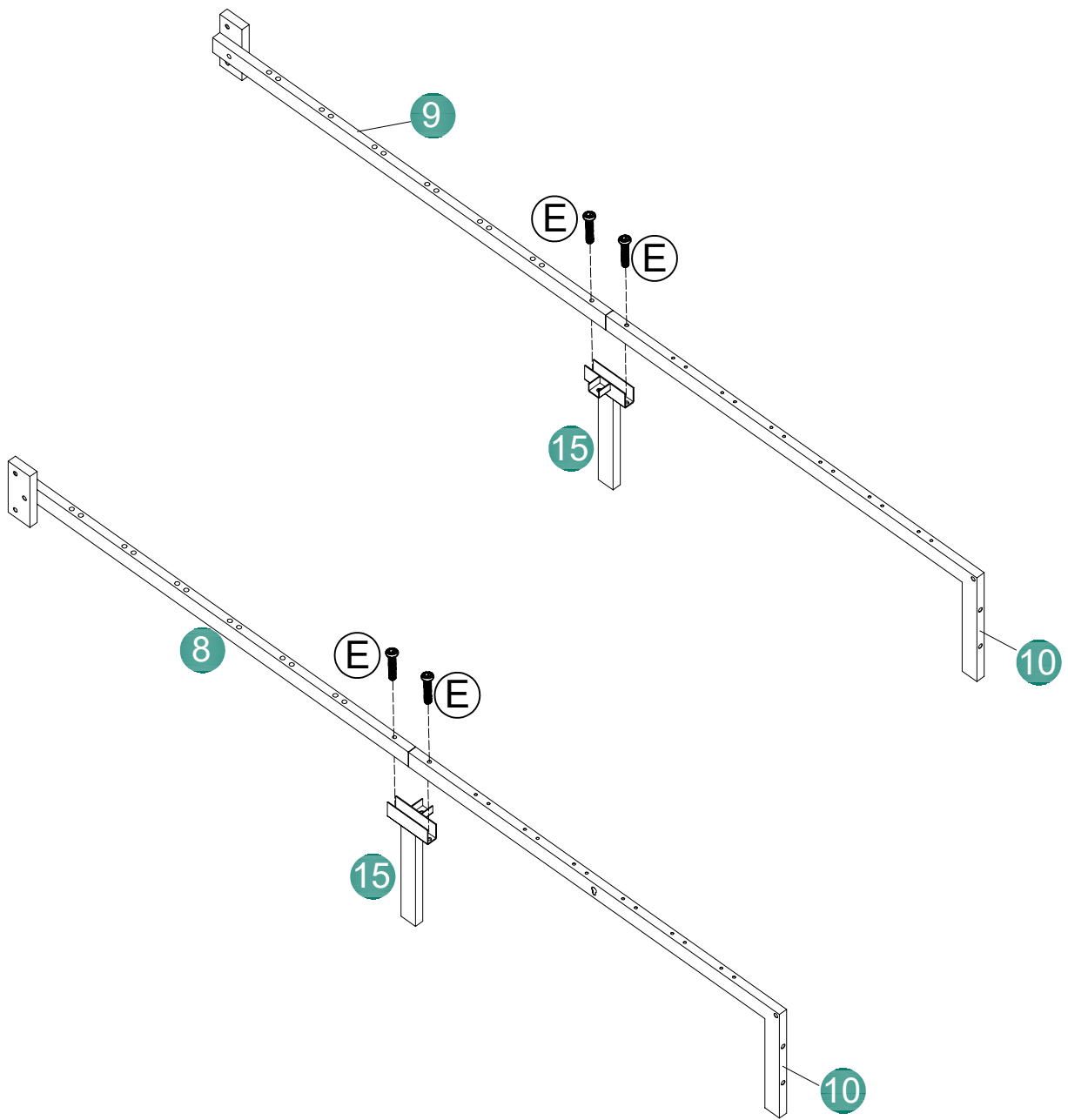
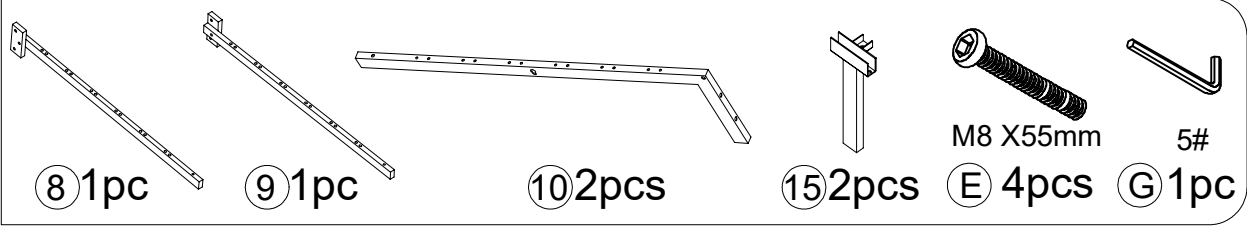

# 7

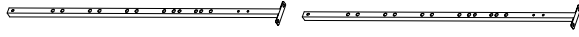

11pc

14pc

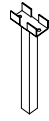

163pcs



M8 X 35mm  
D 6pcs



5#  
G 1pc

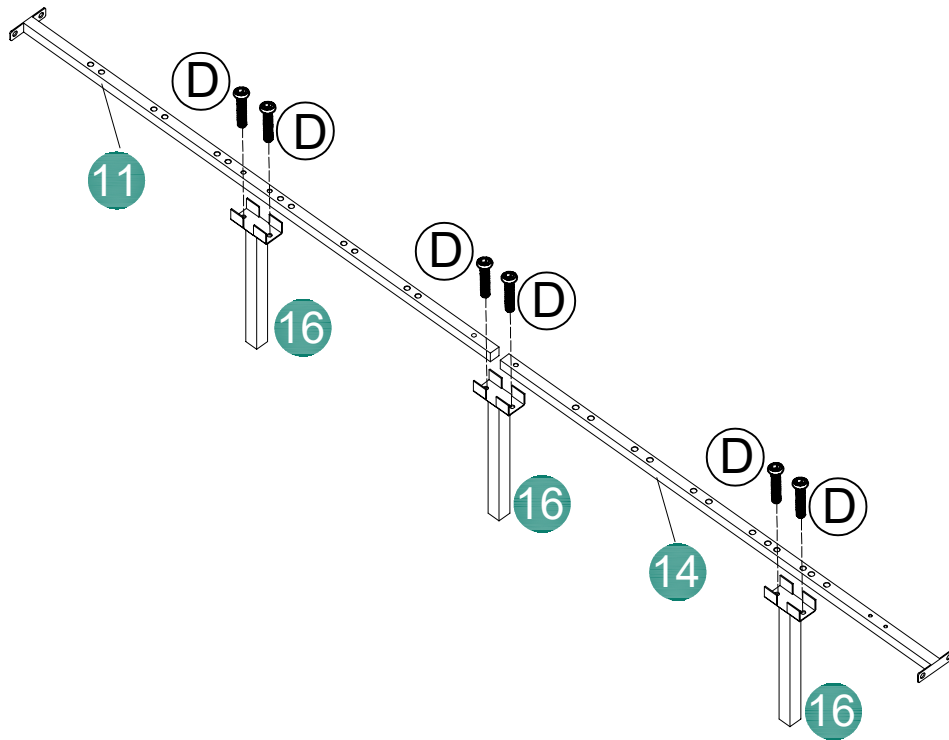

# 8

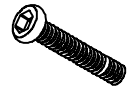
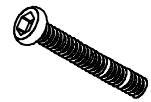
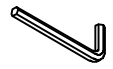
- |   |   |   |  |
|---|---|---|--|
|  |  |  |  |
| M8 X 15mm   | M8 X 35mm   | M8 X 55mm   | 5#   |
| (B) 2pcs  | (D) 7pcs  | (E) 2pcs  | (G) 1pc  |

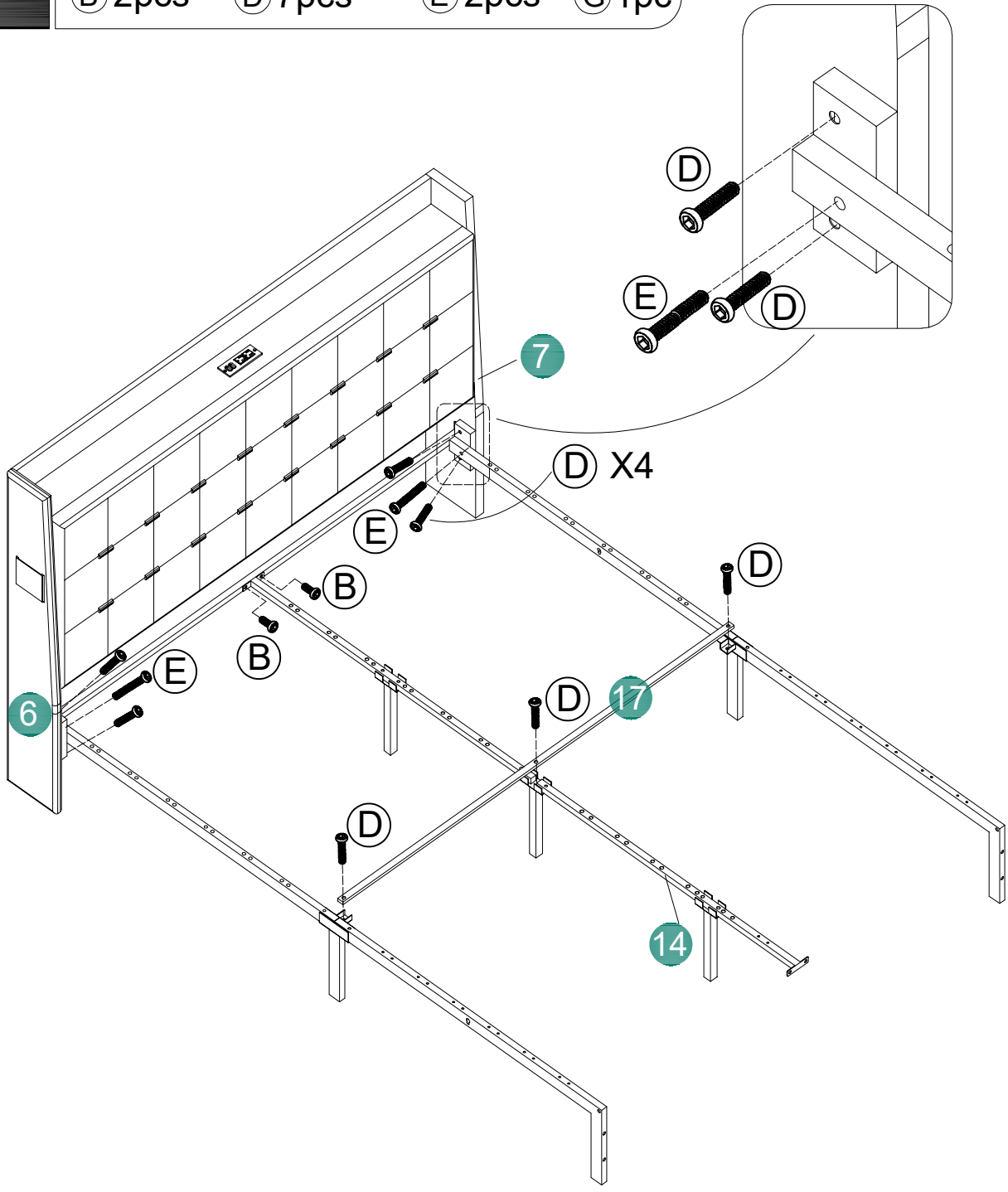

9



M8 X 35mm

ⓓ 2pcs



5#

ⓐ 1pc

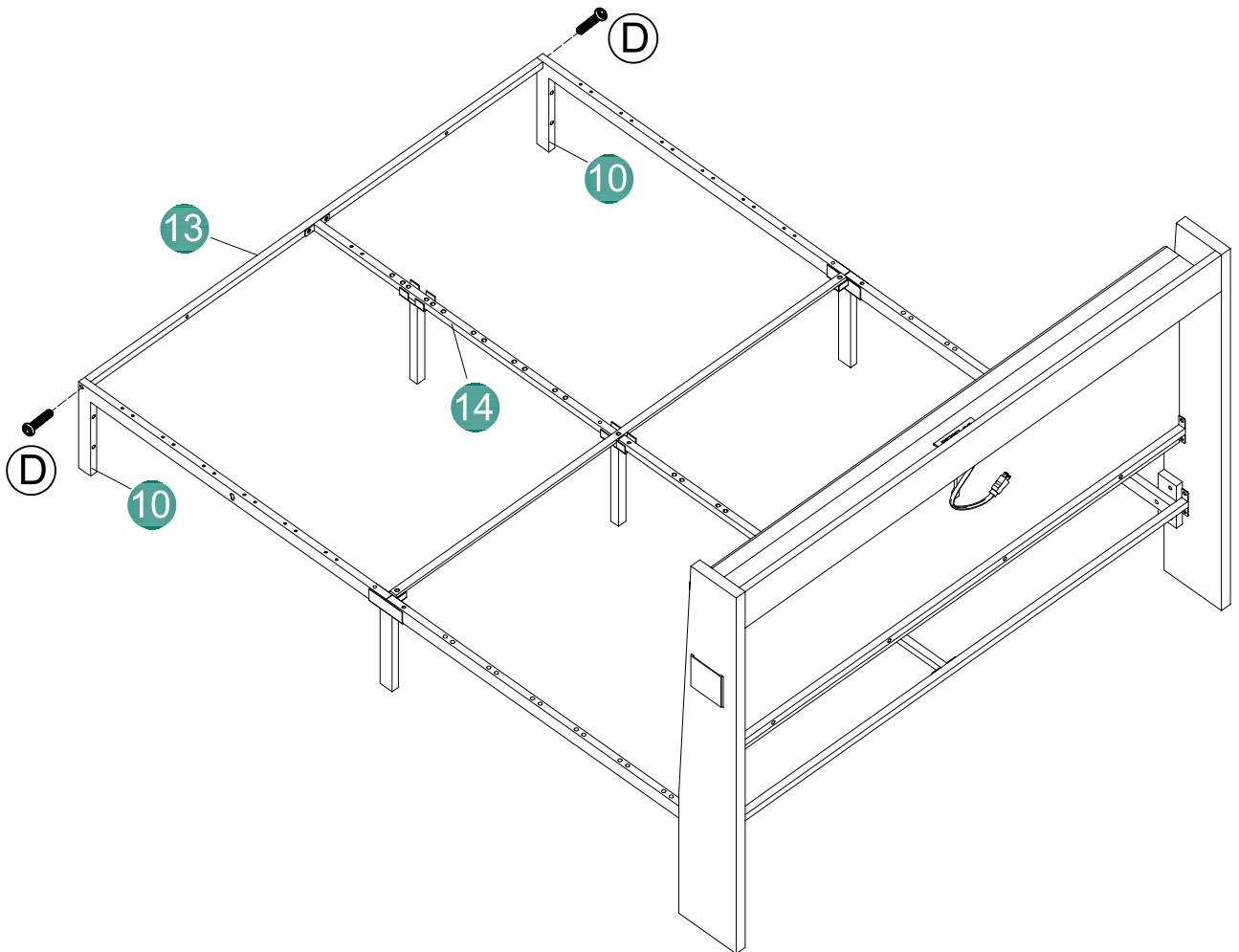

10

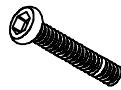

M8 X 35mm

(D) 4pcs

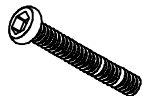

M8 X 55mm

(E) 4pcs

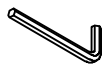

5#

(G) 1pc

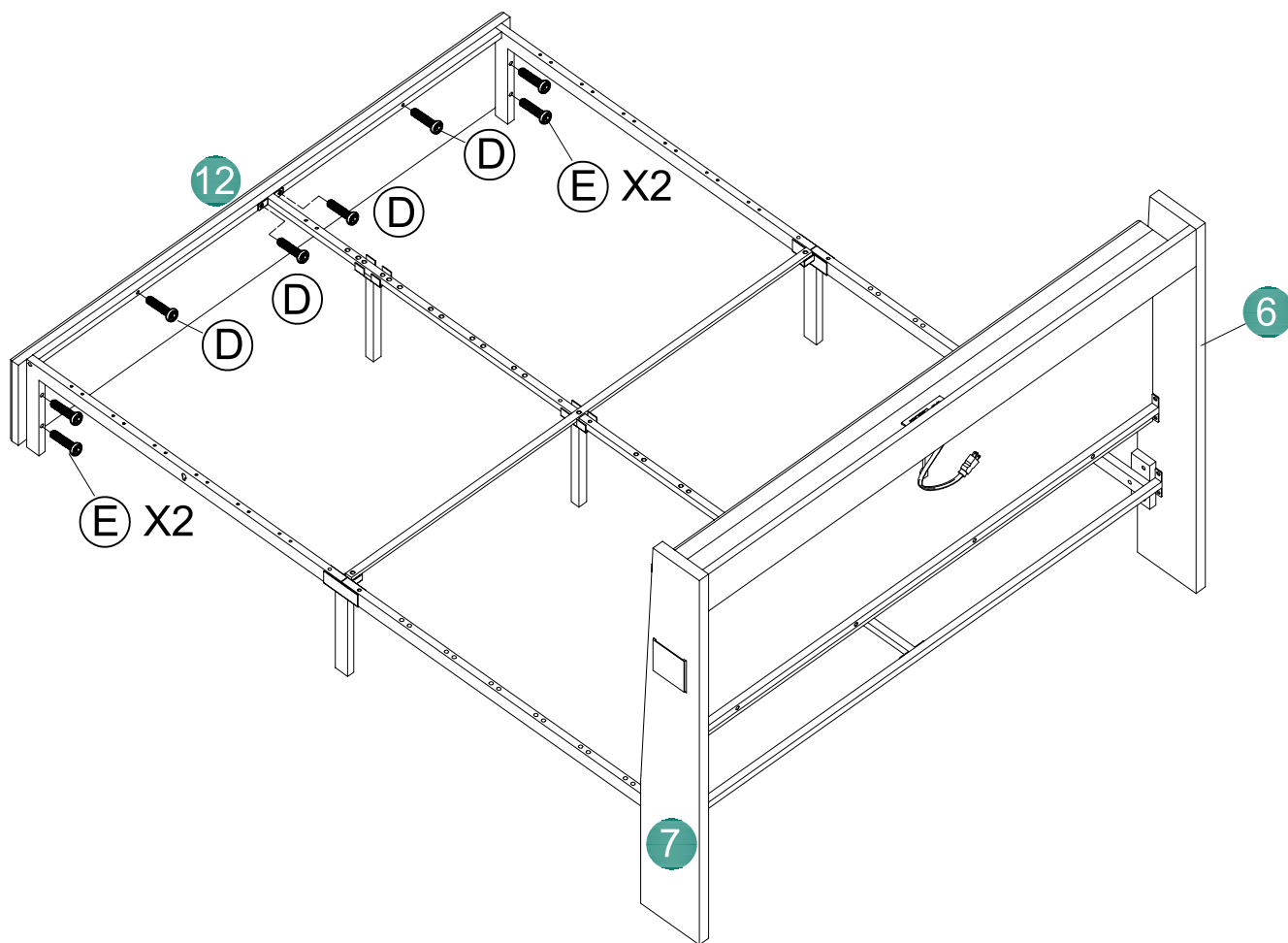

# 11

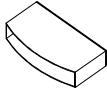

⑱ 24pcs

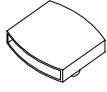

⑲ 12pcs

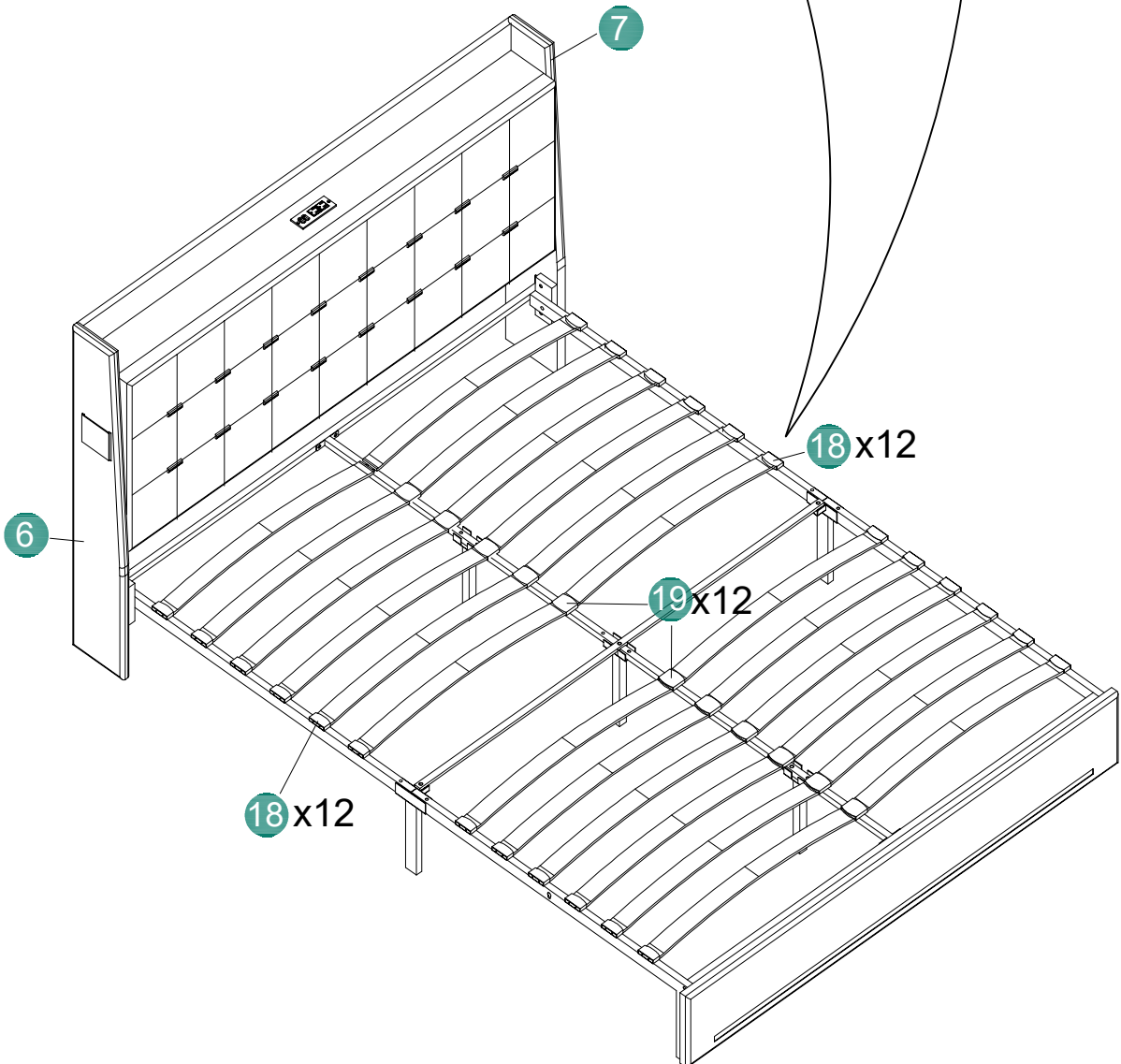
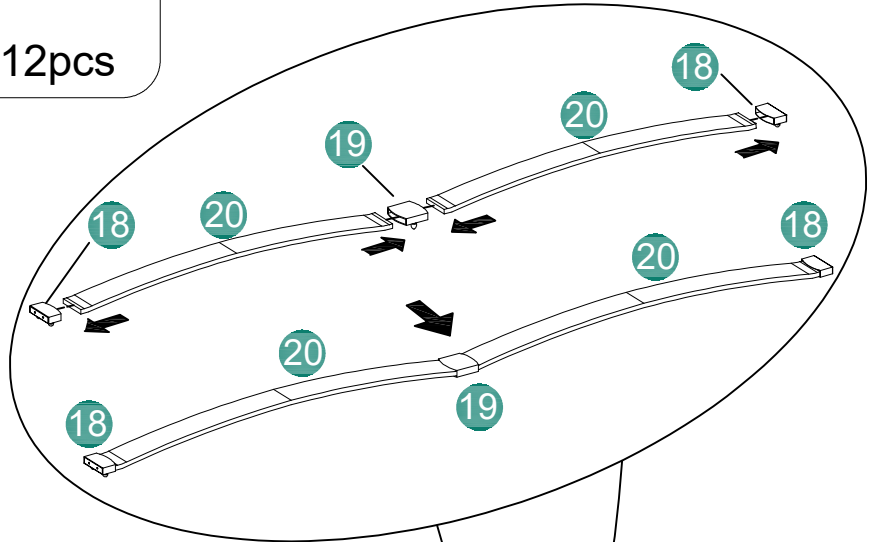

# 12



L 8pcs



M 4pcs



23 16pcs

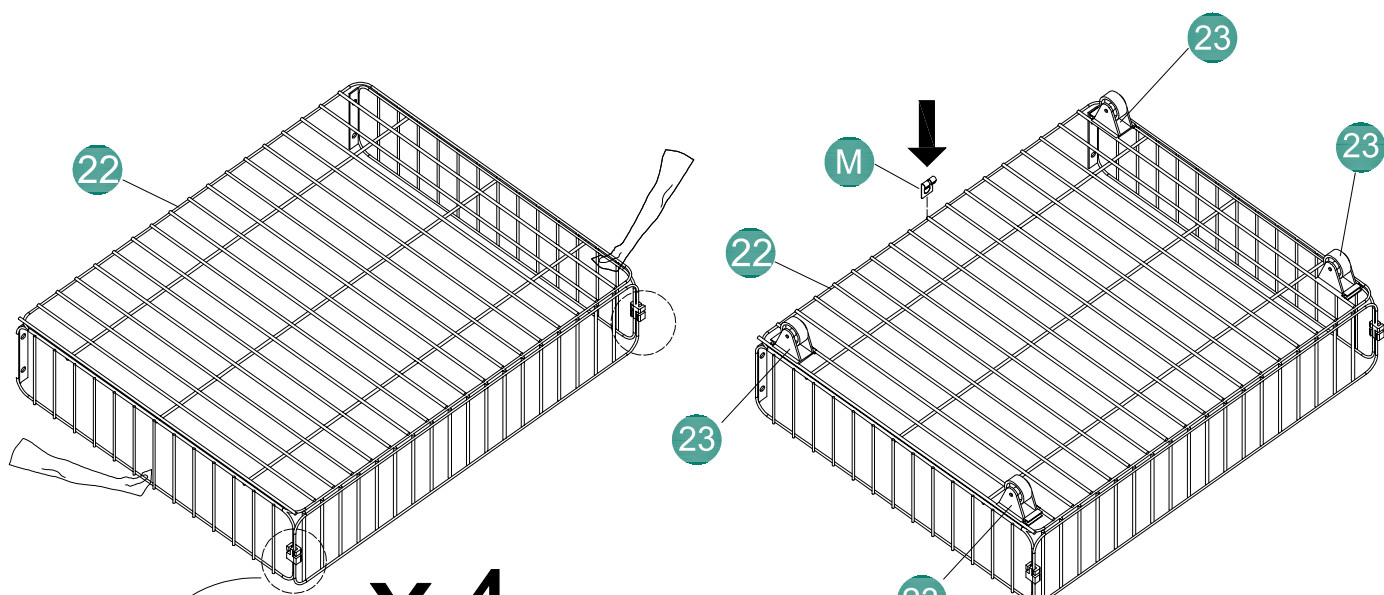

**X4**

**X4**

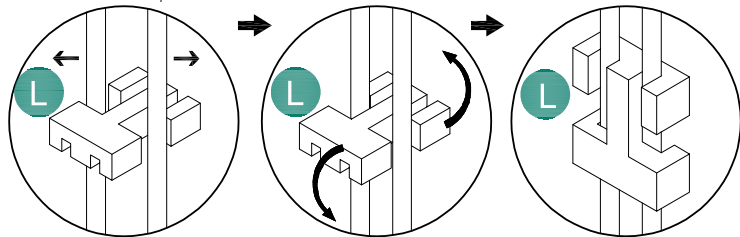

**13**



M6 X 15mm

(K) 24pcs

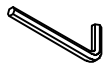

5#

(G) 1pc

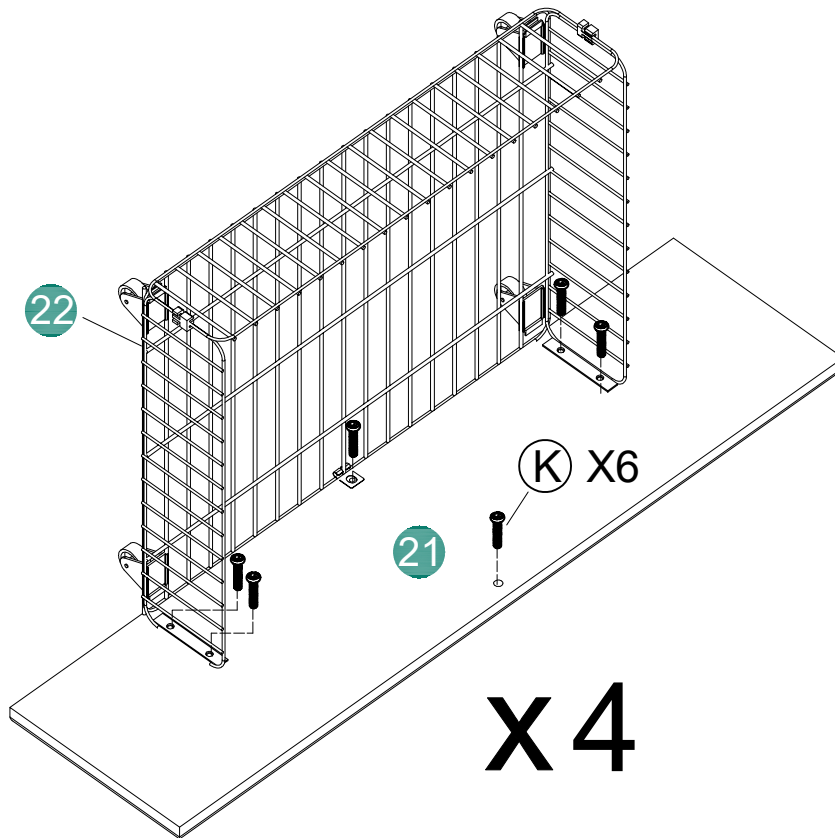

# 14

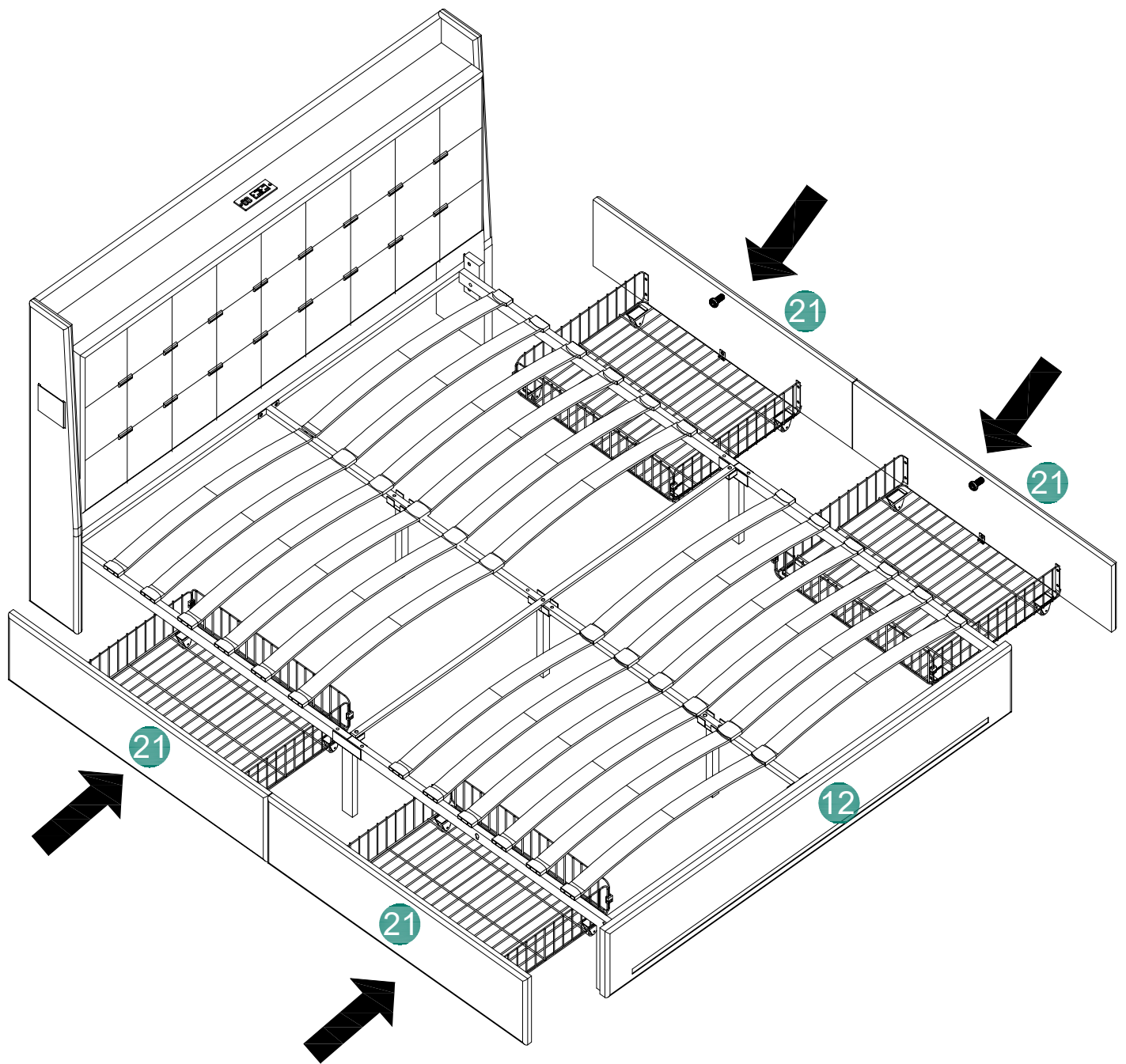

# 15

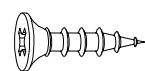

M3.5 X 14mm

(A) 2pcs

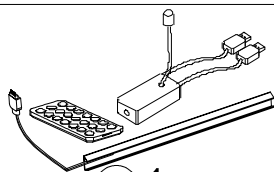

(C) 1pc

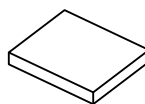

(F) 8pcs

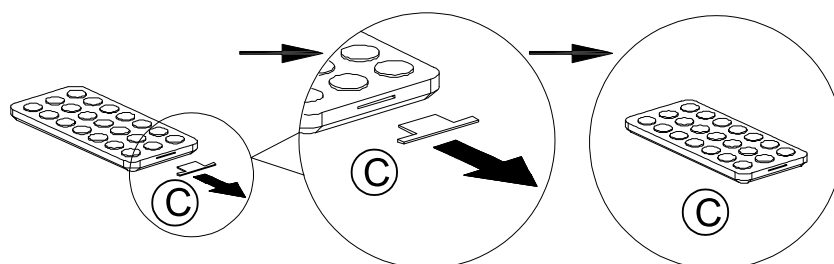
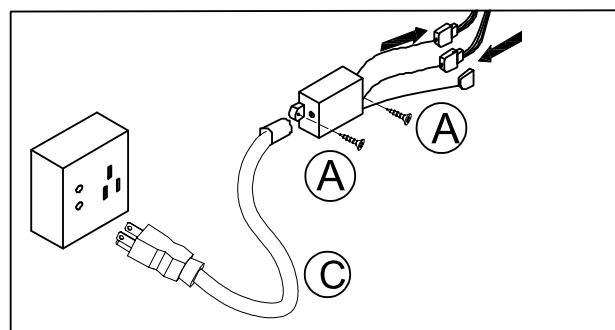
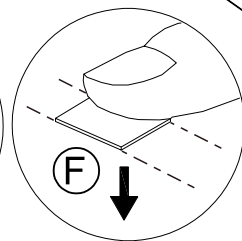
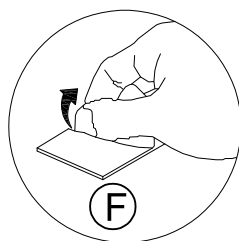
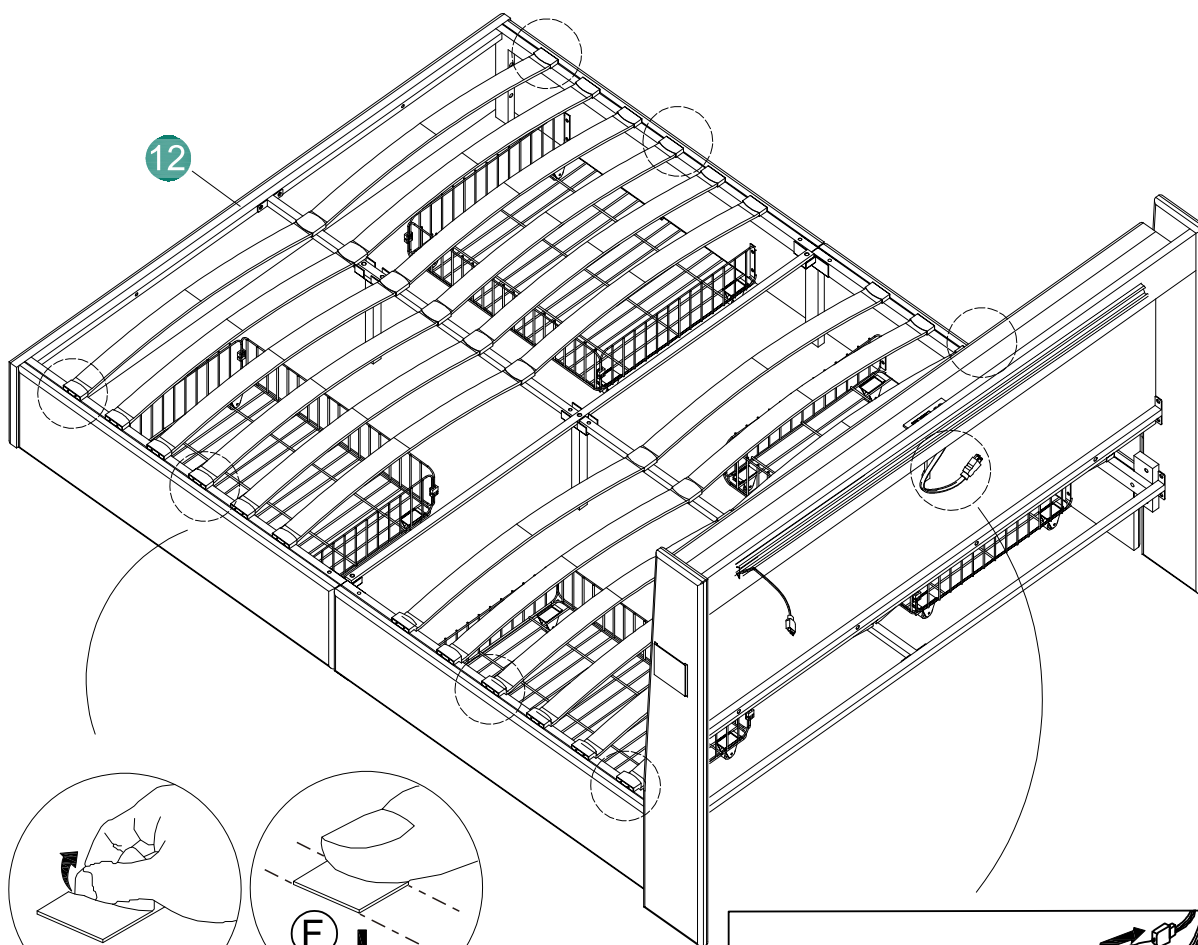

16

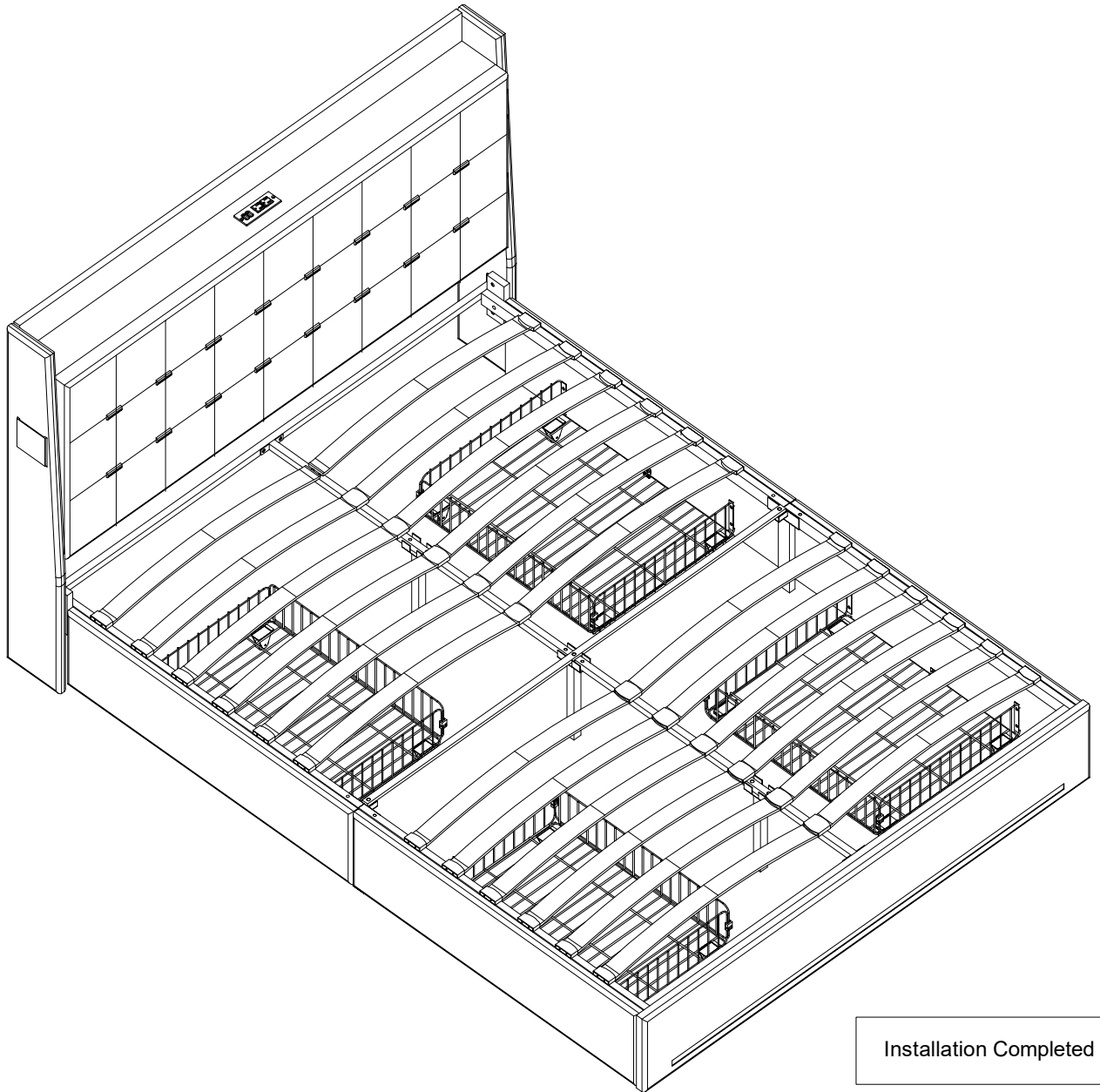

Installation Completed

Installation Abgeschlossen

Installation Complétée

Installazione Completata

Instalación Completada

## HELP CENTER



Inquiry



Assembly issue



Missing parts



Returns & Refunds

If you encounter any difficulties during assembly, please contact us.

Wenn Sie während der Montage auf Schwierigkeiten stoßen, kontaktieren Sie uns bitte.

Si vous rencontrez des difficultés lors du montage, veuillez nous contacter.

Se incontri difficoltà durante il montaggio, ti preghiamo di contattarci.

Si encuentras alguna dificultad durante el ensamblaje, por favor contáctanos.



[after-sale.cs@hotmail.com](mailto:after-sale.cs@hotmail.com)

## DISCLAIMER

Manufacturer and seller expressly disclaim any and all liability for personal injury, property damage or loss, whether direct, indirect, or incidental, resulting from the incorrect attachment, improper use, inadequate maintenance, unapproved modification, or neglect of this product.

Der Hersteller und Verkäufer lehnen ausdrücklich jegliche Haftung für Personenschäden, Sachschäden oder Verluste ab, egal ob direkt, indirekt oder zufällig, die durch falsche Anbringung, unsachgemäßen Gebrauch, unzureichende Wartung, nicht genehmigte Änderungen oder Vernachlässigung dieses Produkts entstehen.

El fabricante y vendedor renuncian expresamente a toda responsabilidad por lesiones personales, daños materiales o pérdidas, ya sean directos, indirectos o incidentales, derivados de la incorrecta colocación, uso inadecuado, mantenimiento insuficiente, modificación no aprobada o negligencia de este producto.

Il produttore e il venditore declinano espressamente ogni responsabilità per lesioni personali, danni materiali o perdite, dirette, indirette o incidentali, derivanti dall'errato fissaggio, uso improprio, manutenzione inadeguata, modifica non autorizzata o negligenza di questo prodotto.

Le fabricant et le vendeur déclinent expressément toute responsabilité en cas de blessures corporelles, de dommages matériels ou de pertes, qu'ils soient directs, indirects ou accessoires, résultant de la fixation incorrecte, de l'utilisation inappropriée, de l'entretien insuffisant, de la modification non approuvée ou de la négligence de ce produit.