







# Assembly Instructions

**NOTE: Do not use power tools for assembly. Power tools increase the risk of over tightening which lead to splitting or cracking the wood.**

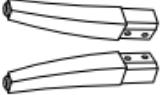
## COMPONENT LIST (ACCENT CHAIR)

NO.	DRAWING	QTY	DESCRIPTION
A		1 PC	CHAIR
B		2PCS	FRONT LEG L & R
C		2PCS	REAR LEG L & R
D		4 PCS	BOLT (M8×70mm) ( FRONT LEG )
E		4 PCS	BOLT (M8×60mm) ( REAR LEG )
F		8PCS	WASHER
G		1PC	ALLEN KEY



Legs are Hardware set are stored at the bottom seat inside the dust cover as shown in drawing, please take out for assembly.

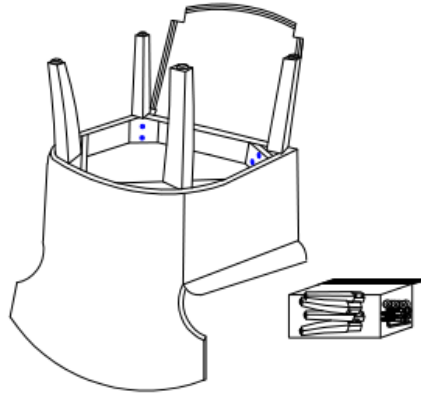

## STEP #1

### Front Leg Assembly:

Align and insert front legs to the front seat frame pre-drilled holes, make sure both pre-drilled holes are in line, insert bolts D and washers then tighten with Allen Key.

### Rear Leg Assembly:

Align and insert rear legs to the rear seat frame pre-drilled holes, rear legs curves must facing outward, make sure both pre-drilled holes are in line, insert bolts E and washers then tighten with Allen Key.

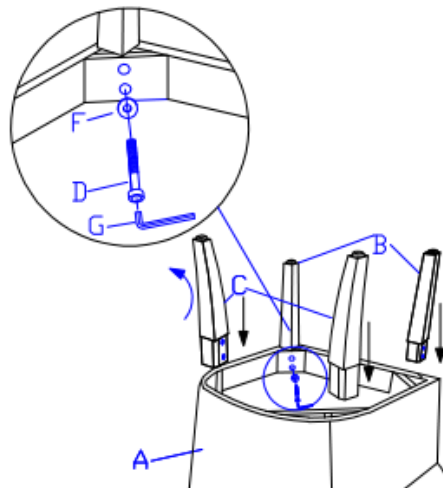

## STEP #2

Check all the bolts are tighten securely in position put the dust cover back to the position. Upright the chair and make sure the chair is stable.

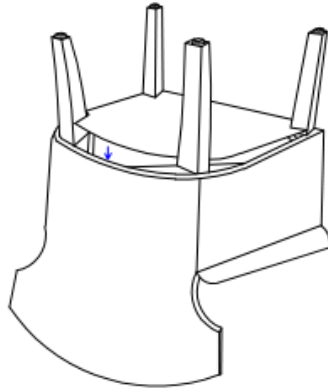

Chair Assembly is completed.

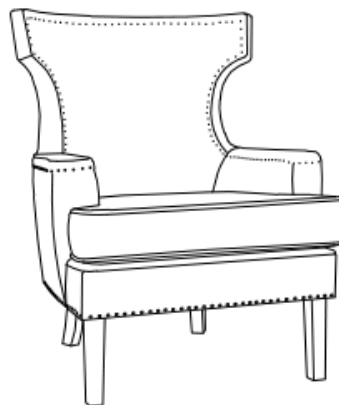

## Care instruction for 100% polyester furniture.

In order to maintain the original appearance of your 100% polyester furniture, please follow below simple care procedures:

- Avoid exposing furniture directly to sunlight or heating and air conditioning outlets.  
Sunlight and/or exposure to heating and air conditioning outlets will fade/damage fabrics.  
Do not place your upholstered furniture too close to windows, radiators, or vents, and be sure to use windows, radiators, or vents.
- Vacuum or wipe with a cloth regularly to remove dust.



**For items use on wooden floor, hard surfaces or carpets, it is recommended to Install protective pads under all legs and supports to avoid/prevent from damages/scratches and discoloration.**