







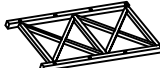

ASSEMBLY INSTRUCTIONS

PARTS LIST				HARDWARE LIST			
NO	DESCRIPTION		QTY	NO	DESCRIPTION		QTY
1	TOP		1	A	Bolt Ø6 x 5/32 x 45mm		16 sets
2	SIDE FRAME		2	B	Wood screw M4 x 20mm		8 pcs
3	SHELF FRAME		3	C	Basket frame		6 pcs
4	CROSS BAR		2	D	Basket bottom		6 pcs

STEP 1:

- PLACE TOP (1) ON A FLAT, PROTECTED SURFACE.
- ATTACH SIDE FRAME (2) TO TOP (1) WITH BOLTS (A).
- USING SCREW DRIVER (NOT PROVIDED), LOOSELY TIGHTEN.

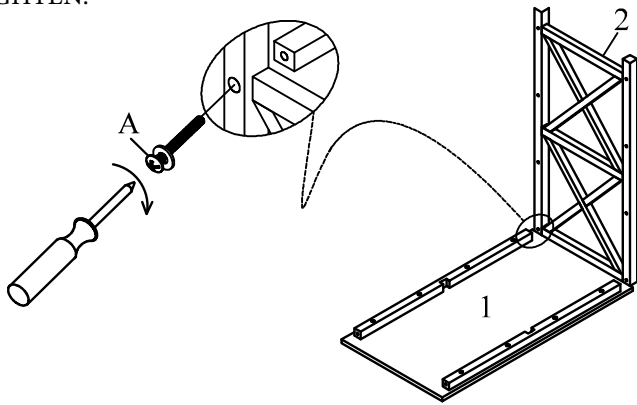

STEP 2:

- ATTACH THE OTHER SIDE FRAME (2) TO TOP (1) WITH BOLTS (A).
- USING SCREW DRIVER (NOT PROVIDED), LOOSELY TIGHTEN.

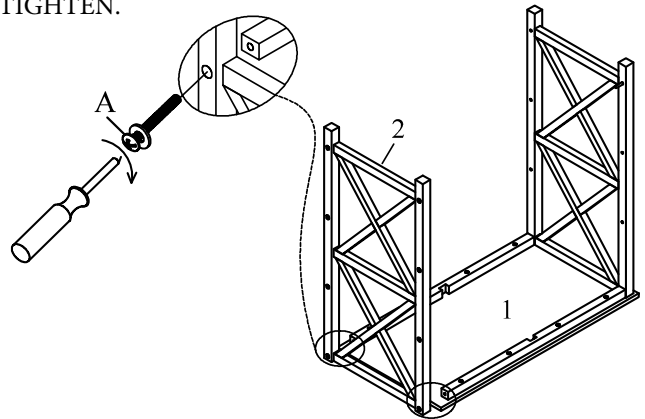

STEP 3:

- ATTACH SHELF FRAMES (3) WITH BOLTS (A)
- USING SCREW DRIVER (NOT PROVIDED), LOOSELY TIGHTEN.

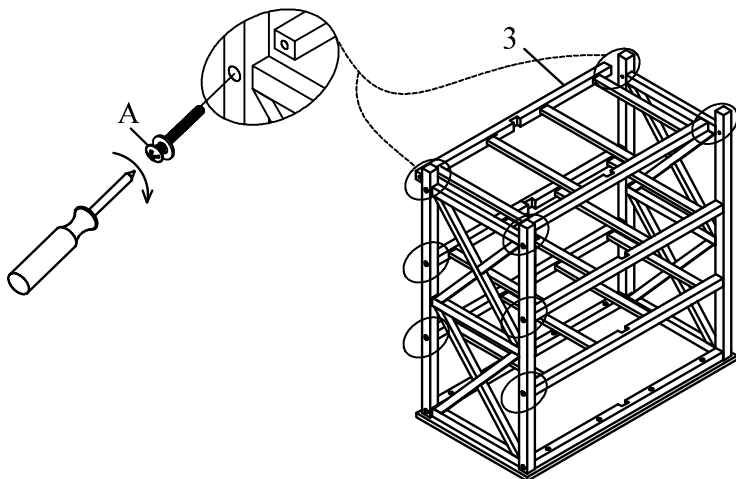

STEP 4:

- ATTACH CROSS BARS (4) TO SHELF FRAMES (3) WITH WOOD SCREWS (B).
- USING SCREW DRIVER (NOT PROVIDED).
- TIGHTEN ALL BOLTS AND WOOD SCREWS.

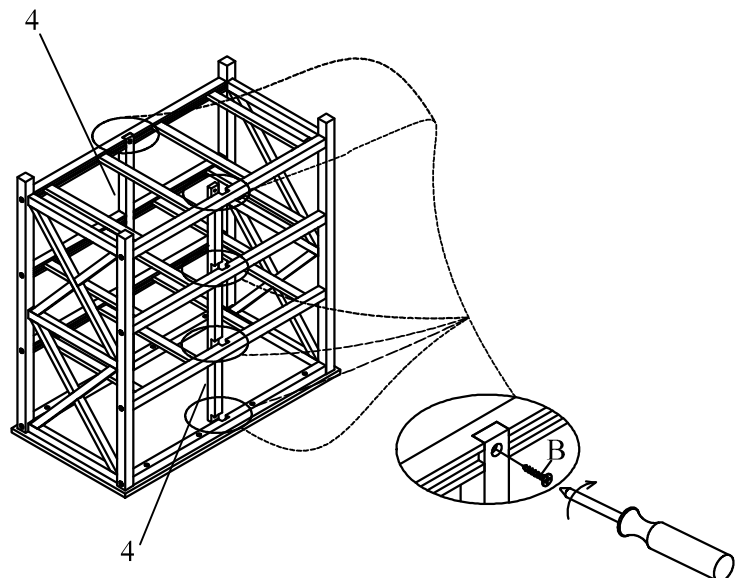

ASSEMBLY INSTRUCTIONS

STEP 5:

- A. ROTATE THE ASSEMBLED UNIT TO UPRIGHT POSITION.
- B. INSERT BASKET BOTTOM (D) INTO BASKET FRAME (C). REPEAT FOR REMAINING BASKETS.
- C. PLACE THE BASKETS INTO TOWER AS SHOWN.

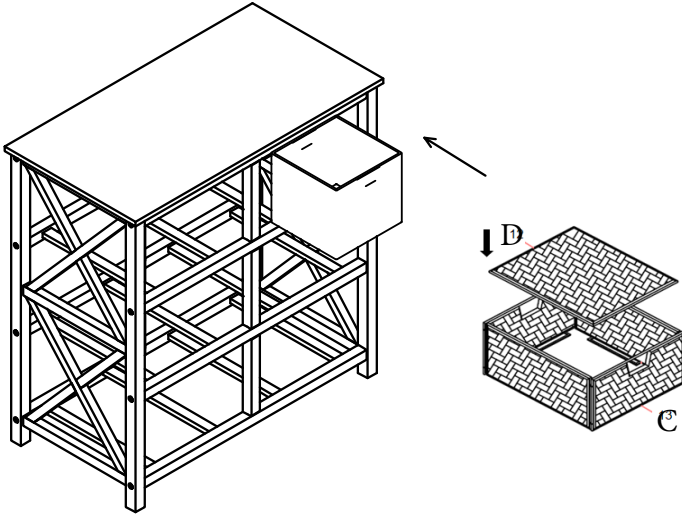

STEP 6:

- A. ASSEMBLY IS COMPLETE.

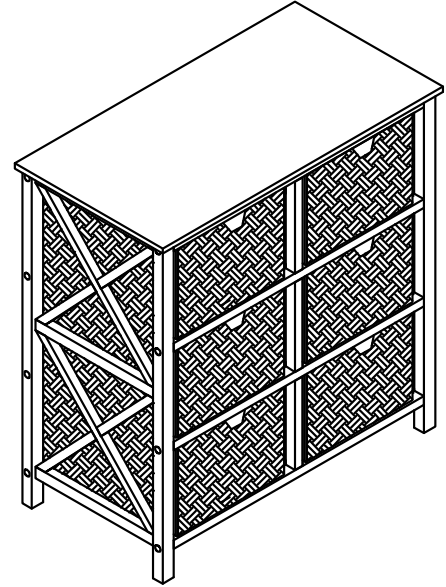

IMPORTANT NOTE:

- PLACE ALL WOODEN PARTS ON A CLEAN AND SMOOTH SURFACE TO AVOID SCRATCHING.
- KINDLY FOLLOW THE ASSEMBLY INSTRUCTION STEP BY STEP.
- WE RECOMMEND THAT YOU PERIODICALLY TIGHTEN ALL BOLTS/SCREWS. PLEASE MAKE SURE ALL BOLTS/ SCREWS ARE PLACED IN THEIR PROPER POSITION AND ARE TIGHTENED SECURELY TO ENSURE YOUR SAFETY.
- WEIGHT RESTRICTION: 25 LBS.
- DO NOT STAND OR CLIMB ON THE TOWER.
- NOT FOR COMMERCIAL USE.