

# Montageanleitung | Instructions de montage Assembly Instructions | Instrucciones de montaje

V1.0

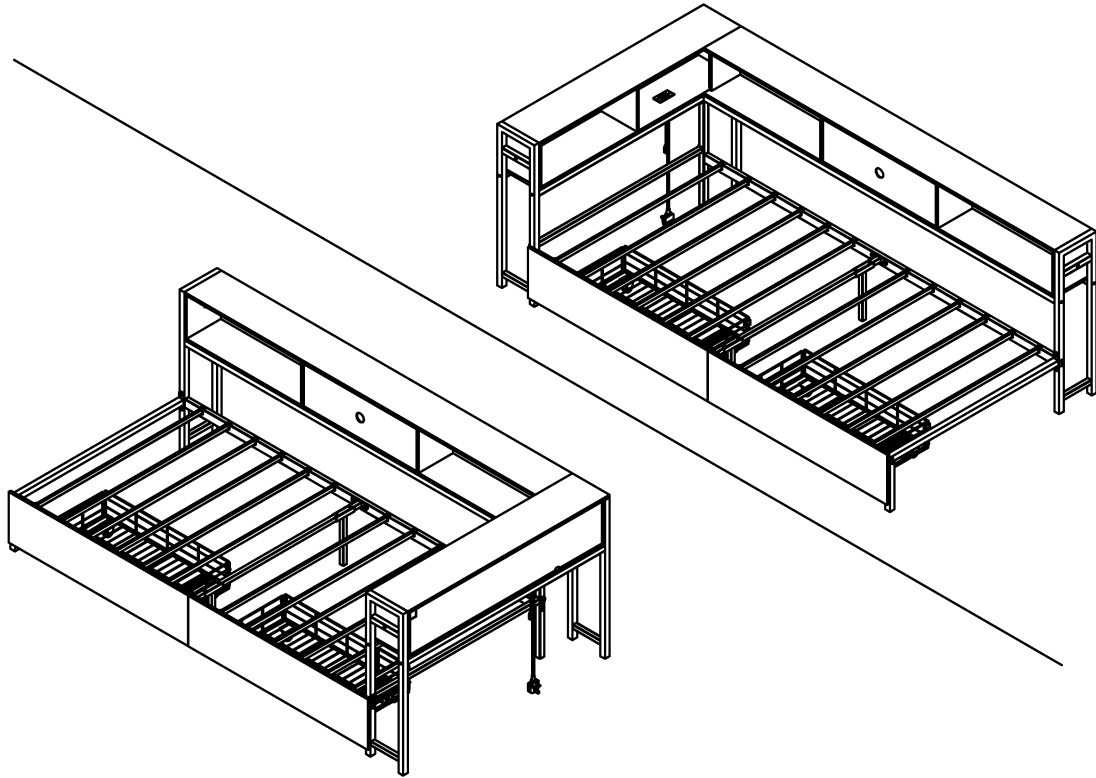

**GB** This set comes in 2 boxes. If you do not receive a full set of 2 boxes, please contact our customer service.

**DE** Dieses Set wird in 2 Schachteln geliefert. Wenn Sie nicht ein komplettes Set von 2 Boxen erhalten, kontaktieren Sie bitte unseren Kundenservice.

**FR** Ce set est livré en 2 boîtes. Si vous ne recevez pas un jeu complet de 2 boîtes, veuillez contacter notre service clientèle.

## English

**IMPORTANT ! KEEP FOR FUTURE REFERENCE : READ CAREFULLY**

- To be assembled by an adult. Assembly must be checked by an adult before use
- **WARNING !** Keep all screws, small parts and plastic bags out of the reach of children
- Properly identify all parts before assembling
- Never use your item if any of its parts are broken or missing
- Should any problems arise, please contact our After Sales Service
- Manufacturer's instructions shall be followed at all times
- Care: Clean with a soft, dry cloth. In case of larger stains, carefully rub with a slightly damp, non-abrasive sponge
- Do not jump on the bed

## Français

**IMPORTANT ! CONSERVER POUR RÉFÉRENCE ULTÉRIEURE : LIRE ATTENTIVEMENT**

- Le montage doit être effectué par un adulte. Le montage doit être vérifié par un adulte avant utilisation
- **ATTENTION !** Tenir les vis, les petites pièces et les sachets en plastique hors de portée des enfants
- Identifiez correctement toutes les pièces avant de les assembler
- N'utilisez jamais votre article si l'une de ses pièces est cassée ou manquante
- En cas de problème, veuillez contacter notre service après-vente
- Les instructions du fabricant doivent être respectées à tout moment
- Entretien : nettoyer avec un chiffon doux et sec. En cas de taches plus importantes, frotter soigneusement avec une éponge non abrasive légèrement humide. légèrement humide et non abrasive
- Ne pas sauter sur le lit

## Deutsch

**WICHTIG ! ZUM SPÄTEREN NACHSCHLAGEN AUFBEWAHREN: SORGFÄLTIG LESEN**

- Muss von einem Erwachsenen zusammengebaut werden. Der Zusammenbau muss vor dem Gebrauch von einem Erwachsenen überprüft werden
- **WARNUNG!** Bewahren Sie alle Schrauben, Kleinteile und Plastikbeutel außerhalb der Reichweite von Kindern auf
- Kennzeichnen Sie vor dem Zusammenbau alle Teile richtig.
- Benutzen Sie Ihren Artikel niemals, wenn Teile gebrochen sind oder fehlen
- Sollten Probleme auftreten, wenden Sie sich bitte an unseren Kundendienst
- Die Anweisungen des Herstellers sind stets zu befolgen
- Pflege: Mit einem weichen, trockenen Tuch reinigen. Bei größeren Flecken vorsichtig mit einem leicht feuchten, nicht scheuernden Schwamm abreiben. nicht scheuernden Schwamm
- Nicht auf das Bett springen



## More Tips



1

**English** - Before installation, you can place the parts on a carpet or other soft fabric, in order to avoid damaging your floor.

**Français** - Avant l'installation, vous pouvez placer les pièces sur un tapis ou un autre tissu doux, afin d'éviter d'endommager votre sol.

**Deutsch** - Vor der Installation können Sie die Teile auf einen Teppich oder ein anderes weiches Material legen, um eine Beschädigung Ihres Fußbodens zu vermeiden.

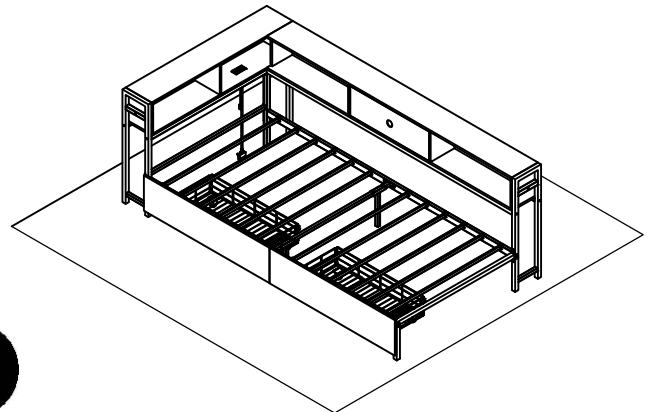
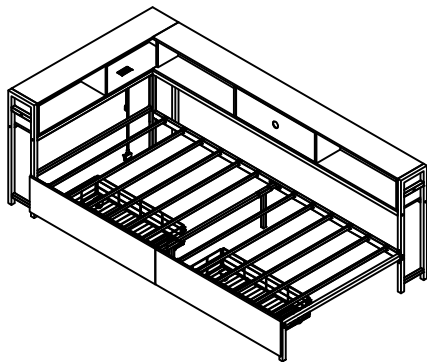

2

**English** - For your and your family's safety, please do not jump on beds, especially with hydraulic structures. When need to move bed, please work with more than one person to lift, not push, to avoid scratching your floor and hurting the stability of the bed.

**Français** - Pour votre sécurité et celle de votre famille, ne sautez pas sur les lits, en particulier sur les structures hydrauliques. Lorsqu'il est nécessaire de déplacer le lit, il est préférable de travailler à plusieurs pour le soulever, et non pour le pousser, afin d'éviter de rayer le sol et de nuire à la stabilité du lit.

**Deutsch** - Zu Ihrer Sicherheit und der Ihrer Familie sollten Sie nicht auf Betten springen, insbesondere bei hydraulischen Konstruktionen. Wenn Sie das Bett bewegen müssen, heben Sie es bitte mit mehreren Personen an und schieben Sie es nicht, um den Boden nicht zu verkratzen und die Stabilität des Bettes nicht zu beeinträchtigen.

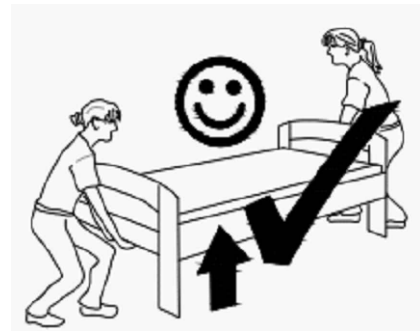

\*This bed has two assembly methods; please choose one according to your needs.

\*Dieses Bett hat zwei Montagemethoden; Bitte wählen Sie eine nach Ihren Bedürfnissen.

\*Ce lit a deux méthodes d'assemblage; s'il vous plaît choisir un selon vos besoins.

\*Esta cama tiene dos métodos de montaje; Por favor elija uno según sus necesidades.

\*Questo letto ha due metodi di assemblaggio; Scegli uno secondo le tue esigenze.

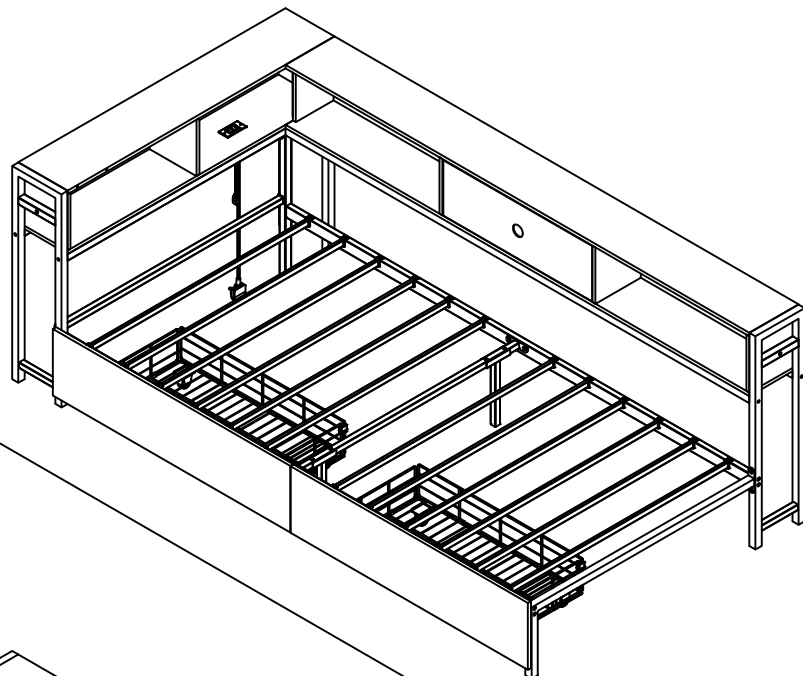

1.



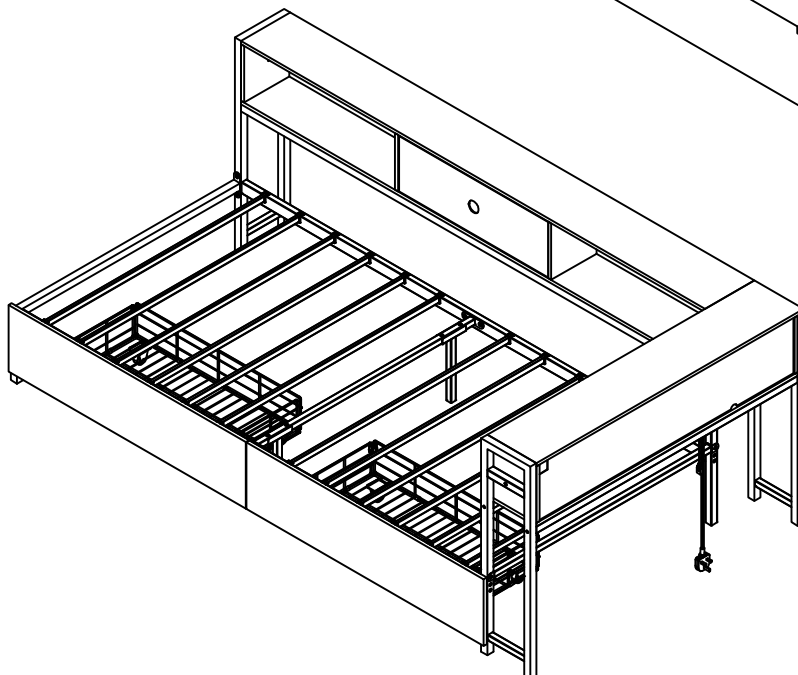

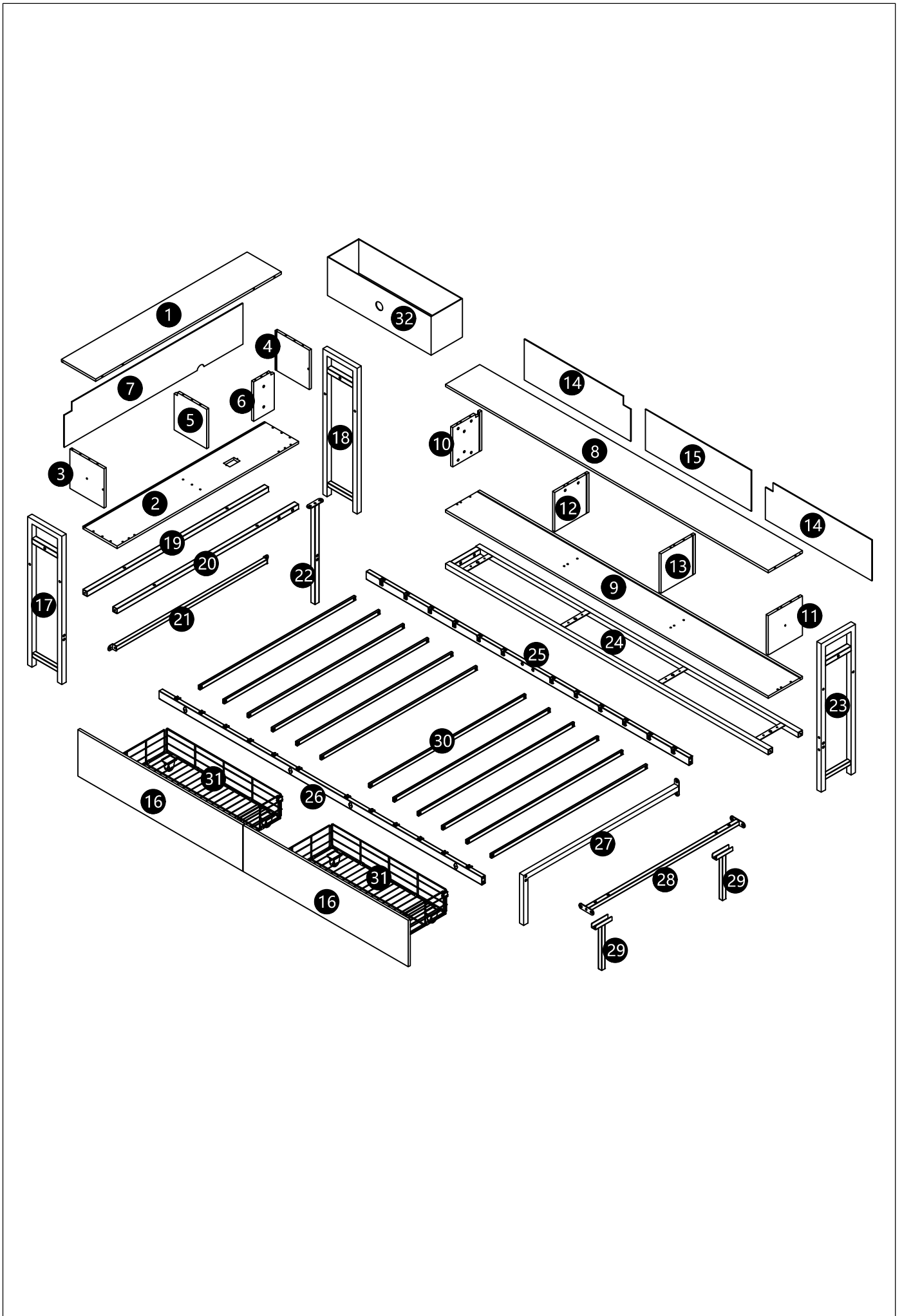

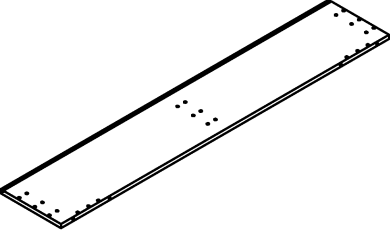
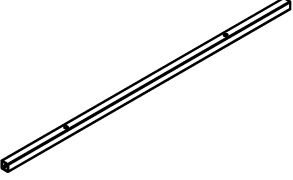
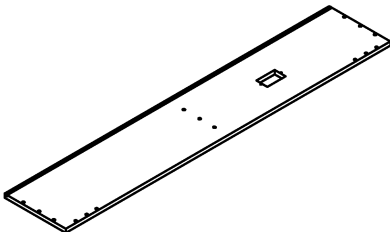
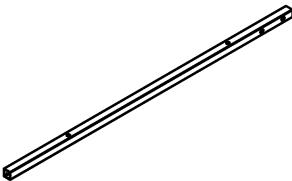
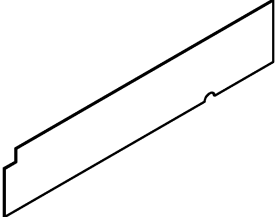
2.

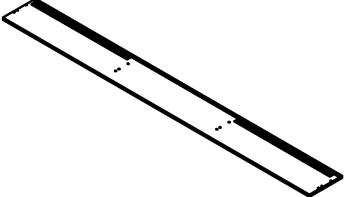
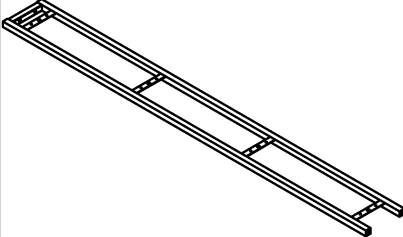
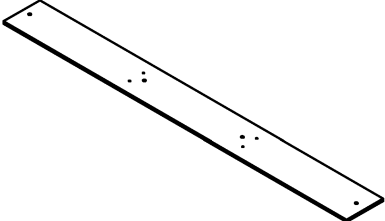
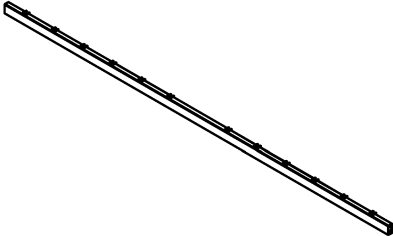
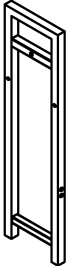
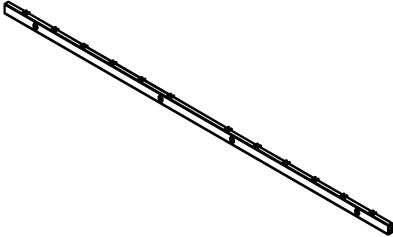

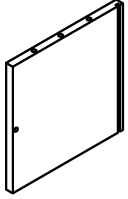
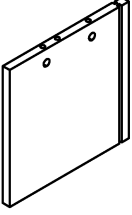
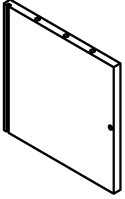
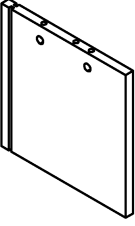
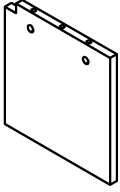
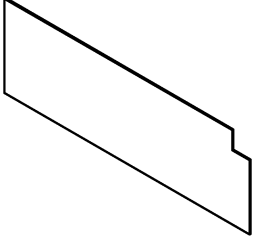
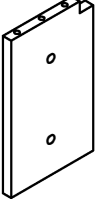
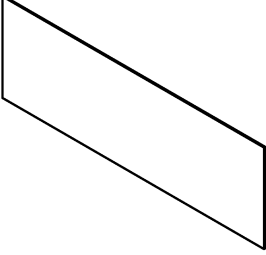
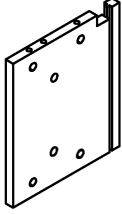
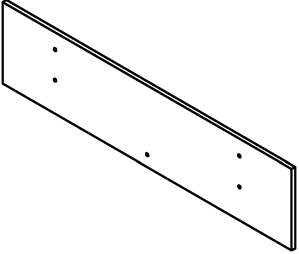
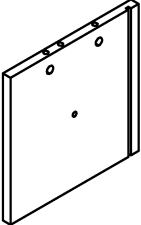
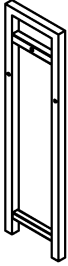

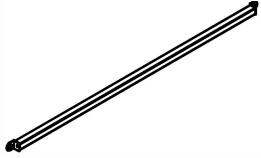
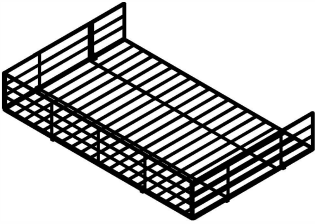
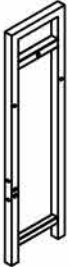
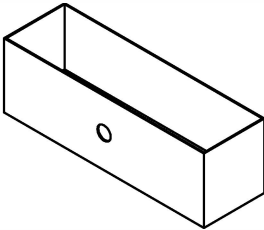
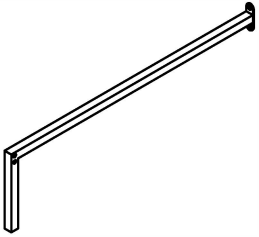
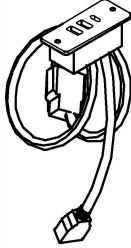
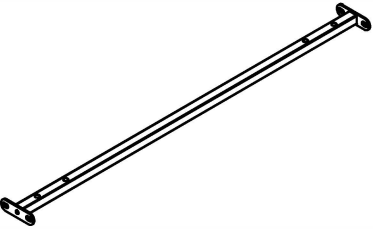
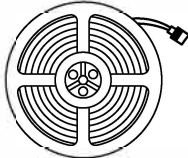
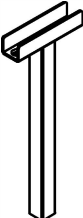

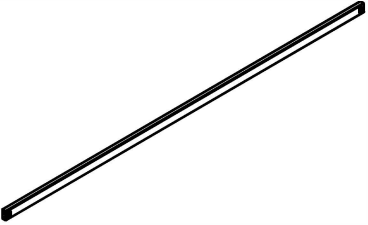











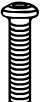

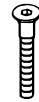

1		X1	19		X1
2		X1	20		X1
7		X1	22		X1
8		X1	24		X1
9		X1	25		X1
17		X1	26		X1



3		X1	12		X1
4		X1	13		X1
5		X1	14		X2
6		X1	15		X1
10		X1	16		X2
11		X1	18		X1

21		X1	31		X2
23		X1	32		X1
27		X1	33		X1
28		X1	35	 Light strip	X1
29		X2	36	 Power cord	X1
30		X12	37		X8

# Hardware List-Hardware-Liste-Liste du matériel

<b>A</b>	 M6*10	X4+1	<b>G</b>	 M8*35	X4+1	<b>N</b>	 Ø6	X18+2
<b>B</b>	 M6*33	X7+1	<b>H</b>	 M8*55	X10+1	<b>O</b>	 M5	X1
<b>C</b>	 M6*45	X6+1	<b>J</b>	 M3*12	X2+1	<b>P</b>	 M6	X1
<b>D</b>	 M8*10	X10+1	<b>K</b>	 M5*35	X14+1	<b>Q</b>	 M8	X1
<b>E</b>	 M8*20	X12+1	<b>L</b>	 	X20+2	<b>R</b>	 	X1
<b>F</b>	 M8*23	X2+1	<b>M</b>	 	X20+2	<b>S</b>	 Magic tape	X3

# Hardware List-Hardware-Liste-Liste du matériel

<b>T</b>		X6+1						
<b>U</b>		X4+1						

\*Pages 13–35 cover Assembly Method 1, and pages 36–58 cover Assembly Method 2.

\*Seiten 13-35 umfassen die Montagemethode 1 und Seiten 36-58 die Montagemethode 2.

\*Les pages 13 à 35 couvrent la méthode d'assemblage 1, et les pages 36 à 58 couvrent la méthode d'assemblage 2.

\*Las páginas 13-35 cubren el Método de Asamblea 1, y las páginas 36-58 cubren el Método de Asamblea 2.

\*Le pagine 13-35 riguardano il metodo di assemblaggio 1, e le pagine 36-58 riguardano il metodo di assemblaggio 2.

1.

\*Assembly Method 1

\*Montagemethode 1

\*Méthode d'assemblage 1

\*Método de montaje 1

\*Metodo di assemblaggio 1

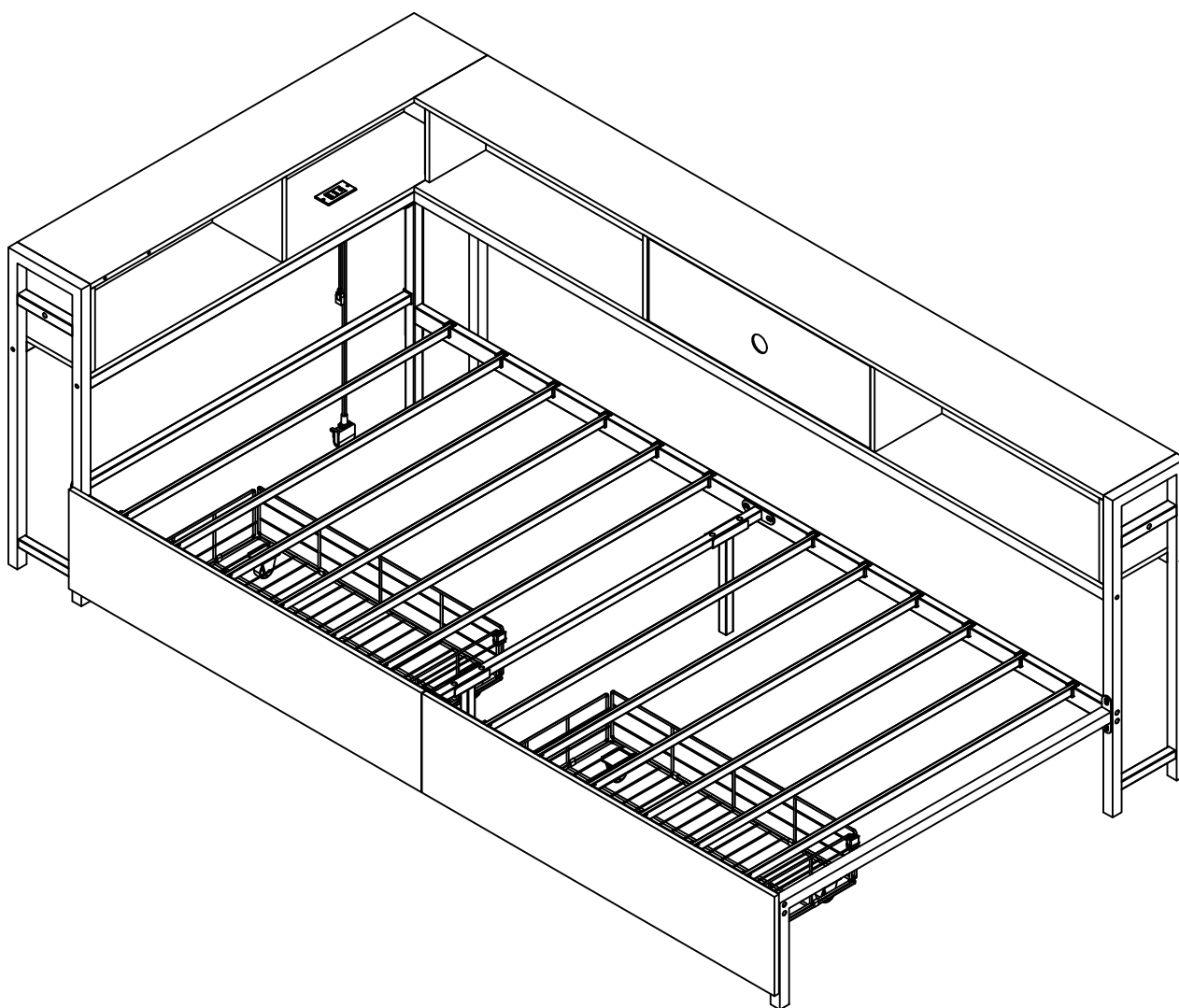

# 1

Ø6  
NX3pcs

LX6pc

RX1pc

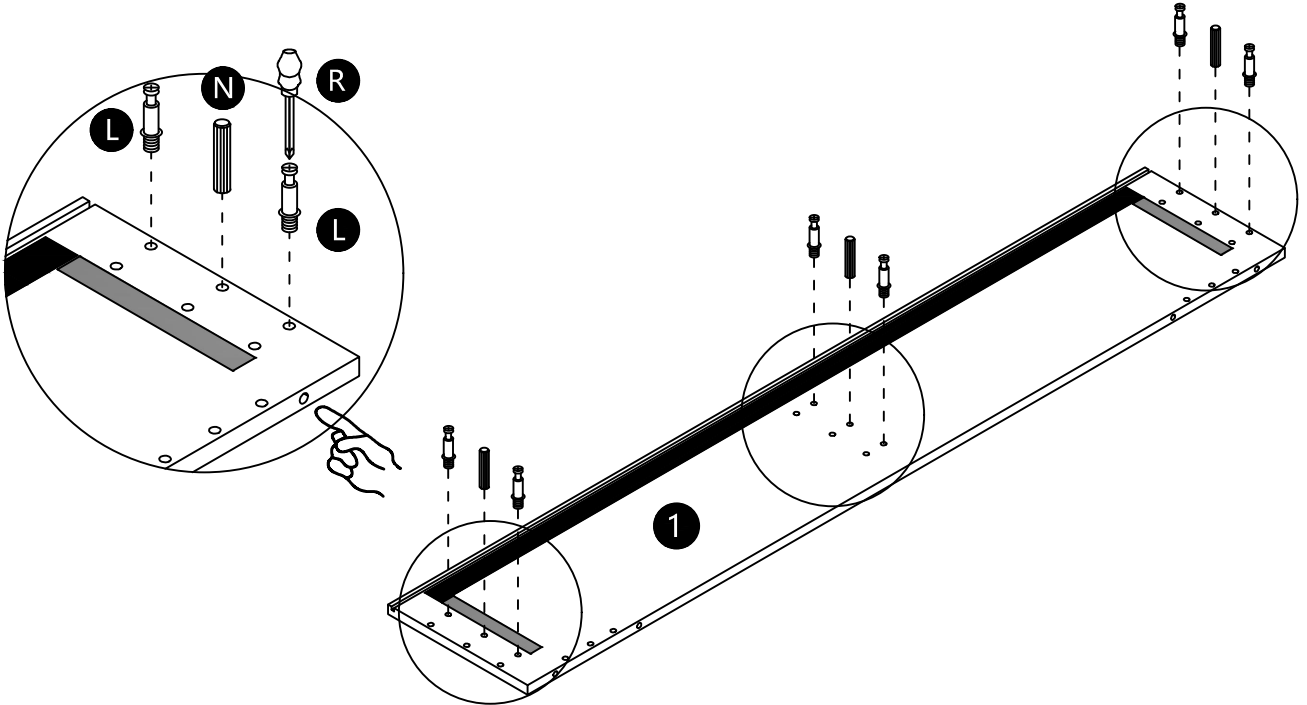

# 2

MX6pcs

RX1pc

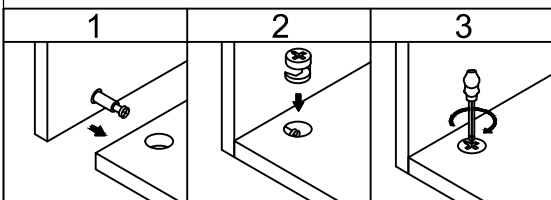
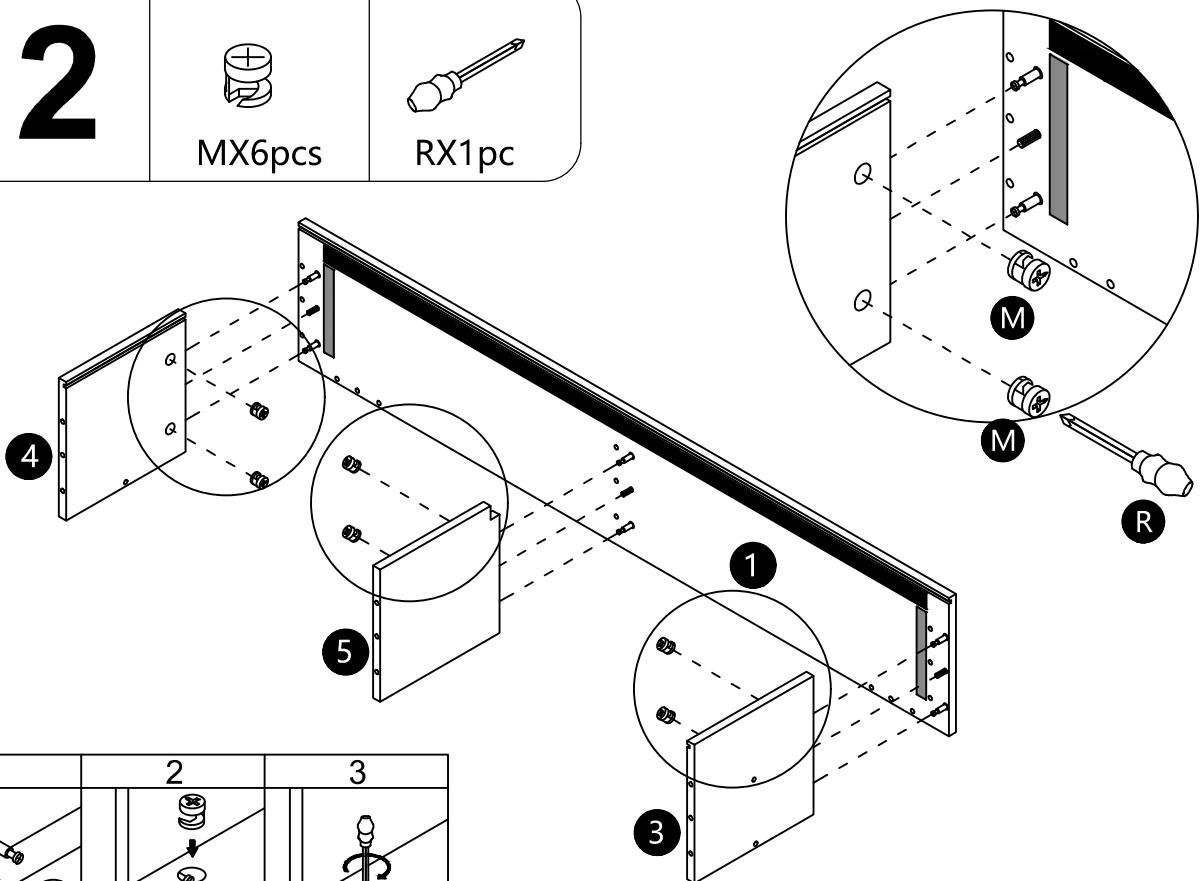

# 3

Ø6  
NX1pcs

LX2pc

RX1pc

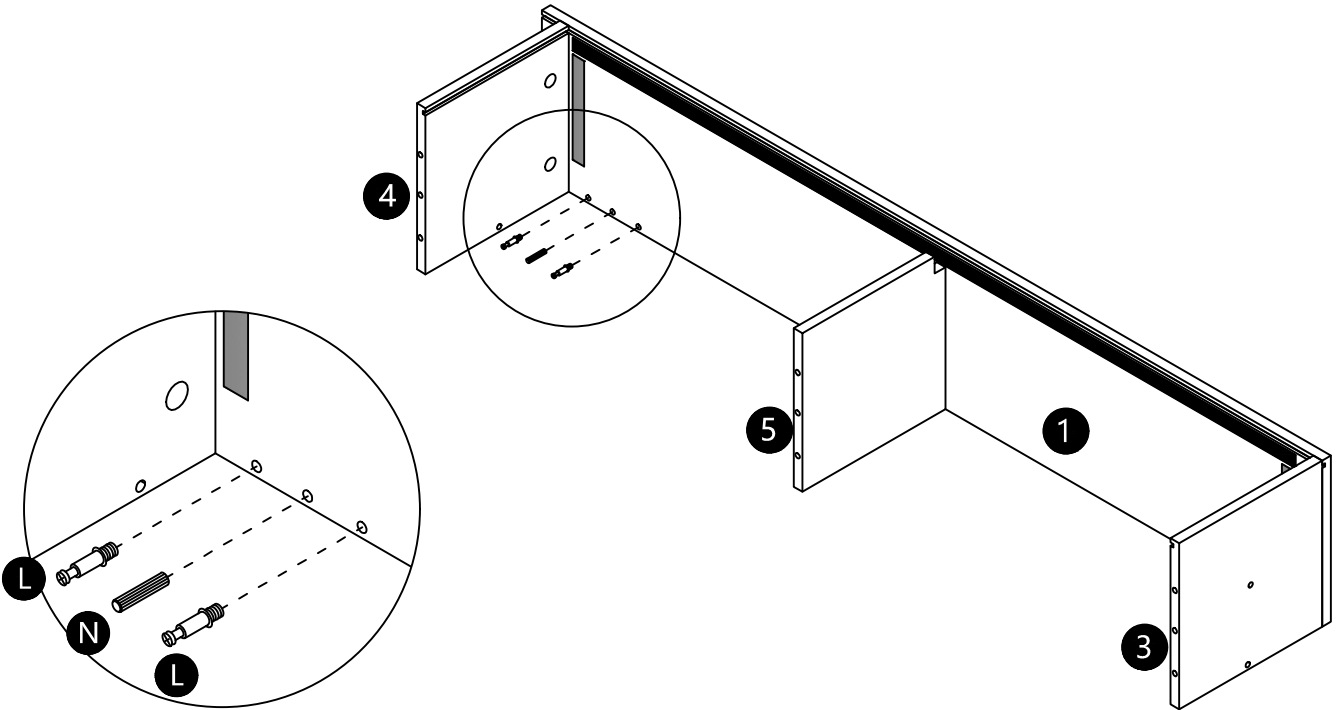

# 4

MX2pcs

RX1pc

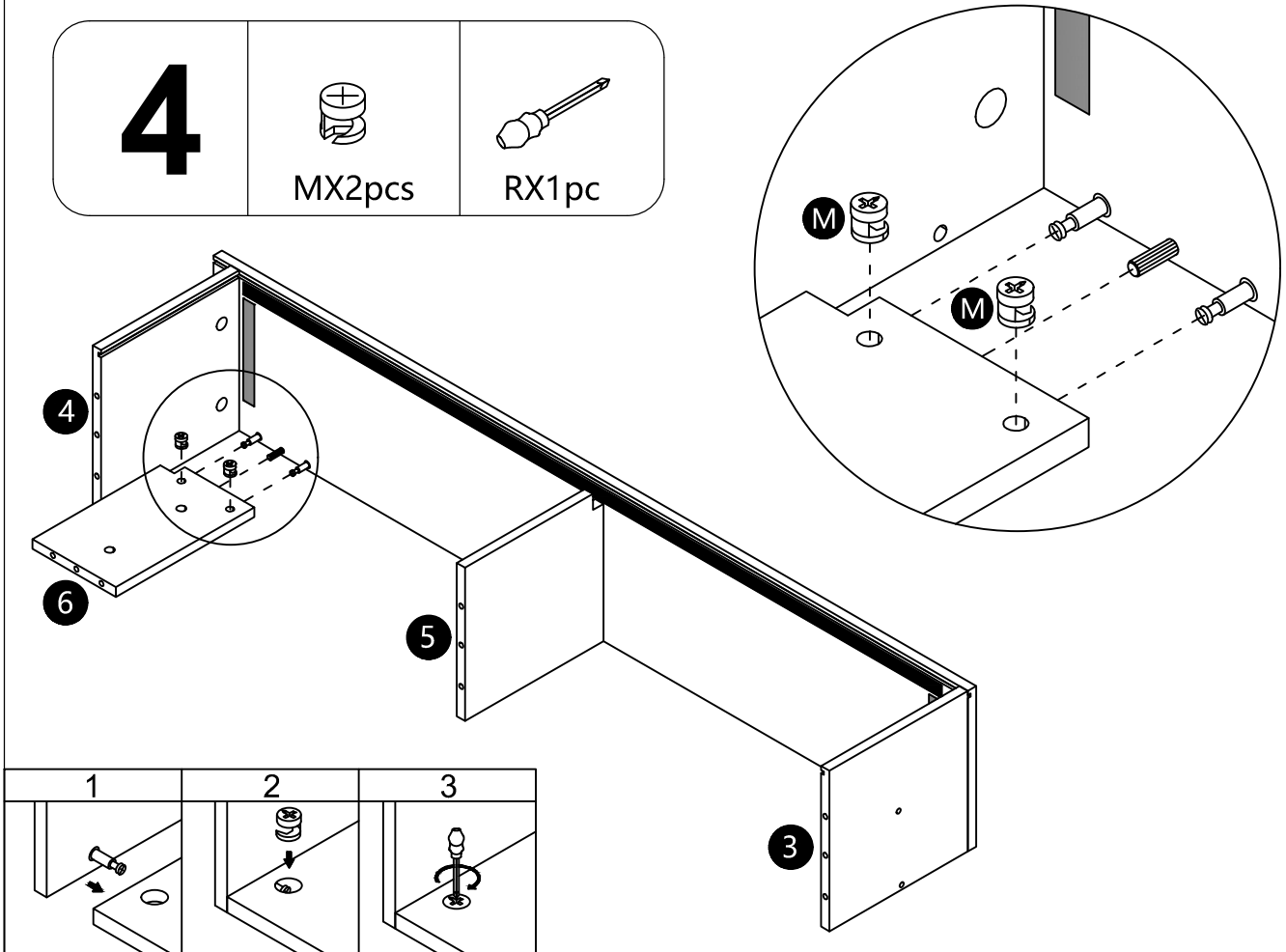

# 5

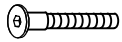

M5\*35  
KX1pcs



M5  
OX1pc

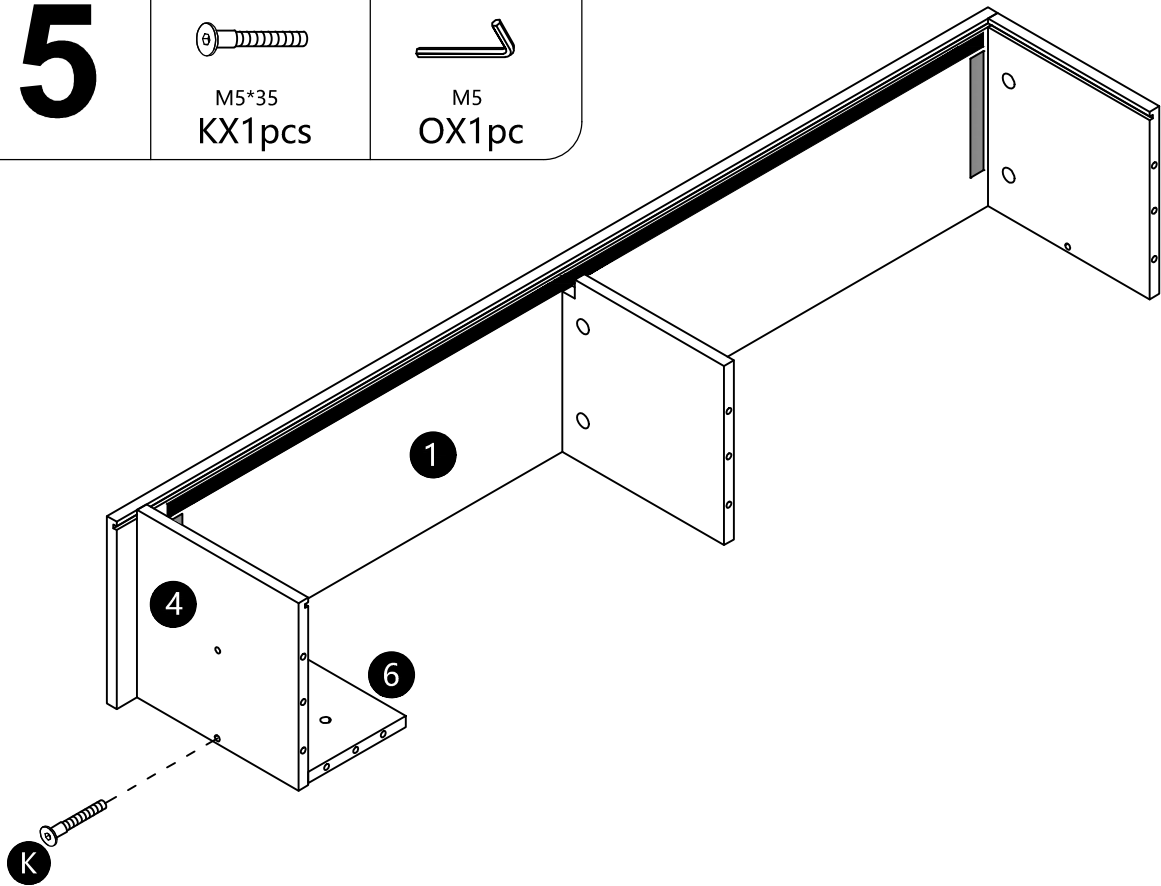

# 6

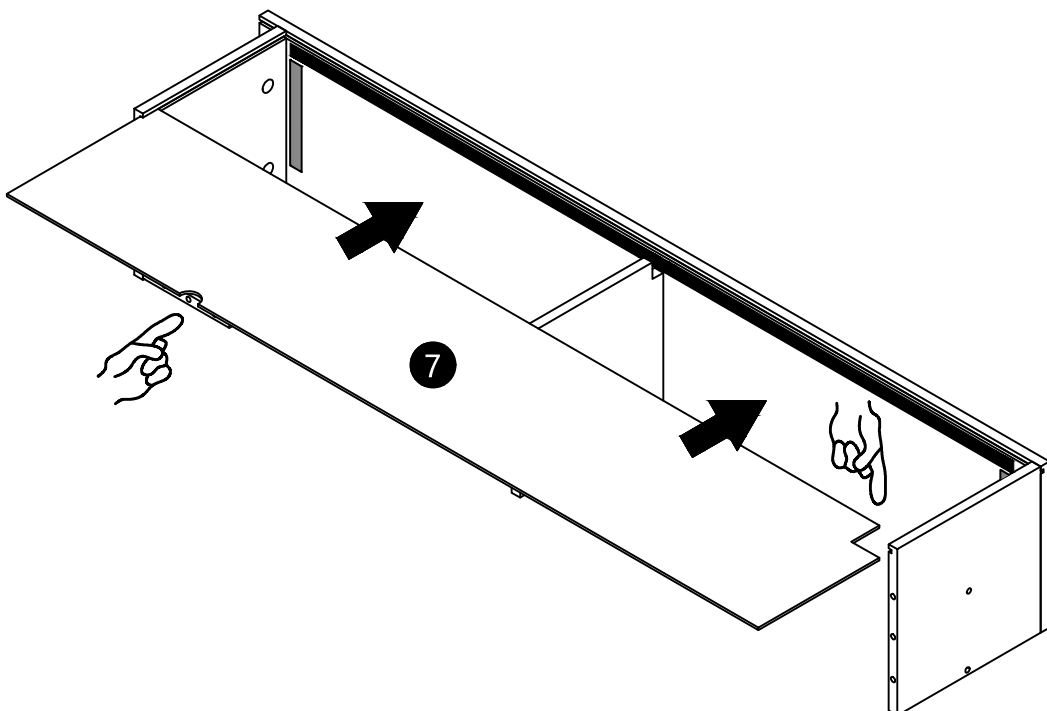

# 7



Ø6  
NX4pcs

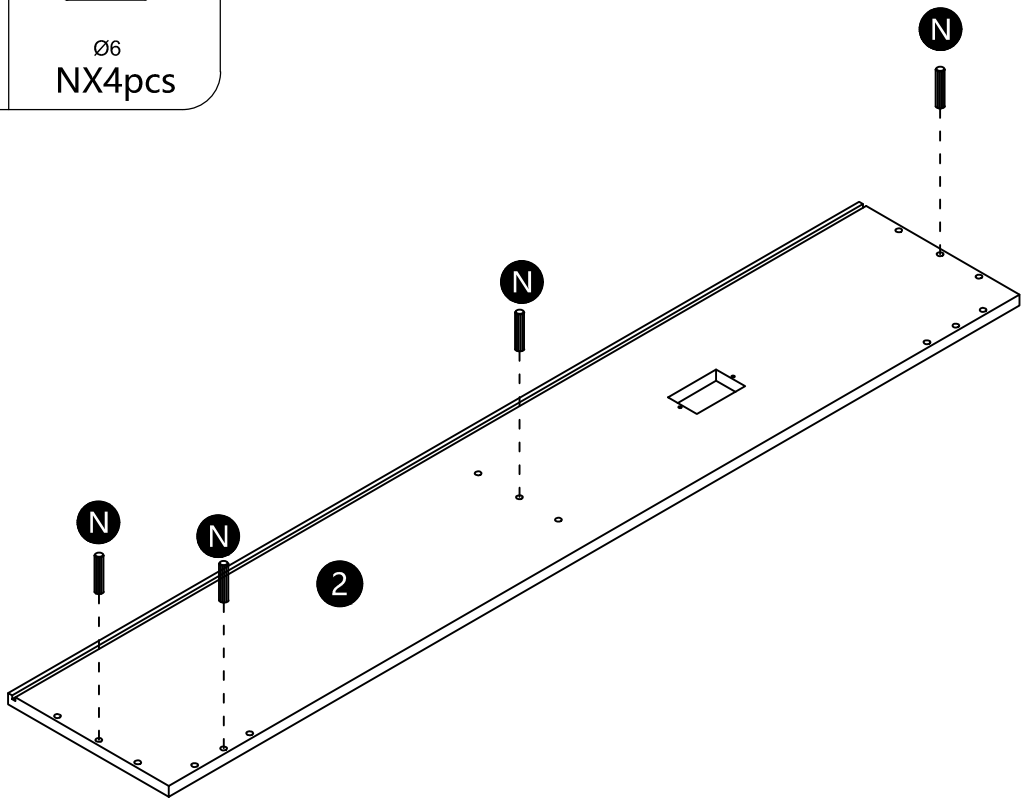

# 8

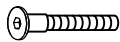

M5\*35  
KX8pcs



M5  
OX1pc

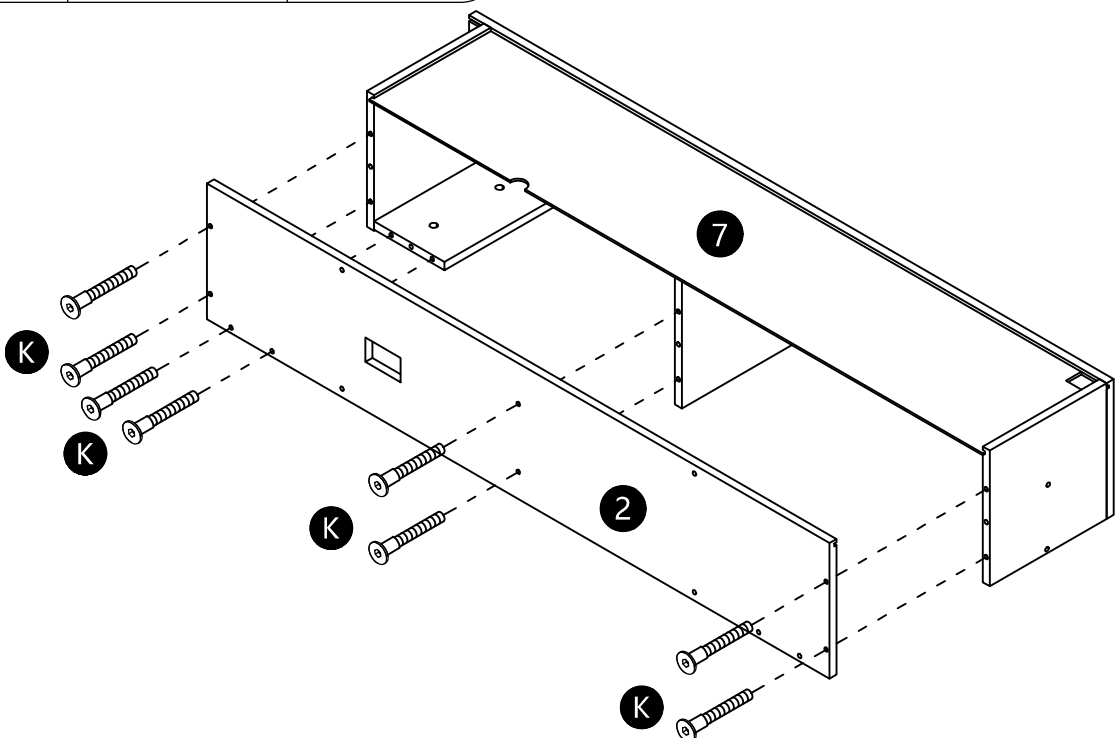

# 9

M6\*33  
BX4pcs

M6  
PX1pc

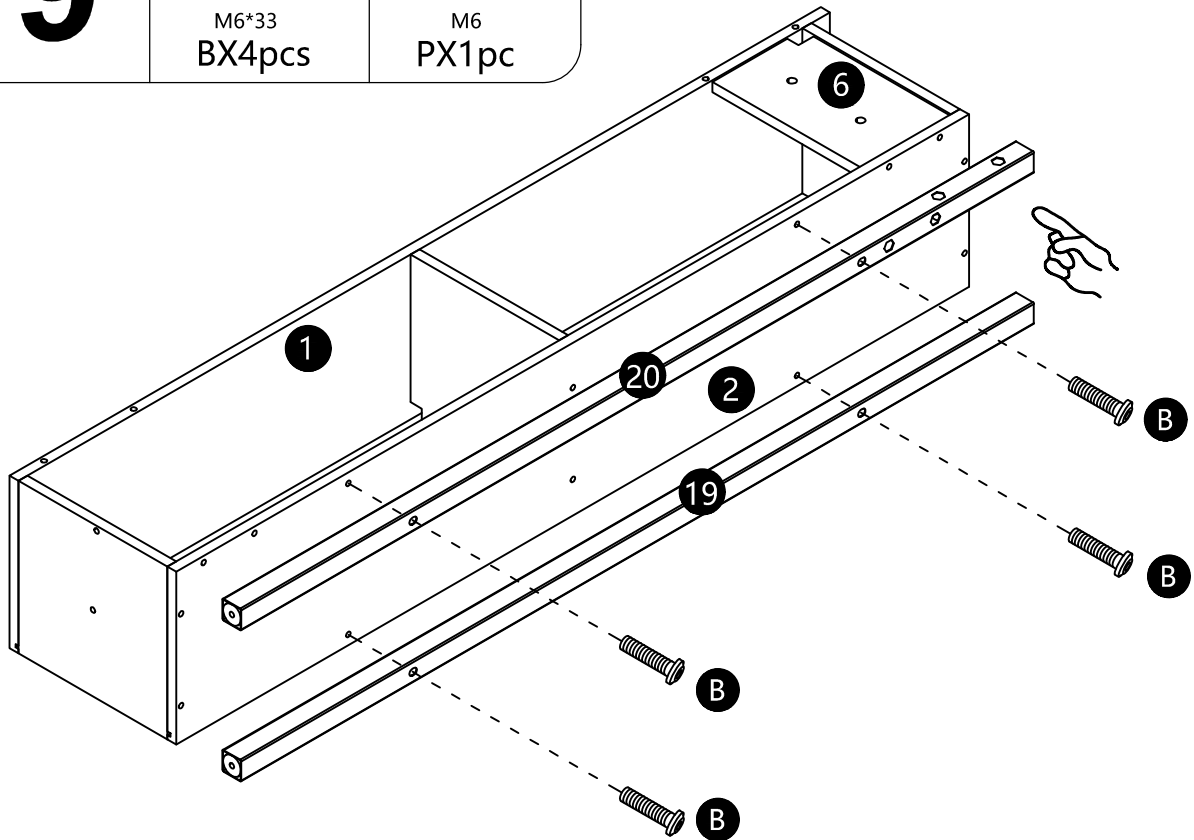

# 10

M6\*33  
BX2pcs

M6\*45  
CX4pcs

M6  
PX1pc

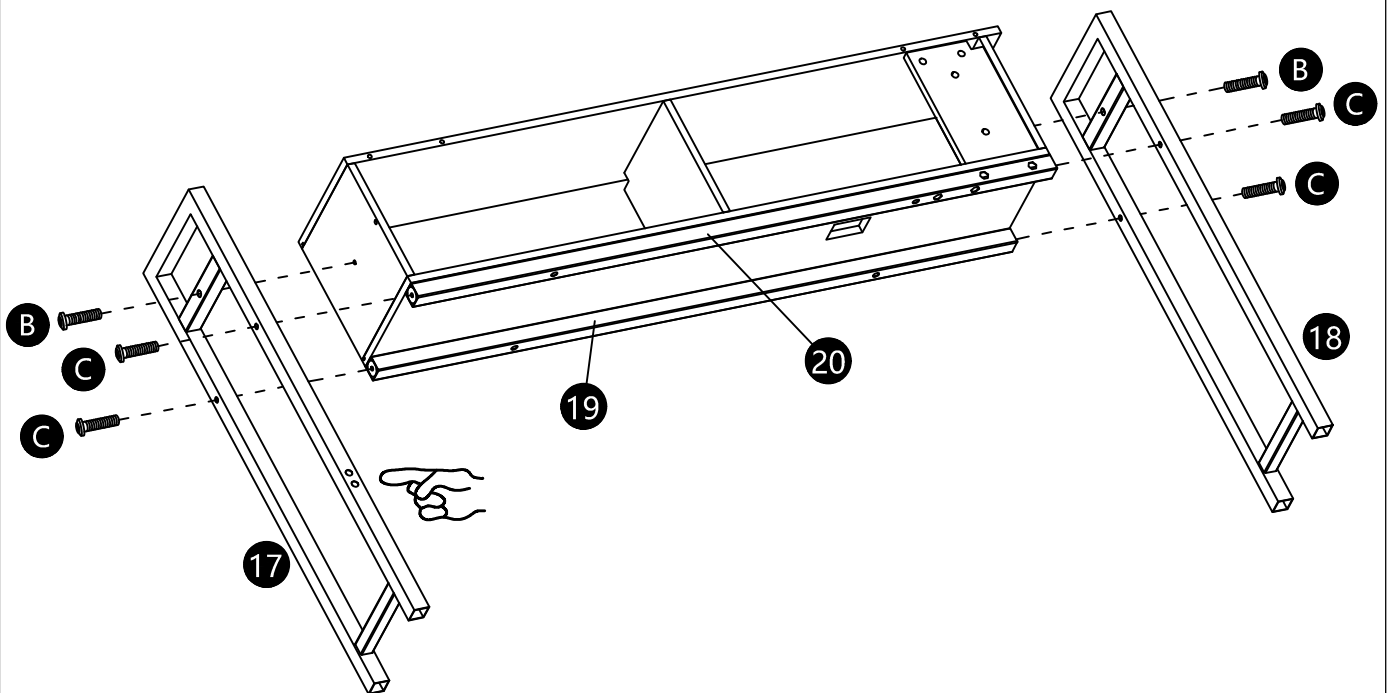

# 11



M8\*20  
EX2pcs

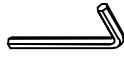

M8  
QX1pc

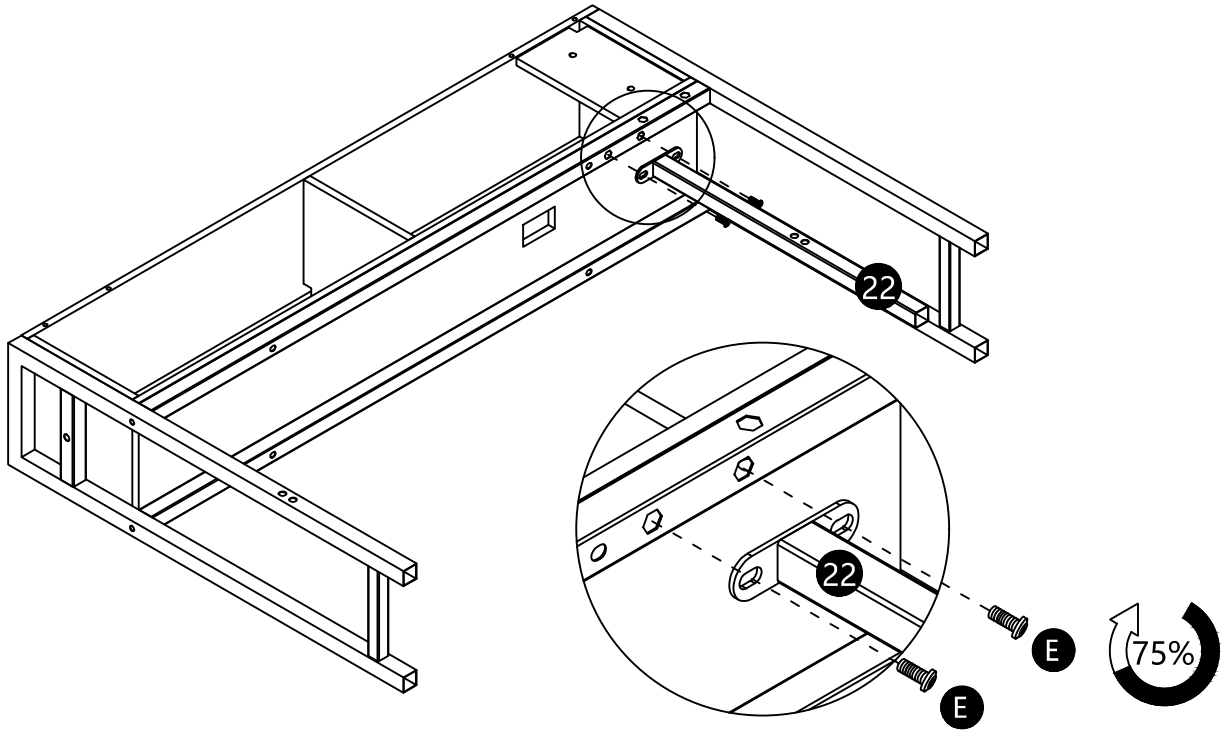

# 12



M8\*20  
EX2pcs

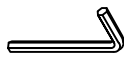

M8  
QX1pc

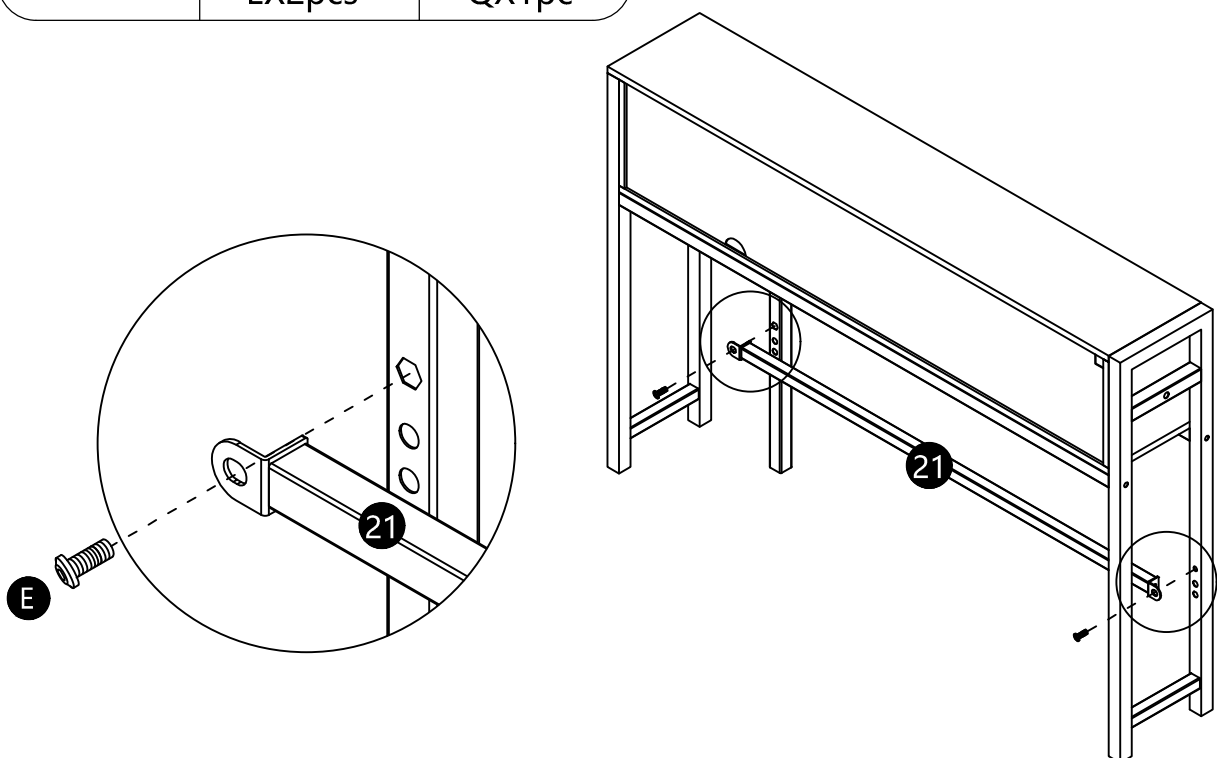

# 13



Ø6  
NX4pcs



LX8pcs

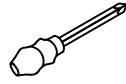

RX1pc

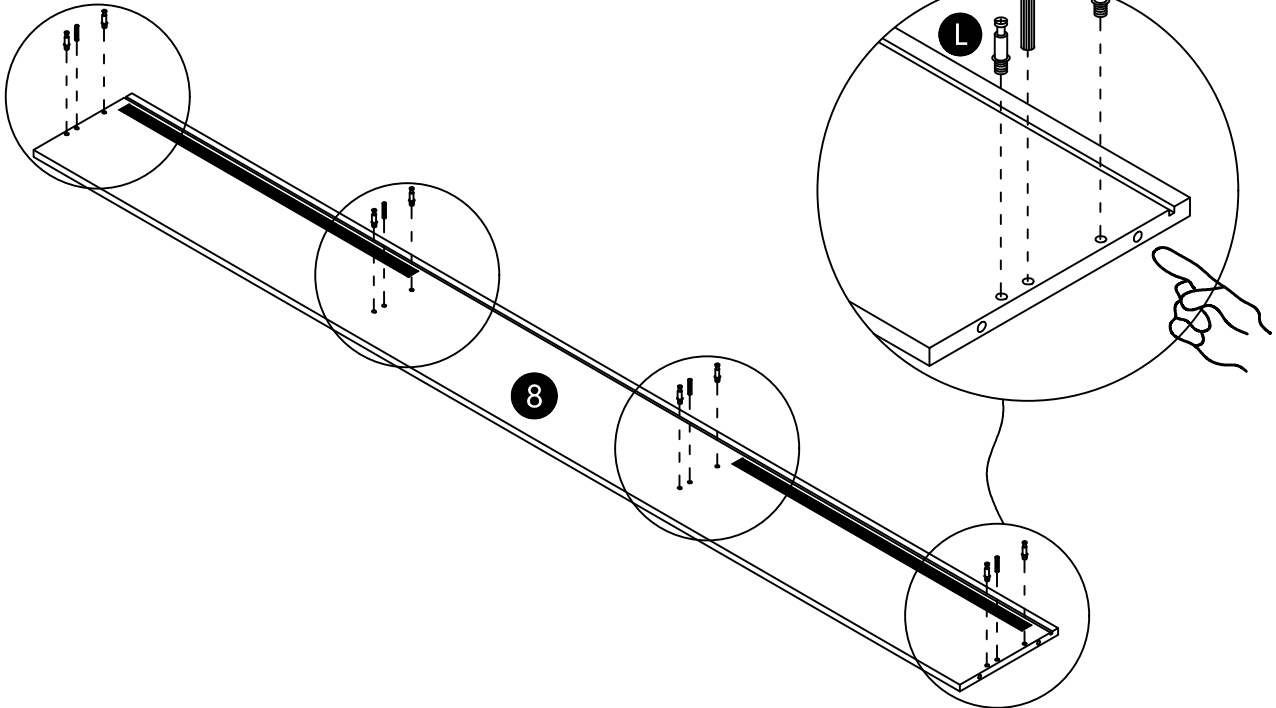

# 14



MX8pcs

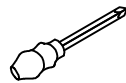

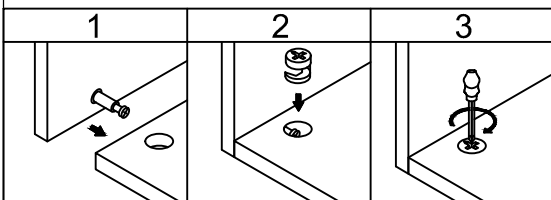
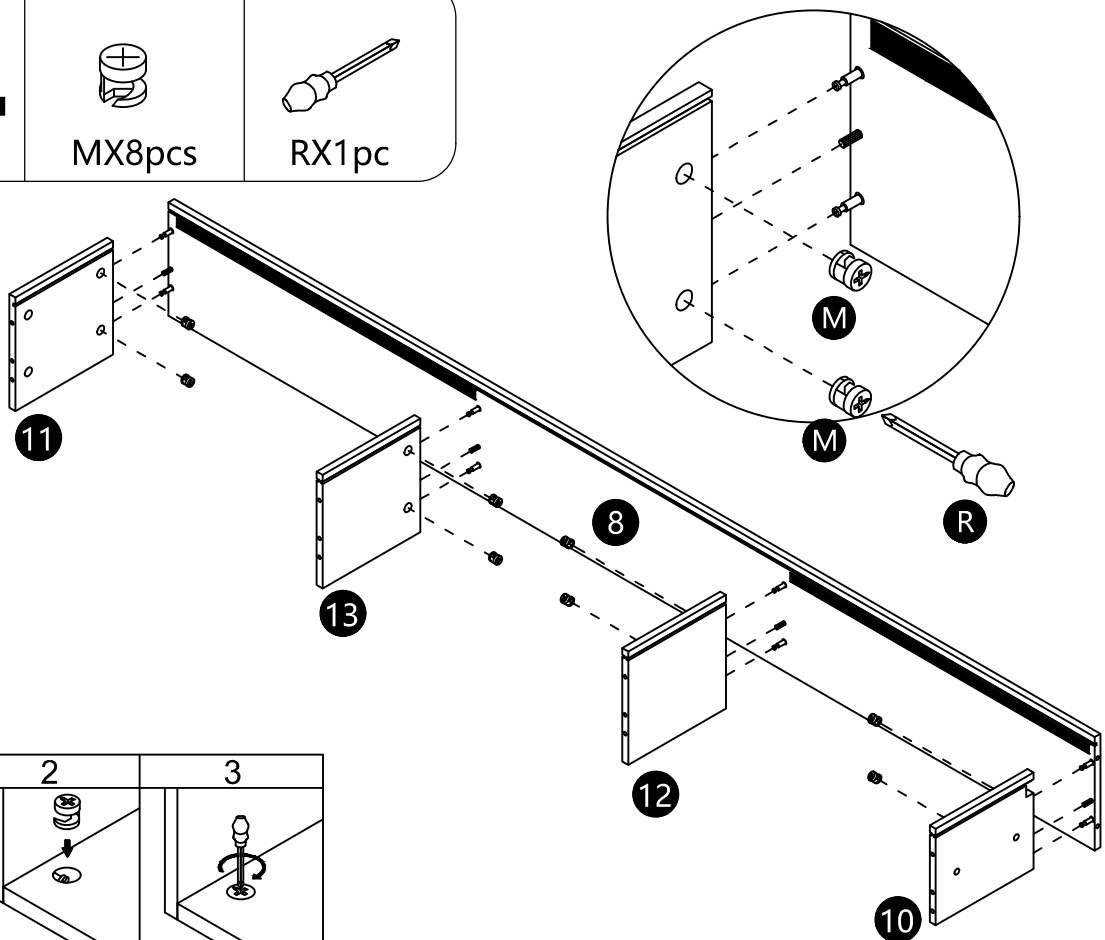

RX1pc

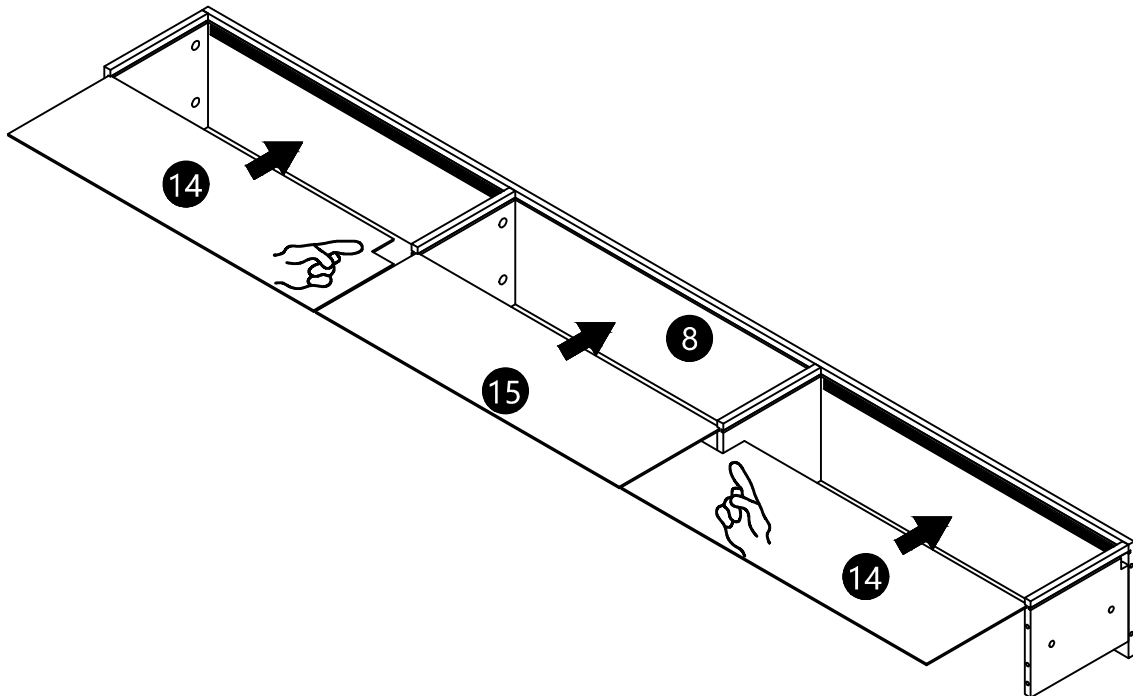

# 15

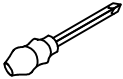

<h1>16</h1>			
	Ø6 NX4pcs	LX4pc	RX1pc

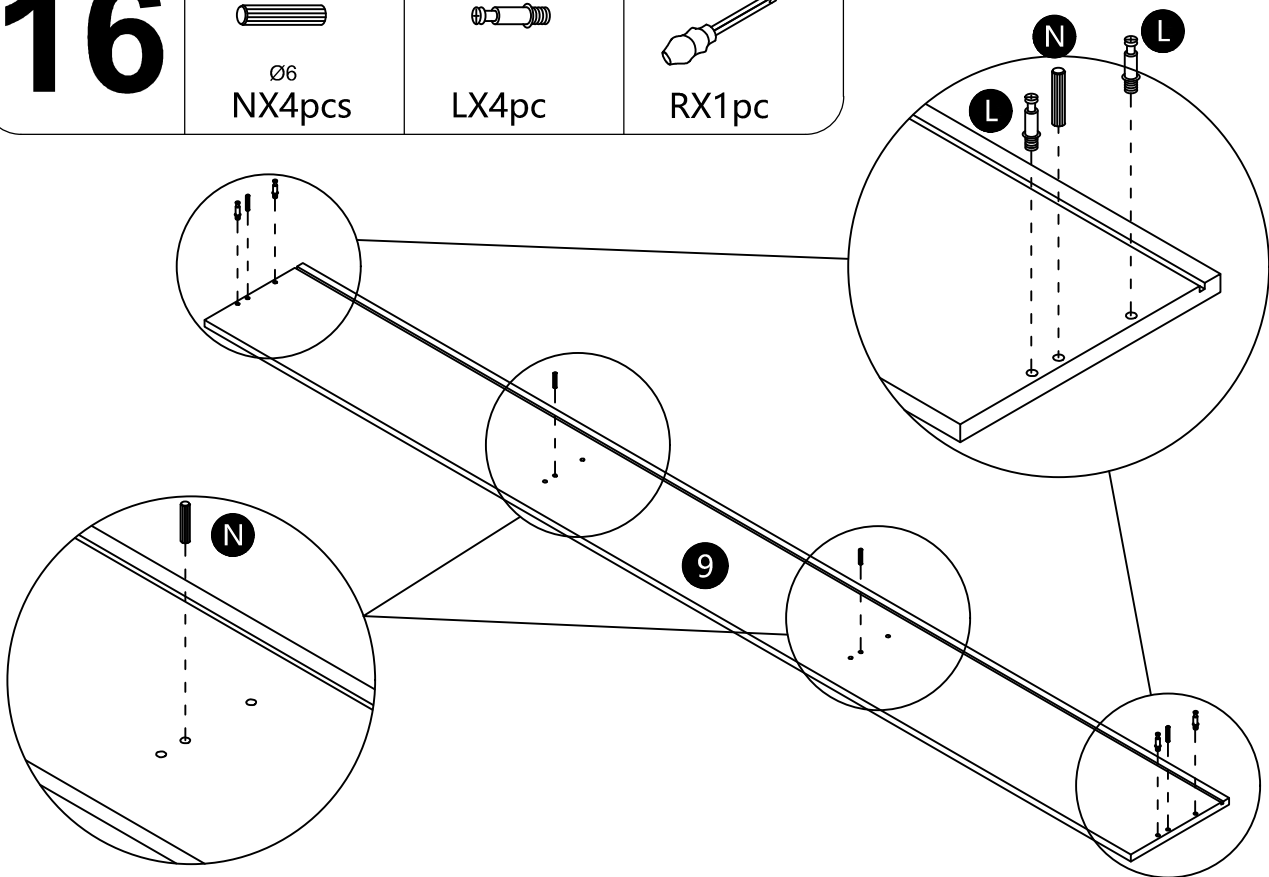

# 17

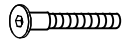

M5\*35  
KX8pcs



M5  
OX1pc



MX8pcs

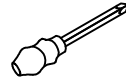

RX1pc

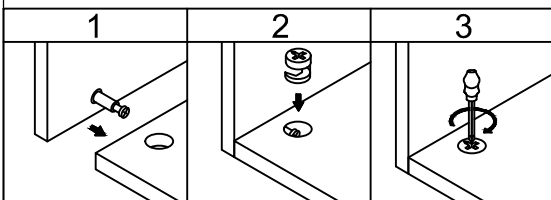
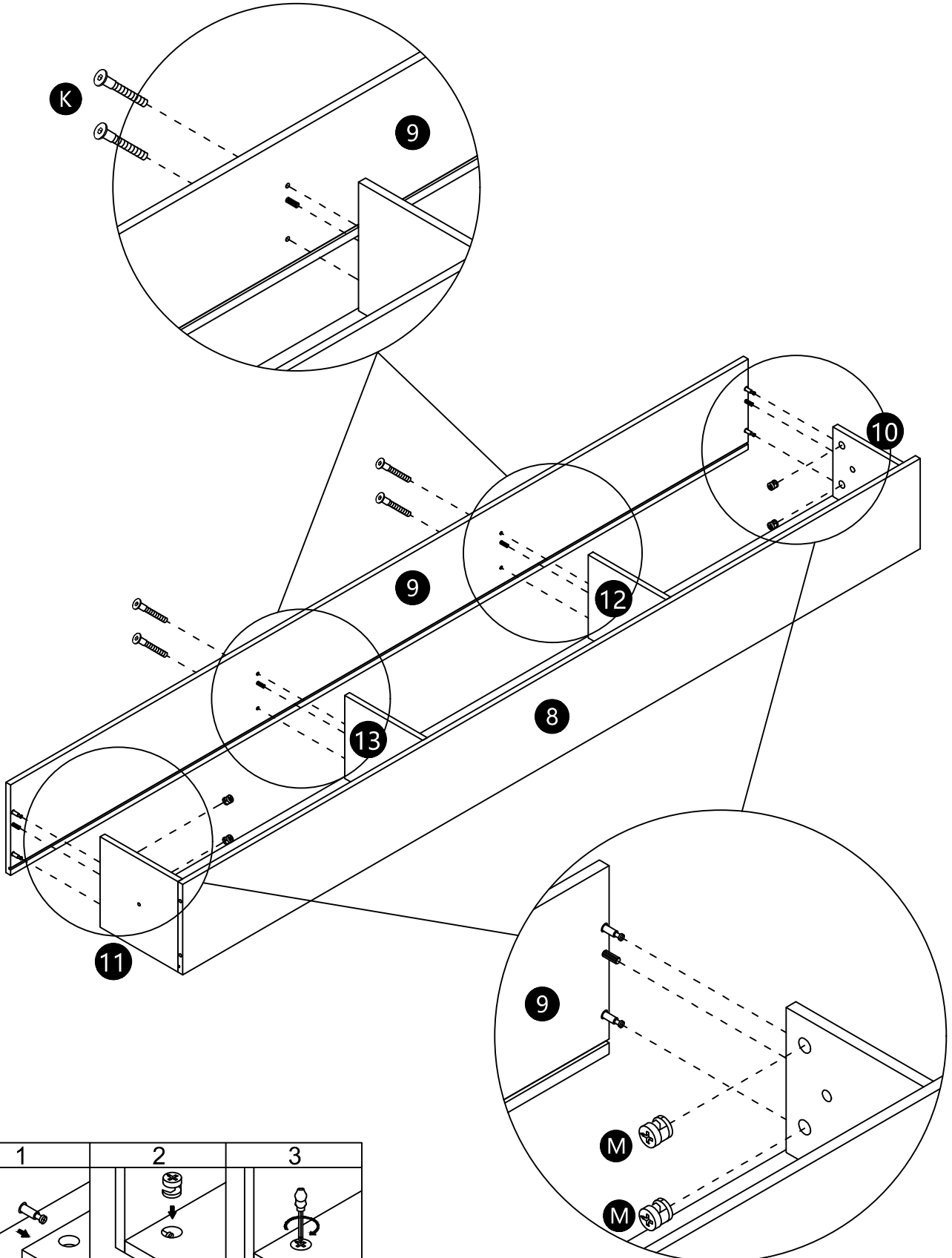

# 18

M6\*10  
AX4pcs

M6  
PX1pc

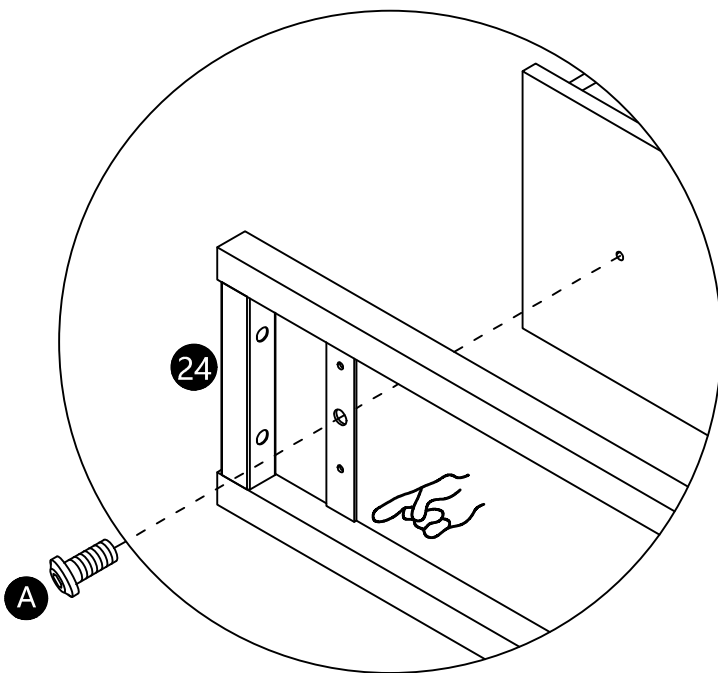
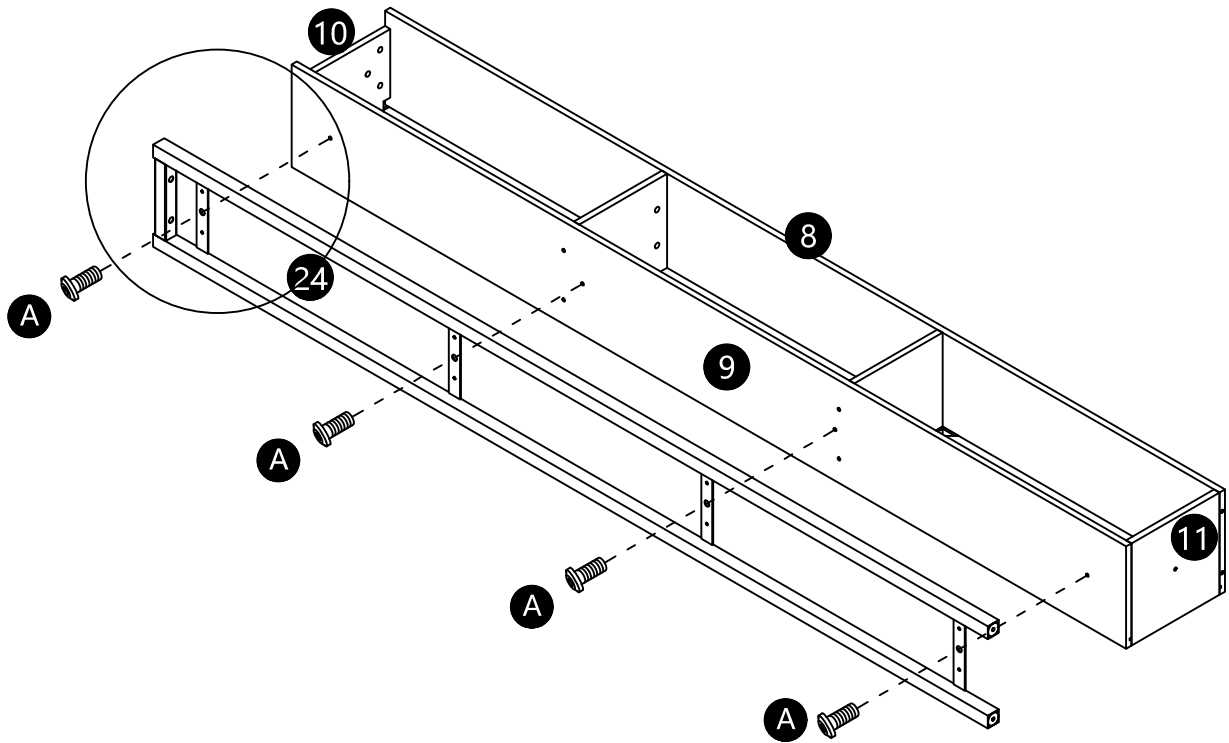

- \*Mind the position of the iron plate.
- \*Achten Sie auf die Position der Eisenplatte.
- \*Attention à la position de la plaque de fer.
- \*Tenga en cuenta la posición de la placa de hierro.
- \*Prestate attenzione alla posizione della piastra di ferro.

# 19



M6\*33  
BX1pcs



M6\*45  
CX2pcs



M6  
PX1pc

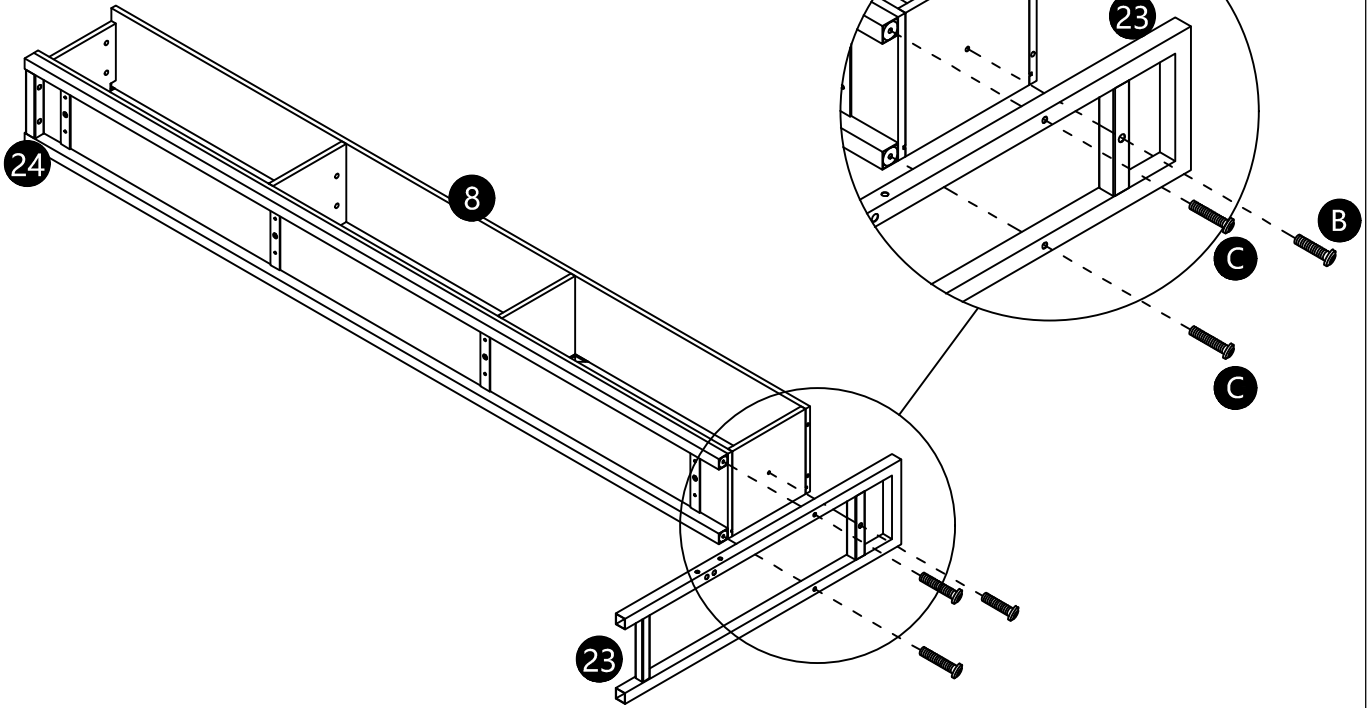

# 20



Ø6  
NX3pcs

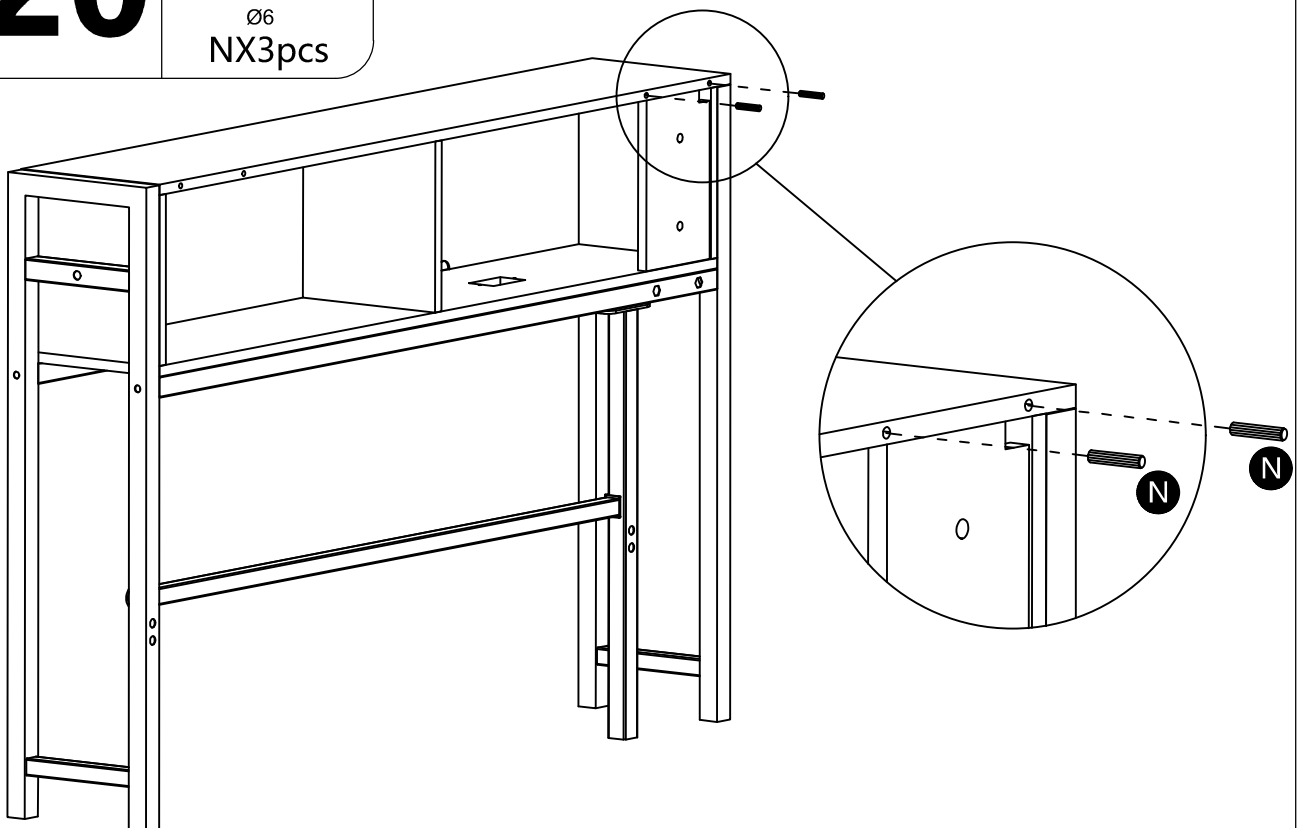

# 21



M8\*23  
FX2pcs



M8\*55  
HX2pcs

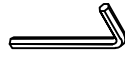

M8  
QX1pc

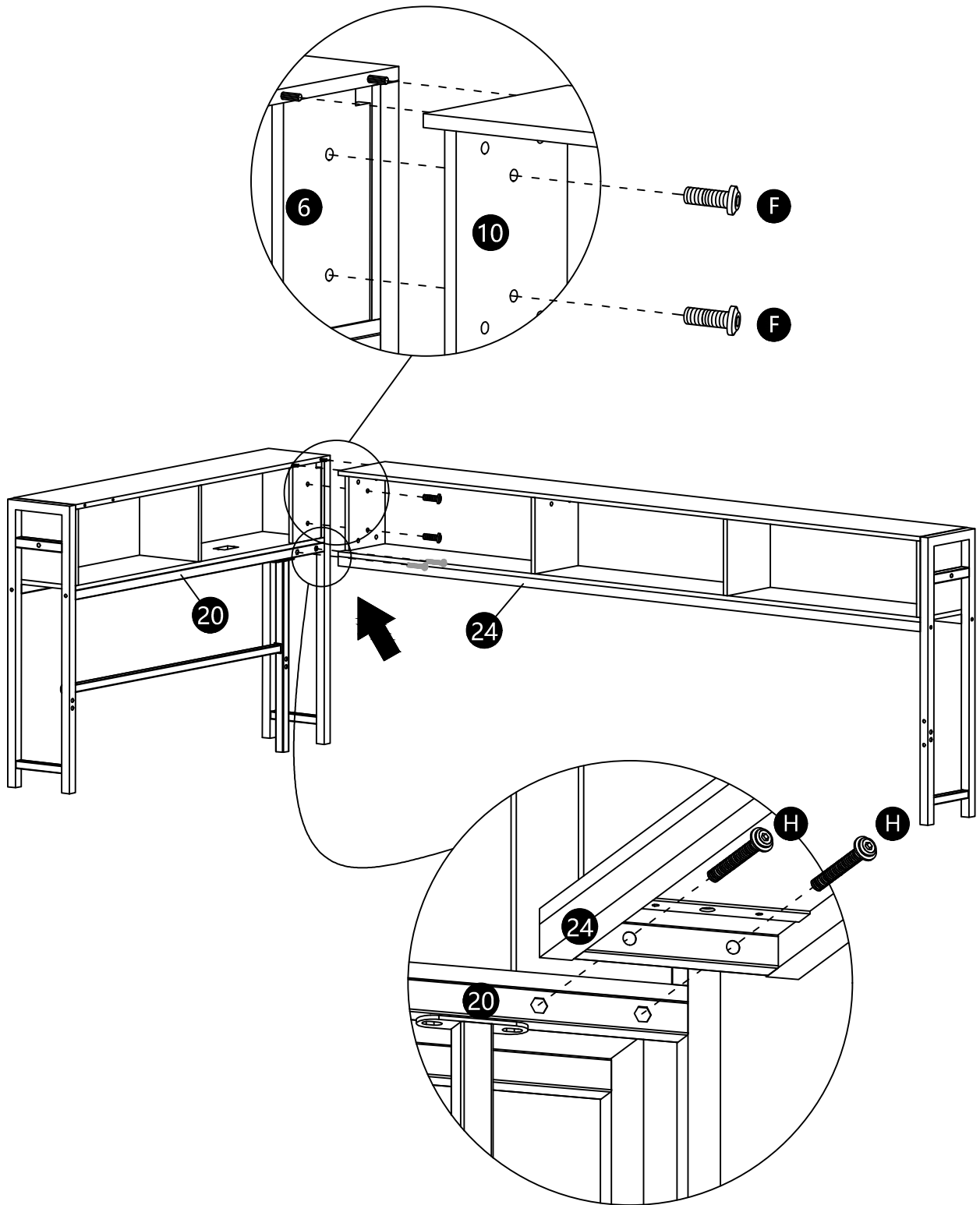

# 22



M8\*55  
HX4pcs



M8  
QX1pc

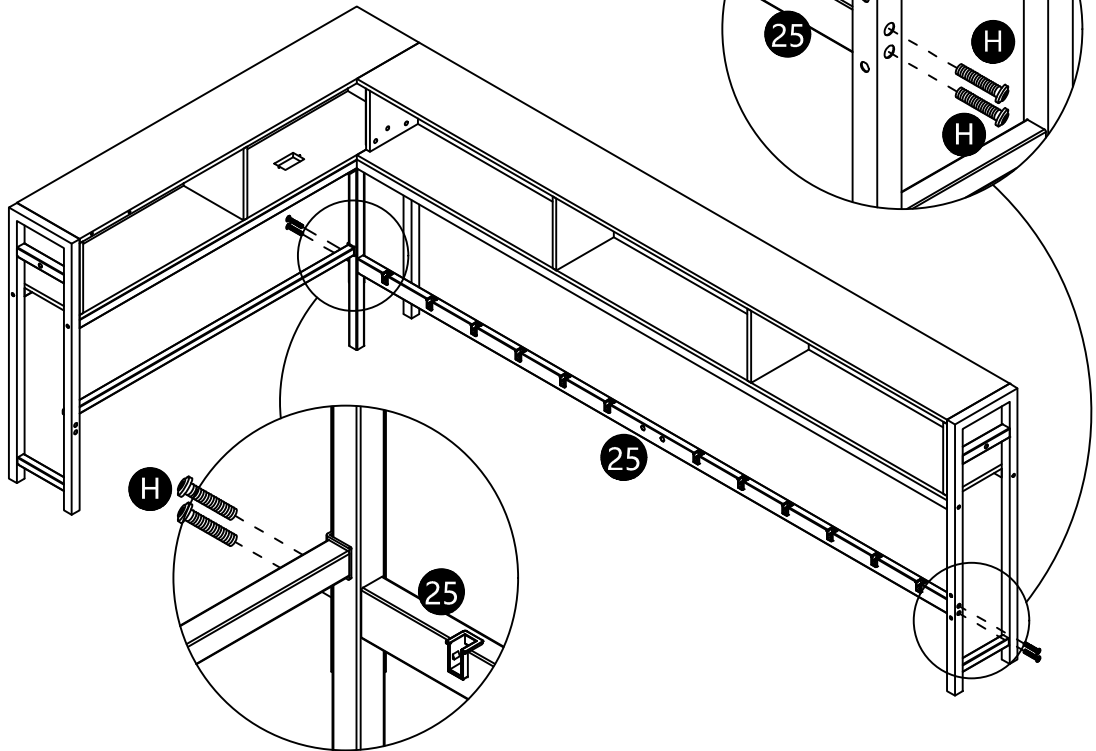

# 23



M8\*20  
EX2pcs



M8  
QX1pc

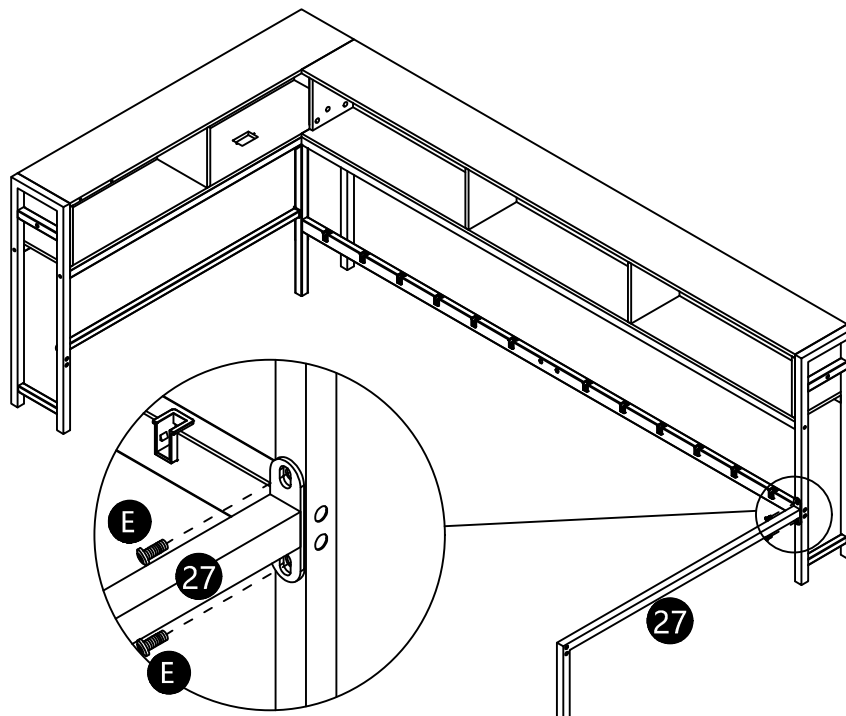

# 24



M8\*55  
HX4pcs



M8  
QX1pc

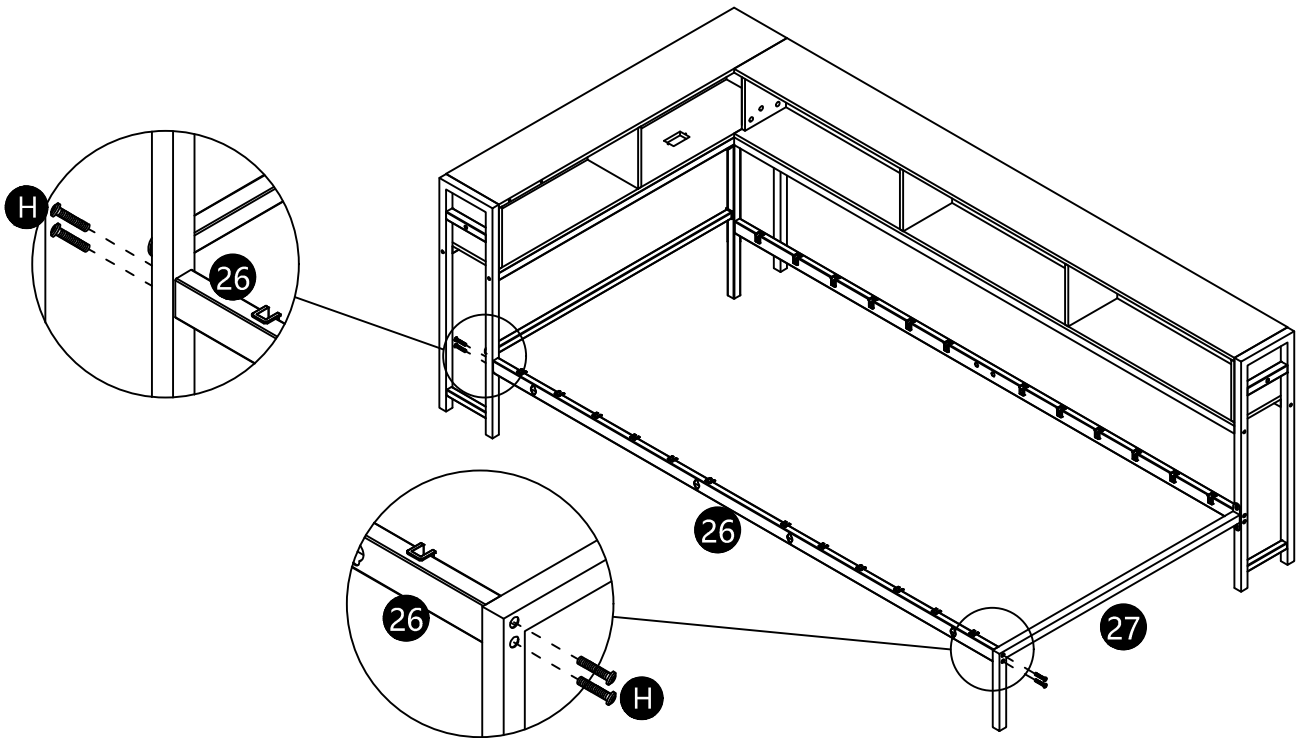

# 25



M3\*12  
JX2pcs

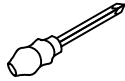

RX1pc

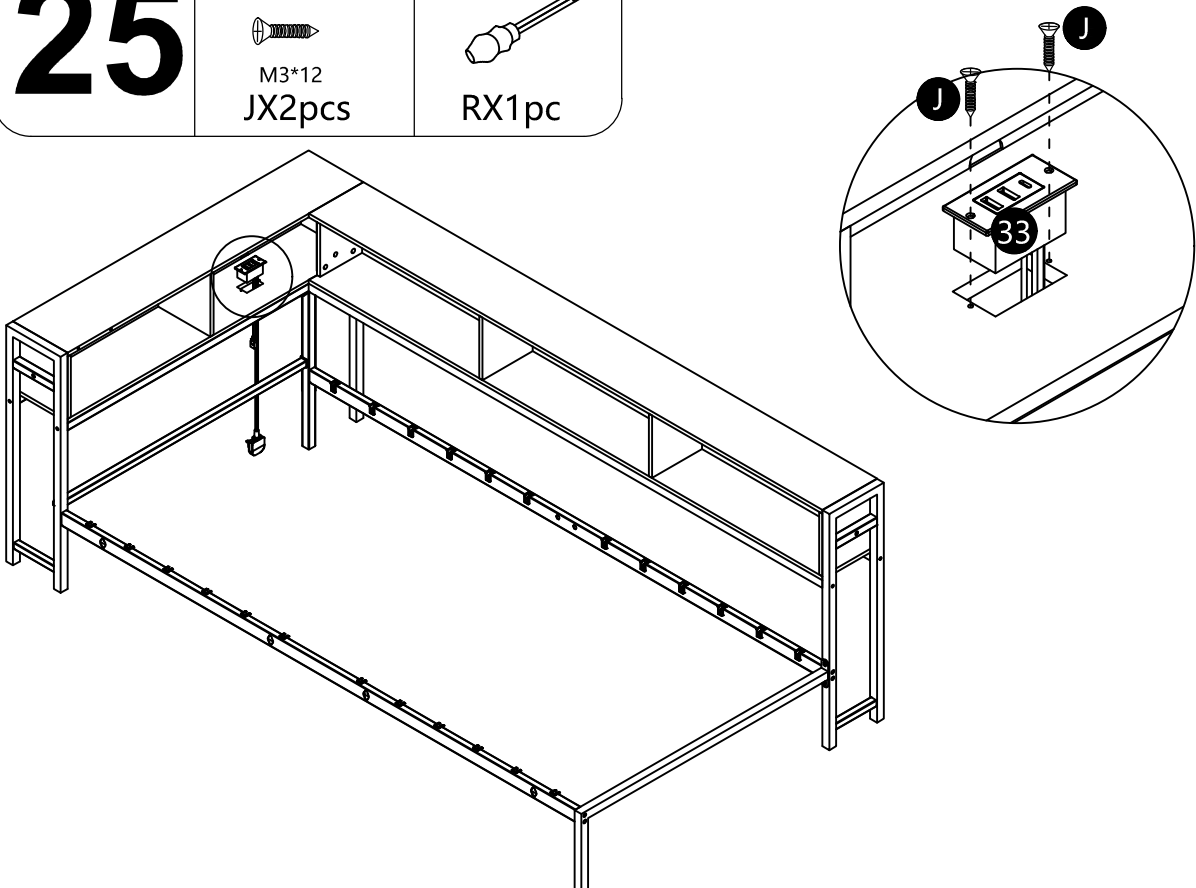

# 26

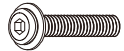

M8\*35  
GX4pcs

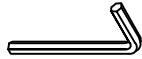

M8  
QX1pc

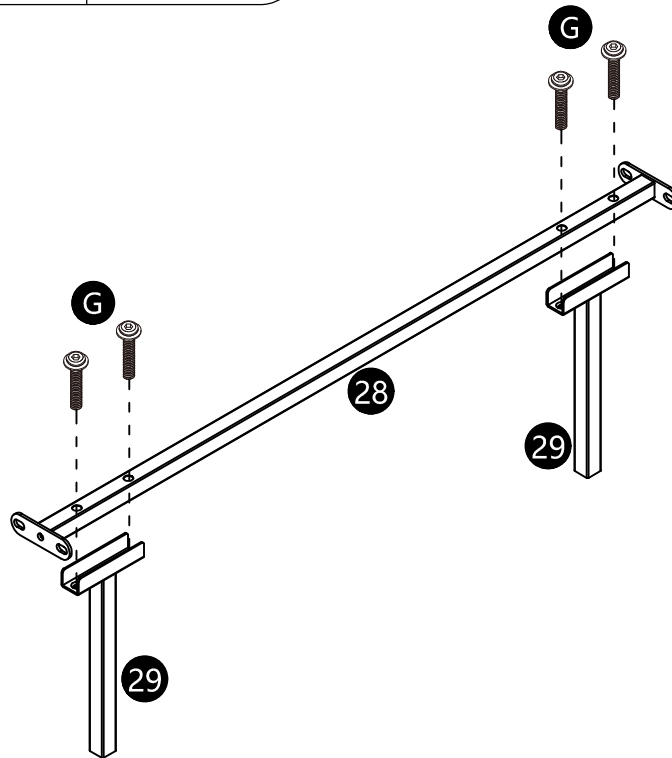

# 27



M8\*20  
EX4pcs

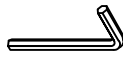

M8  
QX1pc

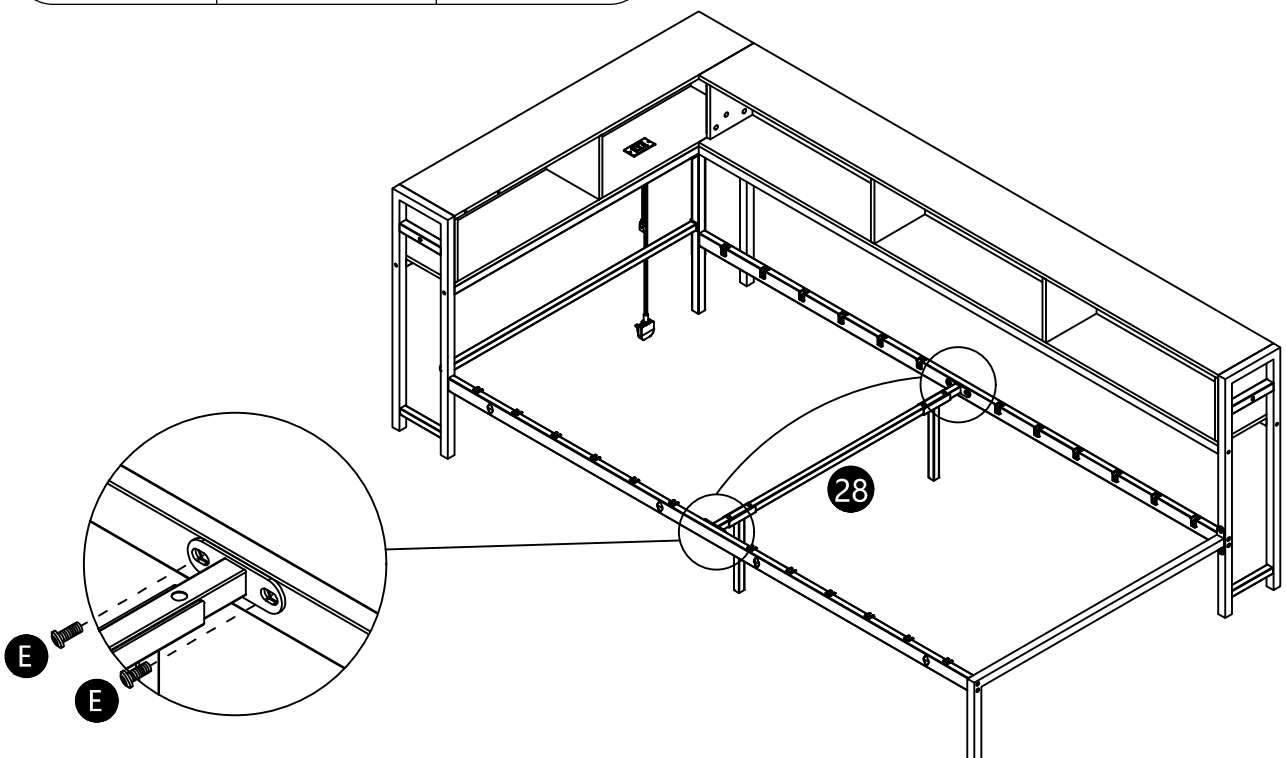

28

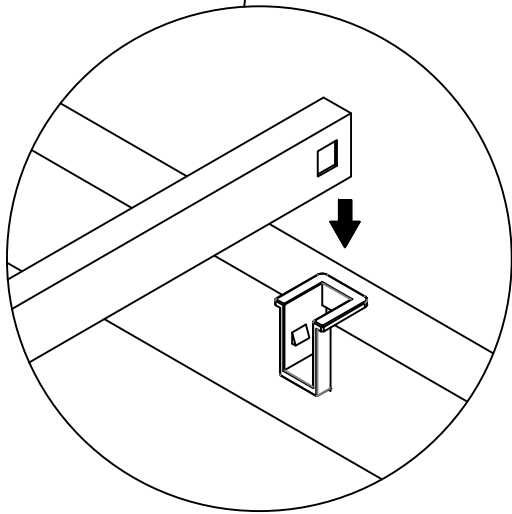
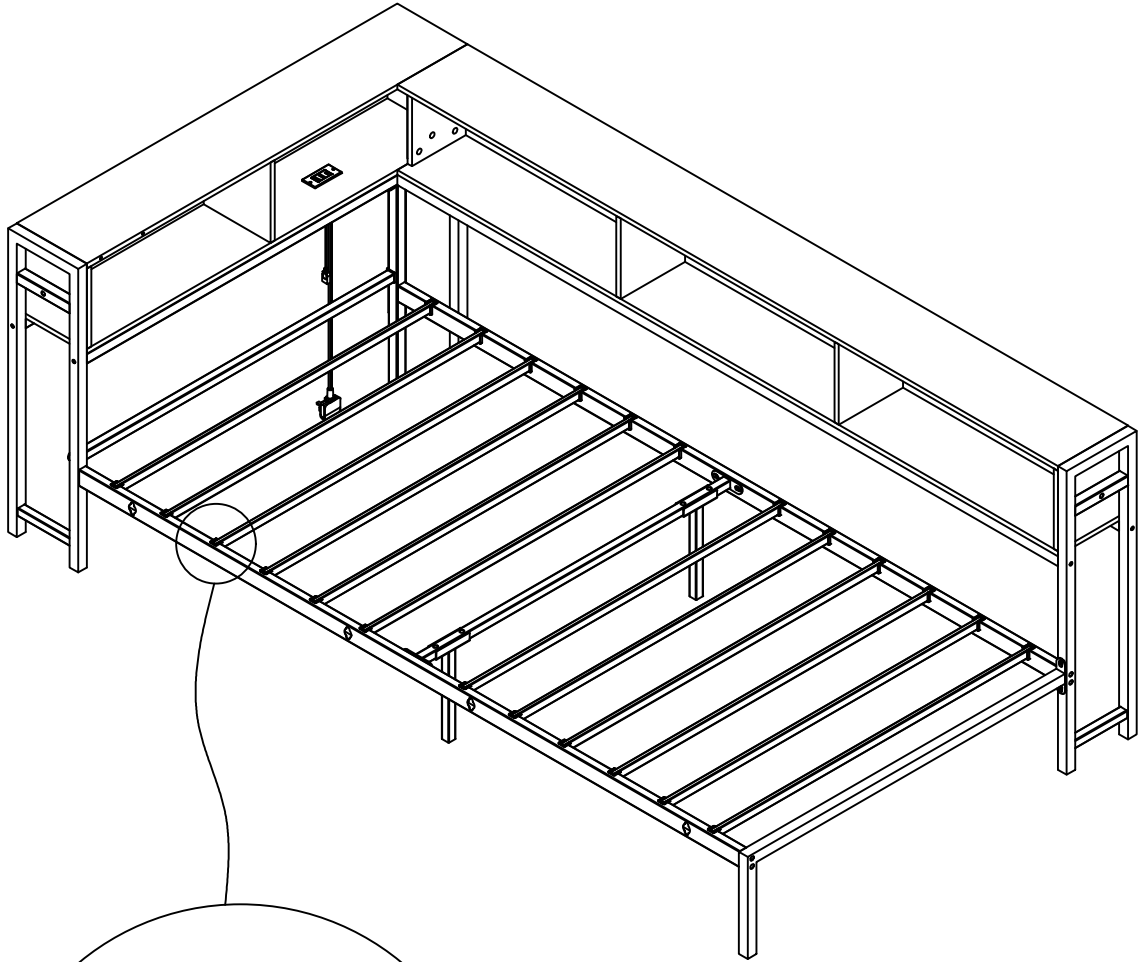

30 x12

# 29

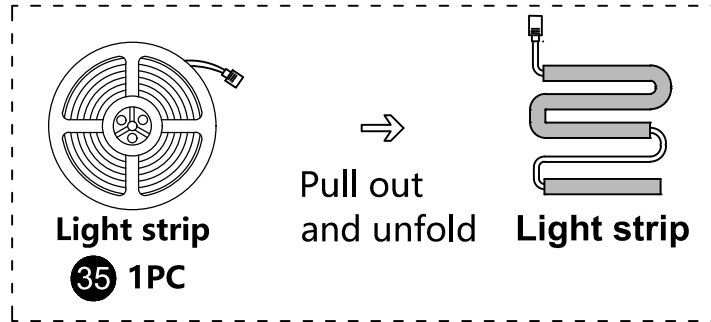

\*Stick the light strip onto the Velcro on the inner side of the bedside cabinet.

\*Kleben Sie den Lichtstreifen auf den Klettverschluss auf der Innenseite des Bettschranks.

\*Collez la bande de lumière sur le velcro sur le côté intérieur de l'armoire de chevet.

\*Ponga la tira de luz en el velcro en el lado interior del gabinete de cama.

\*Incollare la striscia di luce sul velcro sul lato interno del comodino.

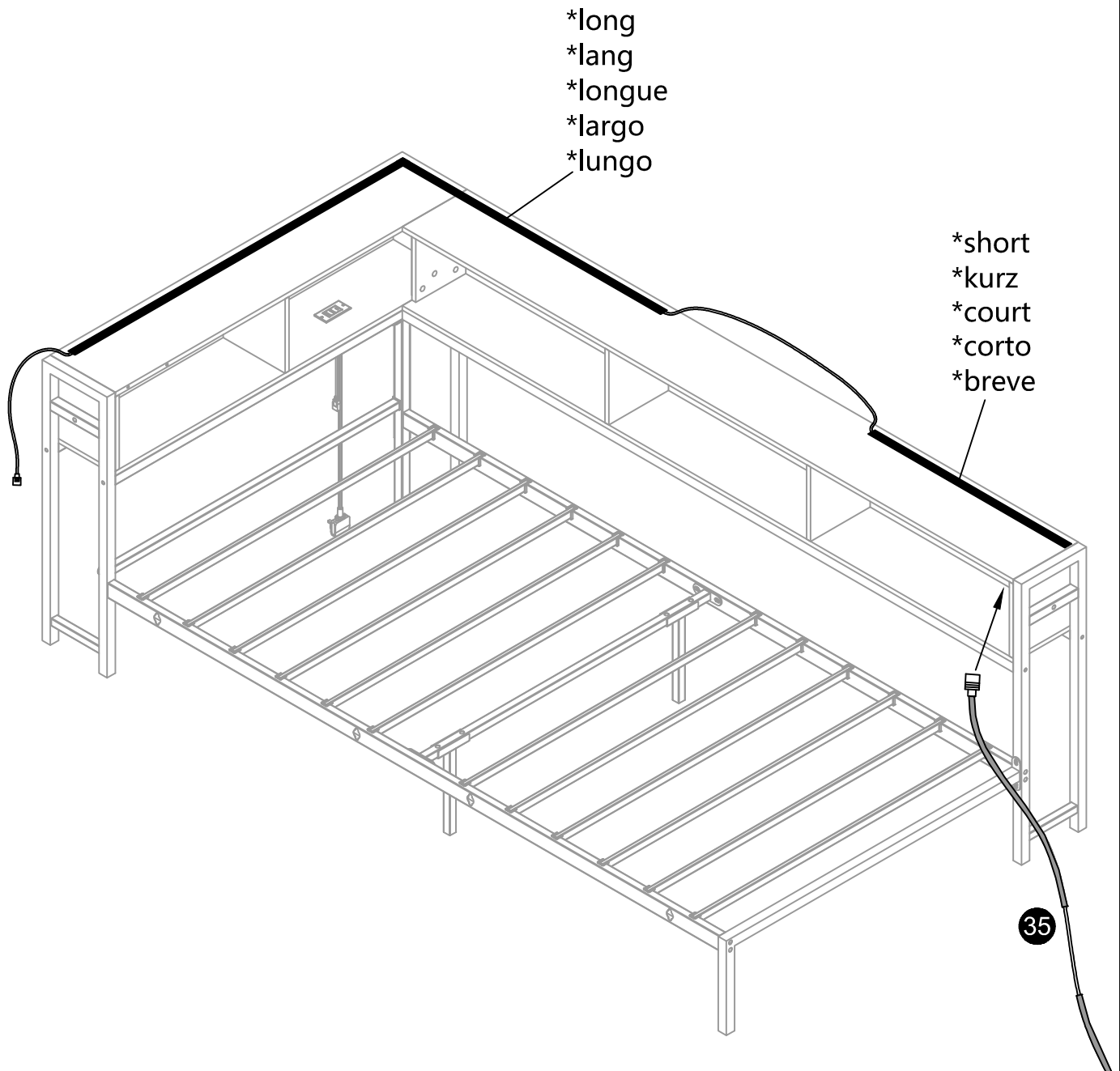

**30**



Magic tape  
SX2pcs

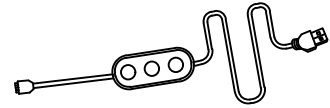

**36** Power cord  
1PC

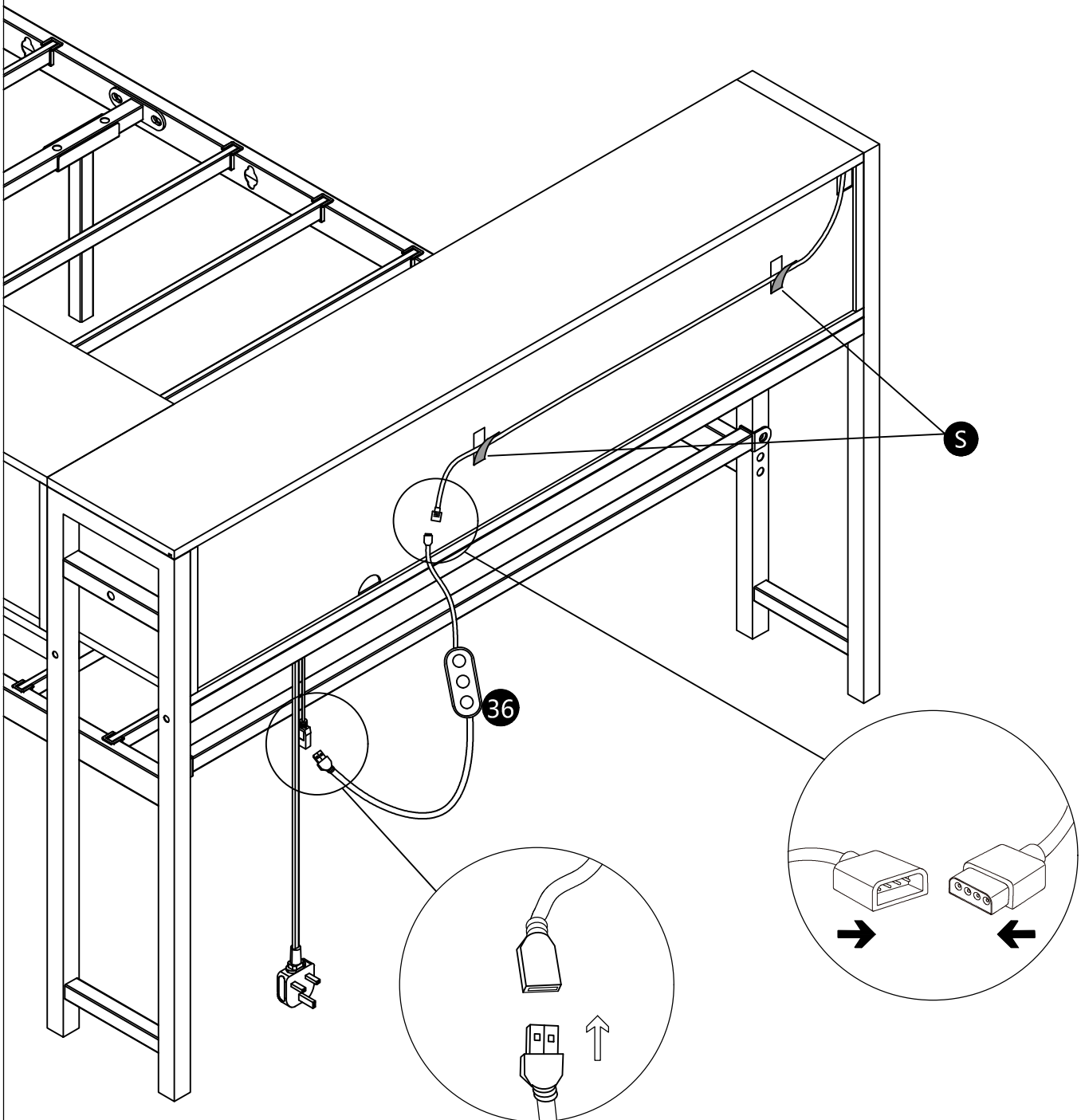

31

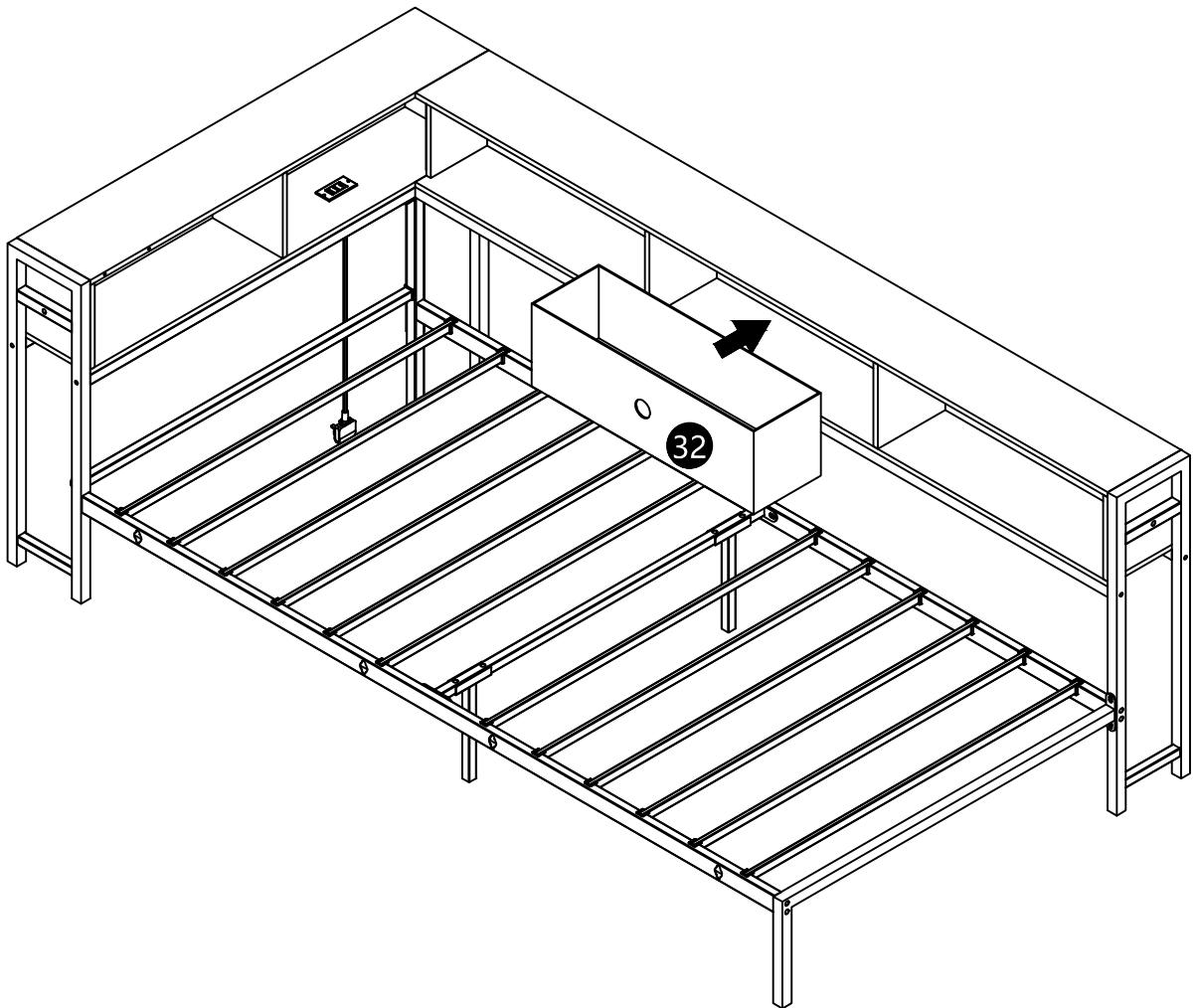

# 32



UX4pcs

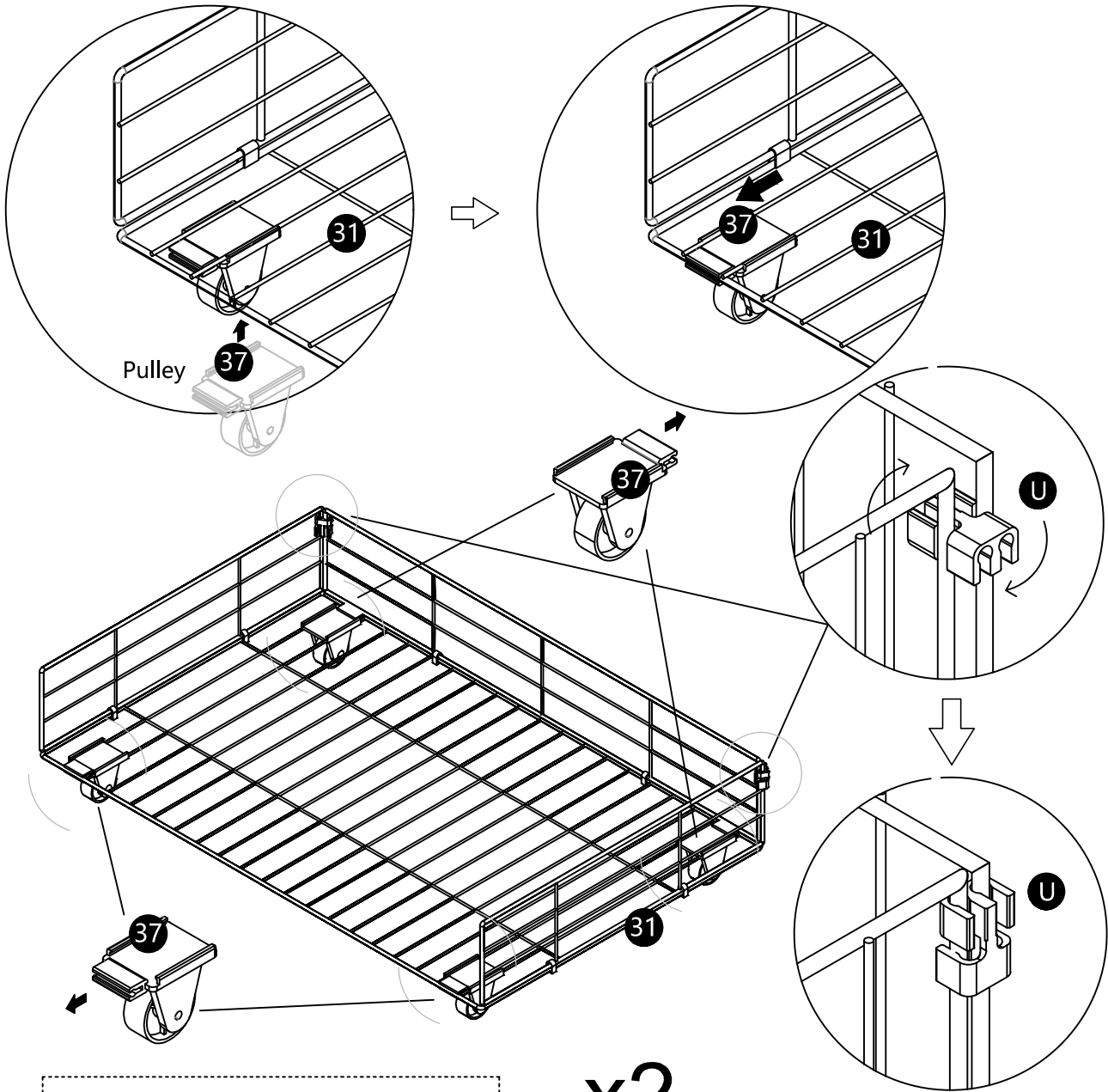

x2

Pulley

Pulley

**Pay attention to the orientation before clamping in**

**Please note that this drawer base (31) has front and back sides! Please see the instructions clearly before assembling!!!**

# 33

M8\*10  
DX10pcs

M8  
QX1pc

TX6pcs

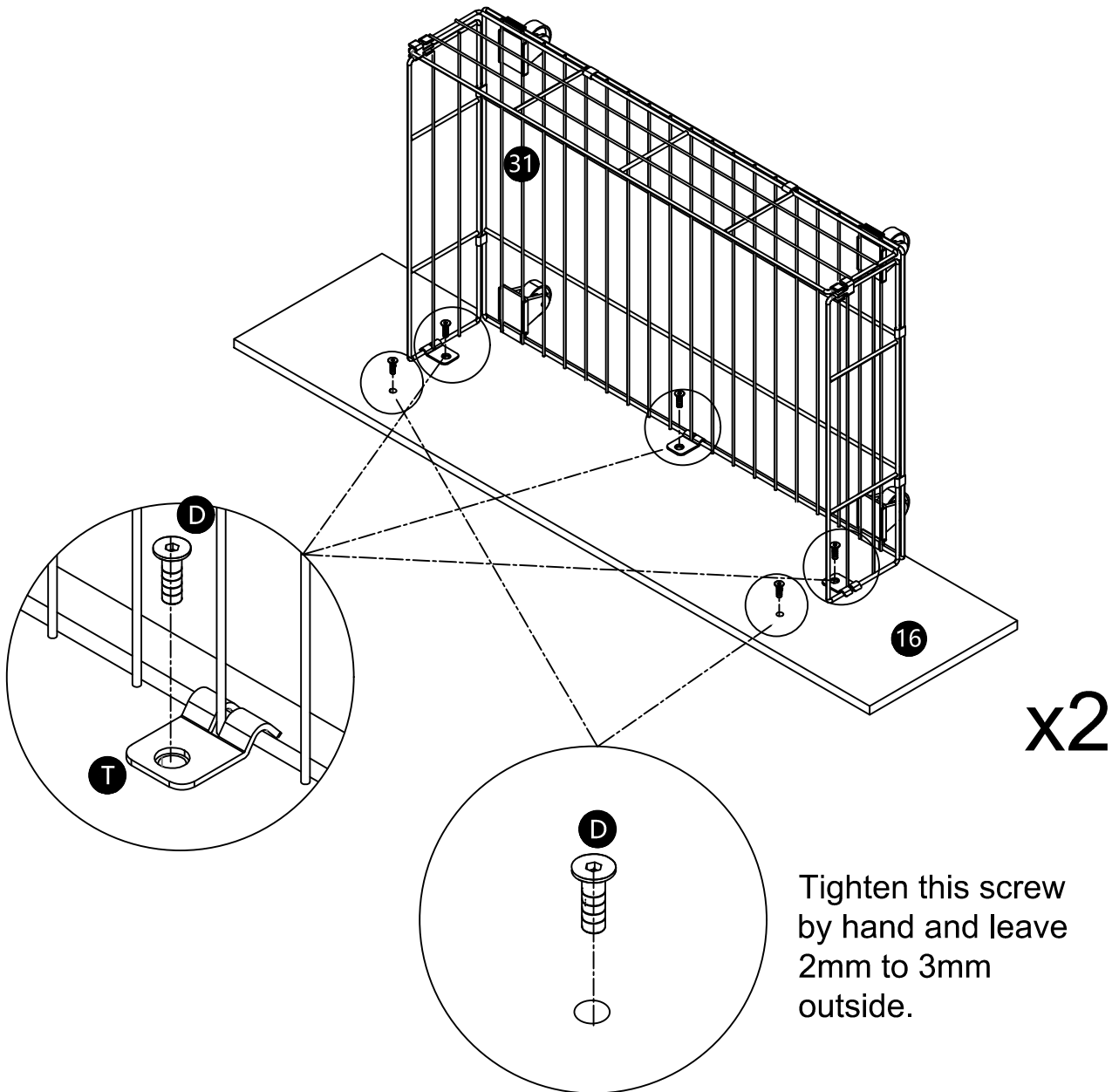

# 34

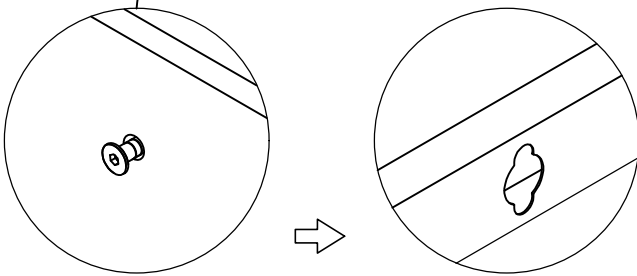
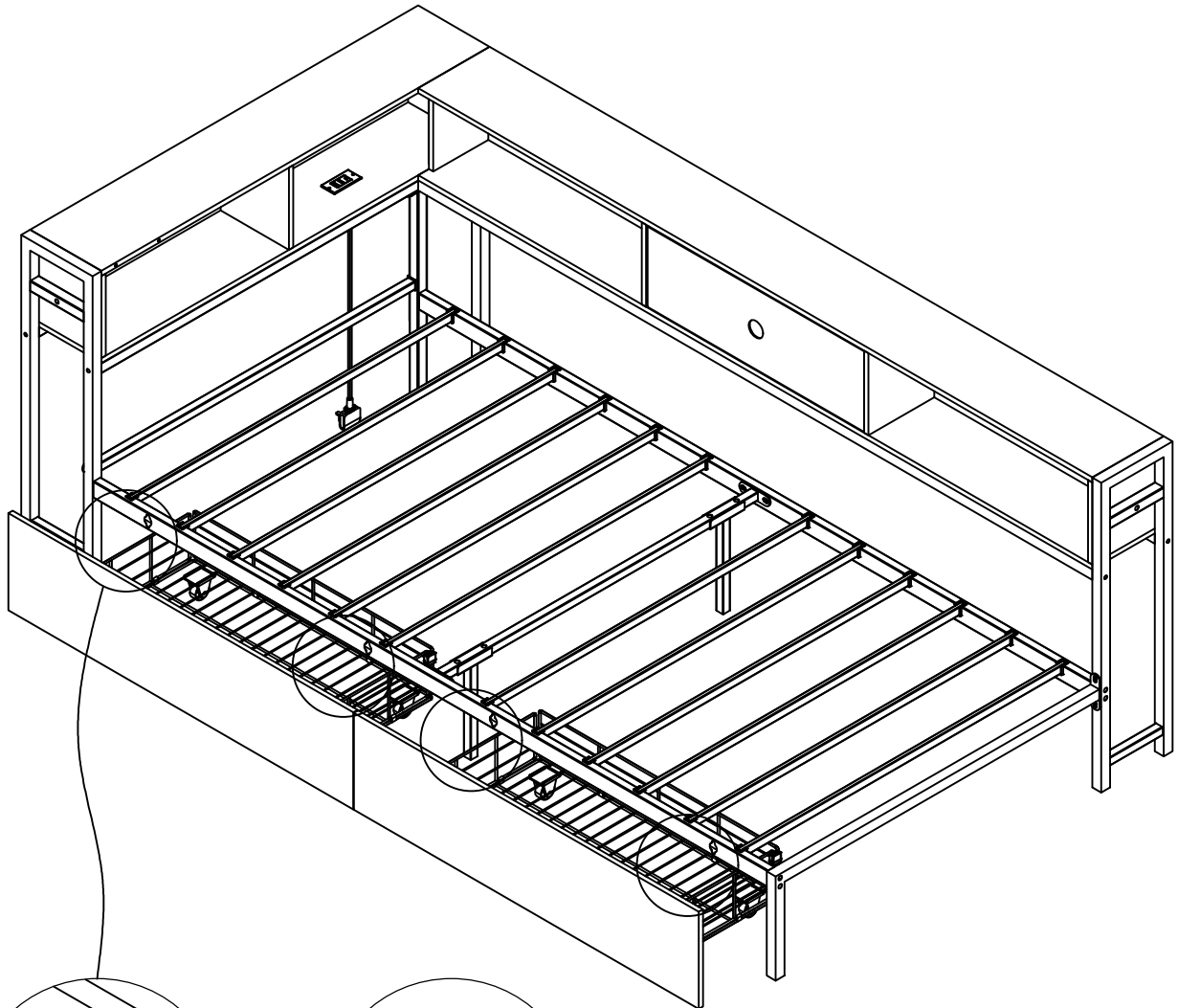

When pushing into the drawer, Lift the drawer gently,  
Align the screw with the gourd hole and push in  
When pulling out the drawer, Lift the drawer gently,  
Align the screw with the gourd hole, and then pull it out

# 2.

- \*Assembly Method 1
- \*Montagemethode 2
- \*Méthode d'assemblage 2
- \*Método de montaje 2
- \*Metodo di assemblaggio 2

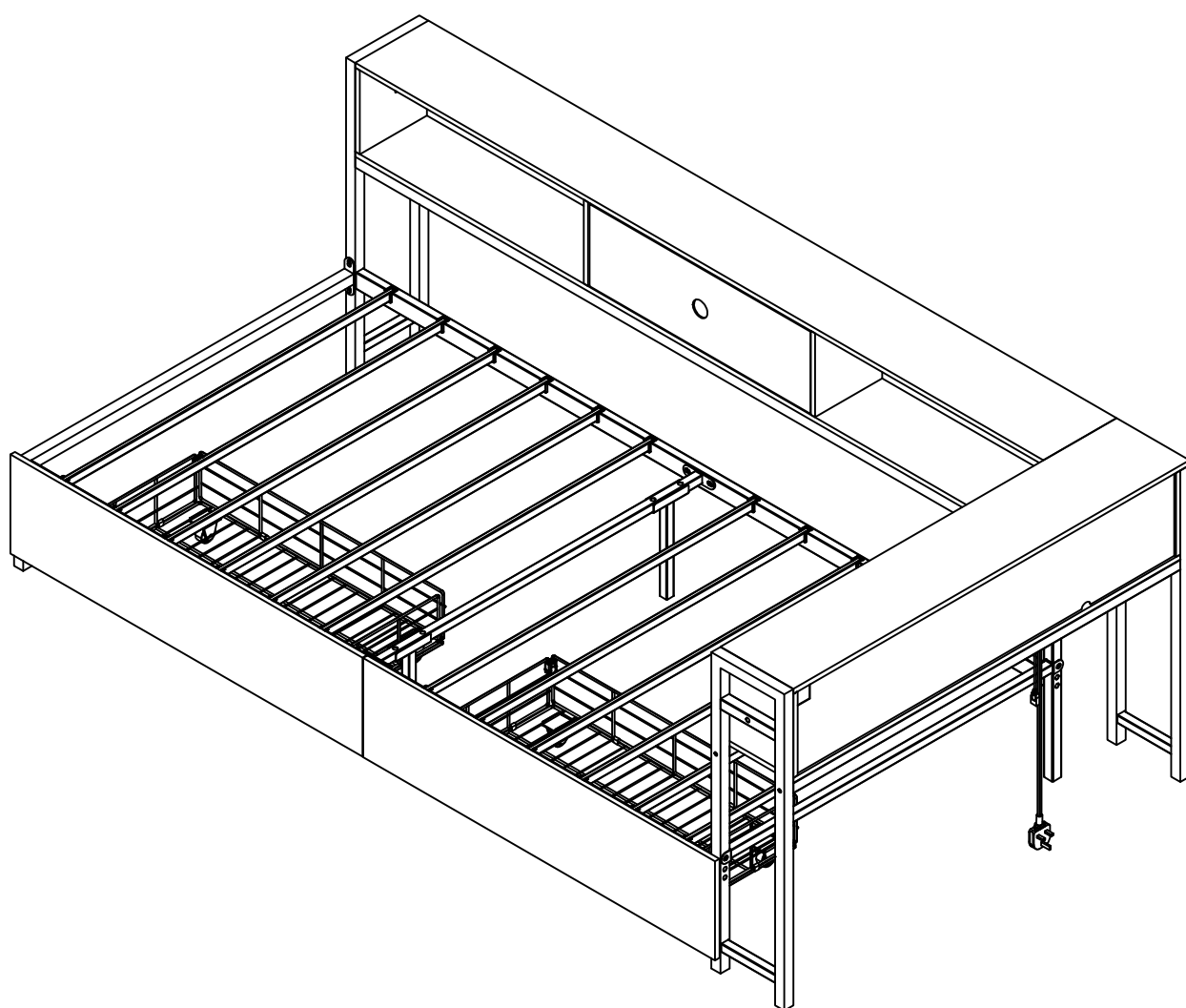

# 1

Ø6  
NX3pcs

LX6pc

RX1pc

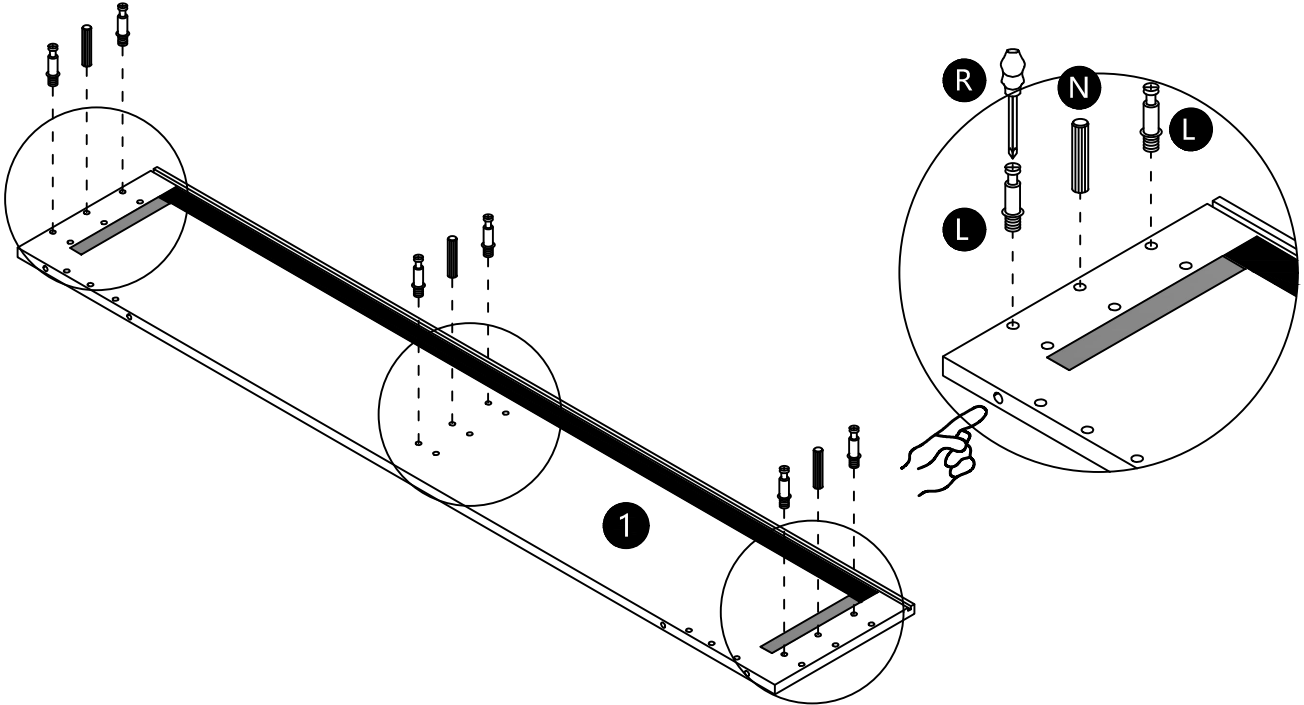

# 2

MX6pcs

RX1pc

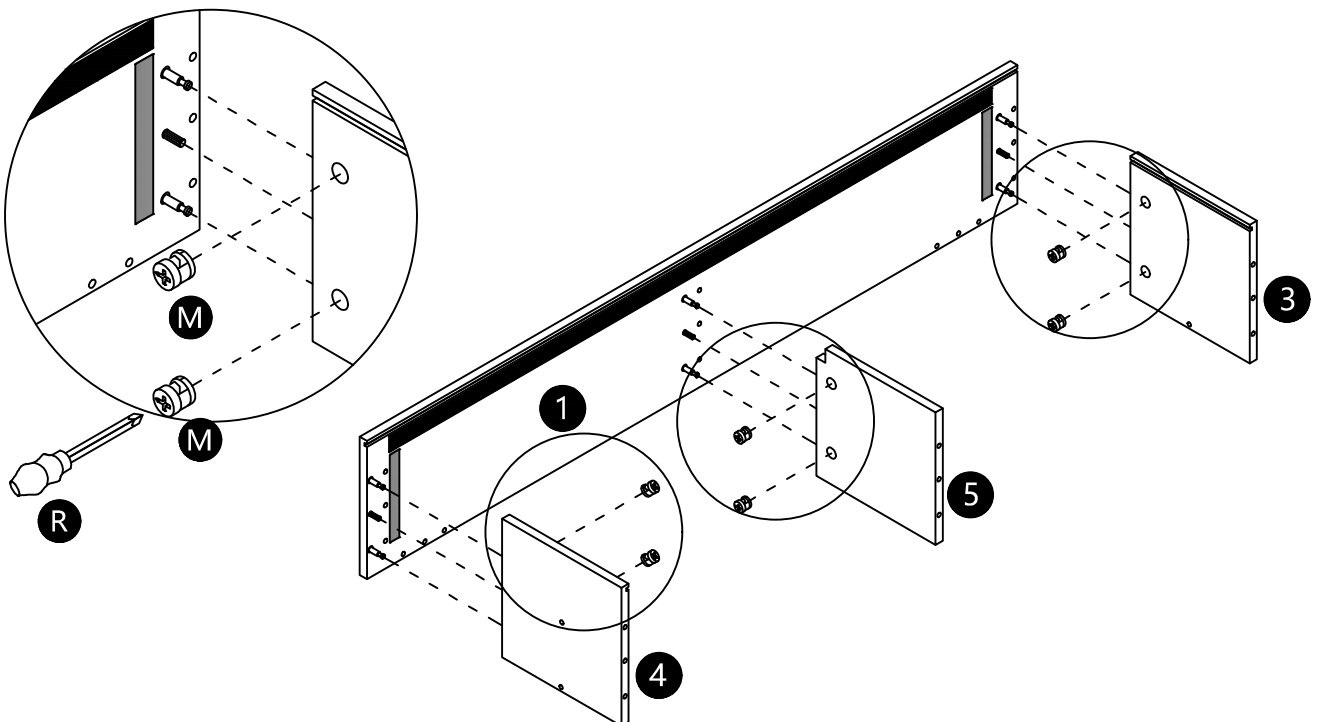
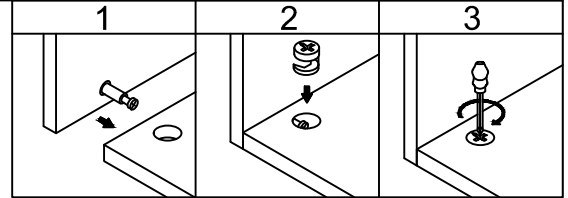

# 3



Ø6  
NX1pcs



LX2pc

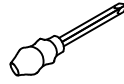

RX1pc

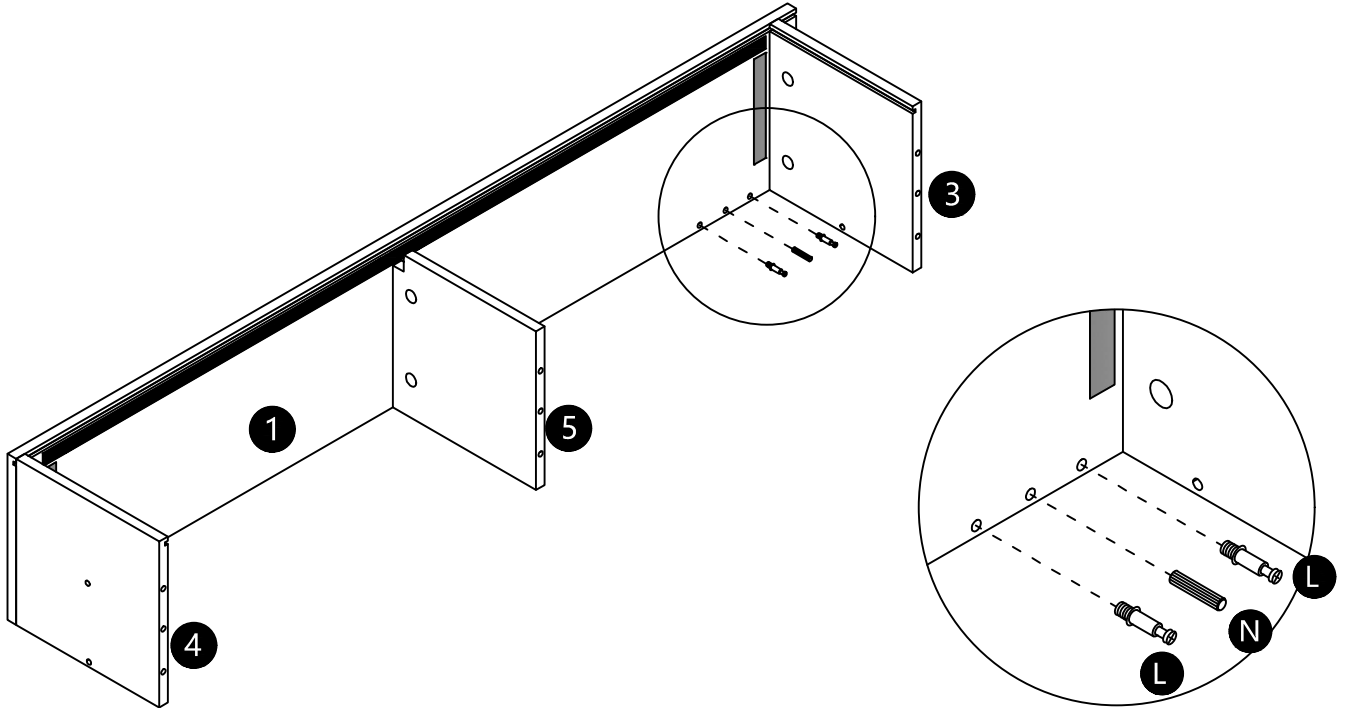

# 4



MX2pcs



RX1pc

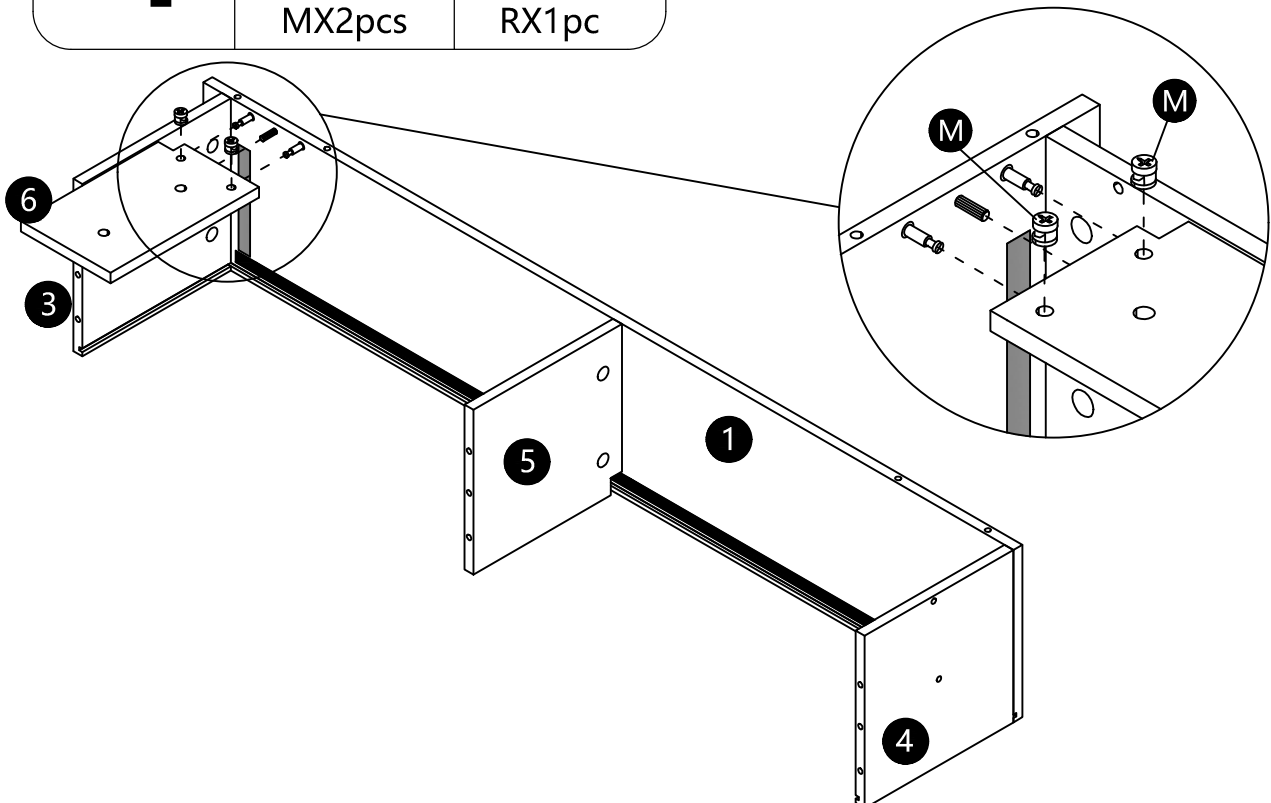
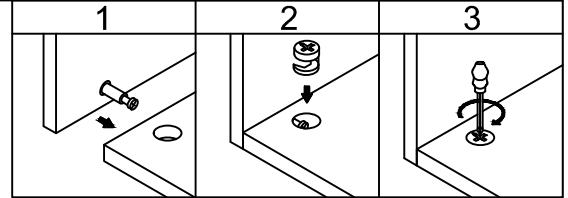

# 5

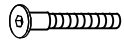

M5\*35  
KX1pcs

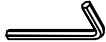

M5  
OX1pc

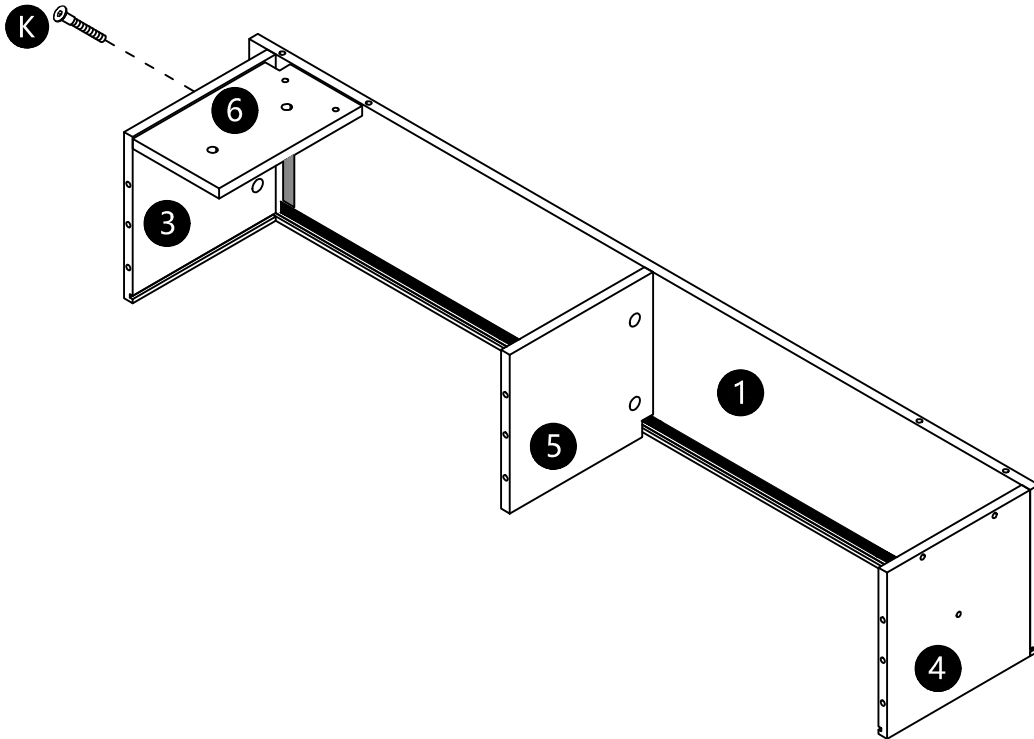

# 6

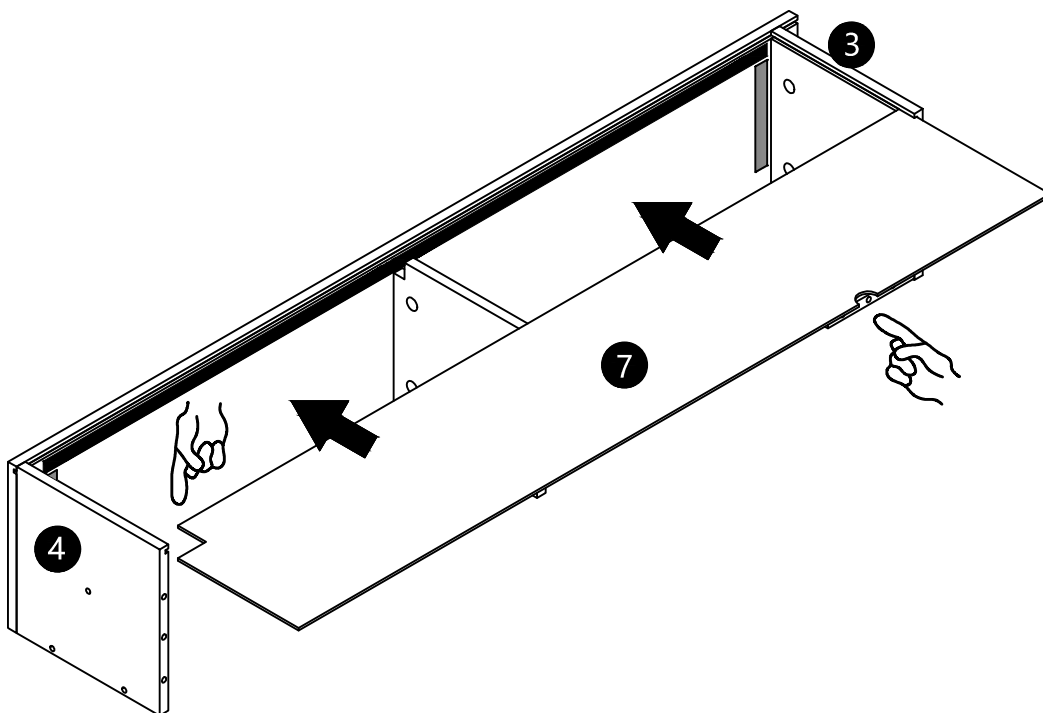

7



Ø6  
NX4pcs

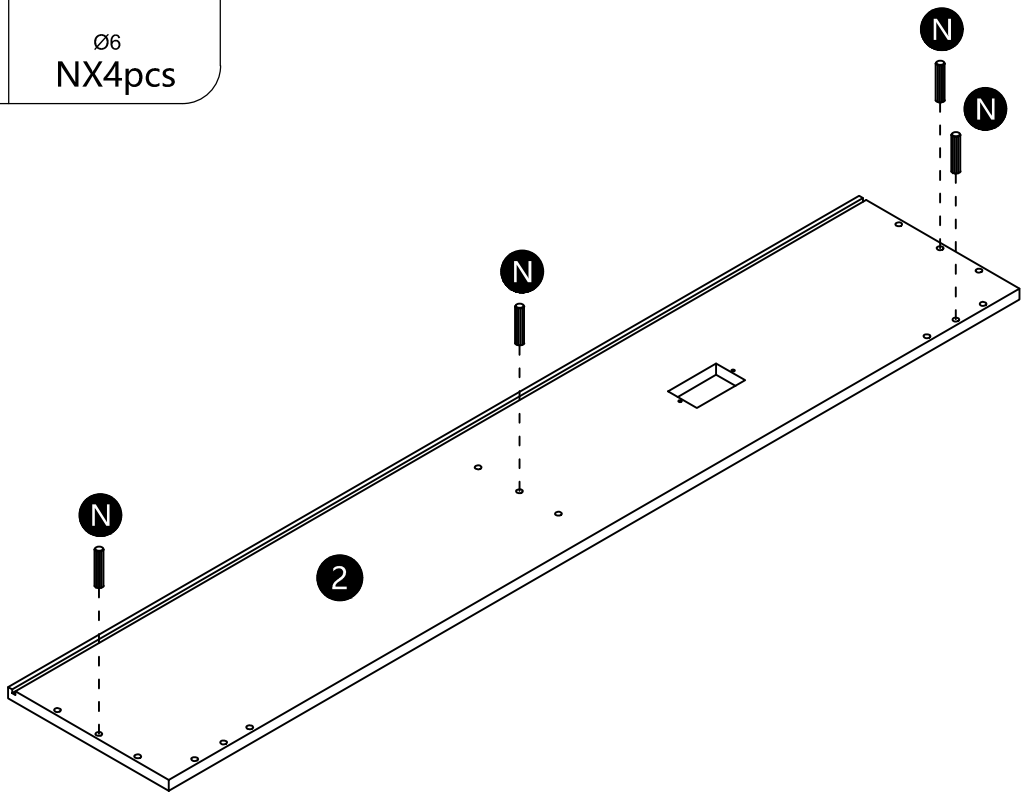

8

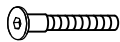

M5\*35  
KX8pcs



M5  
OX1pc

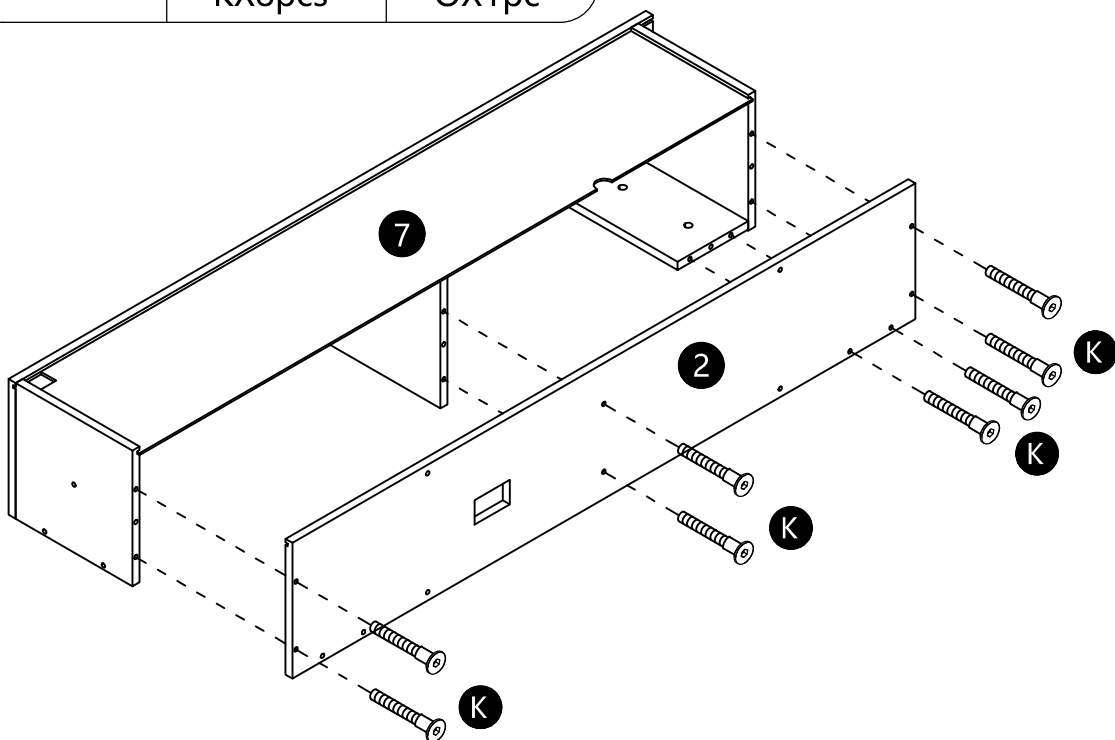

# 9

M6\*33  
BX4pcs

M6  
PX1pc

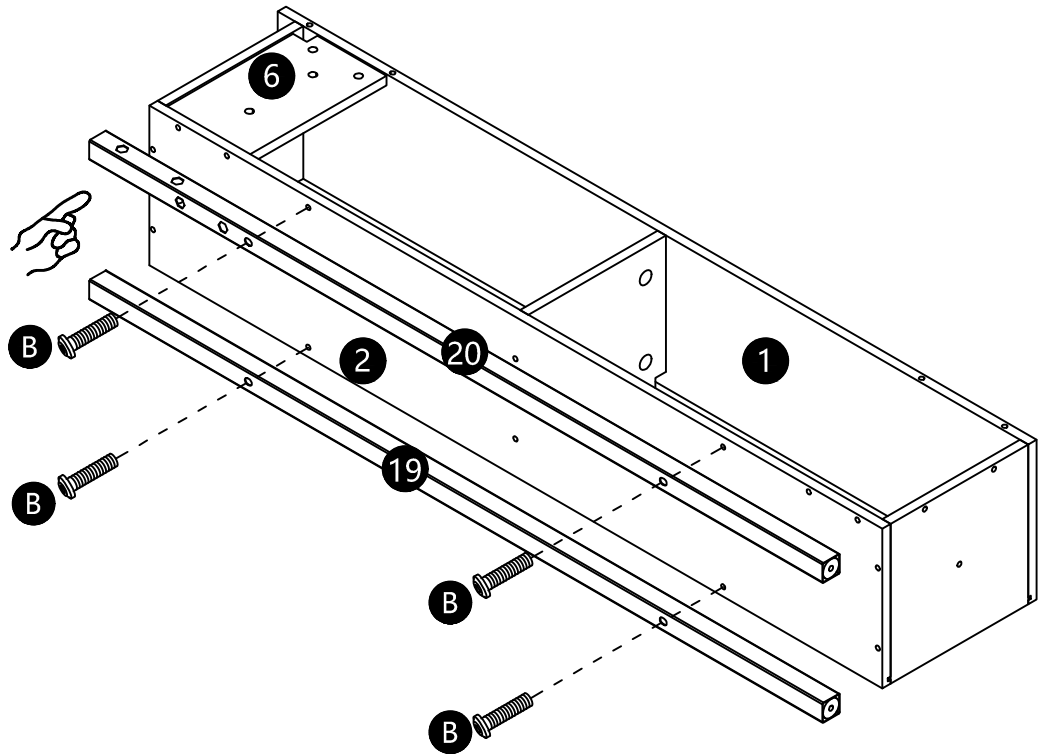

# 10

M6\*33  
BX2pcs

M6\*45  
CX4pcs

M6  
PX1pc

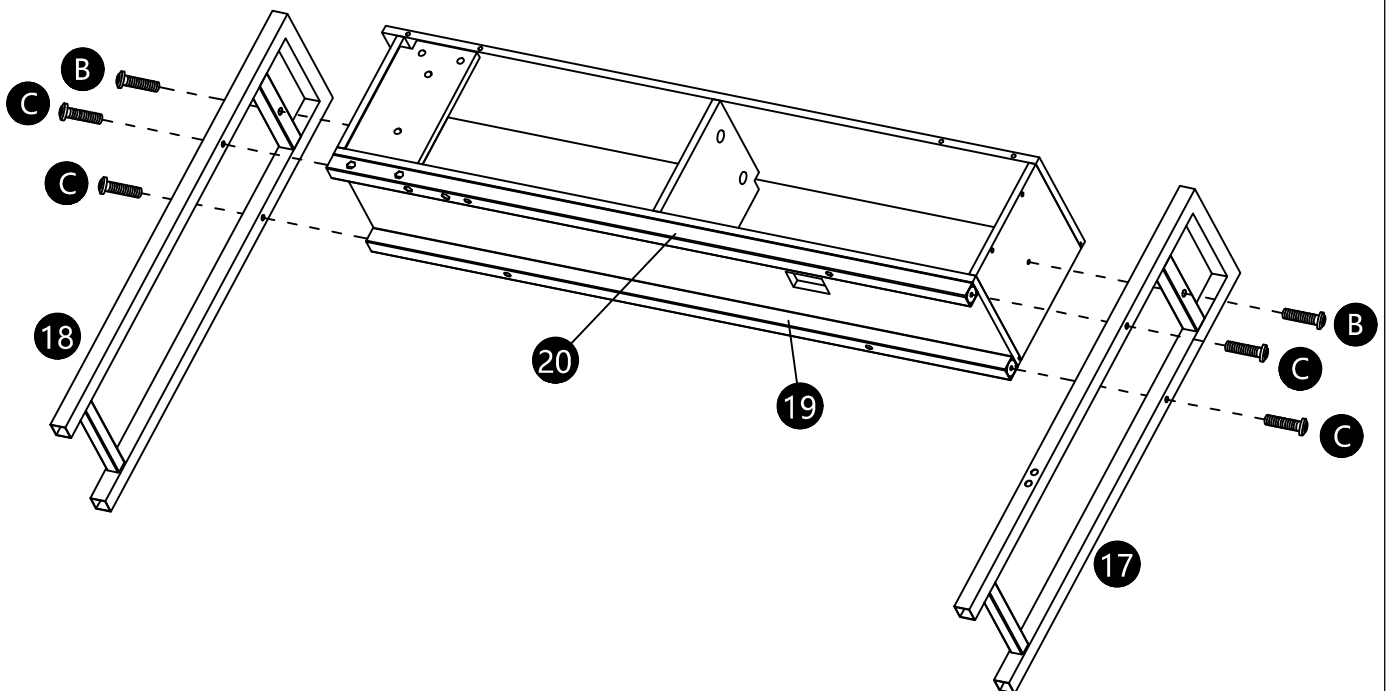

# 11

M8\*20  
EX2pcs

M8  
QX1pc

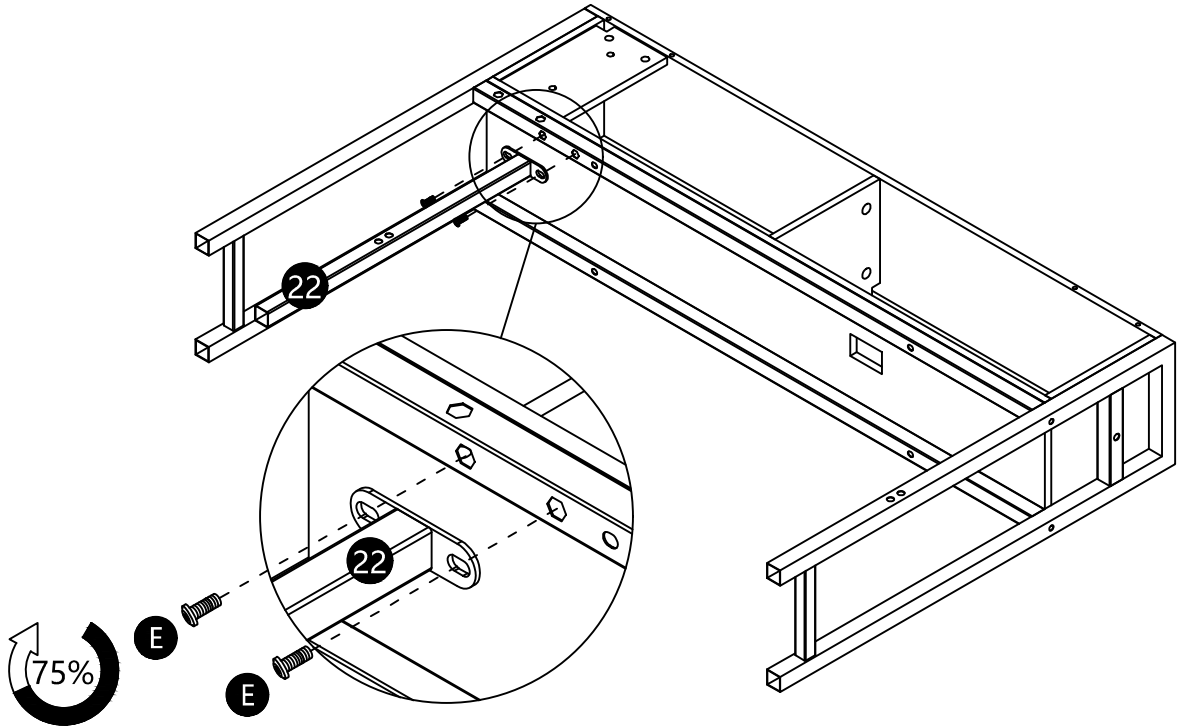

# 12

M8\*20  
EX2pcs

M8  
QX1pc

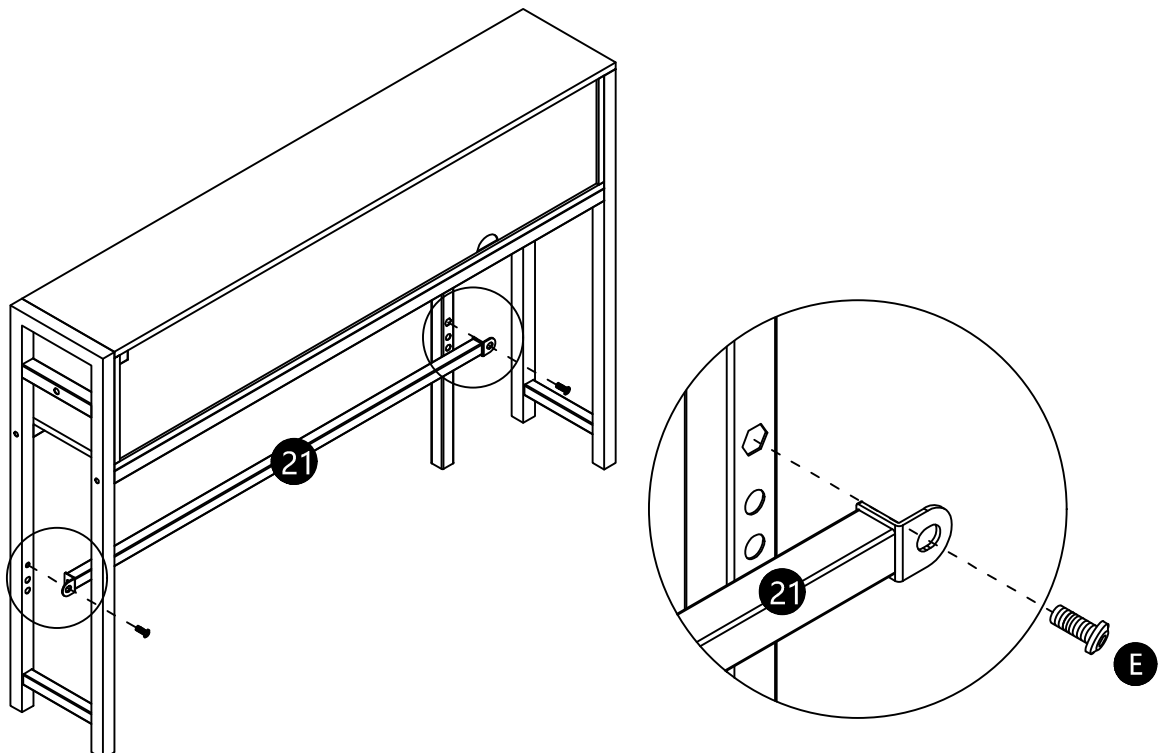

# 13



Ø6  
NX4pcs



LX8pcs

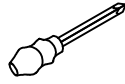

RX1pc

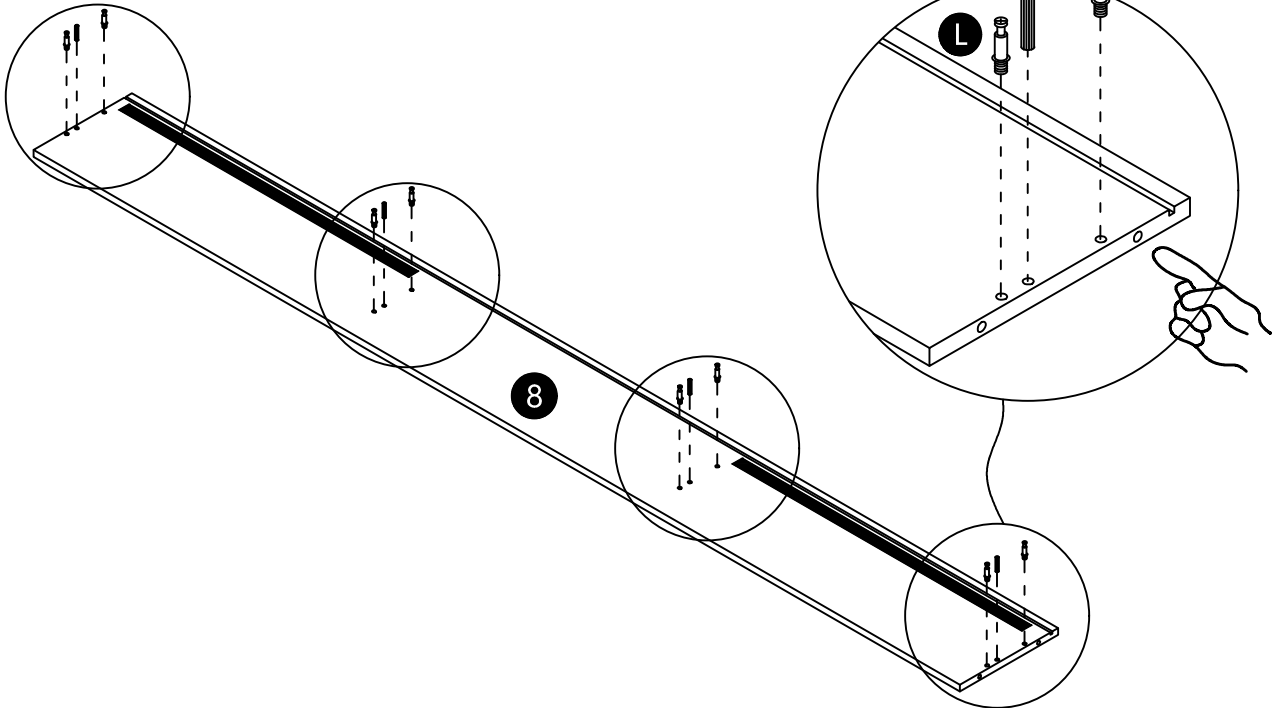

# 14



MX8pcs

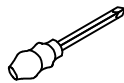

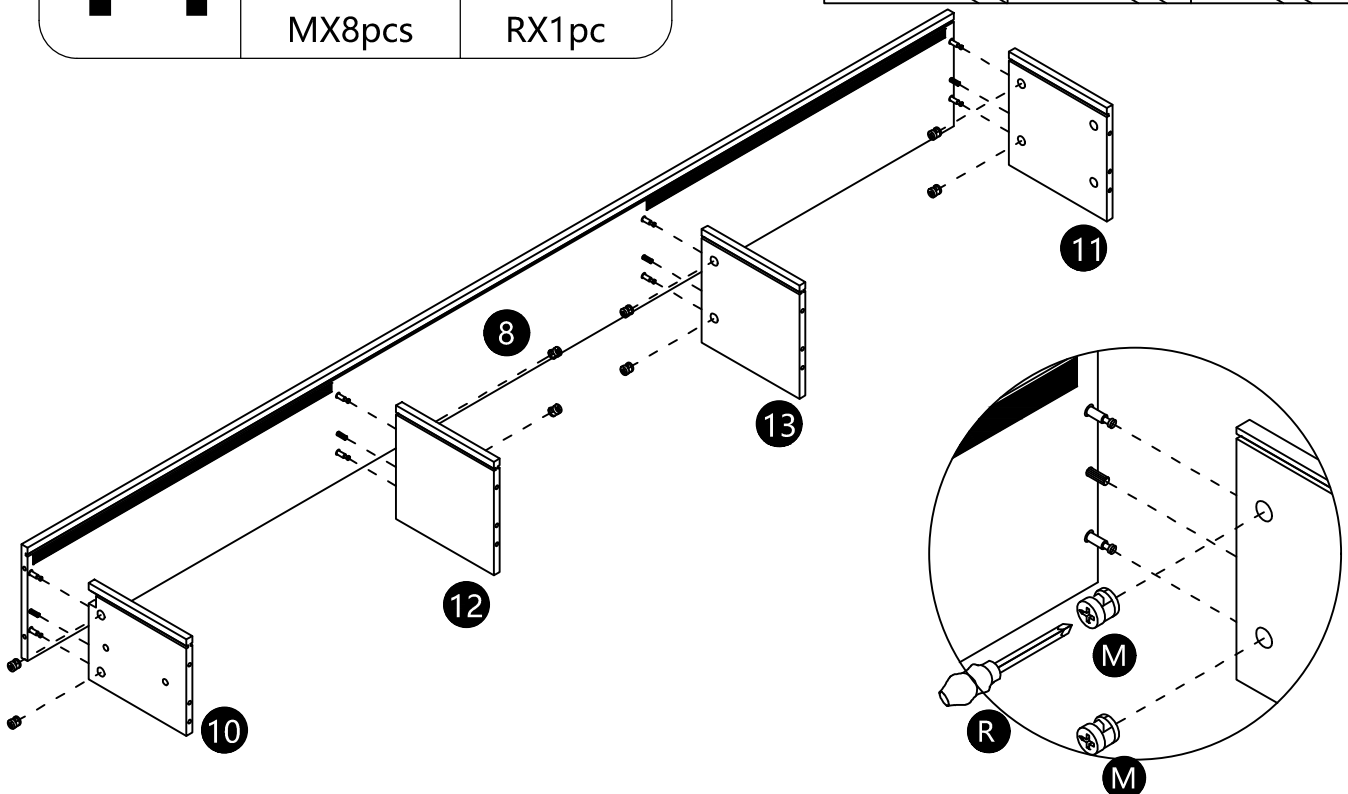
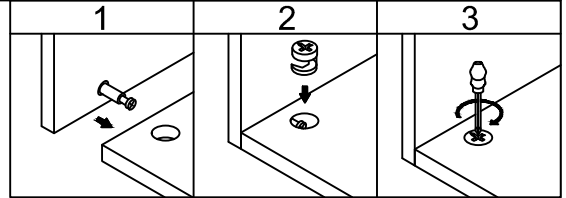

RX1pc

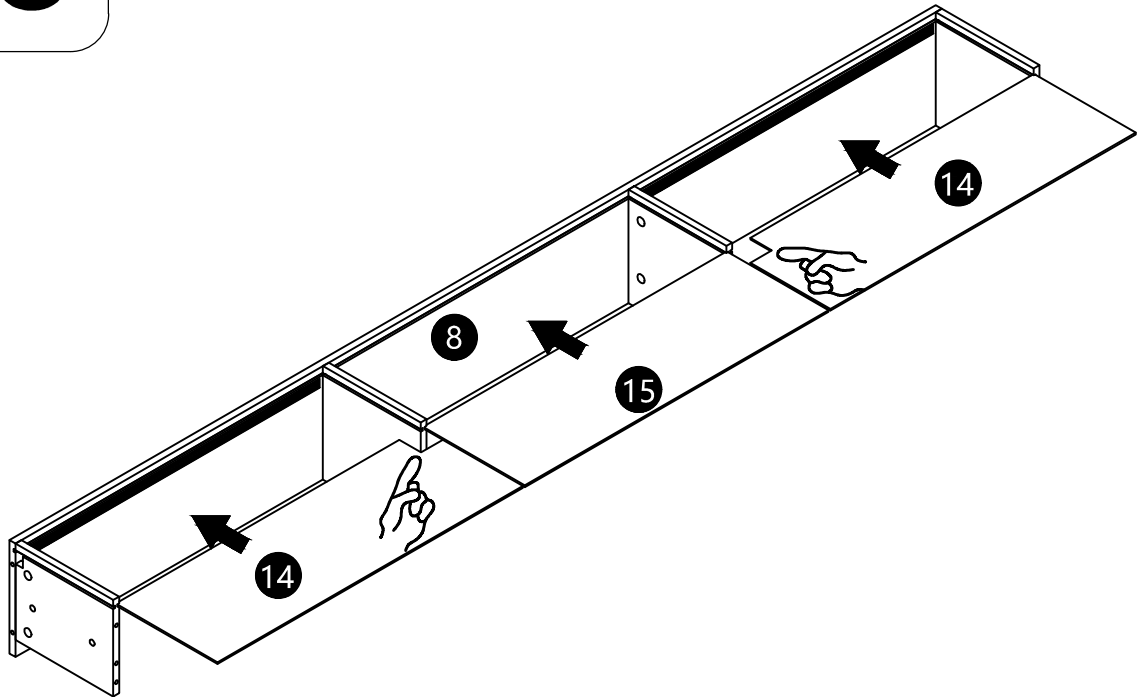

# 15

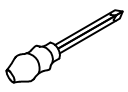

<h1>16</h1>			
	Ø6 NX4pcs	LX4pc	RX1pc

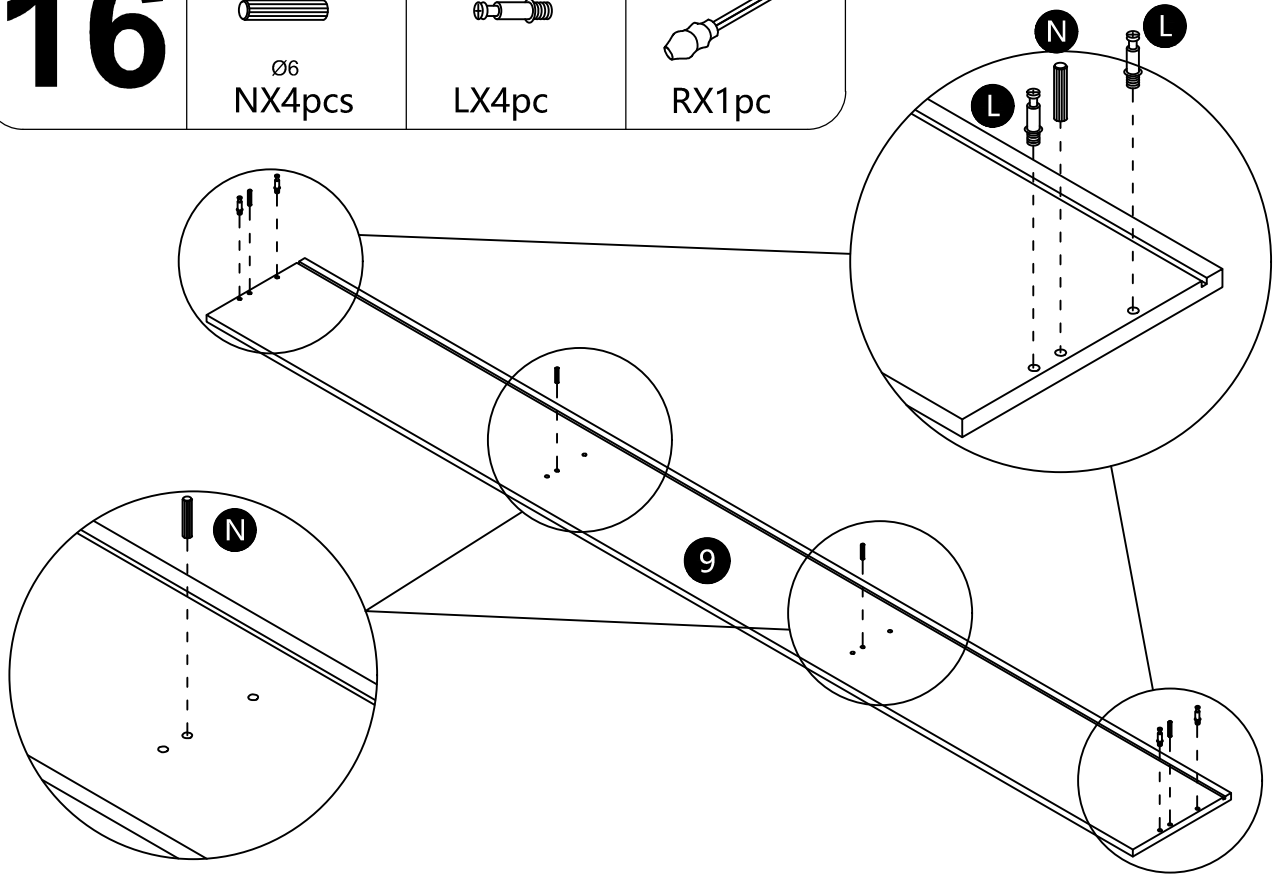

# 17

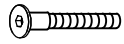

M5\*35  
KX8pcs



M5  
OX1pc



MX8pcs

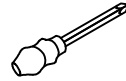

RX1pc

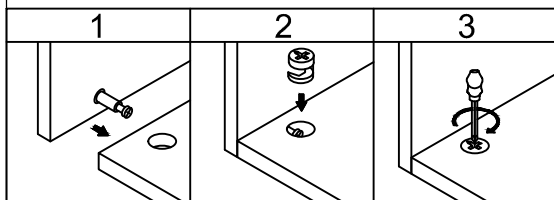
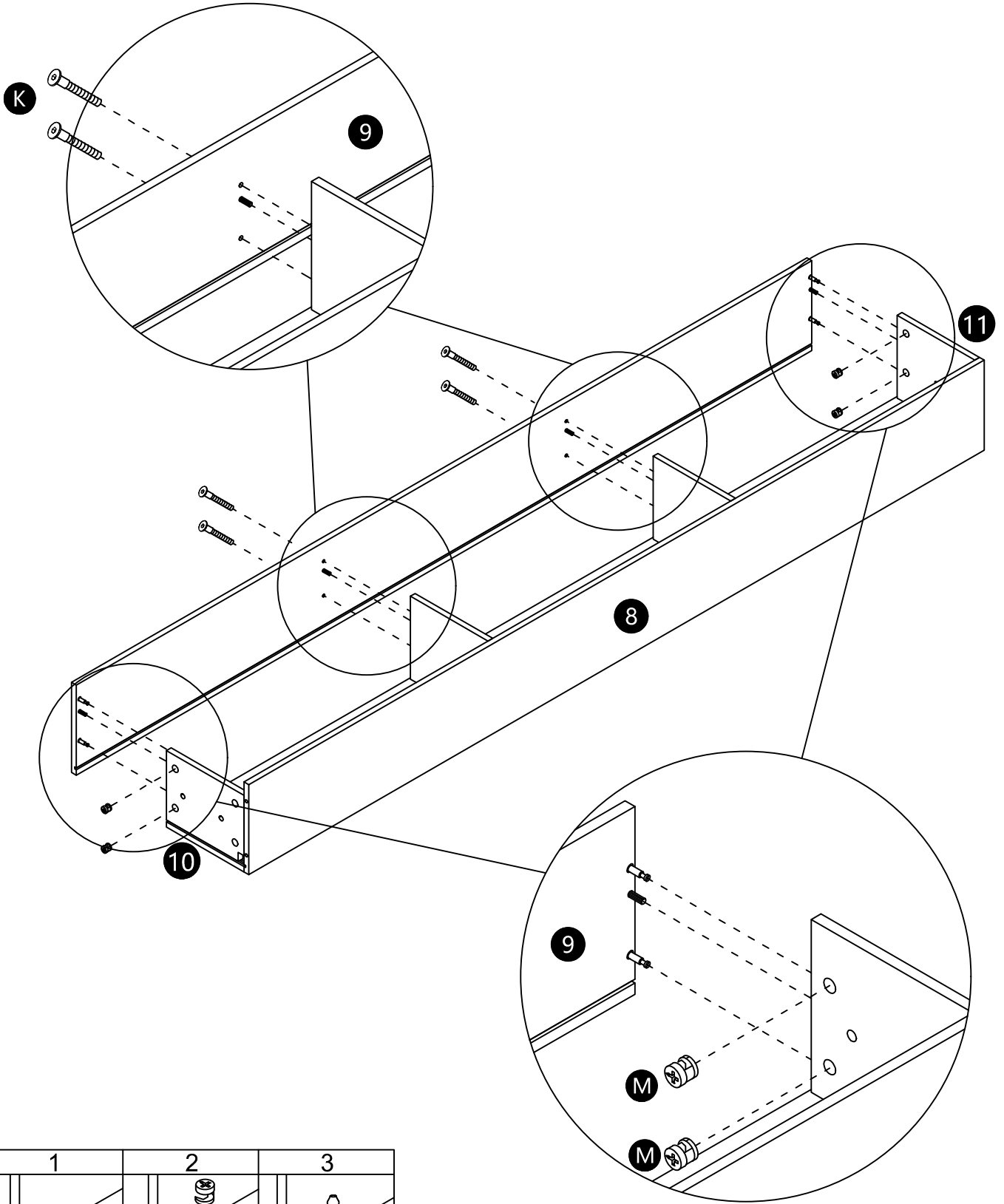

# 18

M6X10  
AX4pcs

M6  
PX1pc

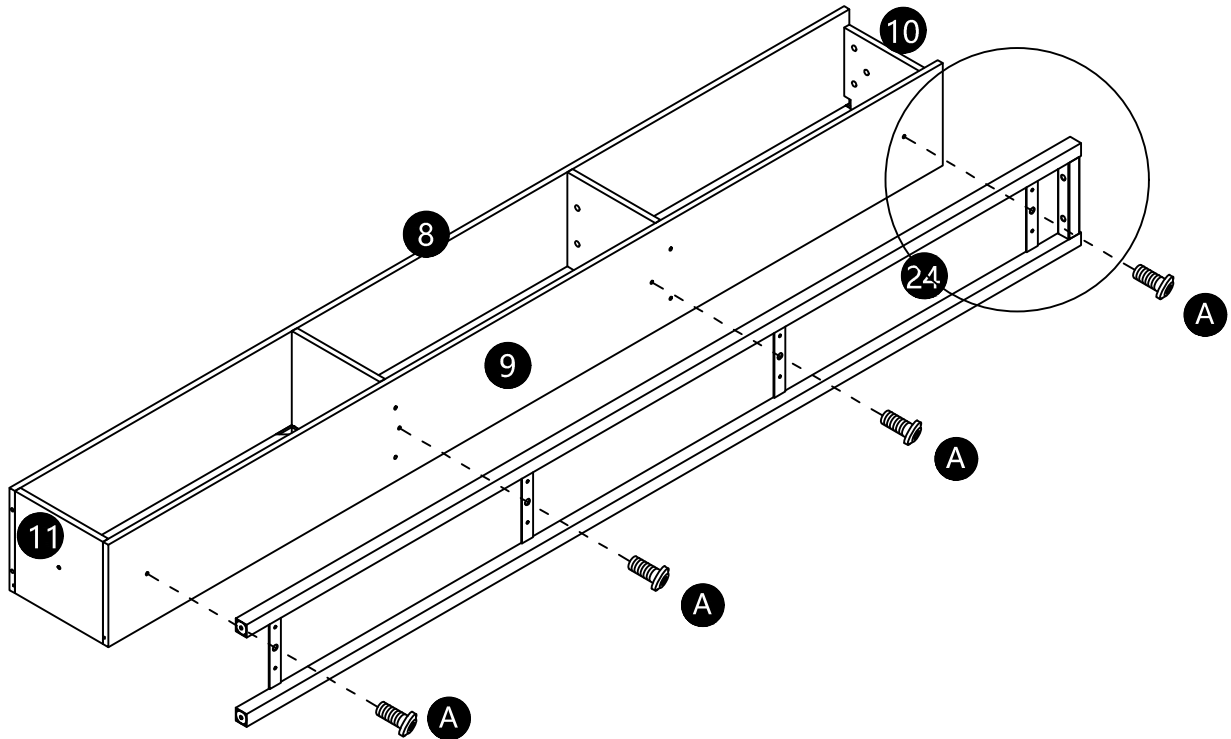

- \*Mind the position of the iron plate.
- \*Achten Sie auf die Position der Eisenplatte.
- \*Attention à la position de la plaque de fer.
- \*Tenga en cuenta la posición de la placa de hierro.
- \*Prestate attenzione alla posizione della piastra di ferro.

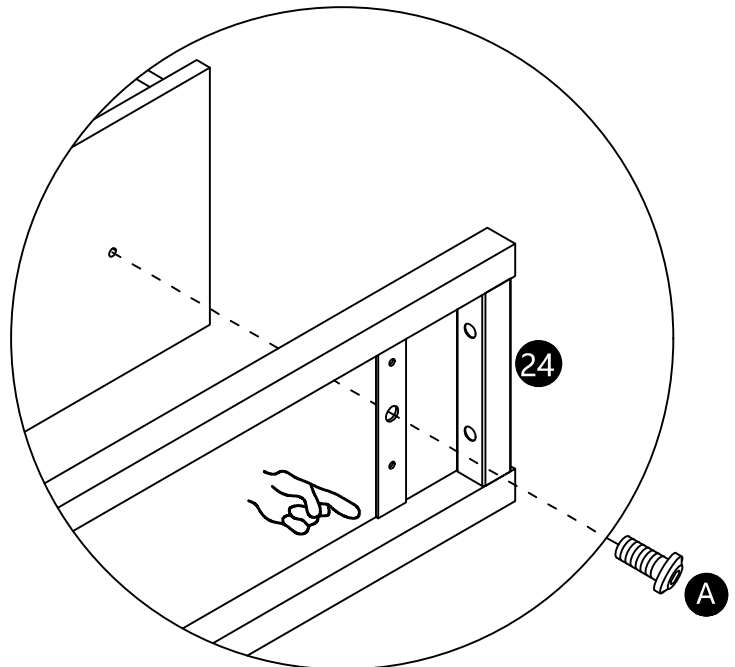

# 19



M6X33  
BX1pcs



M6X45  
CX2pcs



M6  
PX1pc

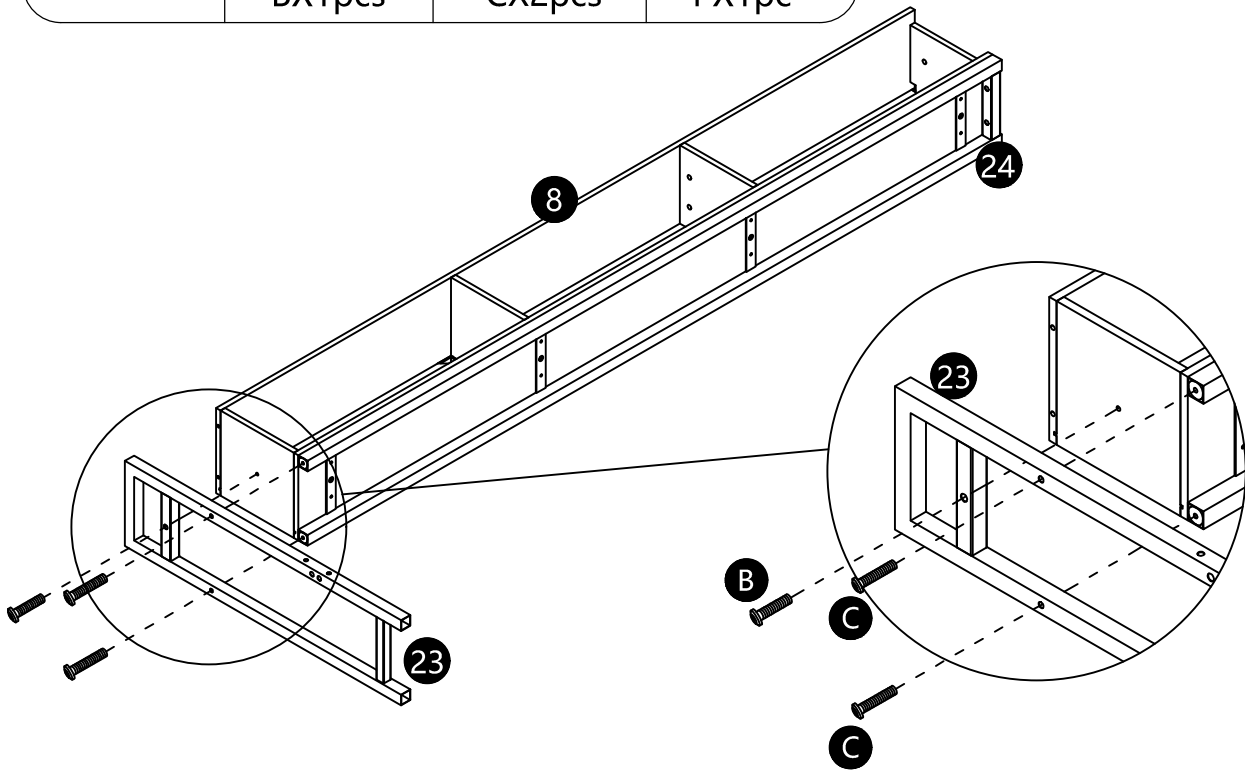

# 20



Ø6  
NX3pcs

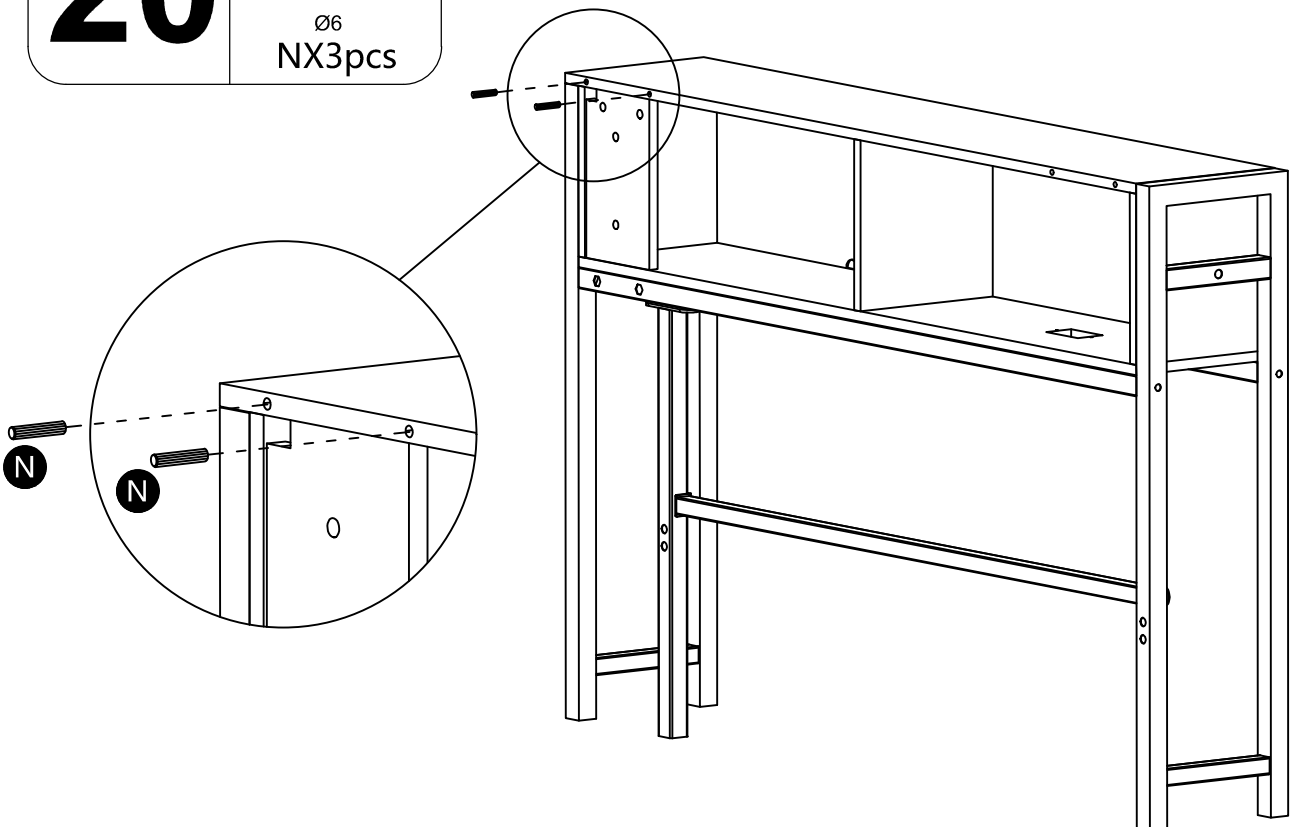

# 21



M8\*23  
FX2pcs



M8\*55  
HX2pcs

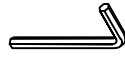

M8  
QX1pc

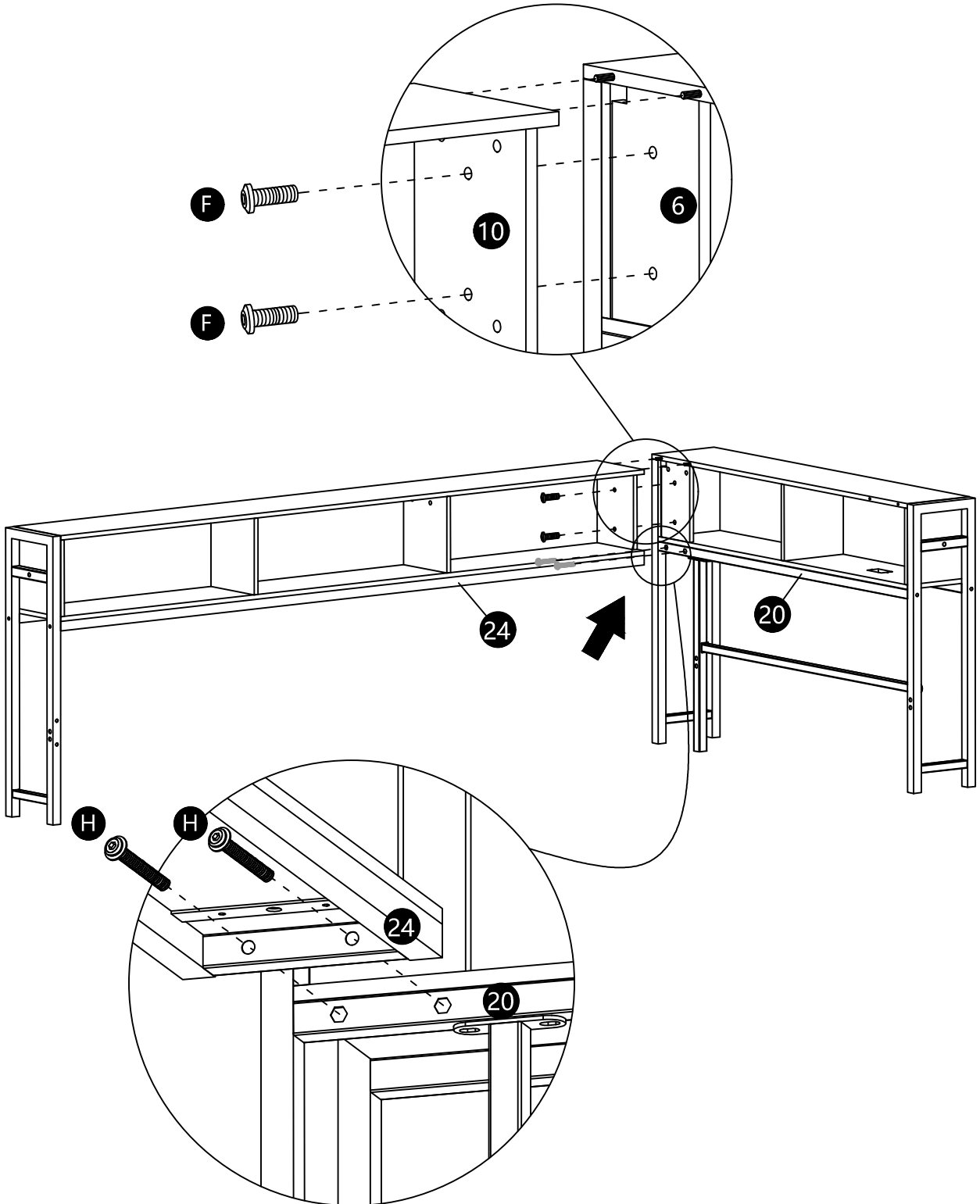

# 22

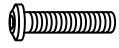

M8\*55  
HX4pcs



M8  
QX1pc

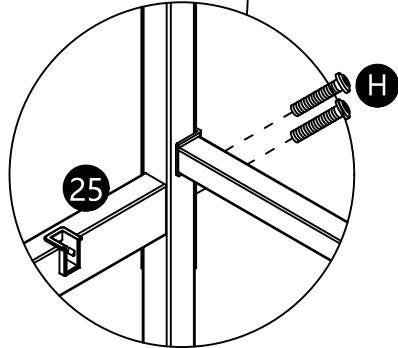
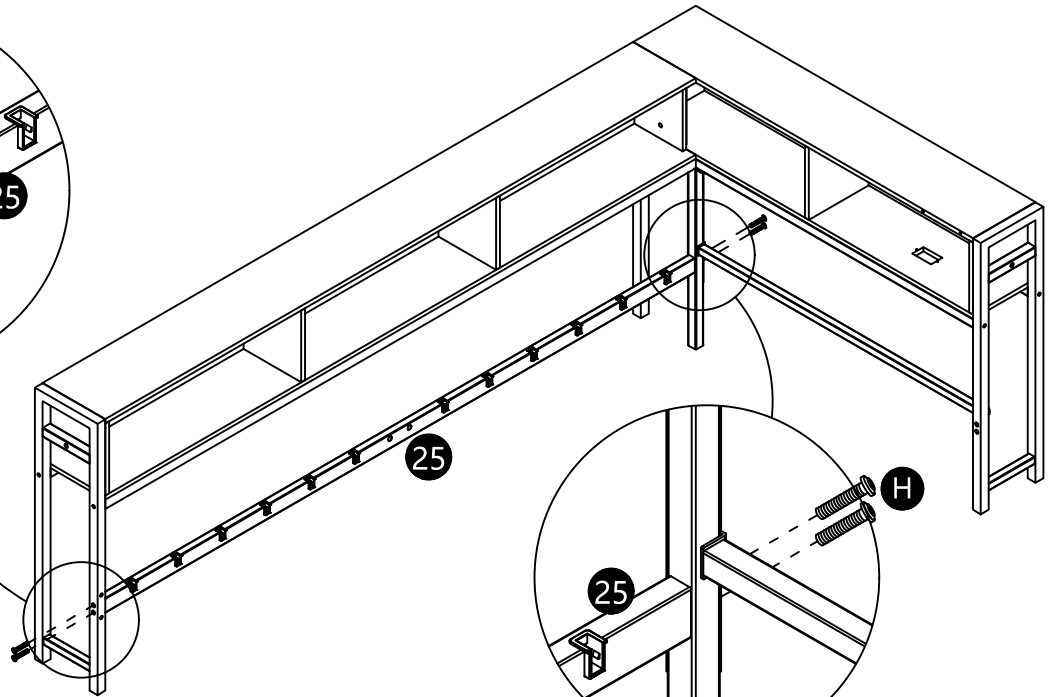
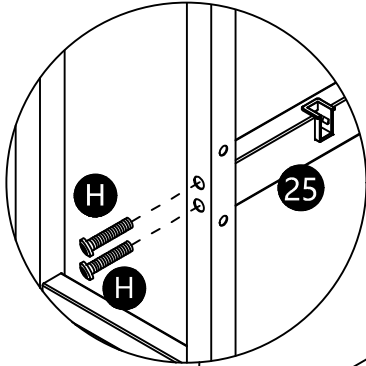

# 23



M8\*20  
EX2pcs



M8  
QX1pc

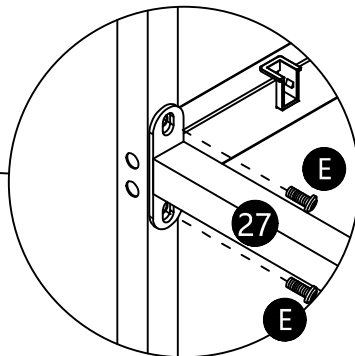
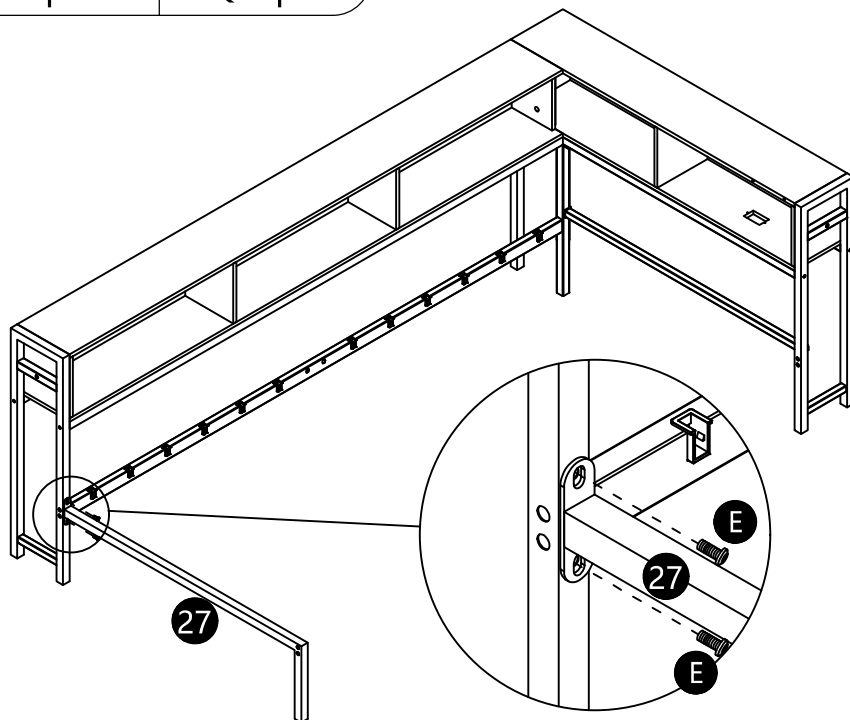

# 24



M8\*55  
HX4pcs

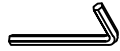

M8  
QX1pc

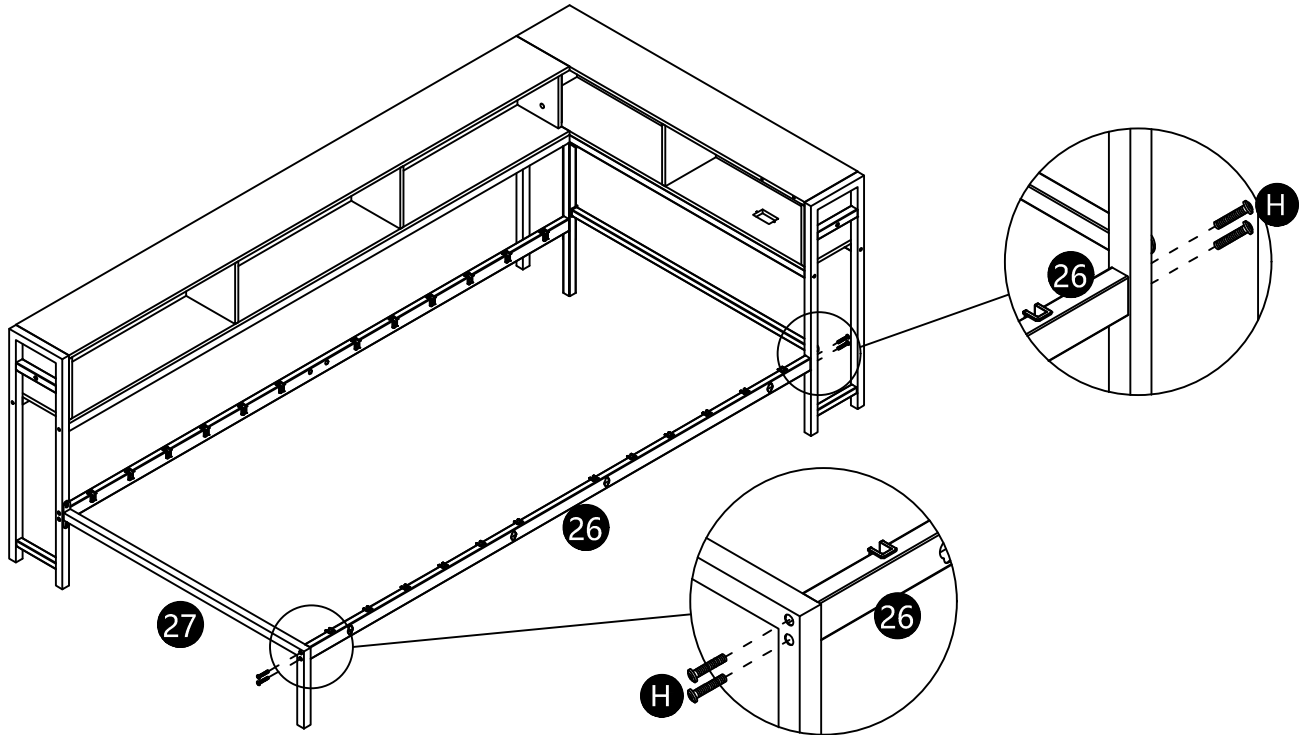

# 25



M3\*12  
JX2pcs

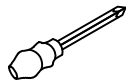

RX1pc

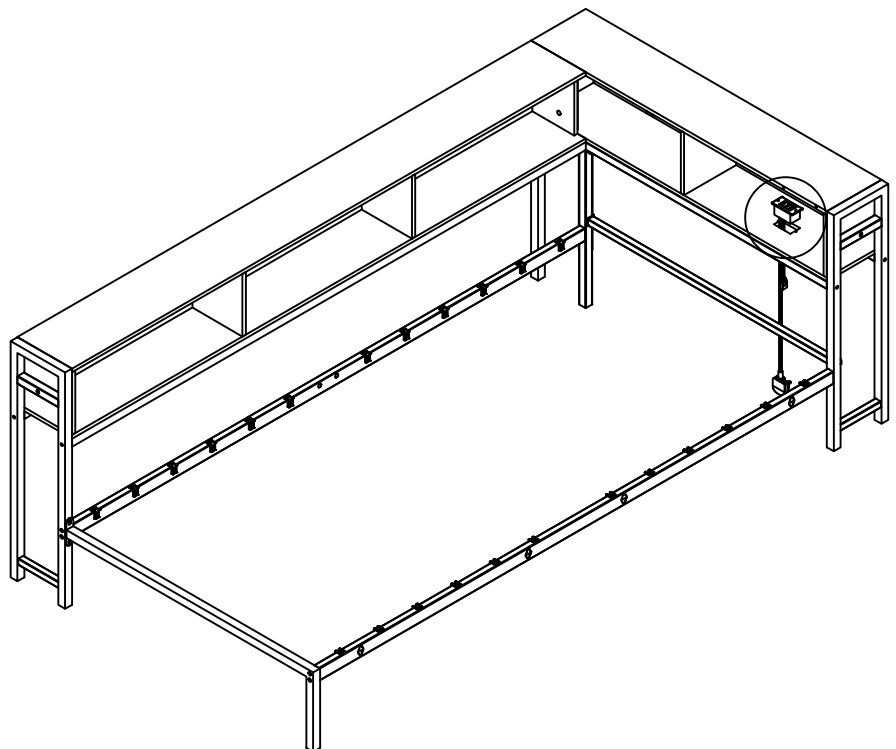
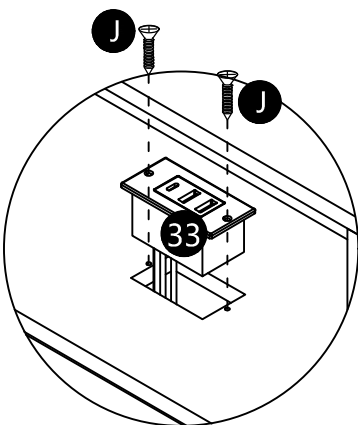

# 26

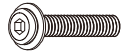

M8\*35  
GX4pcs

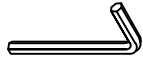

M8  
QX1pc

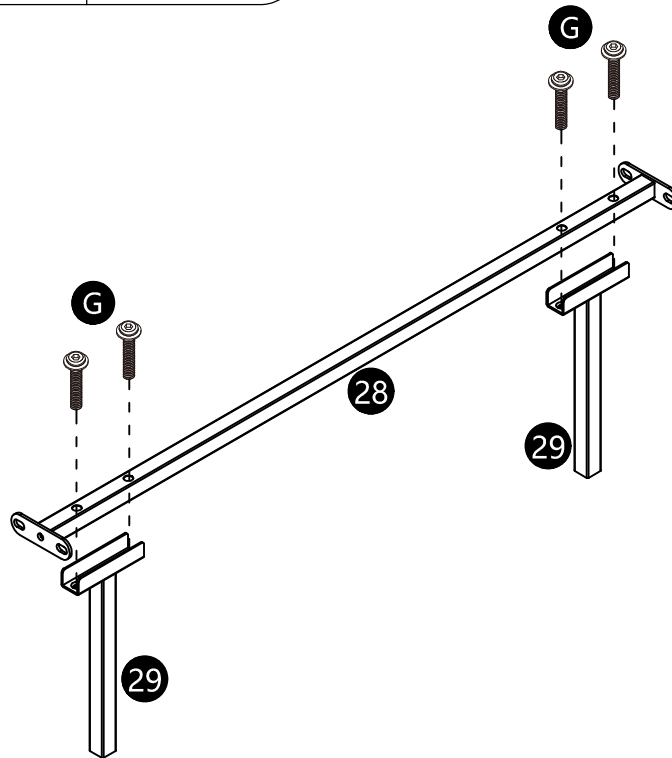

# 27



M8\*20  
EX4pcs

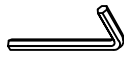

M8  
QX1pc

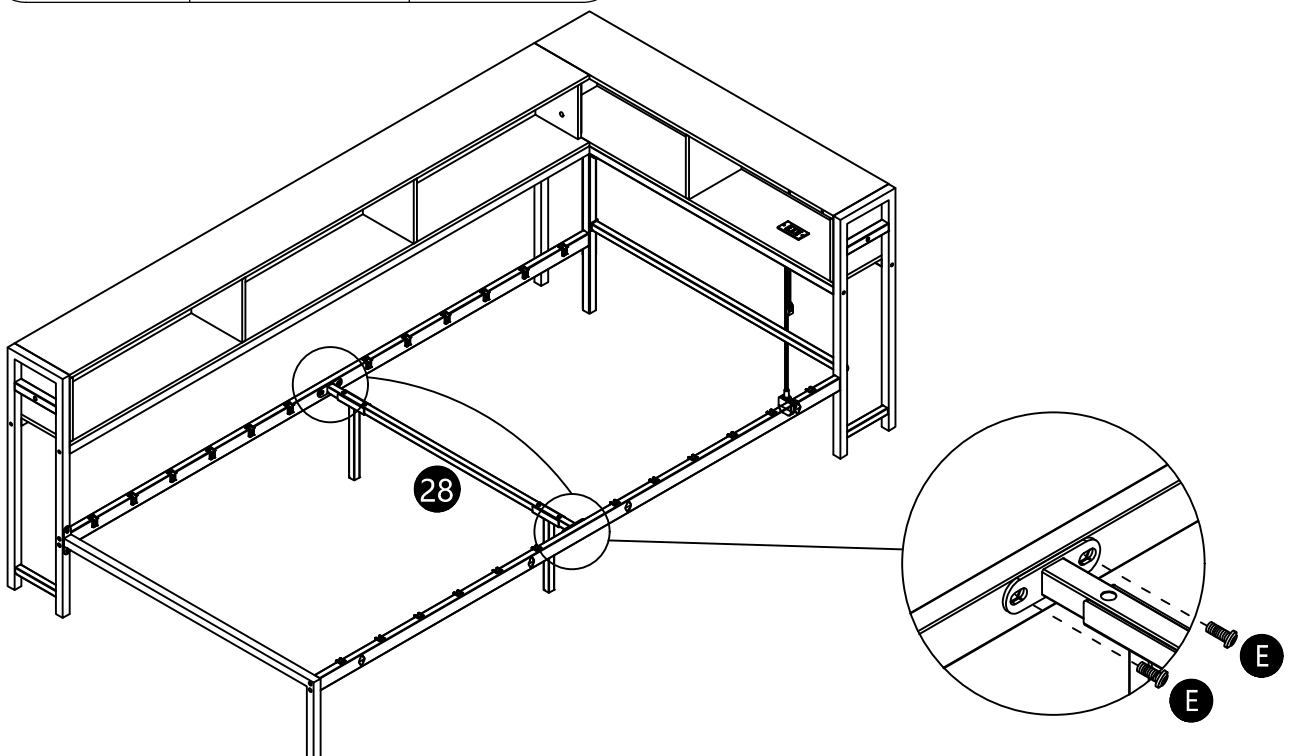

28

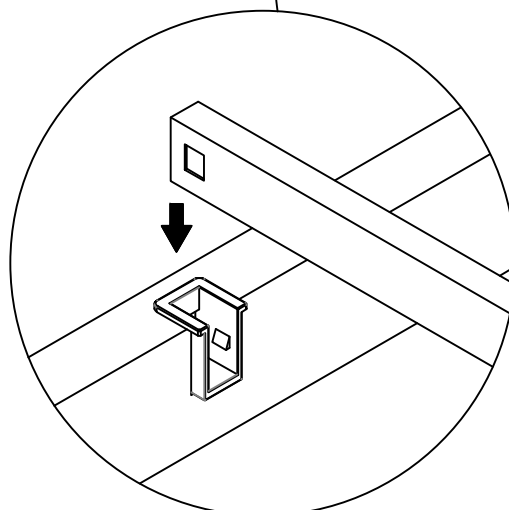
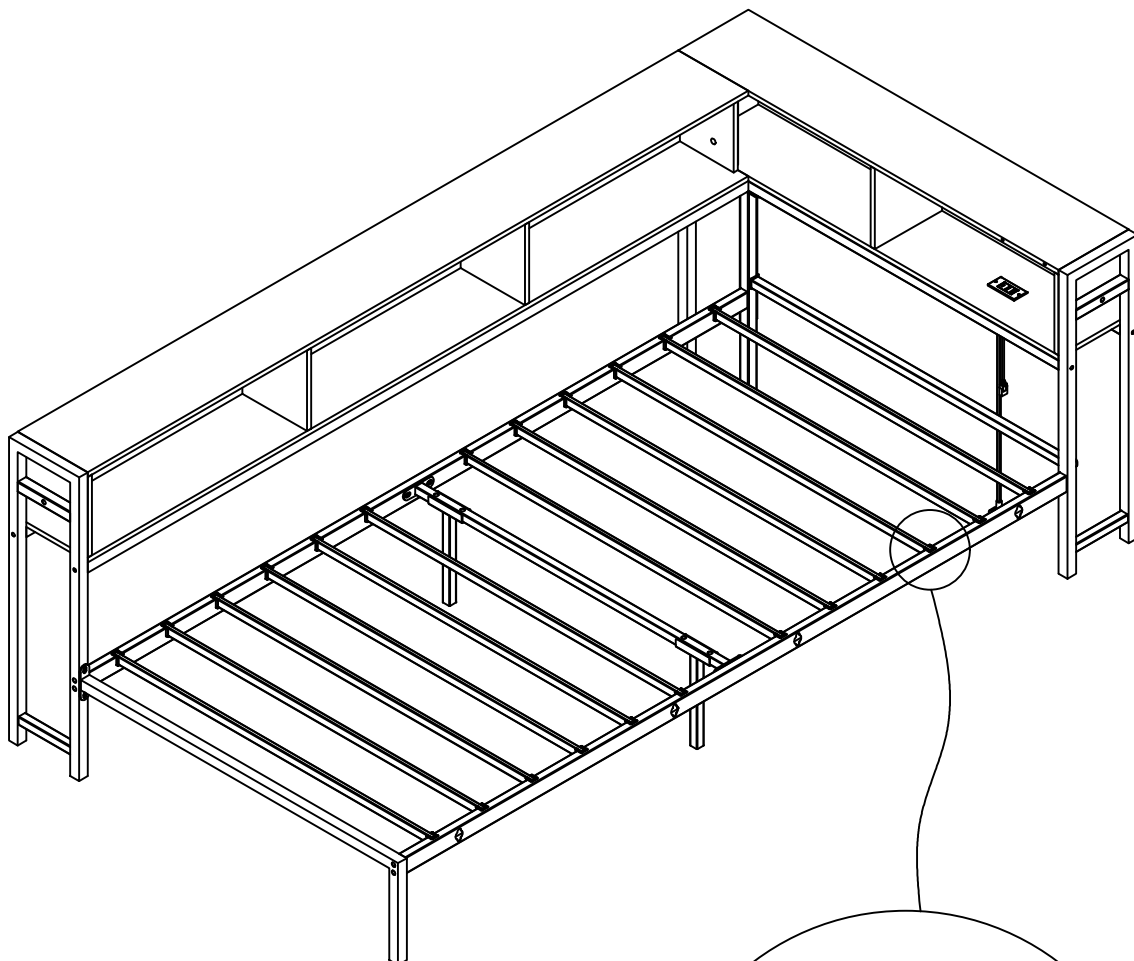

x12 **30**

# 29

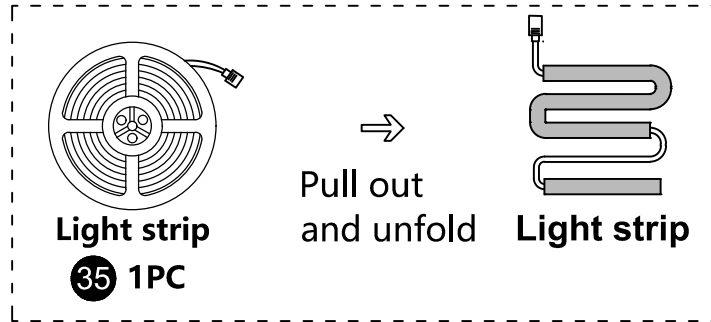

\*Stick the light strip onto the Velcro on the inner side of the bedside cabinet.

\*Kleben Sie den Lichtstreifen auf den Klettverschluss auf der Innenseite des Bettschranks.

\*Collez la bande de lumière sur le velcro sur le côté intérieur de l'armoire de chevet.

\*Ponga la tira de luz en el velcro en el lado interior del gabinete de cama.

\*Incollare la striscia di luce sul velcro sul lato interno del comodino.

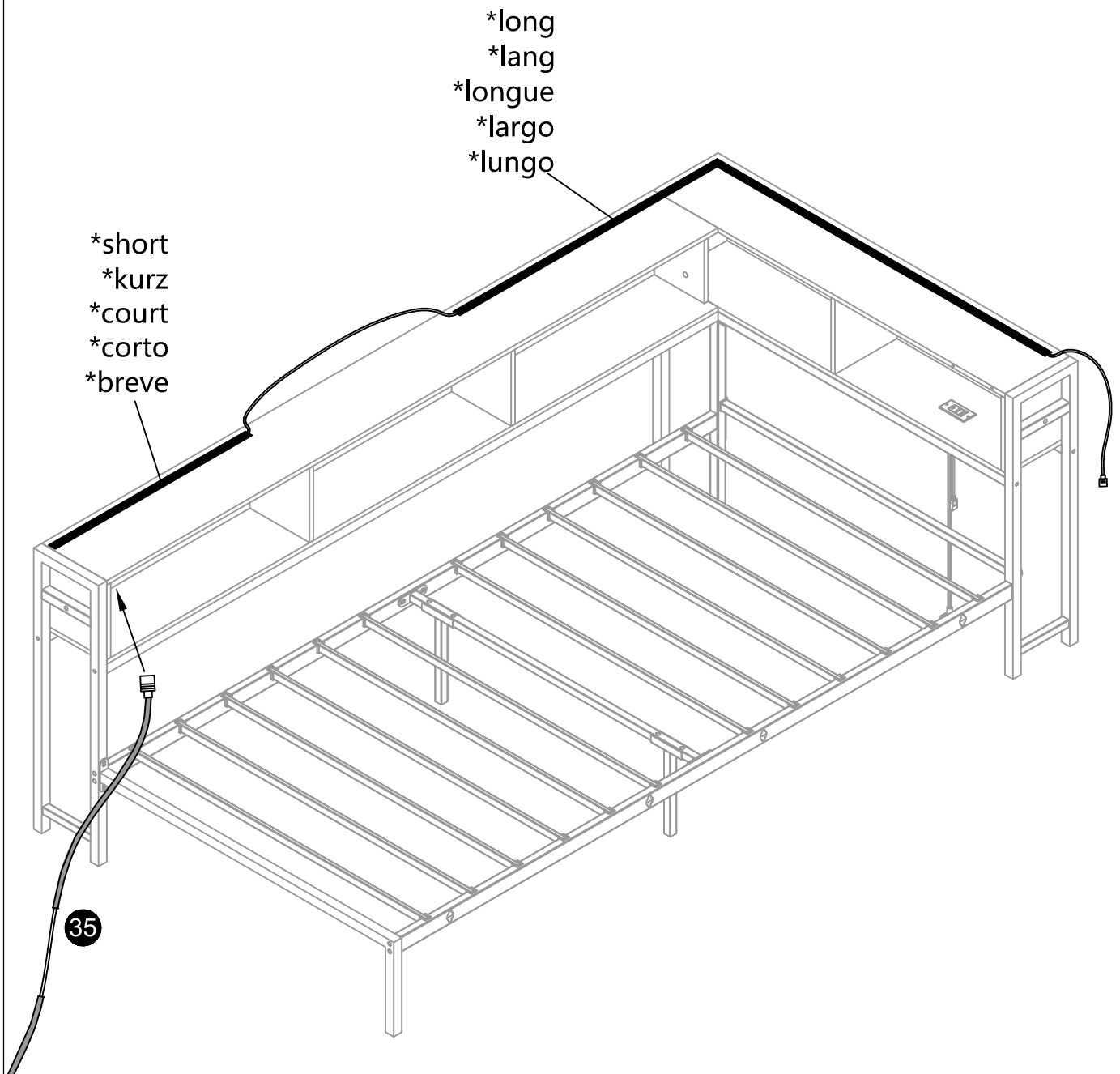

**30**



Magic tape  
SX2pcs

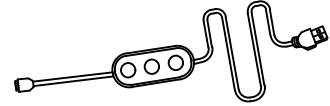

**36** Power cord  
1PC

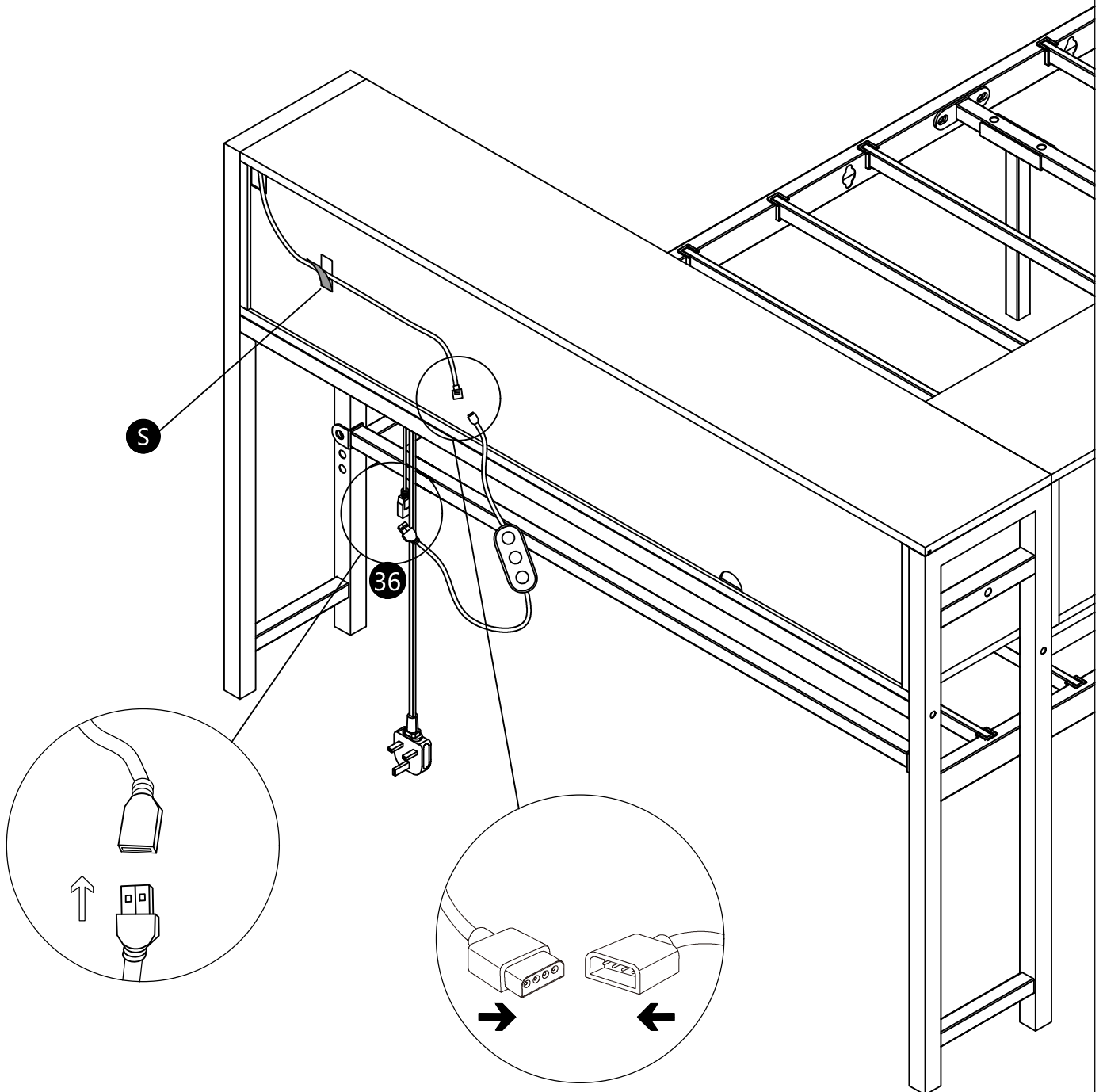

31

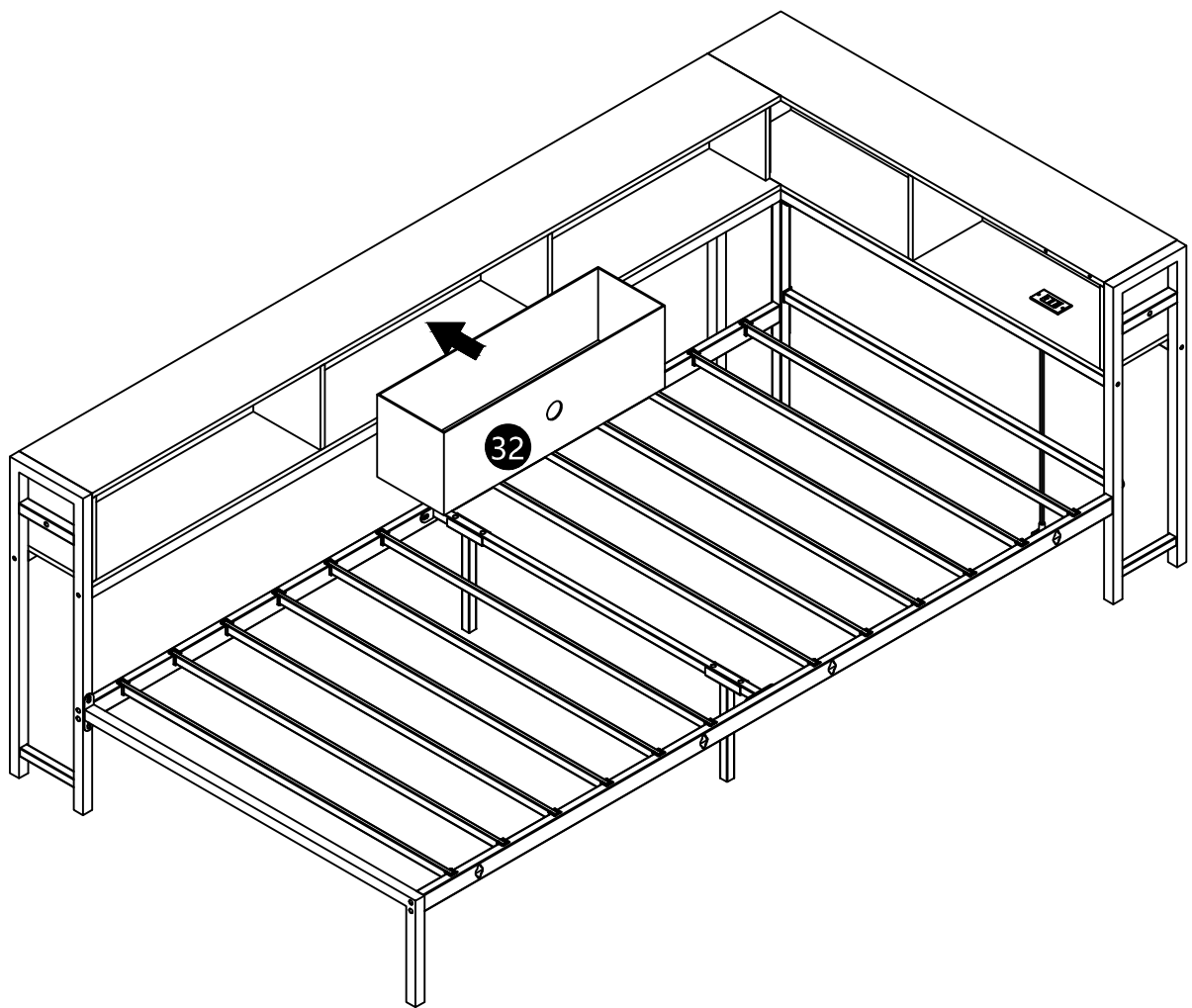

# 32



UX4pcs

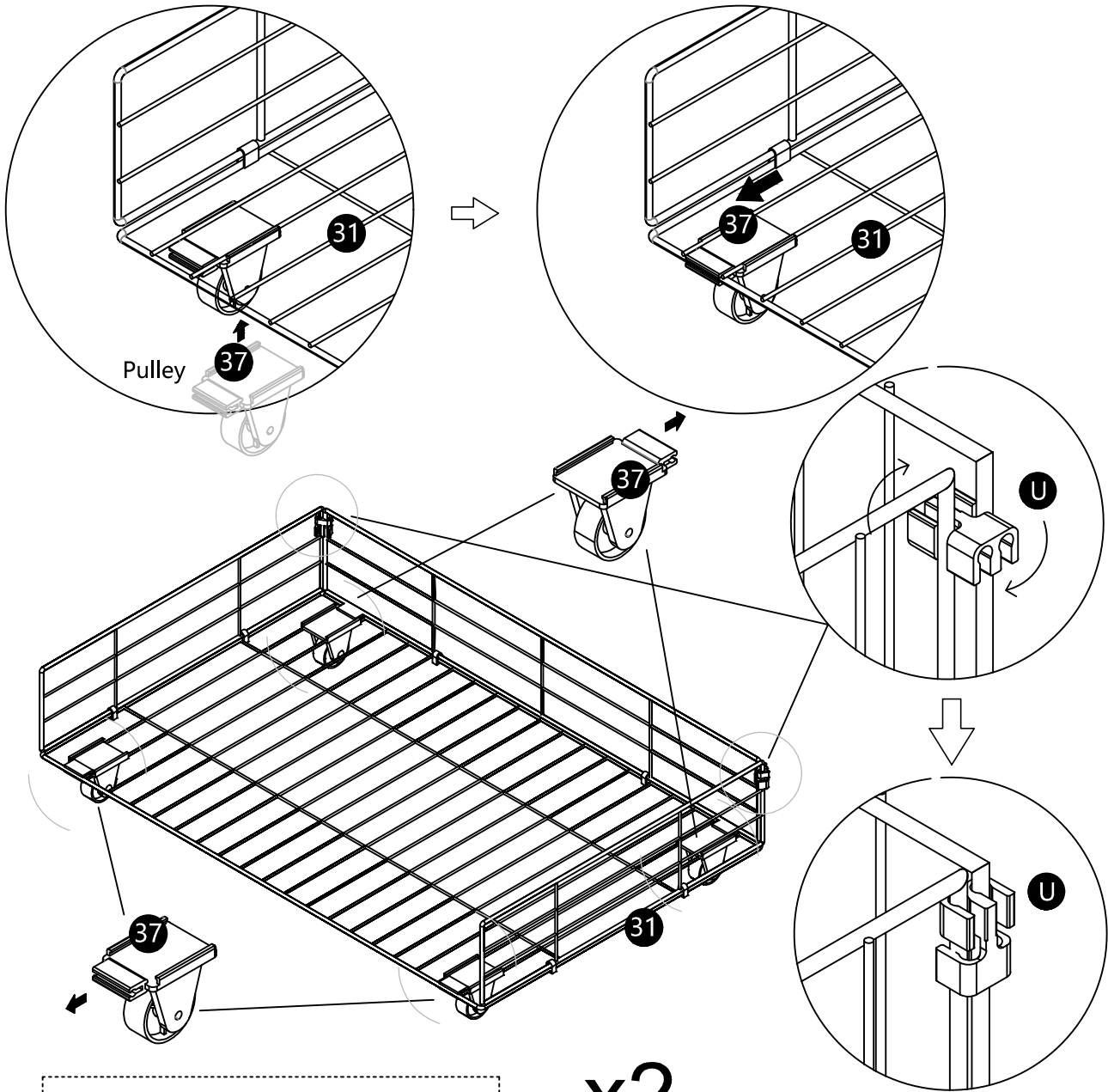

x2

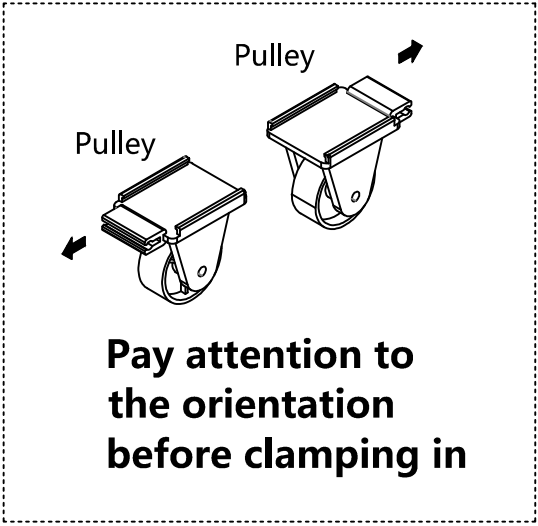

**Please note that this drawer base (31) has front and back sides! Please see the instructions clearly before assembling!!!**

# 33

  
M8\*10  
DX10pcs

  
M8  
QX1pc

  
TX6pcs

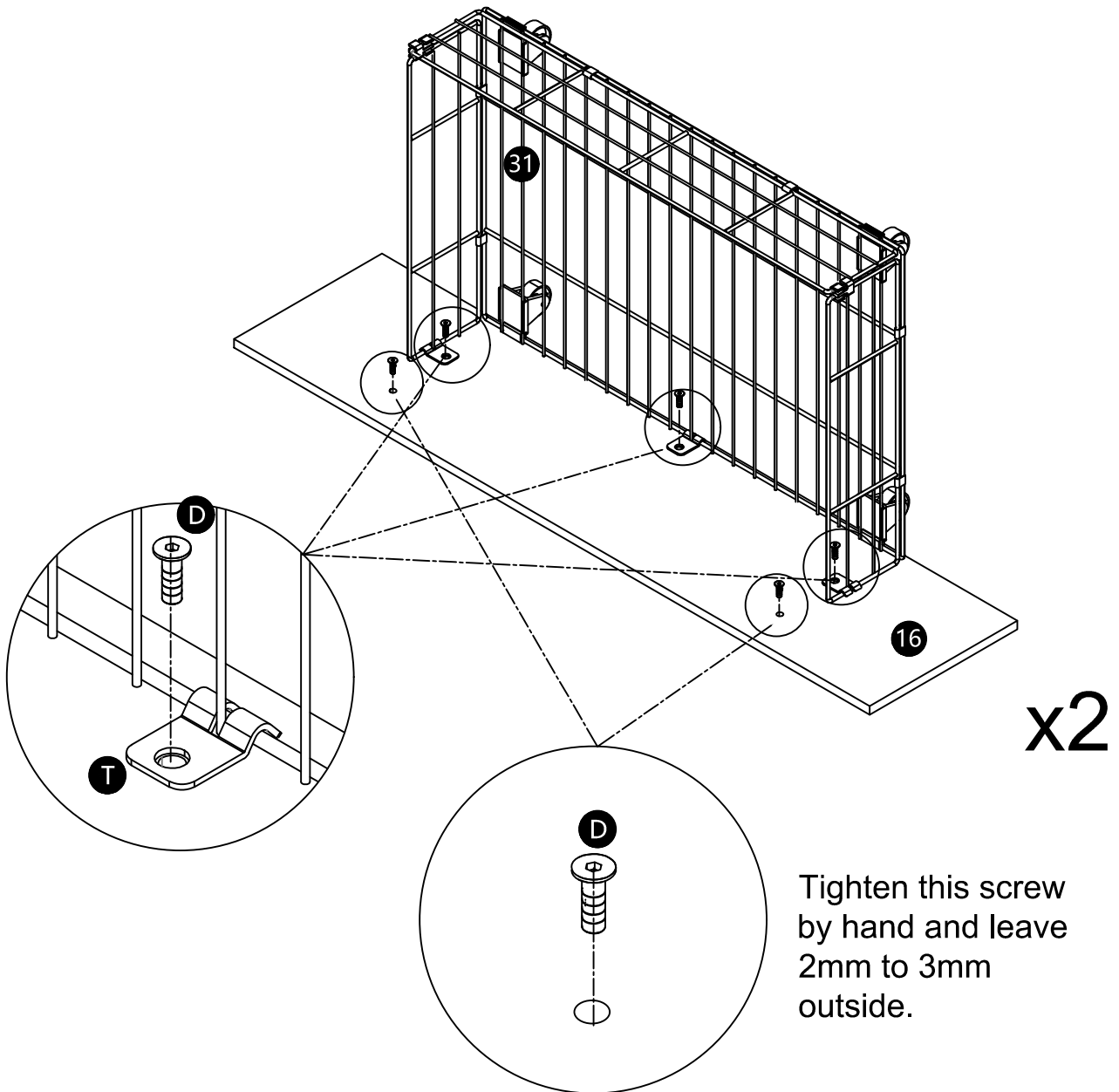

# 34

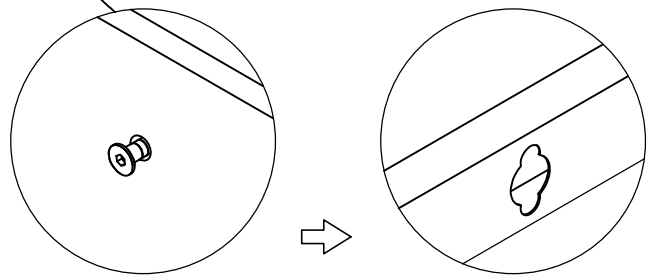
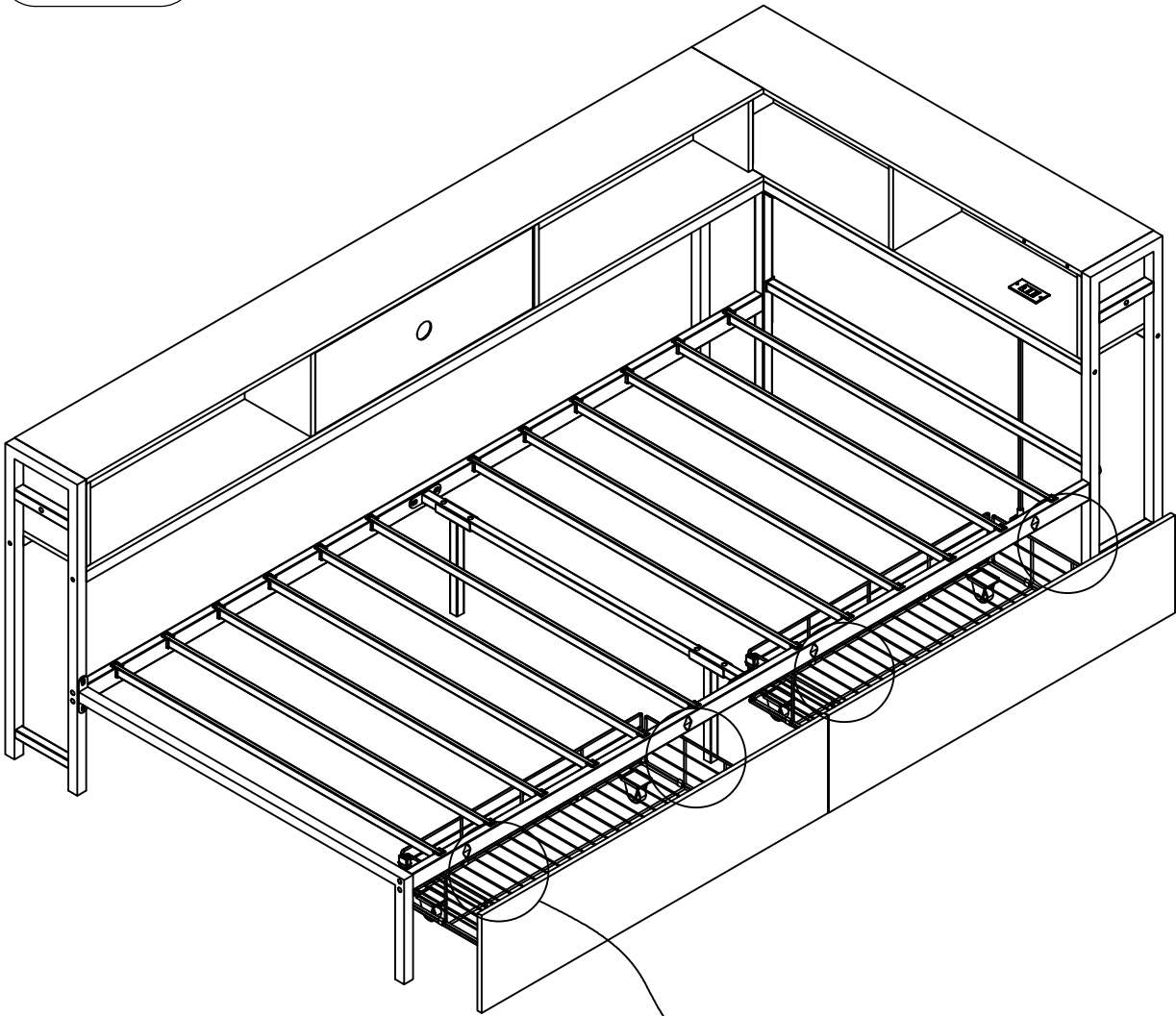

When pushing into the drawer, Lift the drawer gently,  
Align the screw with the gourd hole and push in  
When pulling out the drawer, Lift the drawer gently,  
Align the screw with the gourd hole, and then pull it out