

3 TIERS PRINTER RACK INSTRUCTION

Assembly Steps:

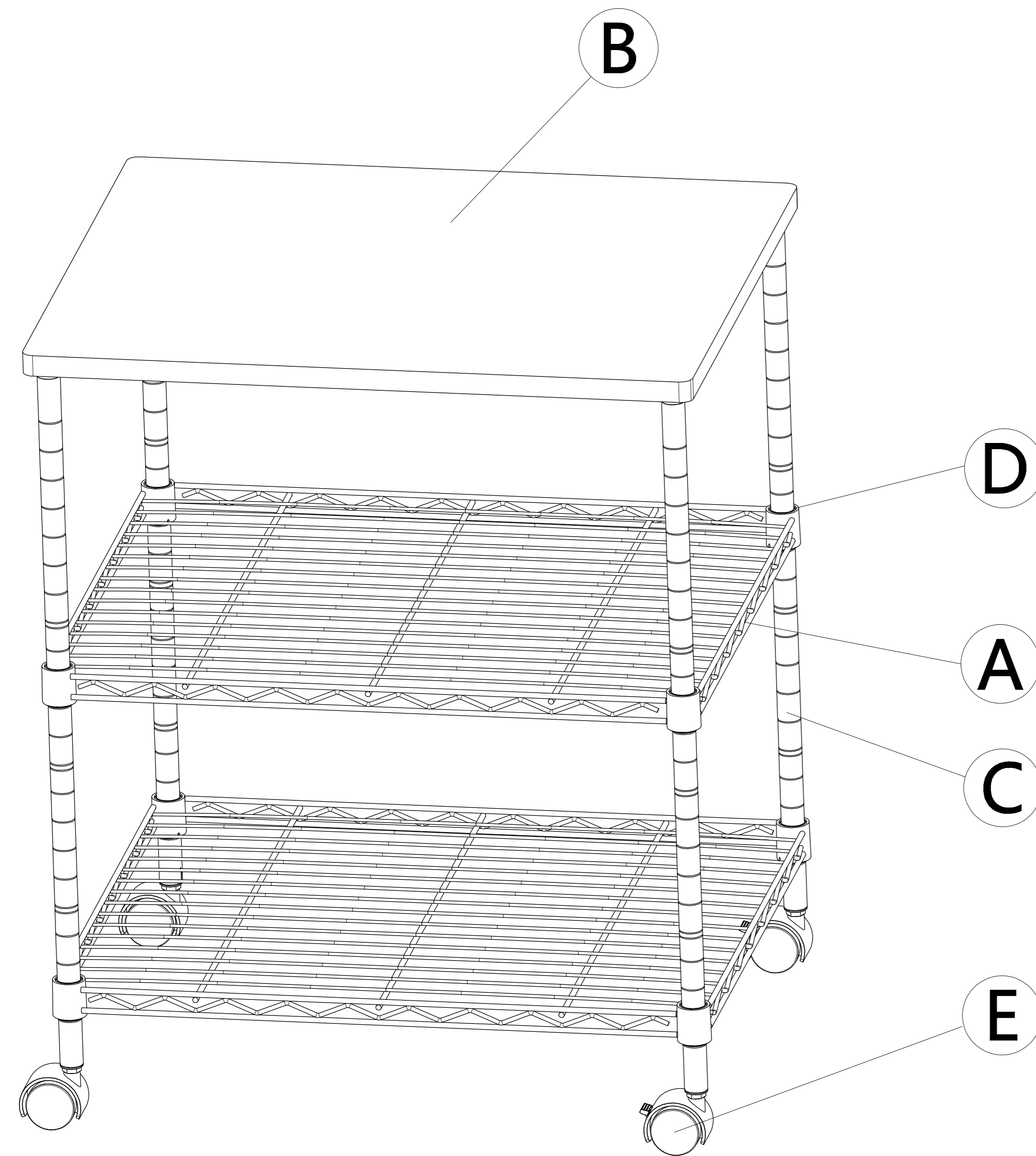

1 Screw Nylon Casters (E) into the bottom of four Poles (C) by wrench. Snap one pair of Plastic Clips (D) on the same groove of each pole as the photo. The arrow of all plastic clips should be pointed up, and the grooves of pole should be covered by convex part of plastic clips.

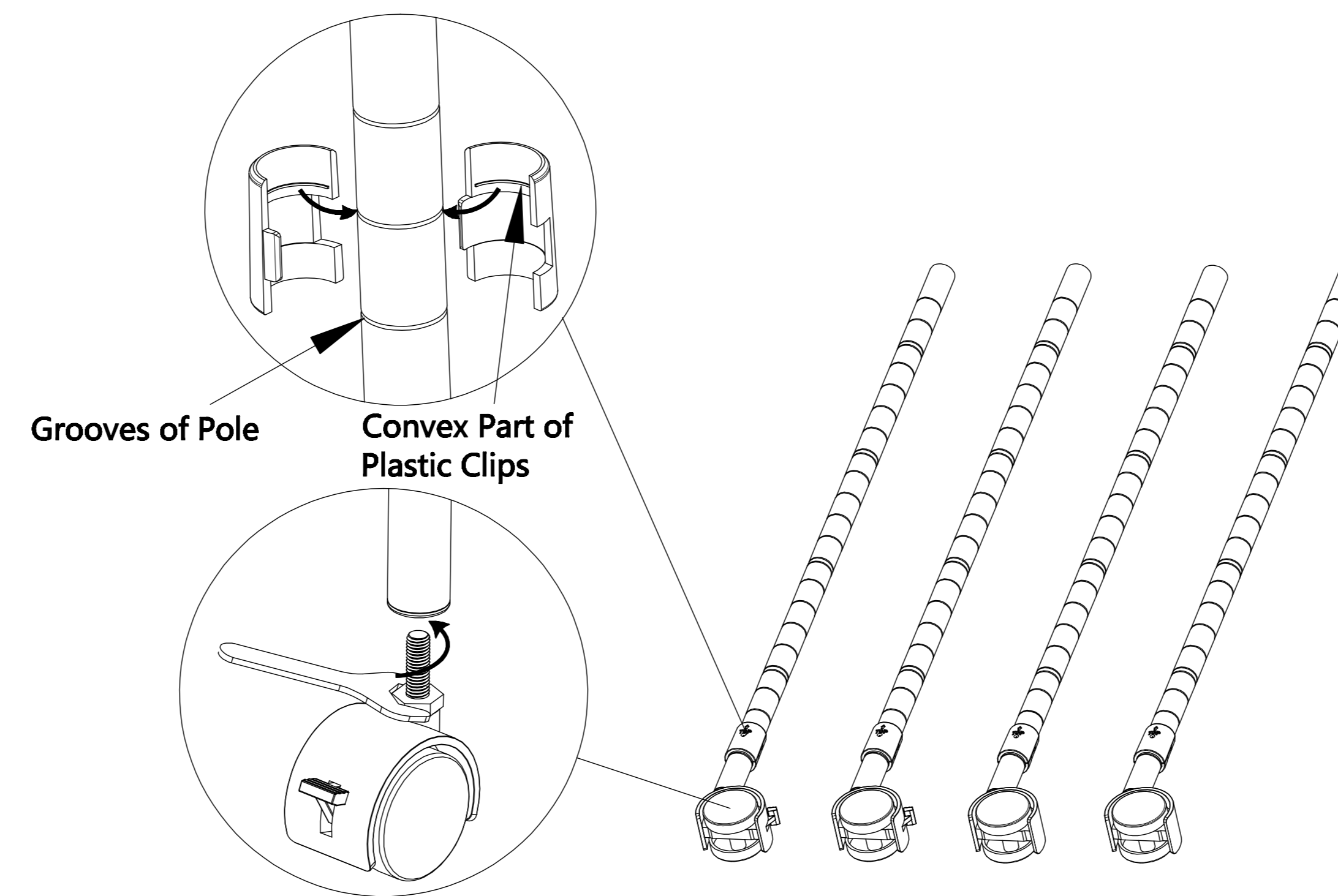

2 Please make sure that you have the Wire Shelf (A) the correct way up. Keep the collar of the Wire Shelf (A) downward. Then slide the Wire Shelf (A) into the plastic clips from the top of each pole.

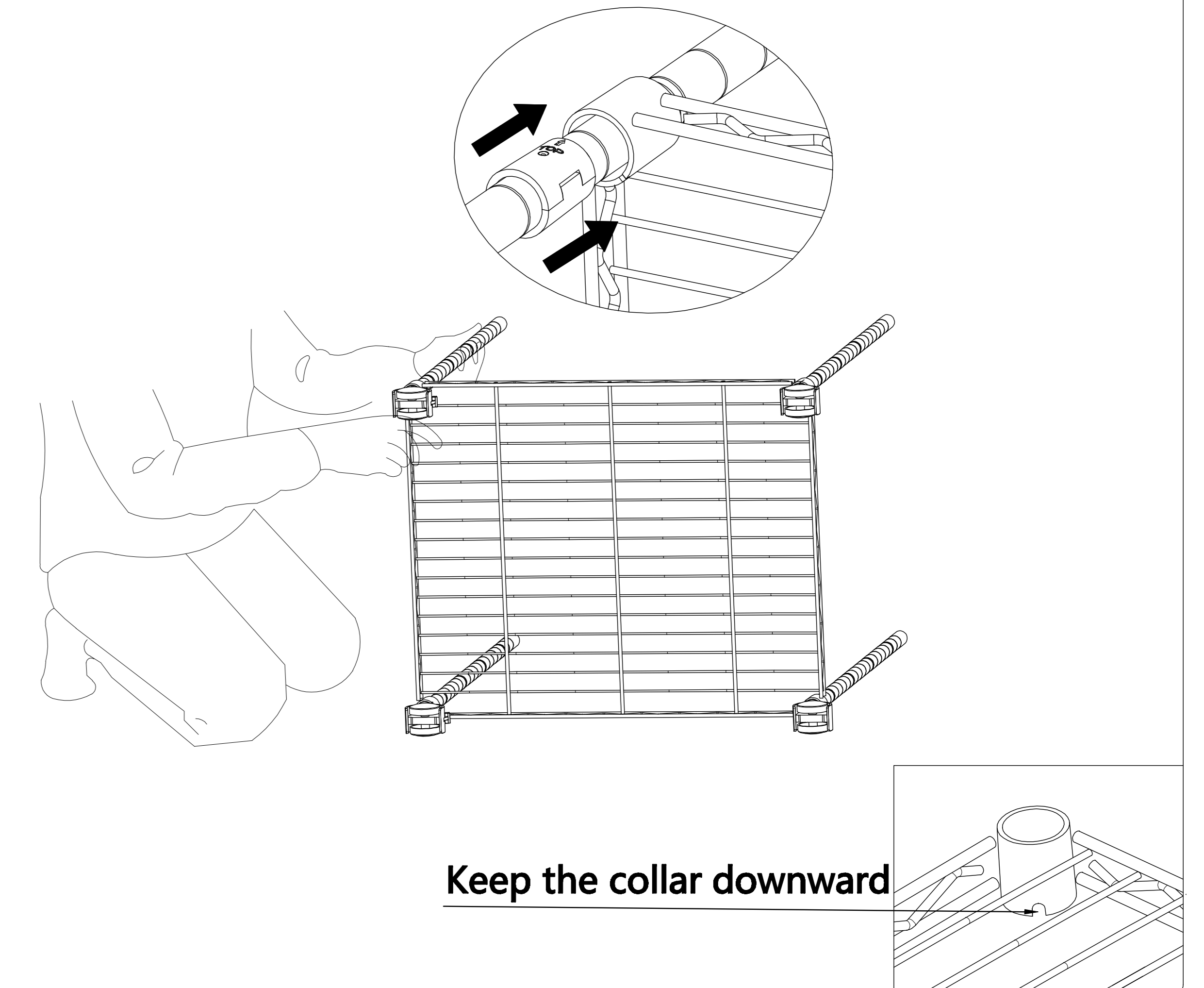

3 Set the shelf upright. Refer to Step ①, ② to snap the plastic clips (D) on the same grooves of each pole at your desired position for the second wire shelf (A). And then assemble the second wire shelf (A).

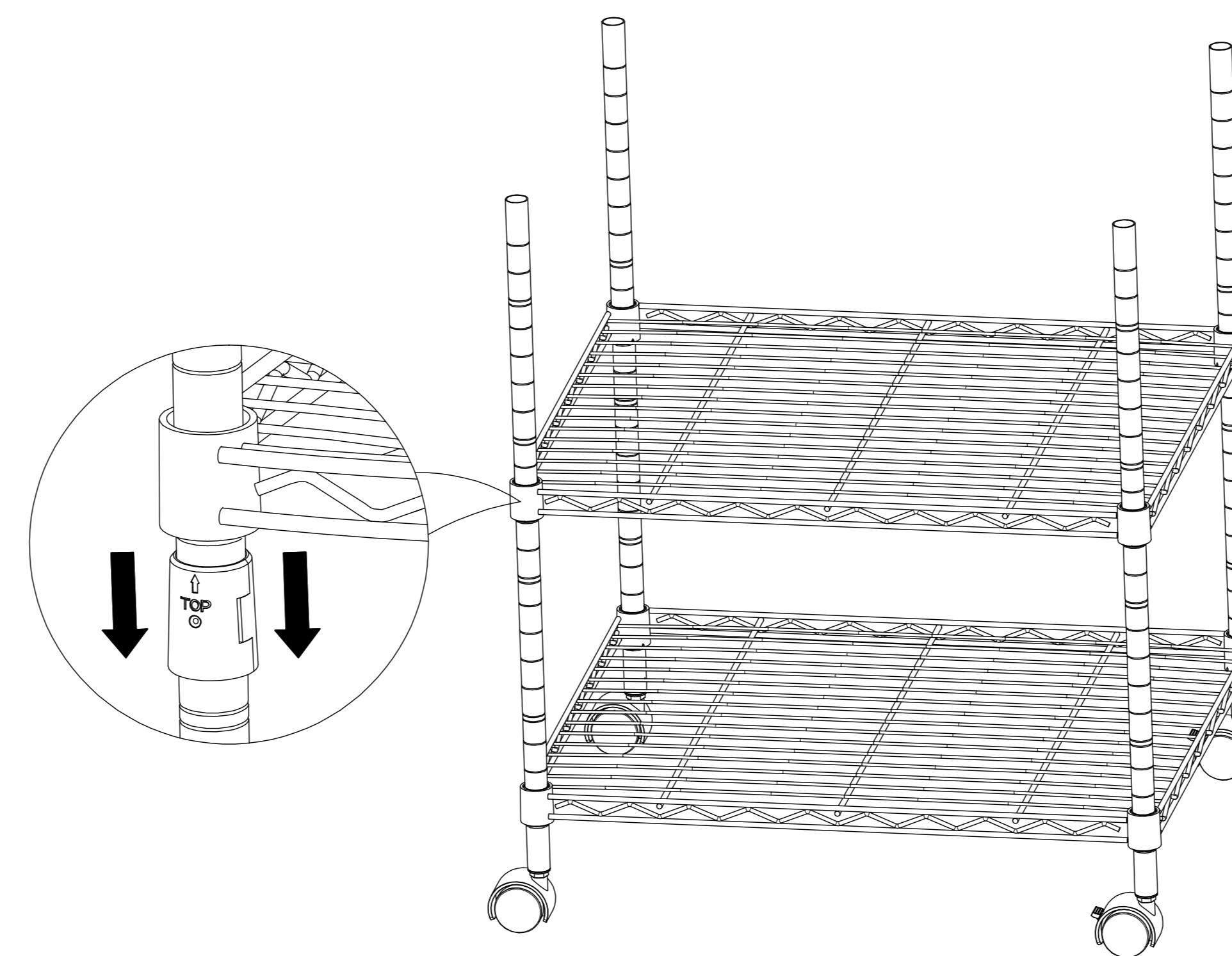

4 Insert the plastic parts under the Wooden Board (B) into the top of the four poles to make it snug on the poles. Push firmly down the corners of the two wire shelves (A) by rubber mallet to make the wire shelf (A) secure onto the plastic clips. Now the three tiers printer rack is completely assembled.
NOTE: Put fabric between rubber mallet and shelf to prevent damage.

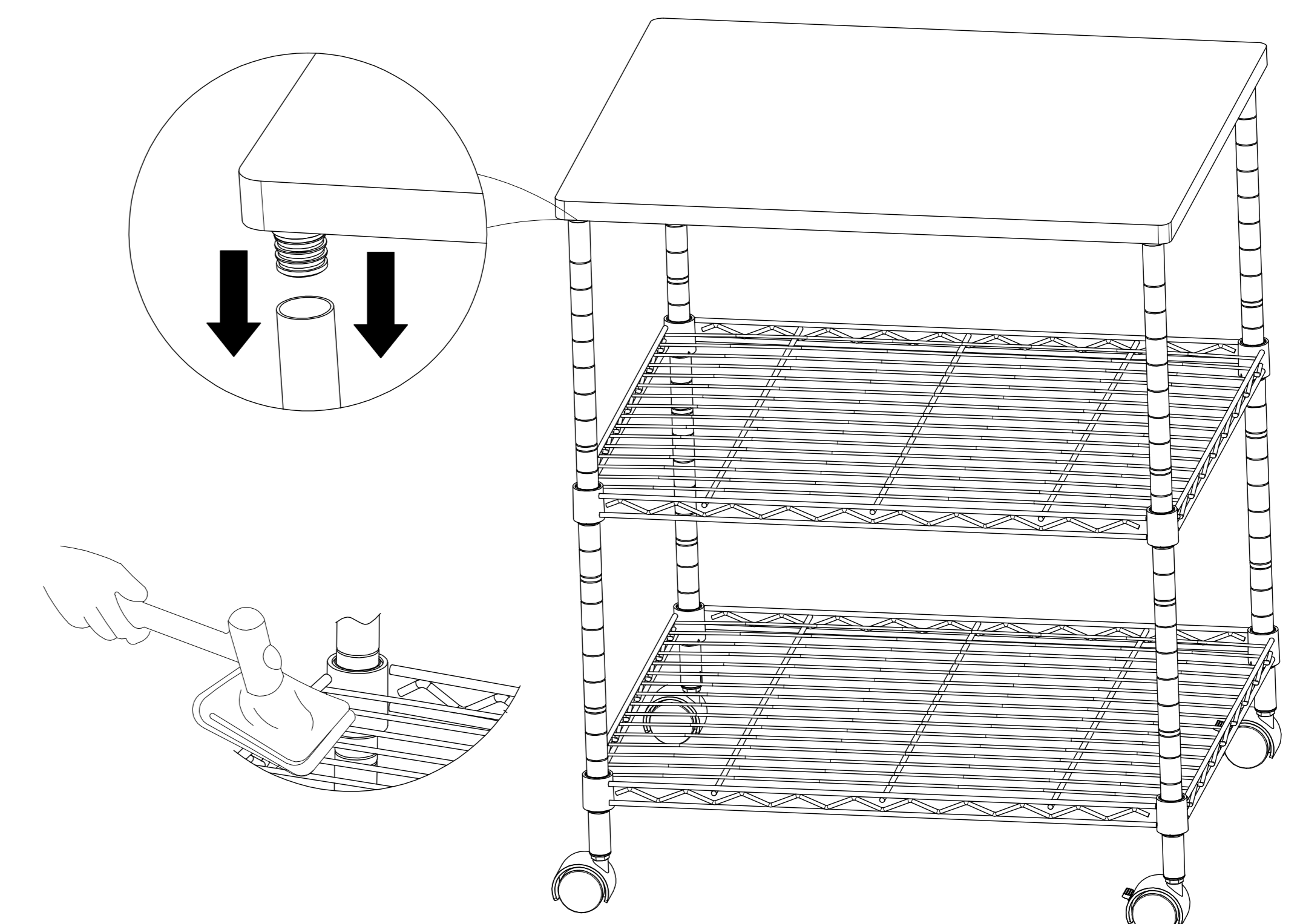

No.	A	B	C	D	E
Name	Wire Shelf	Wooden Board	Pole	Plastic Clip	Nylon Caster
Parts					
Quantity	2PCS	1PC	4PCS	16PCS	4PCS