

ASSEMBLY INSTRUCTIONS

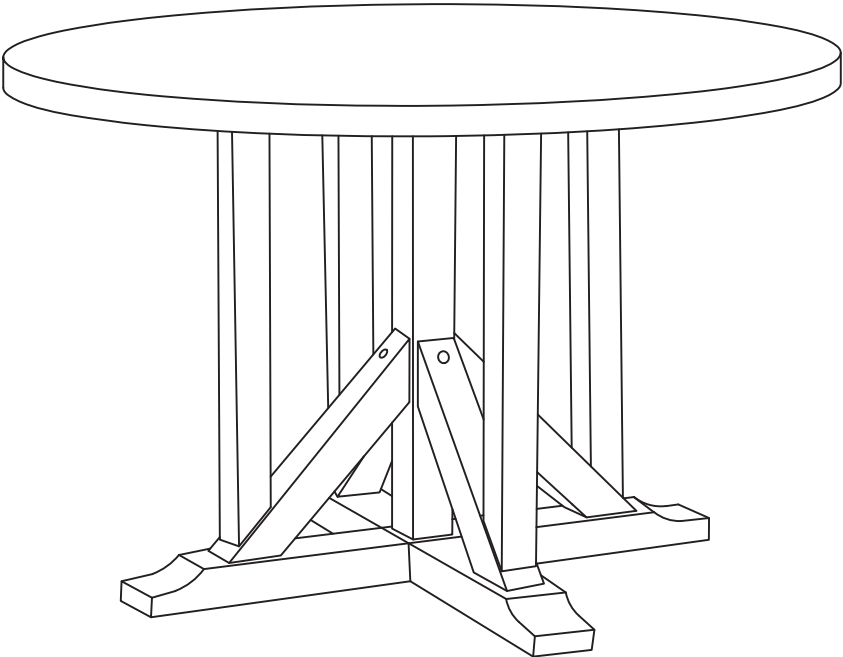

TOOLS REQUIRED



Allen Wrench
(Included)



**2 - People
Recommended**

ASSEMBLY RATING



EASY —————> DIFFICULT

The Assembly Rating is a 5-point system showing the level of effort needed to assemble a specific product.



CHECK BEFORE STARTING

Are you missing anything?

Double-check all parts, hardware and accessories listed are all accounted for.

Check out our Quick Tips!

We recommend reviewing the pre-assembly handouts. Even experts need a refresher now and then!

Should we send any replacements?

Are there any irregularities or flaws in the parts? We can send replacements!

Prep Time!

Please review the assembly instructions and all diagrams prior to assembling.

PRE ASSEMBLY INTRODUCTION

We understand building ready-to-assemble furniture can be a challenging experience for some. To help avoid confusion, we have provided some helpful tips that may speed up the process.

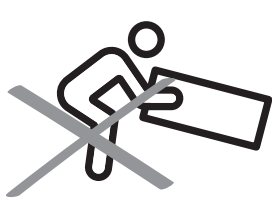

Teamwork

ALWAYS have at least two people to help with transporting and assembling the product to avoid potential injury and/or damage.

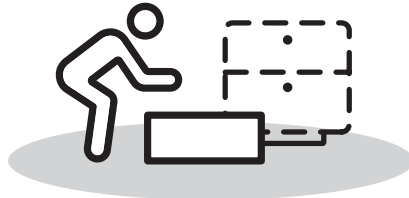
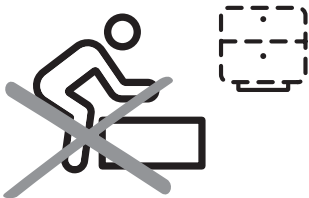

Suitable Location

Assembling near the area of the intended location is highly recommended.



Sufficient Space

Make sure you have enough space to move around during the assembly.

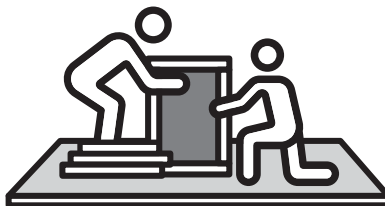

Avoid Scratches

Use cardboard, blankets or a carpeted area while assembling furniture to prevent to prevent scratches and damages.

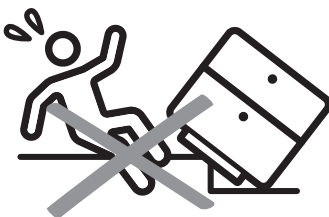

Flat Surface

Make sure the furniture rests on a flat and level surface with each leg evenly touching the floor.

ASSEMBLY AND CARE ADVICE



FAILURE TO FOLLOW THE GUIDELINES BELOW MAY RESULT IN INJURY AND/OR PROPERTY DAMAGE.



Position each part correctly and insert screws or bolts into their respective holes.

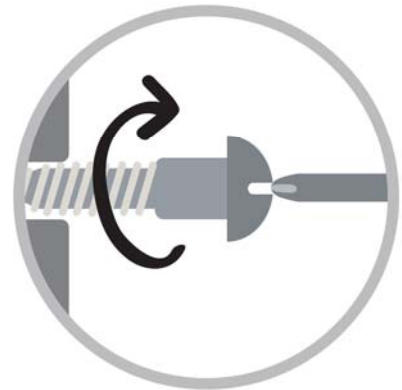

Turn clockwise to tighten and only tighten when step is completed or when instructed to do so.



Use the appropriate hand tools or power tools for assembly. Select steps, such as tightening screws and/or bolts, may require hand tools to avoid causing damage during assembly.



Save the instructions and store any supplied tools for later maintenance.

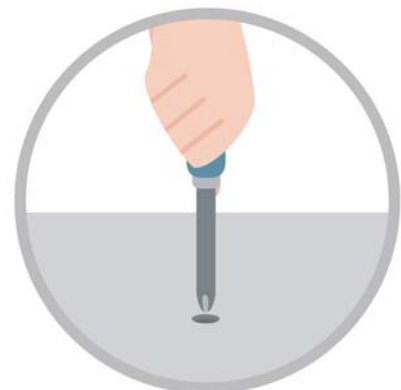

After two weeks, check and tighten any loose hardware and repeat again every six months thereafter.

IT IS THE USER'S RESPONSIBILITY TO MAINTAIN THE FURNITURE. THE HARDWARE MAY LOOSEN OVER TIME AND MAY CAUSE THE FURNITURE TO BE WOBBLY AND UNABLE TO SUPPORT ITS INTENDED WEIGHT CAPACITY. THIS MAY LEAD TO COLLAPSE AND MAY CAUSE SERIOUS INJURY.

ROUND DINING TABLE



- Please keep instructions for future reference.
- Check the quantity and irregularity of parts and hardware before you start.

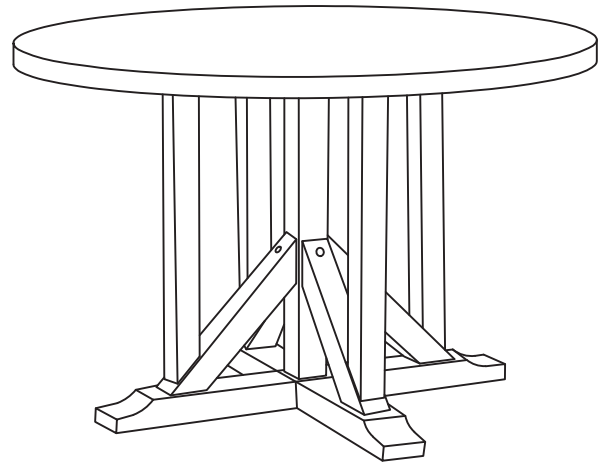

PARTS

#1 1pc

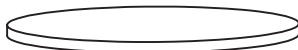
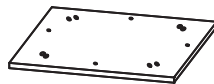

Table Top

#2 1pc



Mounting Plate

#3 1pc

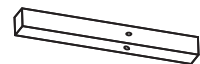

Center Leg

#4 4pcs

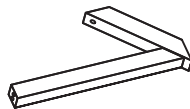

Leg Assembly

#5 1pc



Lower Leg Base

#6 1pc



Upper Leg Base

HARDWARE

#A 13pcs



M6 x 35MM Bolt

#B 4pcs



M6 x 50MM Bolt

#C 8pcs



M6 x 70MM Bolt

#D 25pcs



M6 x 13MM Spring Washer

#E 4pcs



M6 x 14MM Flat Washer

#F 21pcs



M6 x 19MM Flat Washer

#G 4pcs



Wood Button

#H 4pcs













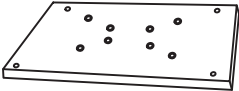
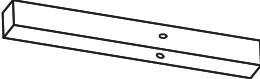

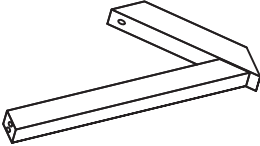
M6 Adjuster Base Leg

#I 1pc



M4 Allen Wrench

is packed in 2 cases

Designation		Part	Hardware
Table Top	# 1		
Mounting Plate	# 2		
Center Leg	# 3		 #A x 13pcs
Leg Assembly	# 4		 #B x 4pcs  #C x 8pcs  #D x 25pcs  #E x 4pcs
Lower Leg Base	# 5		 #F x 21pcs  #G x 4pcs
Upper Leg Base	# 6		 #H x 4pcs  #I x 1pc

ASSEMBLY INSTRUCTIONS

1

- Part #3 x1pc
- Part #4 x4pcs
- Hardware #B x4pcs
- Hardware #D x4pcs
- Hardware #E x4pcs
- Hardware #I x1pc

Align the Leg Assembly (#4) to the Center Leg (#3) then secure by using bolts (#B) then with washers (#D,E).

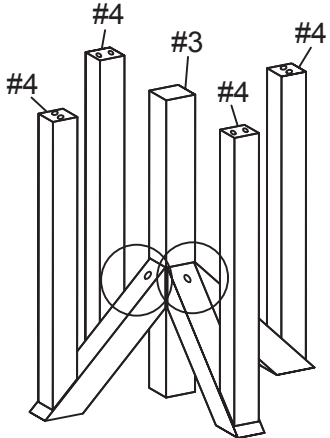
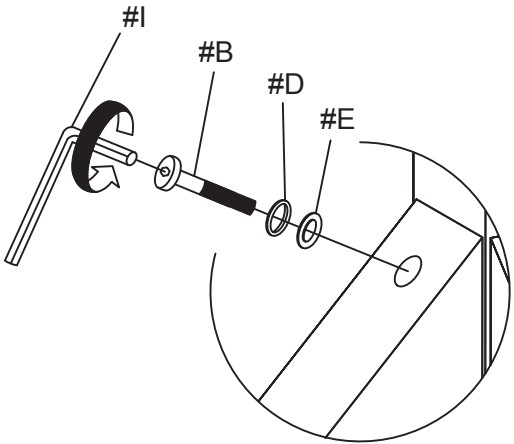

2

- Part #1 x1pc
- Part #2 x1pc
- Hardware #I x1pc

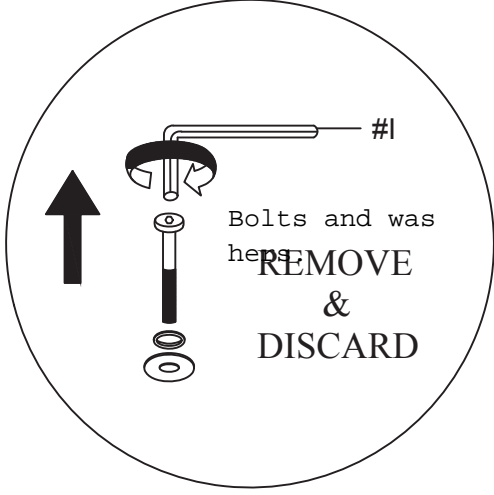
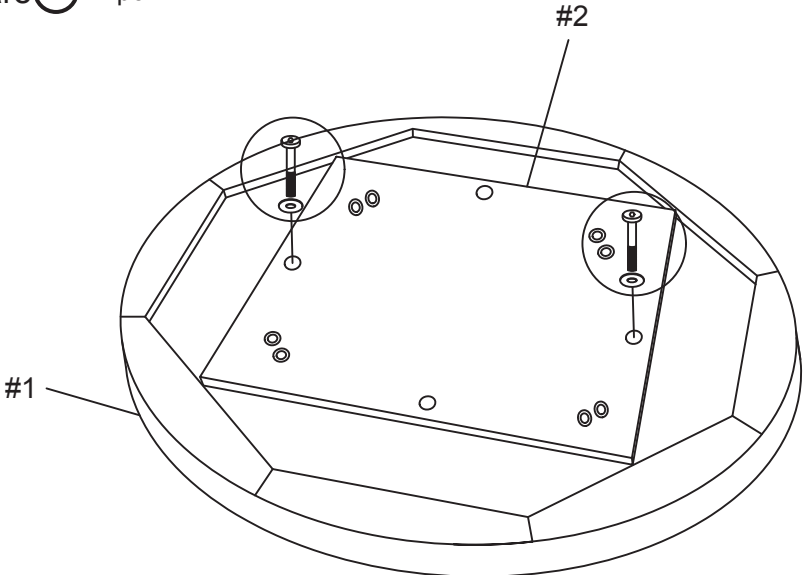

ASSEMBLY INSTRUCTIONS

3

- Part #2 x1pc
- Hardware #A x8pcs
- Hardware #D x8pcs
- Hardware #F x8pcs
- Hardware #I x1pc

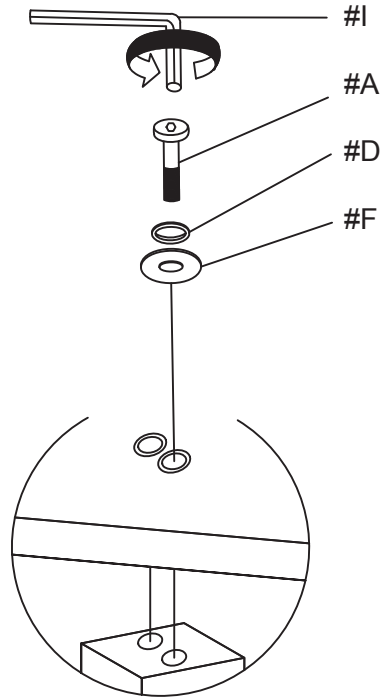

Align the Mounting Plate (#2) to the Leg Assembly (#4), then Secure by using bolts (#A) then with washers (#D,F).

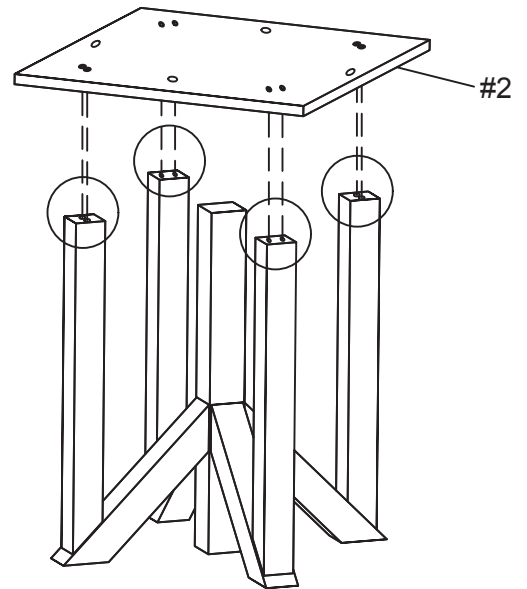

4

- Part #5 x1pc
- Part #6 x1pc
- Hardware #C x8pcs
- Hardware #D x8pcs
- Hardware #F x8pcs
- Hardware #I x1pc

Lower Leg Base (#5) combine together Upper Leg Base (#6), align to the Leg Assembly (#4) then secure by using bolts (#C) then with washers (#D,F).

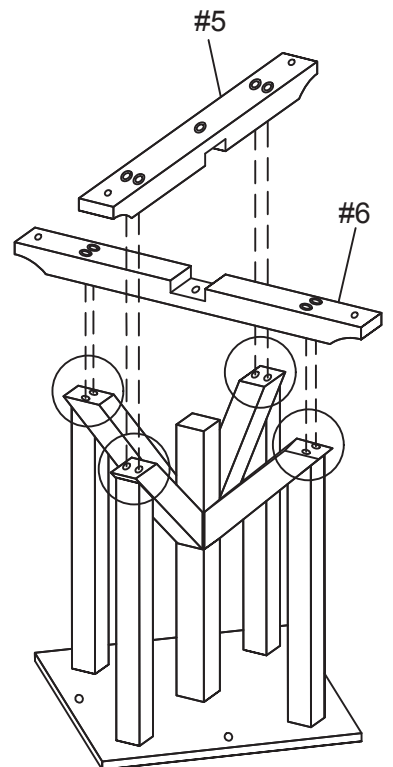
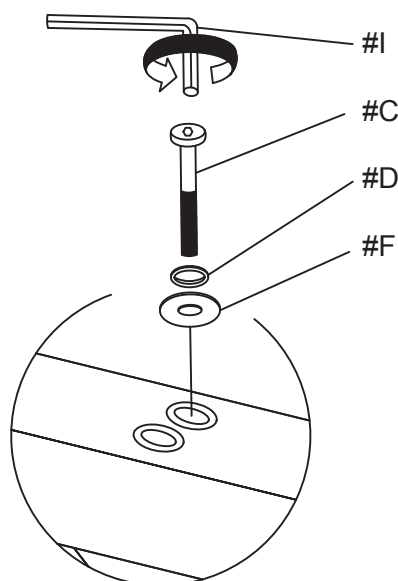

ASSEMBLY INSTRUCTIONS

5

Part #1 x1pc

Hardware #A x4pcs

Hardware #D x4pcs

Hardware #F x4pcs

Hardware #I x1pc

Align the Mounting Plate (#2) to the Table Top (#1), then secure by using bolts (#A) then with washers (#D,F).

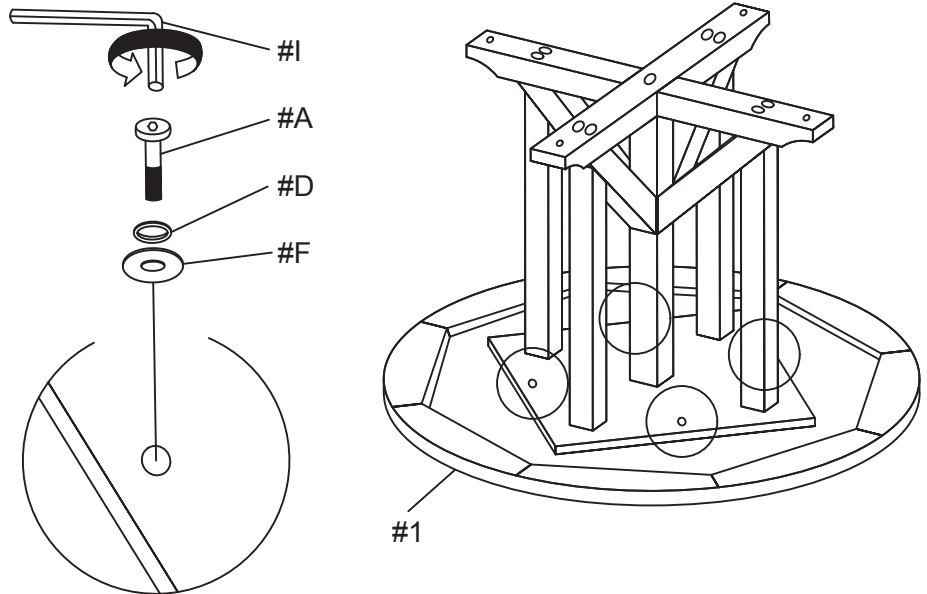

6

Hardware #A x1pc

Hardware #D x1pc

Hardware #F x1pc

Hardware #H x4pcs

Hardware #I x1pc

Lower Leg Base and Upper Leg Base (#5,6) use bolts (#A) then with washers (#D,F), then using adjuster (#H).

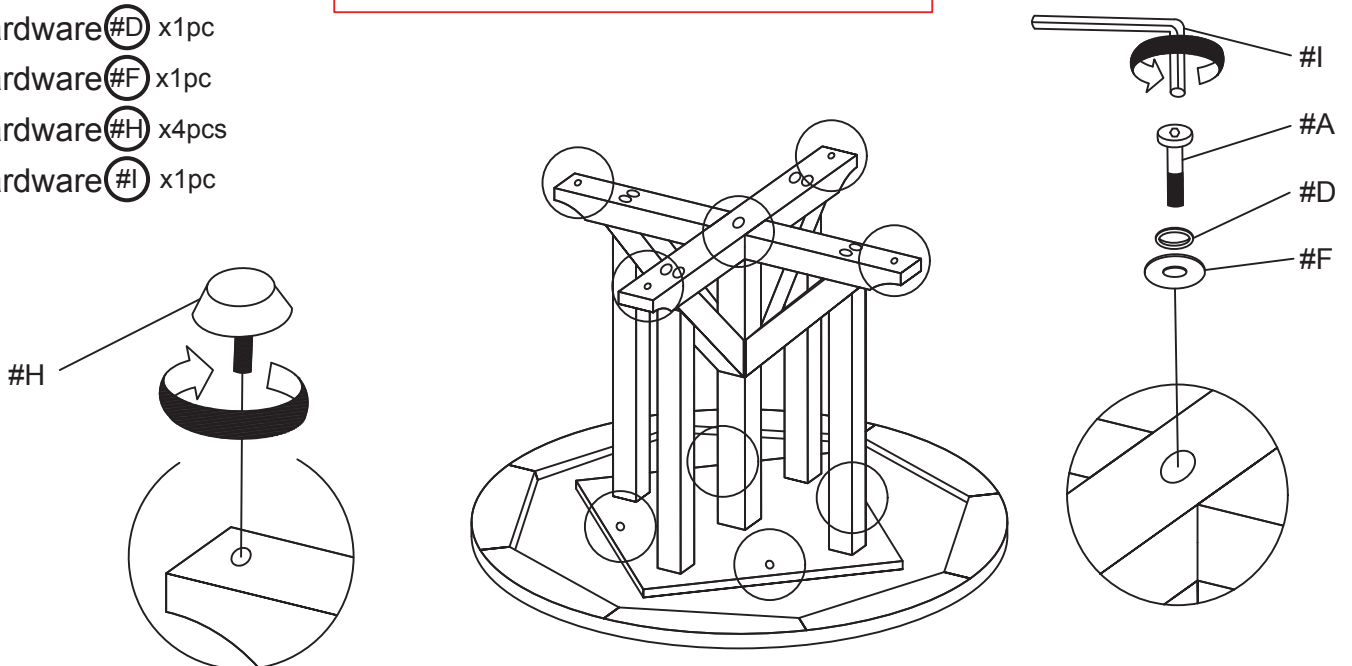

ASSEMBLY INSTRUCTIONS

7

Hardware  x4pcs

Plug the holes with Wood Button(#G).

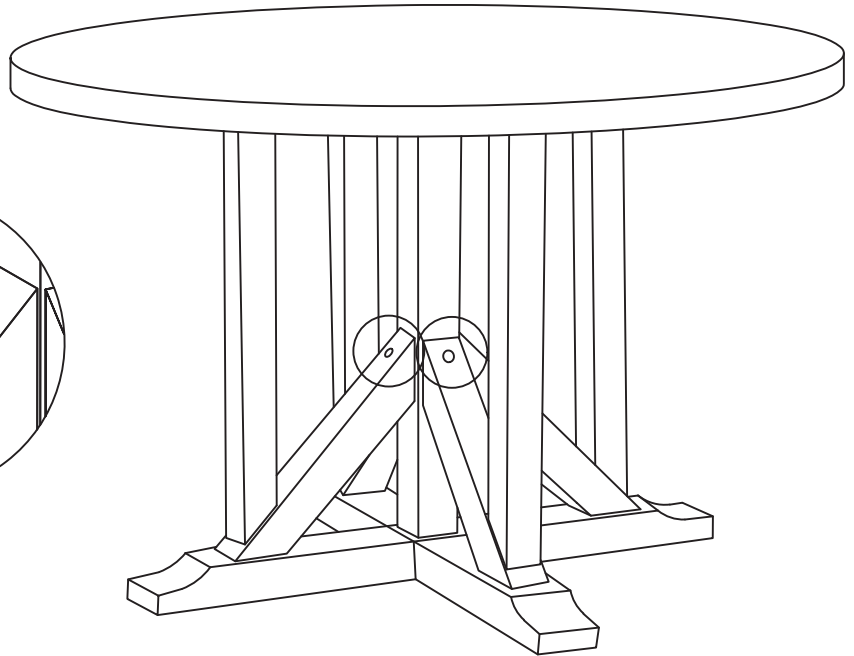
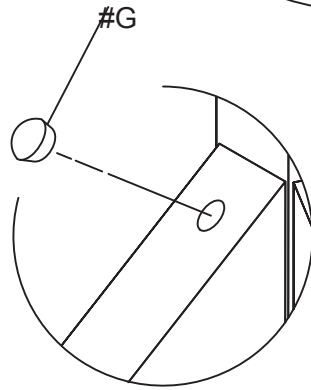

8

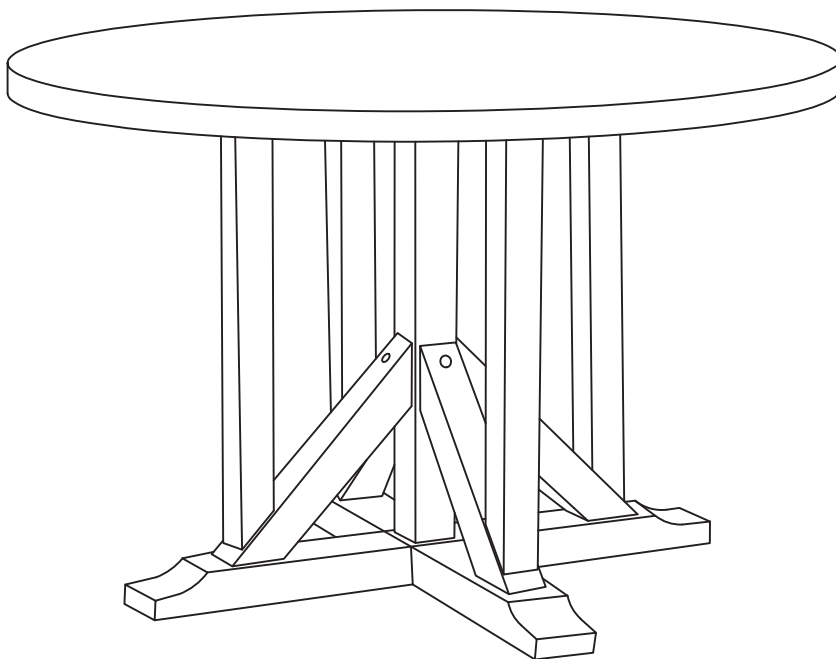

ASSEMBLY COMPLETED



Please ensure the furniture rests on an even and flat surface. If the product wobbles or feels loose, double-check all bolts and/or screws are properly tightened and secured.



Keep this handy!

Please retain this instruction manual and any order-related information for future reference.



Lift, don't drag!

To avoid damage to product please always LIFT the product when transporting or adjusting the placement.