

NOTICE

*Please make sure that you have all parts indicated and they are in good condition before you begin assembly of this item. Refer to part list and hardware list below for guidance.

*This item should be assembled on a soft surface to prevent scratching the finish during assembly.

*This item may require periodic tightening.

*If you are having difficulty, our friendly Customer Care team is always here to help.

PREPARATION

*Before beginning assembly of product, make sure all parts are present. Compare parts with part contents list and hardware contents list.

*If any part is missing or damaged, do not attempt to assemble the product.

*Estimated Assembly Time: 120 minutes.

*Tools Required for Assembly (included): Allen Key

CARE AND MAINTENANCE

We felt pads should always be applied to areas of furniture which make direct contact with flooring, said application will prevent damage to the furniture and or surfaces on which the furniture lies. Objects placed on articles of furniture should rest on non abrasive material as to prevent damage to the wood finish. Objects whose composition consists of plastic and rubber are known to discolor and damage the wood surfaces on which they rest. Wipe up spills immediately and avoid common hazards such as hot dishes, harsh solvents and abrasives. Cleaning should be done with a soft lint free cotton cloth dampened with water or furniture polish. On highly used surfaces we recommend applying a quality paste wax which should be used on a regular basis to provide additional protection from scratches and spills. How often you apply the wax depends on how much wear the furniture receives.

Part List

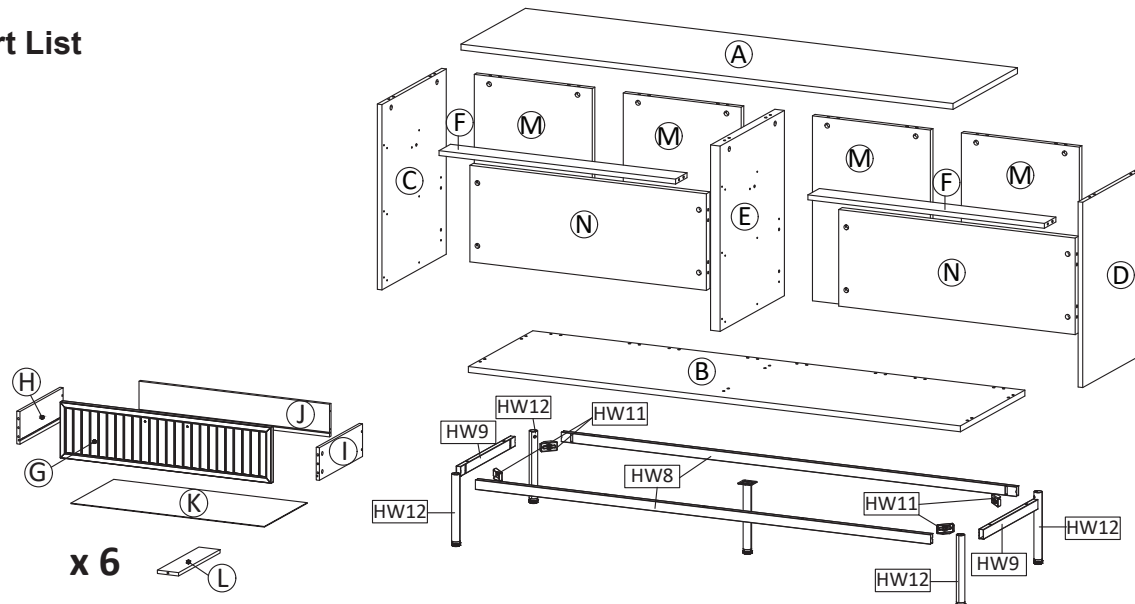

Installation & Assembly

Product Dimensions: 63.07"Wx18.54"Dx32.36"H

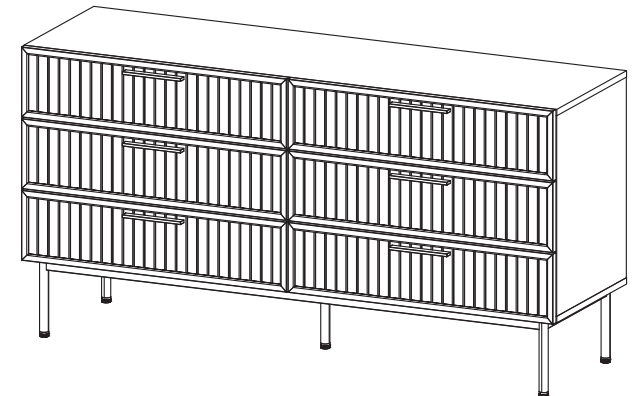

WARNING :











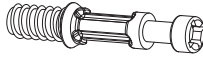

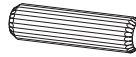

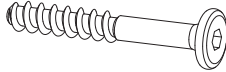
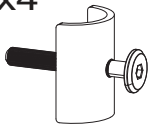
WEIGHT CAPACITY: 104 LBS.

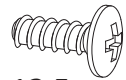
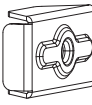
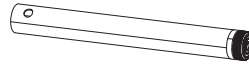
DRAWER LOAD CAPACITY: 35 LBS

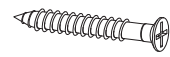
Warning : Do not stand on chest.

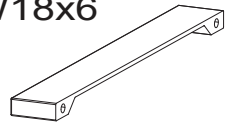
Warning : Do not over torque bolts.

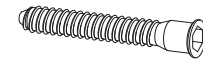
Hardware List

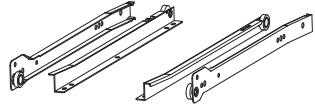
<p>HW1x56</p>  <p>∅ 6 x 35 mm</p>	<p>HW2x26</p>  <p>∅ 15 mm</p>	<p>HW3x30</p>  <p>∅ 12 mm</p>	<p>HW4x40</p>  <p>∅ 8 x 30 mm</p>	<p>HW5x12</p>  <p>∅ 6 x 30 mm</p>
<p>HW6x14</p>  <p>M 6.4 x 45 mm</p>	<p>HW7x4</p> 	<p>HW8x2</p> 	<p>HW9x2</p> 	<p>HW10x4</p>  <p>M 4.5 x 12.5 mm</p>
<p>HW11x4</p> 	<p>HW12x4</p> 	<p>HW13x36</p>  <p>M 6 x 10.5 mm</p>	<p>HW14x36</p>  <p>M 3.5 x 13 mm</p>	<p>HW15x36</p>  <p>M 8 x 39 mm</p>
<p>HW16x24</p> 	<p>HW17x24</p>  <p>M 3.5 x 15.5 mm</p>	<p>HW18x6</p> 	<p>HW19x12</p>  <p>M 4 x 22 mm</p>	<p>HW20x14</p>  <p>M 7 x 50 mm</p>
<p>HW21x2</p> 	<p>HW LM21A1x1</p> 	<p>HW RM35Ax6</p> 		

Part List & HW For Multi-Box Items

Piece	Description	Qty	Carton Call
A	Top Board	1	1 of 2
B	Bottom Board	1	1 of 2
C	Side Board Left	1	2 of 2
D	Side Board Right	1	2 of 2
E	Center Board	1	2 of 2
F	Support Board 1	2	1 of 2
G	Front Drawer	6	2 of 2
H	Side Drawer Left	6	2 of 2
I	Side Drawer Right	6	2 of 2
J	Back Drawer	6	1 of 2
K	Bottom Drawer	6	1 of 2
L	Support Drawer	6	1 of 2
M	Back Board	4	2 of 2
N	Support Board 2	2	1 of 2

Piece	Description	Qty	Carton Call
HW1	Cambolt	56	2 of 2
HW2	CamLock Big	26	2 of 2
HW3	CamLock Small	30	2 of 2
HW4	Dowel Big	40	2 of 2
HW5	Dowel Small	12	2 of 2
HW6	Screw M 6.4 x 45 mm	14	2 of 2
HW7	Support Corner Brace&Screw M 6 x 40 mm	4	2 of 2
HW8	Support Metal Leg 1	2	1 of 2
HW9	Support Metal Leg 2	2	1 of 2
HW10	Screw M 4.5 x 12.5 mm	4	2 of 2
HW11	Corner Brace	4	2 of 2
HW12	Leg	4	2 of 2
HW13	Screw M 6 x 10.5 mm	36	2 of 2
HW14	Screw M 3.5 x 13 mm	36	2 of 2
HW15	Screw M 8 x 39 mm	36	2 of 2
HW16	Wedge	24	2 of 2
HW17	Screw M 3.5 x 15.5 mm	24	2 of 2
HW18	Handle	6	2 of 2
HW19	Screw M 4 x 22 mm	12	2 of 2
HW20	Screw M 7 x 50 mm	14	2 of 2
HW21	Allen Key	2	2 of 2
HW LM21A1	Center Leg	1	2 of 2
HW RM35A	Drawer Runner	6	2 of 2

PREPARATION

*Before beginning assembly of product, make sure all parts are present. Compare parts with part contents list and hardware contents list.

*If any part is missing or damaged, do not attempt to assemble the product.

*Estimated Assembly Time: 120 minutes.

*Tools Required for Assembly (included): Allen Key

*If you are having difficulty, our friendly Customer Care team is always here to help.

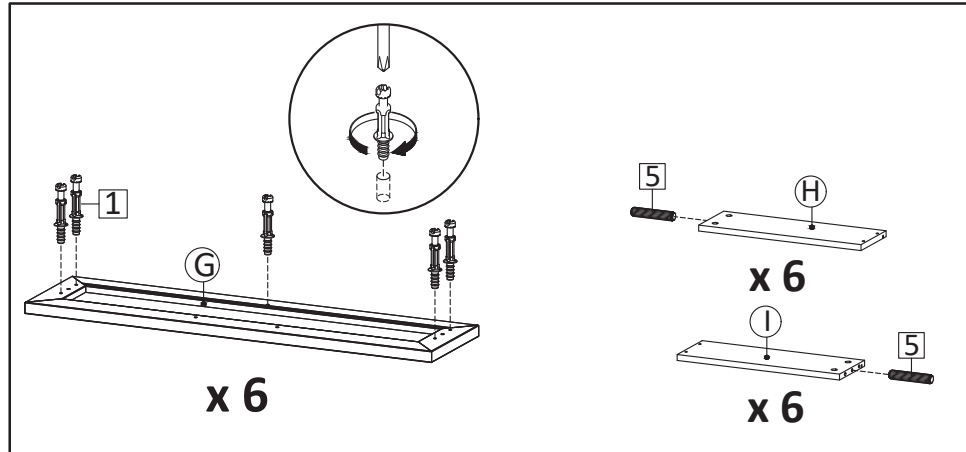

STEP1: Insert Cambolt (HW1) into Front Drawer (G). Insert Dowel Small (HW5) into Side Drawers (H&I).

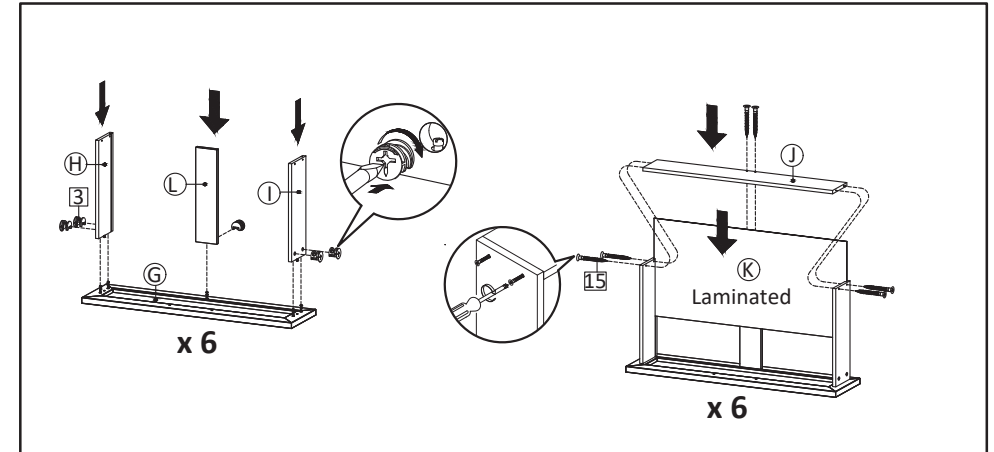

STEP2: Combine Side Drawers (H&I) and Support Drawer (L) into Front Drawer (G) then tighten Camlock Small (HW3) using screwdriver. Insert Bottom Drawer (K) with laminated face facing upward then put Back Drawer (J) and secure with Screw M8x39mm (HW15).

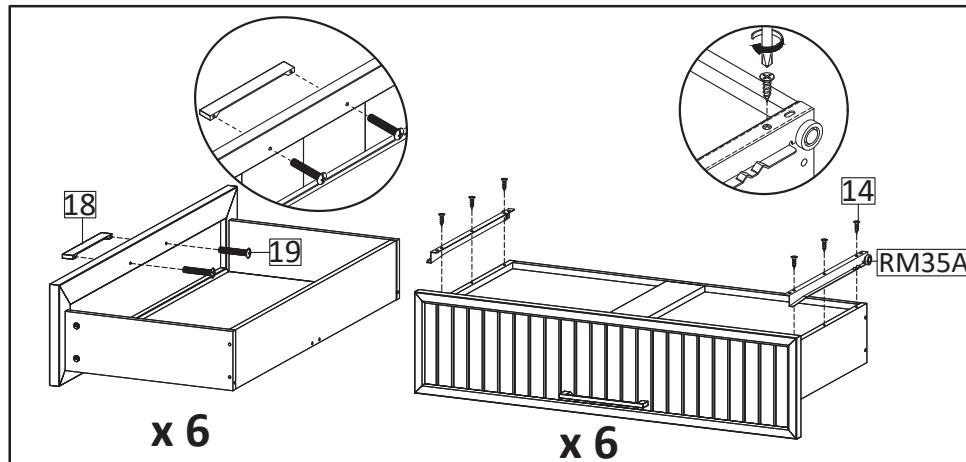

STEP3: Use Screw M4x22mm (HW19) to attach Handle (HW18) to the Front Drawer. Install the Drawer Runner (HW RM35A) into position as shown in picture. Secure with screws M3.5x13mm (HW14).

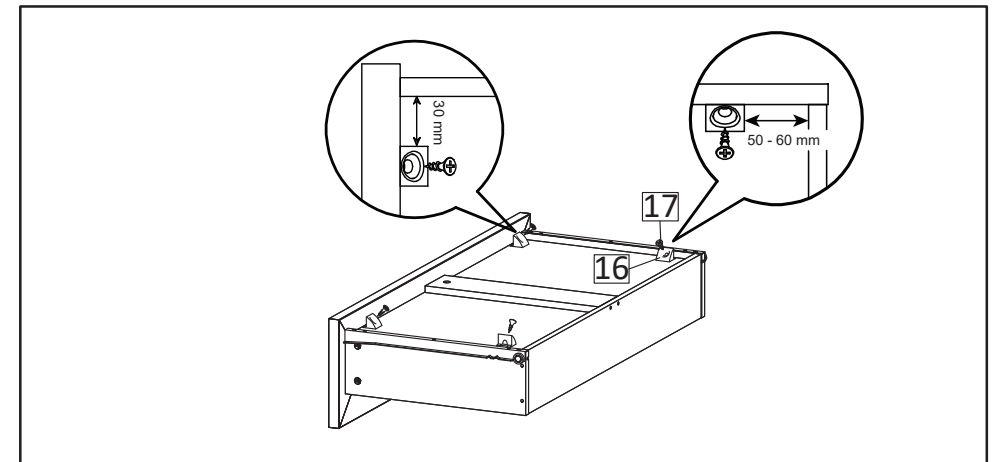

STEP4: Insert the Screw M3.5x15.5mm (HW17) and Wedge (HW16) into the bottom of the drawer according to the picture.

PREPARATION

*Before beginning assembly of product, make sure all parts are present. Compare parts with part contents list and hardware contents list.

*If any part is missing or damaged, do not attempt to assemble the product.

*Estimated Assembly Time: 120 minutes.

*Tools Required for Assembly (included): Allen Key

*If you are having difficulty, our friendly Customer Care team is always here to help.

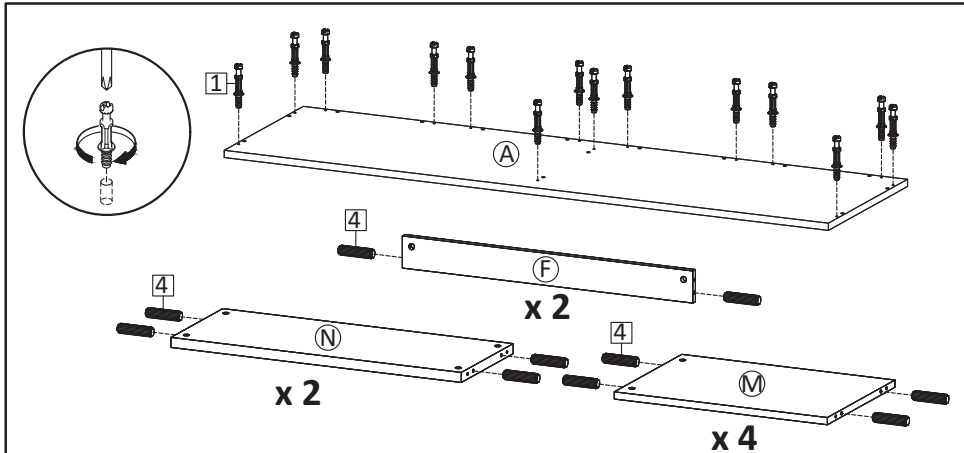

STEP5: Insert Cambolt (HW1) into Top Board (A). Insert Dowel Big (HW4) into Support Board 1 (F), Support Board 2 (N) and Back Boards (M) as figure.

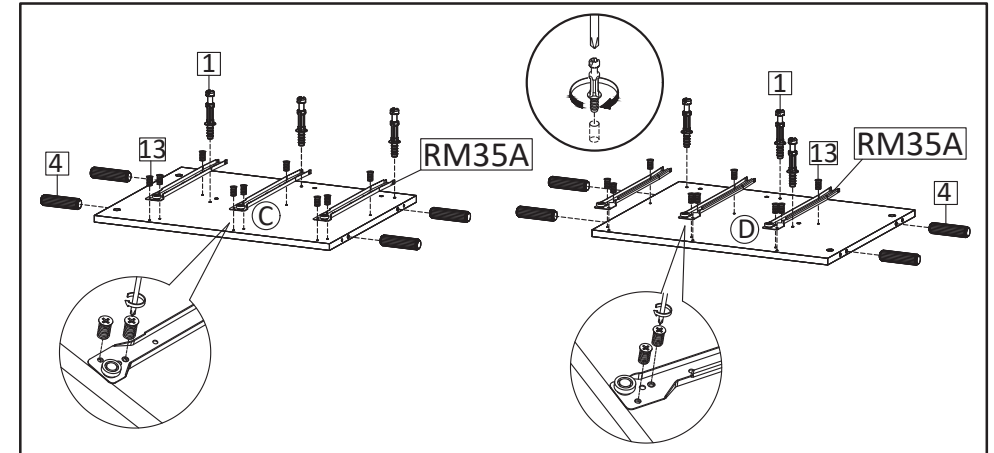

STEP6: Insert Cambolt (HW1) into the Side Board Left (C) and Side Board Right (D), then tighten using a screwdriver. Next, install Part of Drawer Runner (HW RM35A) and secure it with the Screw M6 x 10.5 mm (HW13), tightening with a screwdriver. Then insert Dowel Big (HW4) into the top and bottom sides of the components.

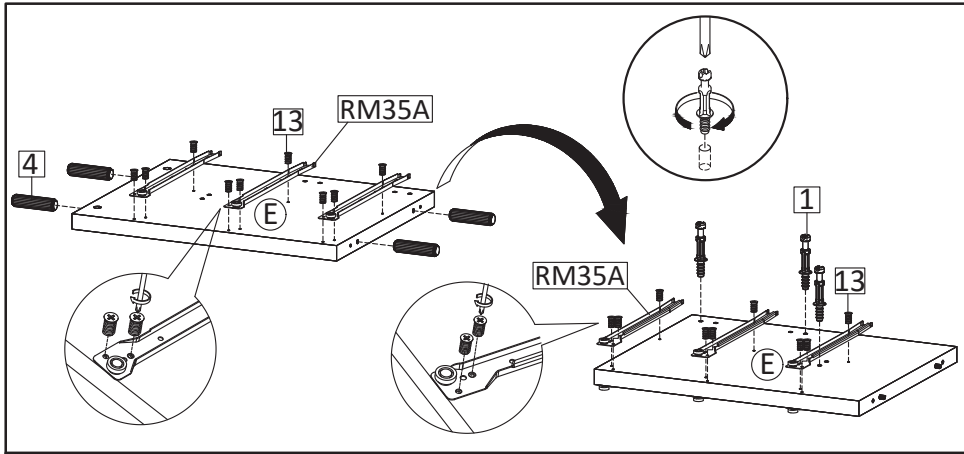

STEP7: Install Part of Drawer Runner (HW RM35A) to Center Board (E), secure it with the Screw M6 x 10.5 mm (HW13), then tighten using a screwdriver. Then insert Dowel Big (HW4) into the top and bottom sides of the components. Next, Flip the Center Board (E) to the other side, repeat the process for installation part of Drawer Runner, then insert Cambolt (HW1) tighten using a screwdriver.

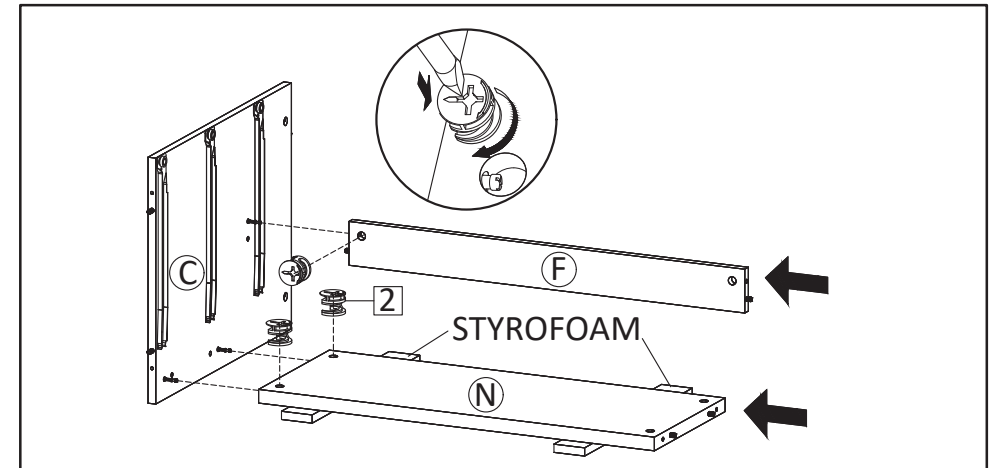

STEP8: Attach Support Board 1 (F) and Support Board 2 (N) into Side Board Left (C), Secure with Camlock Big (HW2) and tighten it using screwdriver as figure.

PREPARATION

*Before beginning assembly of product, make sure all parts are present. Compare parts with part contents list and hardware contents list.

*If any part is missing or damaged, do not attempt to assemble the product.

*Estimated Assembly Time: 120 minutes.

*Tools Required for Assembly (included): Allen Key

*If you are having difficulty, our friendly Customer Care team is always here to help.

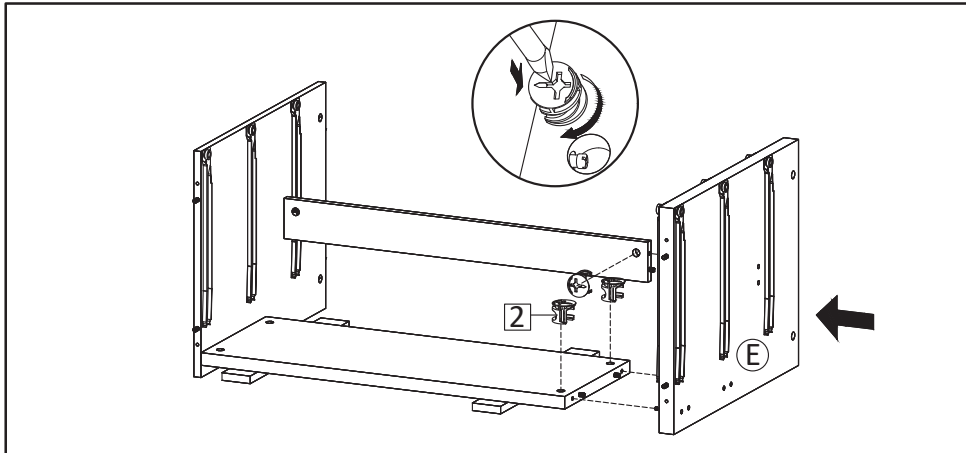

STEP9: Attach Center Board (E). Secure with Camlock Big (HW2) and tighten it using screwdriver as figure.

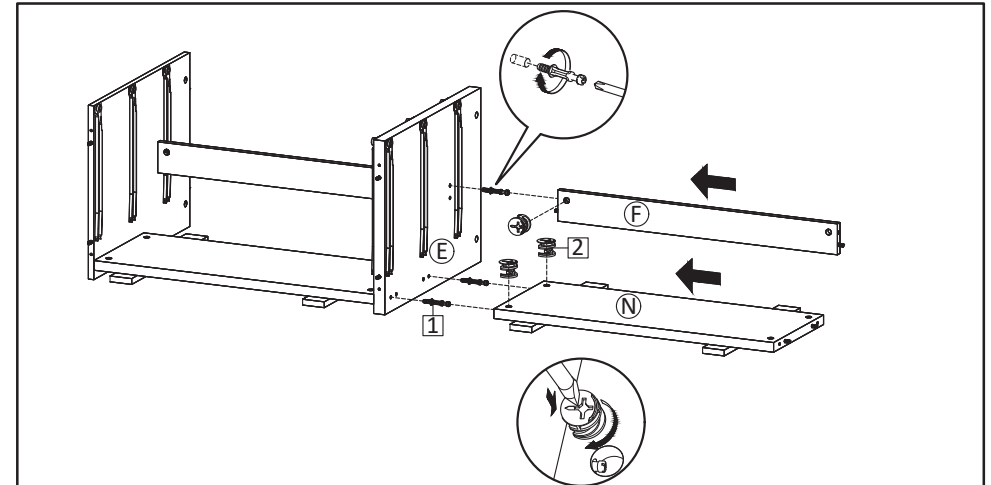

STEP10: Attach Support Board 1 (F) and Support Board 2 (N) into Center Board (E). Secure with Camlock Big (HW2) and tighten it using screwdriver as figure.

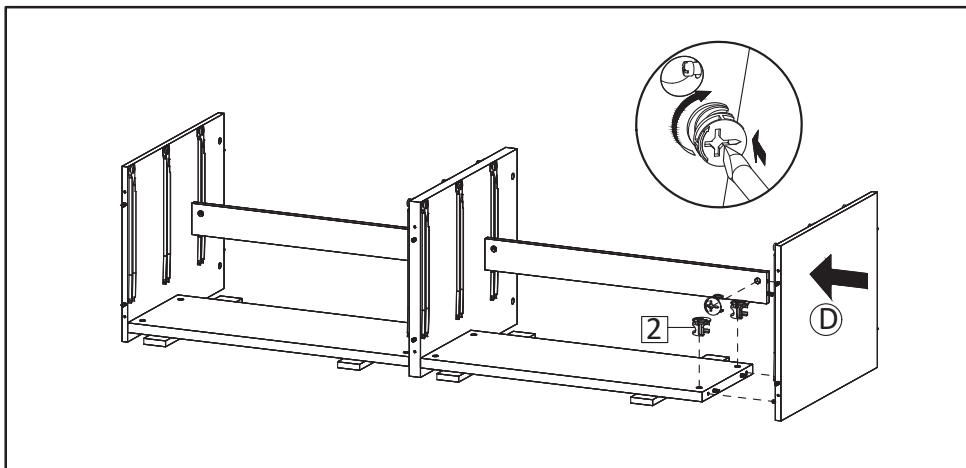

STEP11: Attach Side Board Right (D). Secure with Camlock Big (HW2) and tighten it using screwdriver as figure.

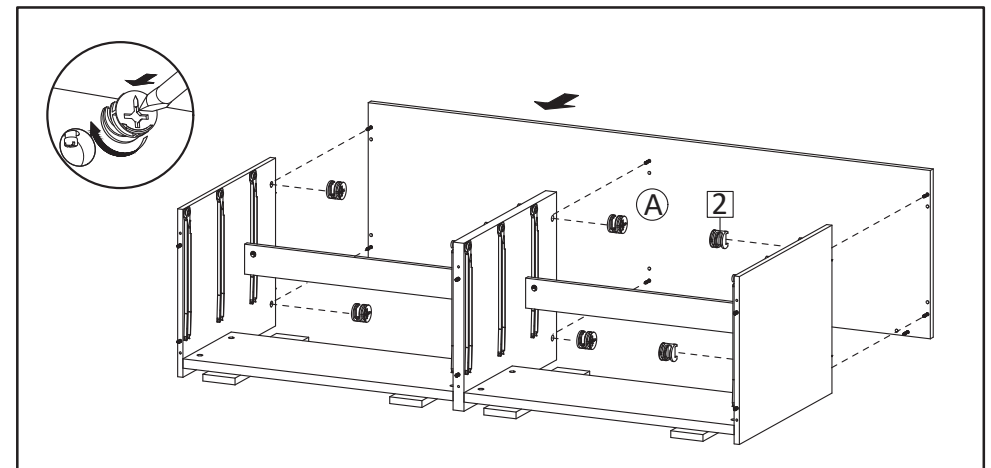

STEP12: Attach the Top Board (A) to the Body assembly Secure with Camlock Big (HW2) and tighten it using screwdriver as figure.

PREPARATION

*Before beginning assembly of product, make sure all parts are present. Compare parts with part contents list and hardware contents list.

*If any part is missing or damaged, do not attempt to assemble the product.

*Estimated Assembly Time: 120 minutes.

*Tools Required for Assembly (included): Allen Key

*If you are having difficulty, our friendly Customer Care team is always here to help.

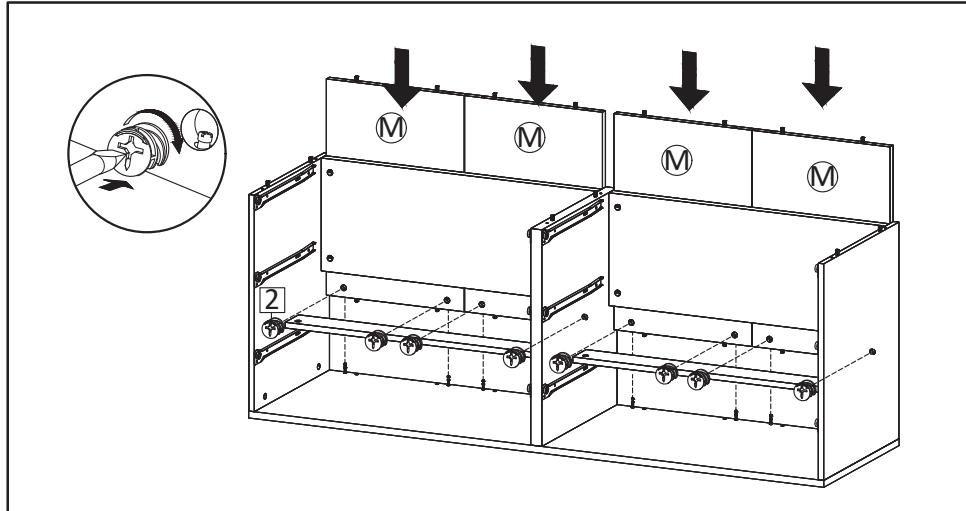

STEP13: Attach the Back Board (M) into Top Board (A) Secure with Camlock Big (HW2) and tighten it using screwdriver as figure.

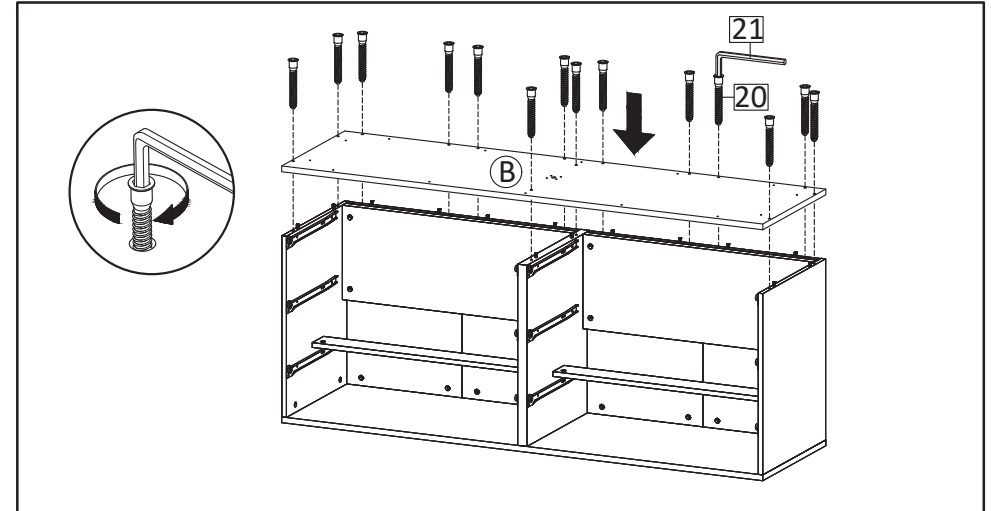

STEP14: Place Bottom Board (B), then secure with Screw M7x50mm (HW20),tighten screws using Allen Key (HW21).

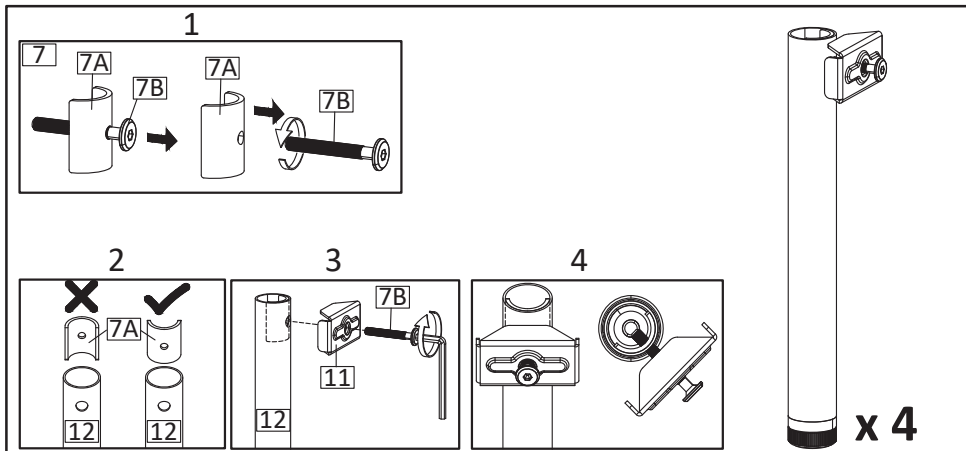

STEP15: First, remove the M6 x 40 mm screw (HW7B) from the Support Corner Brace (HW7A). Second, insert the Support Corner Brace (HW7A) into the Leg (HW12), ensuring that the hole in the Support Corner Brace aligns with the hole in the Leg. Third, insert the M6 x 40 mm screw (HW7B) into the hole in the Corner Brace (HW11), and insert it into the hole in the Leg, then tighten it slightly.

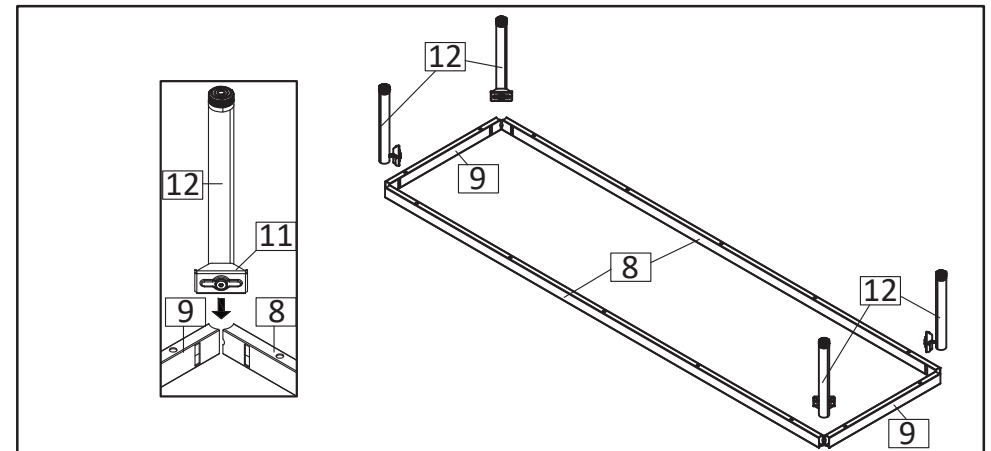

STEP16: Place Support Metal Leg 1 (HW8) and Support Metal Leg 2 (HW9) on the floor as shown in the image. Then, install the prepared leg (HW12). Ensure that the Corner Brace (HW11) hooks into the holes of Support Metal Leg 1 (HW8) and Support Metal Leg 2 (HW9).

PREPARATION

- *Before beginning assembly of product, make sure all parts are present. Compare parts with part contents list and hardware contents list.
- *If any part is missing or damaged, do not attempt to assemble the product.
- *Estimated Assembly Time: 120 minutes.
- *Tools Required for Assembly (included): Allen Key
- *If you are having difficulty, our friendly Customer Care team is always here to help.

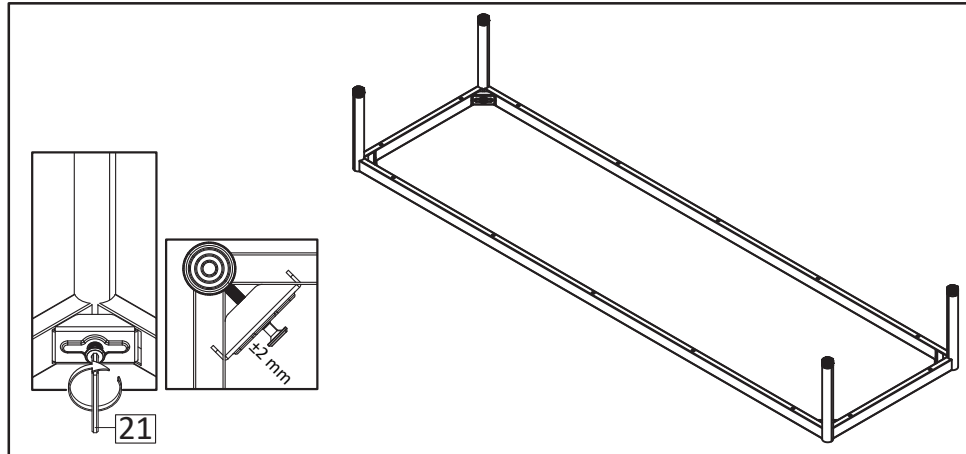

STEP17: Use the Allen Key (HW21) to slightly tighten the screws, just enough to hold the Support Metal Legs in place. Do not fully tighten them. Repeat this process for the remaining legs.

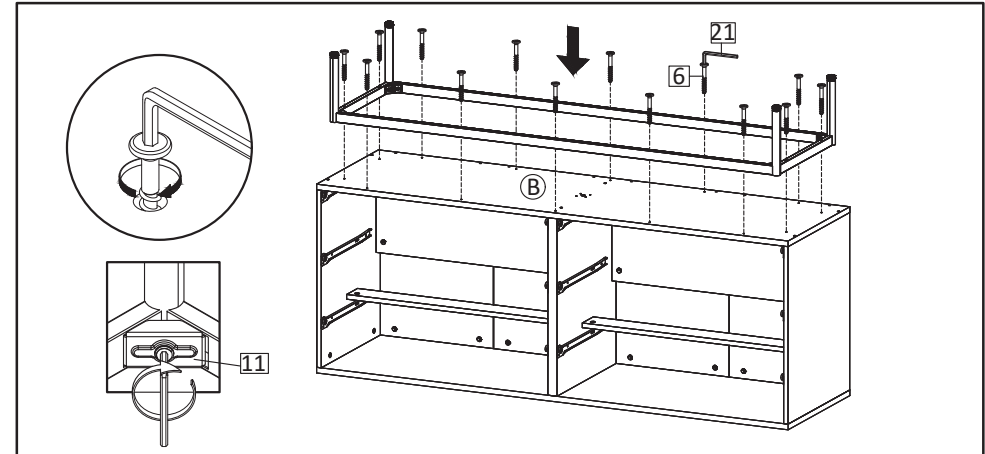

STEP18: Install the assembled leg unit from Step 16 onto the Bottom Board (B) by inserting Screw M6.4x45mm (HW6). Then, tighten all the screws on all corner braces (HW11) of the metal leg using an Allen Key (HW21).

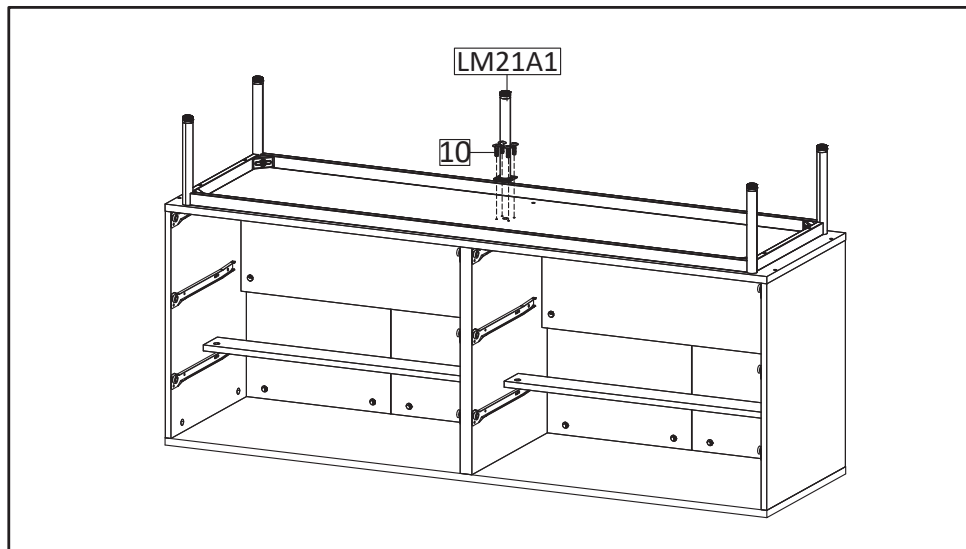

STEP19: Install Center Leg (HW LM21A1), secure with Screw M4.5x12.5mm (HW10) into Bottom Board as figure.

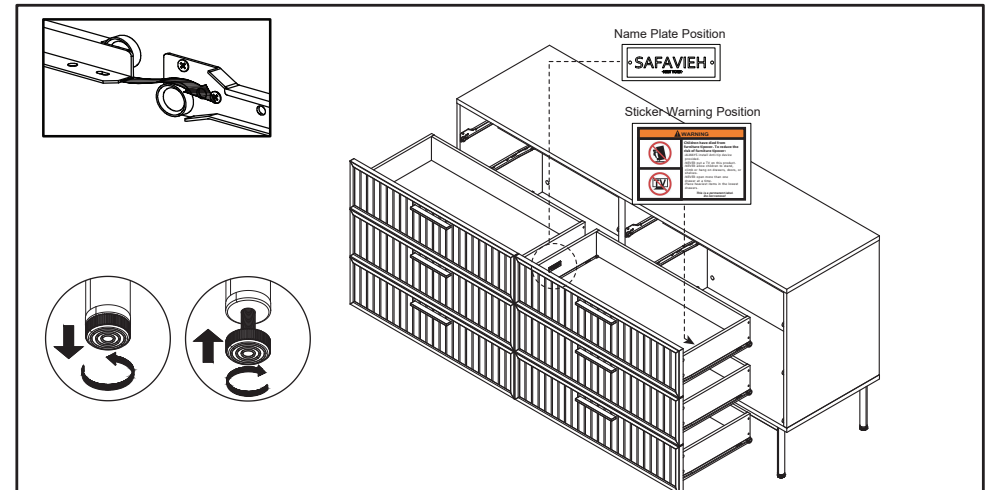

STEP20: Hold the sides of drawer, position the wheel of Drawer Runner at drawer back and the wheel of Drawer Runner at side boards, according to the image. Slide in the drawers one by one into the Sideboard. Place your furniture on level floor. The legs come with adjustable leveller, adjust it as needed until your furniture sit steady on the floor.

PREPARATION

- *Before beginning assembly of product, make sure all parts are present. Compare parts with part contents list and hardware contents list.
- *If any part is missing or damaged, do not attempt to assemble the product.
- *Estimated Assembly Time: 120 minutes.
- *Tools Required for Assembly (included): Allen Key
- *If you are having difficulty, our friendly Customer Care team is always here to help.

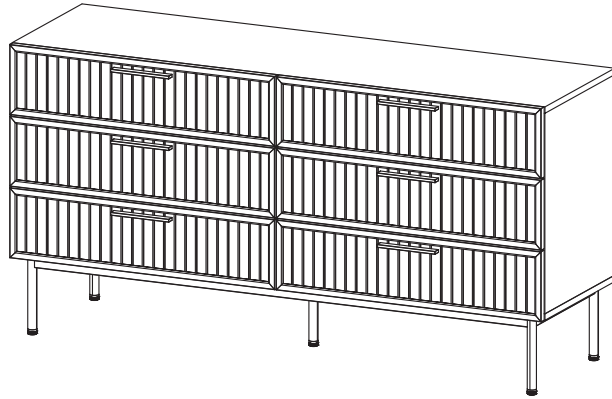

STEP21: Assembly is complete.

TIPPING RESTRAINTS KIT INSTALLATION GUIDANCE

Different wall materials require unique wall fasteners.

The wall plugs (AA2) and screws (AA3) are designed for fixing to concrete walls only.

Please consult your local hardware store to ensure you are using the correct hardware for your wall type.

