

Assembly Instructions

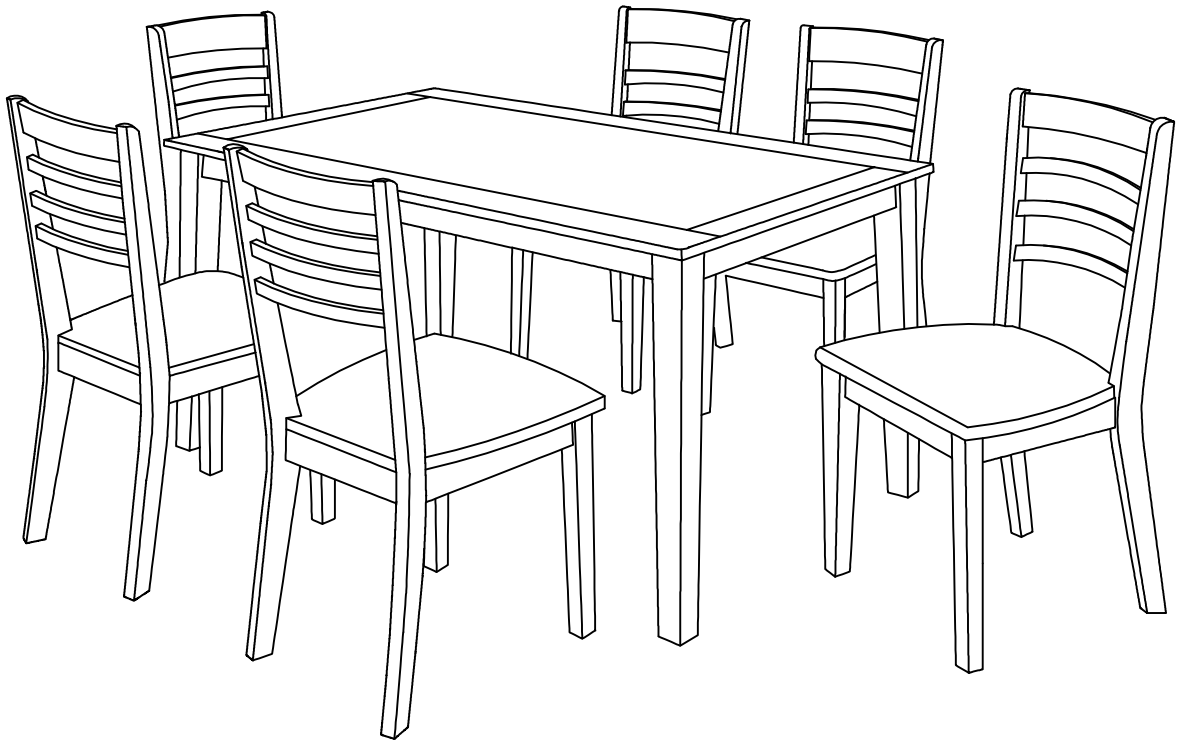

ASSEMBLY RATING

The Assembly Rating is a 5-point system that shows the degree of effort needed in assembling a specific product (with 1 being easy and 5 being difficult). For some products, two persons are recommended.

EASY  DIFFICULT

Tools Required For Assembly:

Allen Wrench

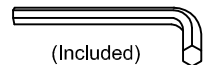

(Included)

Wrench

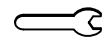

(Included)

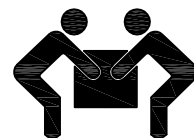

2 PERSONS RECOMMENDED

ASSEMBLY & CARE ADVICE

FOR YOUR FURNITURE TO LAST, CORRECT ASSEMBLY AND PROPER MAINTENANCE ARE NECESSARY. PLEASE FOLLOW THE INFORMATION PROVIDED BELOW TO FULLY ENJOY YOUR FURNITURE.

BASIC ASSEMBLY TECHNIQUES



When lock or spring washer is used in an assembly, please make sure the lock or spring washer is placed between the larger flat washer and the head of the screw or bolt.



Position each part correctly and insert screws or bolts into their respective holes by hand tighten or using the proper hand tool. Only tighten when step is completed or when instructed to do so.



Use cardboard or carpet area when assembling furniture to prevent scratches. Make sure the furniture rests on a flat and level surface with each leg evenly touching the floor.



Some furniture comes with height adjustment knobs underneath each leg. To lower or to raise each leg, you need to turn clockwise or counterclockwise, respectively.



Make sure all parts are properly aligned, then use the appropriate hand tool to completely tighten the bolts or screws. Do not use power tools and do not overtighten.



Save the instructions and store the Allen wrench or any supplied tool for later maintenance. After two weeks, check and tighten any loose hardware and repeat again every six months thereafter.

IT IS THE USER'S RESPONSIBILITY TO MAINTAIN THE FURNITURE. THE HARDWARE MAY LOOSEN OVER TIME AND MAY CAUSE THE FURNITURE TO BE WOBBLY AND UNABLE TO SUPPORT ITS INTENDED WEIGHT CAPACITY. THIS MAY LEAD TO COLLAPSE AND MAY CAUSE SERIOUS INJURY.

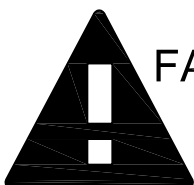

FAILURE TO FOLLOW THE GUIDELINES ABOVE MAY RESULT IN INJURY AND/OR PROPERTY DAMAGE.



Before you begin, please read Page 2 of "Assembly and Care Advice".

And remember, do not tighten until each step is completed or instructed.

Parts List



#1 x 1pc x 6
Backrest w/Legs

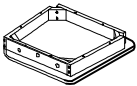

#2 x 1pc x 6
Seat Frame

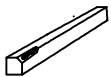

#3 x 2pcs x 6
Front Leg

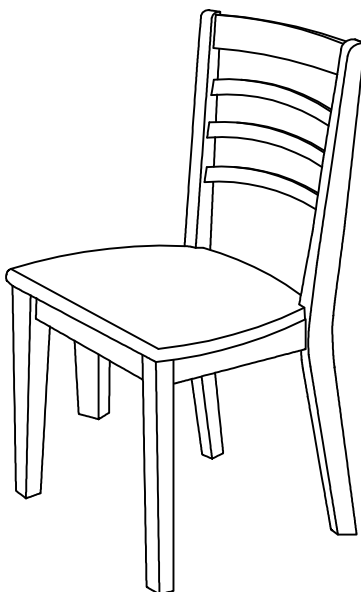

X6

Hardware List



#A x 4pcs x 6
Bolt 1/4"X3-1/8"



#B x 3pcs x 6
Bolt 1/4"X1-5/8"



#C x 11pcs x 6
Lock Washer



#D x 11pcs x 6
Flat Washer



#E x 4pcs x 6
Hex Nut

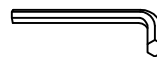

#F x 4pcs x 6
Allen Wrench M4



#G x 1pc x 6
Wrench



#1

#B x 3pcs
#C x 3pcs
#D x 3pcs

- I. Place the backrest with legs (#1) on a protected surface. Align the seat (#2) with the pre-drilled holes of the backrest with legs (#1).
 - II. Prepare bolt assembly by inserting FIRST the lock washer (#C) onto the bolt (#B) and then the flat washer (#D) onto the SAME bolt (#B), in that order.
 - III. Insert the bolt assembly through the pre-drilled holes in the center of the seat (#2) and secure the bolt using the Allen wrench (#F) to lock it with the seat (#2).
- Repeat the process with the remaining 2 bolts.

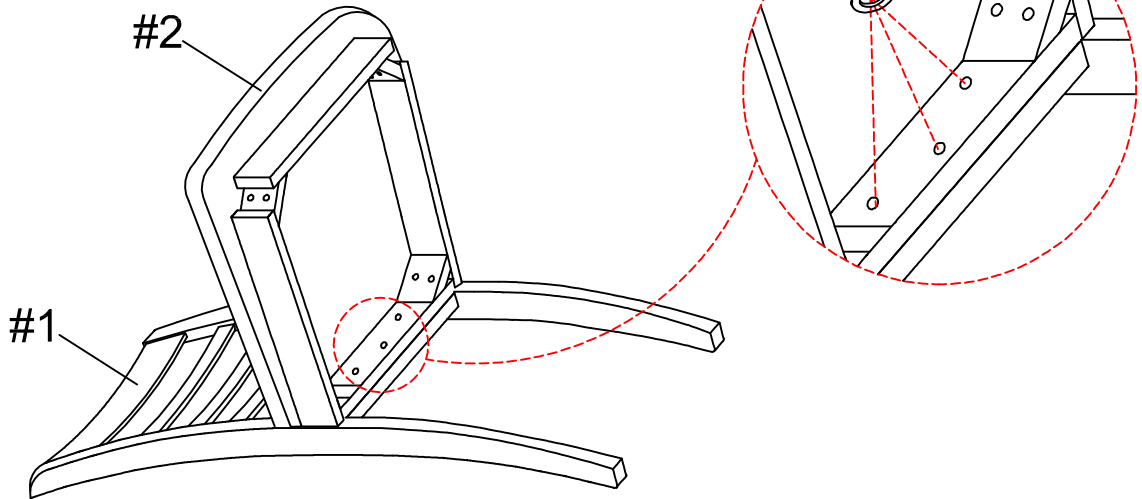

#2

#A x 4pcs
#C x 4pcs
#D x 4pcs

- I. Prepare bolt assembly by inserting FIRST the lock washer (#C) onto the bolt (#A) and then the flat washer (#D) onto the SAME bolt (#A), in that order.
- II. Insert the bolt assembly through the pre-drilled holes in the corner of the seat (#2) and secure the bolt using the Allen wrench (#F) to lock it. Repeat the process with the remaining 3 bolts.

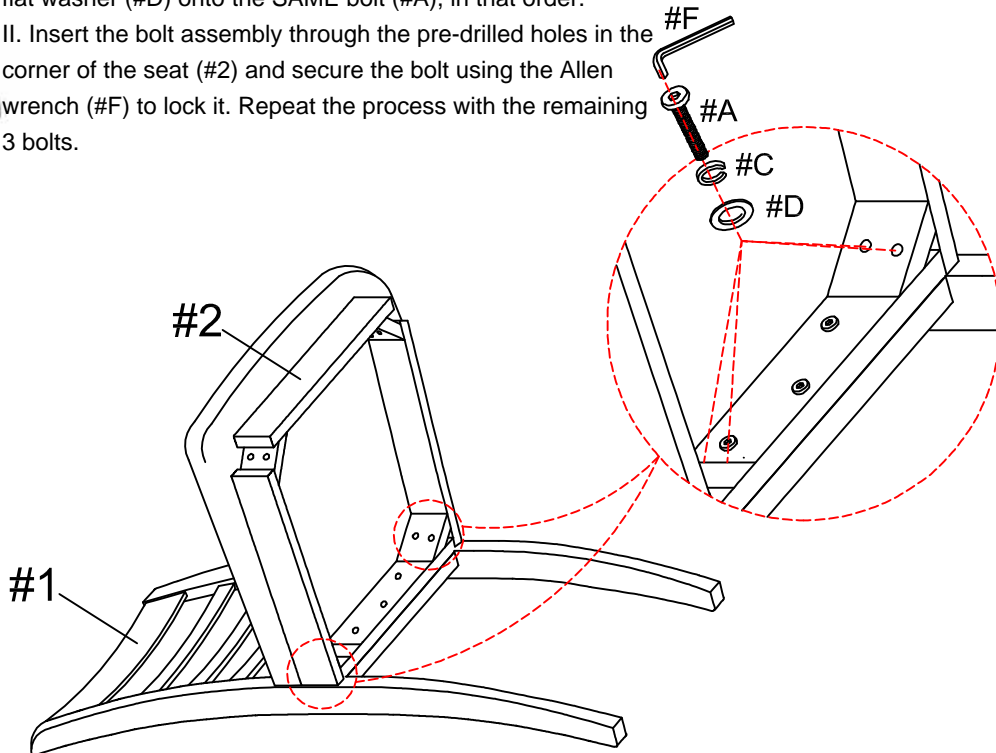



- I. Insert the front leg (#3) in the pre-drilled holes on the front corner of the seat (#2).
- II. Insert FIRST the flat washer (#D) then the lock washer (#C) and after that the hex nut (#E) onto the bolt connected to the leg (#3) using the wrench (#G). Repeat process on the other leg front (#3).
- III. Carefully turn the completed chair upright. Make sure the chair is rested on a flat surface and does not feel loose or wobbly. If it does, double check that everything is secured and properly tightened.

#C x 4pcs
#D x 4pcs
#E x 4pcs

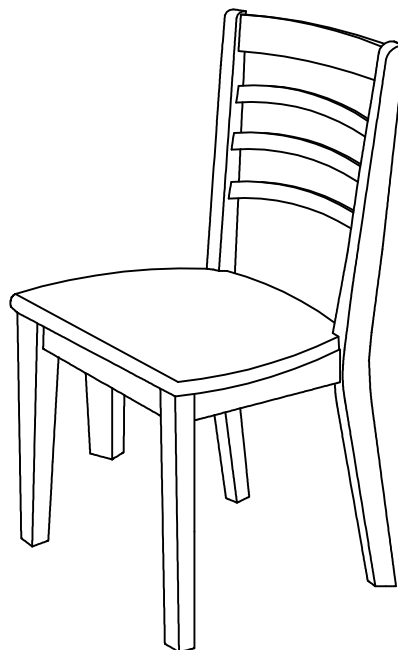
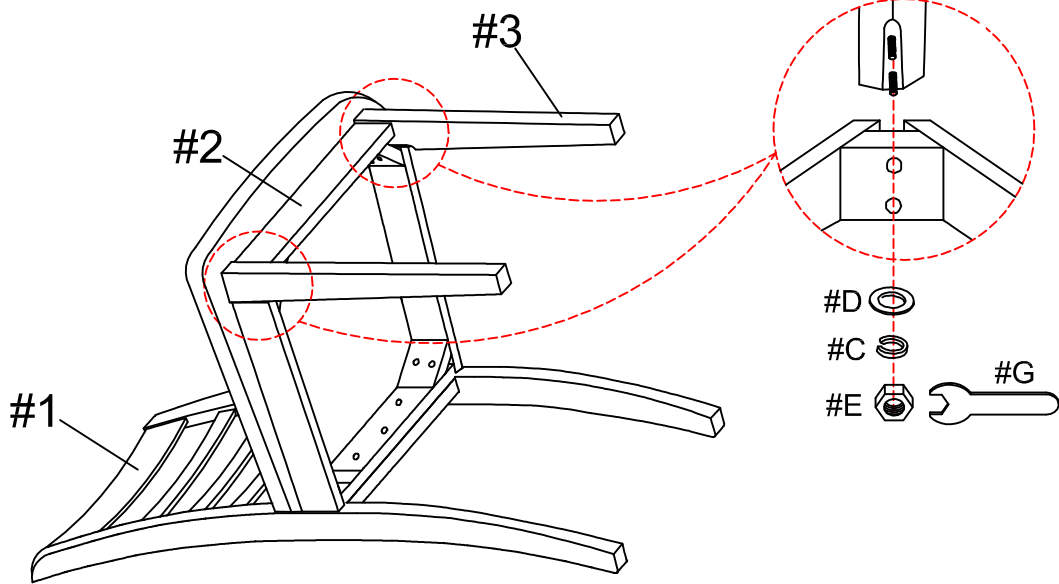

ASSEMBLY IS COMPLETED



Before you begin, please read Page 2 of "Assembly and Care Advice".

And remember, do not tighten until each step is completed or instructed.

Parts List

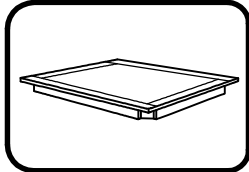

#1 x 1pc
Top Panel

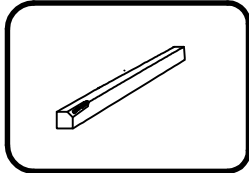

#2 x 4pcs
Leg

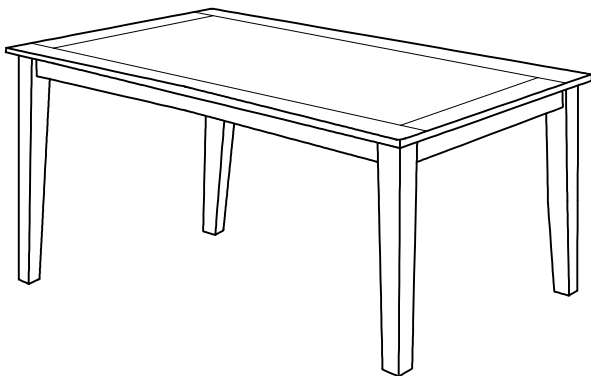

Hardware List

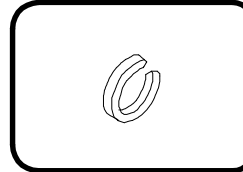

#A x 8pcs
Lock Washer

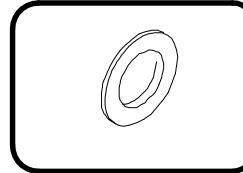

#B x 8pcs
Flat Washer

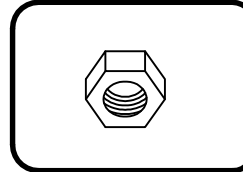

#C x 8pcs
Hex Nut

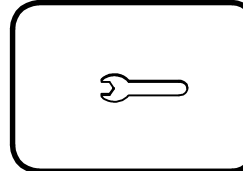

#D x 1pc
Wrench



- I. With the help of another person, carefully place the table top (#1) facing down on a protected surface.
- II. Align the 4 legs (#2) with the pre-drilled holes on the bottom corners of the table top (#1).
- III. Prepare 8 assemblies by inserting FIRST the flat washer (#B) onto the bolt and then the lock washer (#A) onto the SAME bolt and finally the hex nut (#C), in that order.
- IV. Secure assembly using the wrench (#D) to lock the legs (#2).

#A x 8pcs
#B x 8pcs
#C x 8pcs

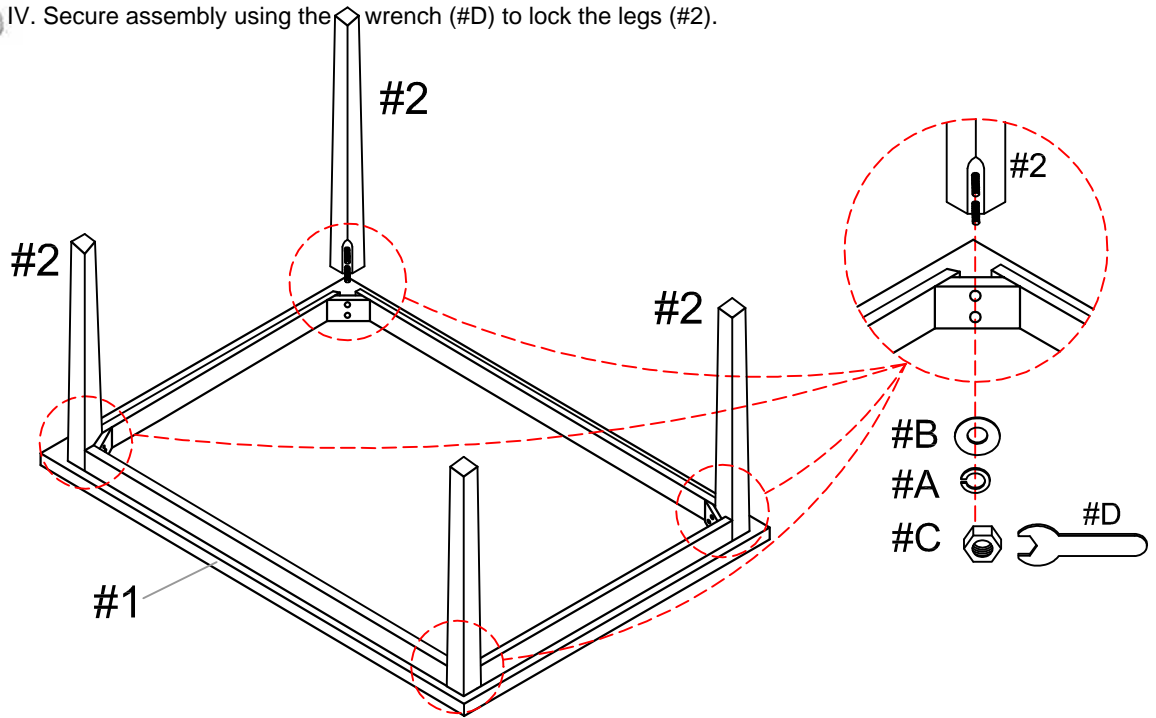

Carefully turn the completed table upright. Make sure the table is rested on a flat surface and does not feel loose or wobbly. If it does, double check that the bolts are secured and properly tightened.

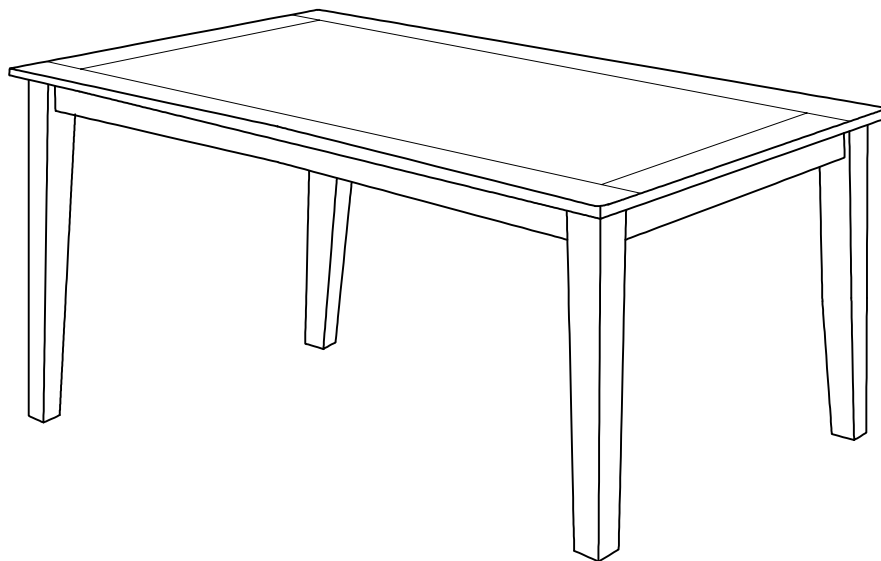

ASSEMBLY IS COMPLETED