

4

3

2

NOTES:

(N1) 1. FIT / FORM / FUNCTION SHALL FOLLOW PS-E.008.

BILL OF MATERIAL (CURRENT LEVEL)

ITEM	PT/ASSY	DESCRIPTION	TYPE	QTY.
1	20-287	GRAB BAR MOUNTING HARDWARE PACK	ASSEMBLY	2
2	5084	GRAB BAR AND ADAPTER ASSY	ASSEMBLY	1
3	40676	DECORATIVE RING	PART	2

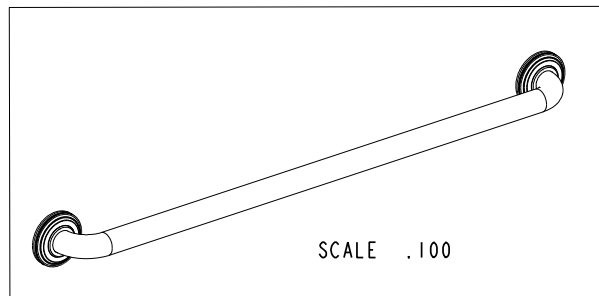
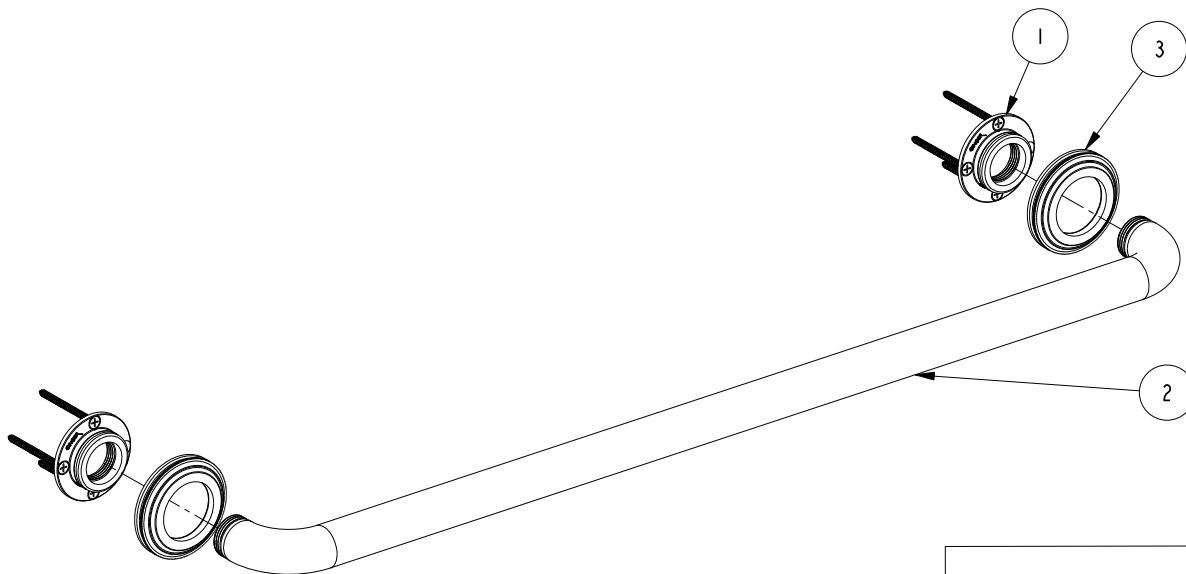

COPYRIGHT 2005 BRASSTECH, INC.  
 THESE DRAWINGS AND THE DESIGNS  
 DEPICTED HEREIN ARE THE PROPRIETARY  
 PROPERTY OF BRASSTECH. ANY USE  
 OR REPRODUCTION IS SUBJECT TO  
 THE EXPRESS APPROVAL OF BRASSTECH.  
 UNAUTHORIZED USE IS STRICTLY  
 PROHIBITED. ALL RIGHTS RESERVED.

ZONE	REV	DESCRIPTION	DATE	APPROVED
-	-	EN-3279b	07/13/17	J.M.

TESTING	-	-	-	-
ASSEMBLY	-	-	-	-
PLATING	-	-	-	-
POLISHING	-	NEXT ASSY	USED ON	-
MACHINING	-	APPLICATION		-
TOOLING	FIXTURE #	REMOVE ALL BURRS AND SHARP EDGES		-

UNITS ARE: INCHES [MM]	
TOLERANCES ARE:	
FRACTIONS	DECIMALS
±1/16"	±.005
.X ±.1 [2.5]	ANGLES ±1°
.XX ±.06 [1.5]	
(X.XXX) DENOTES CRITICAL DIMS.	
ALL THREADS ARE CRITICAL	
DRAWN	R.S. 07/13/17
CHECKED	J.M. 07/13/17
APPROVED	J.M. 07/13/17

**BRASSTECH** 2001 CARNEGIE AVE.  
 INCORPORATED SANTA ANA, CA 92705  
 (949) 417-5207

**32" CURVED GRAB BAR ASSEMBLY**

DWG NO. **1600-3932** REV -

SCALE .312 REF. - SHEET 1 OF 2

4

3

2

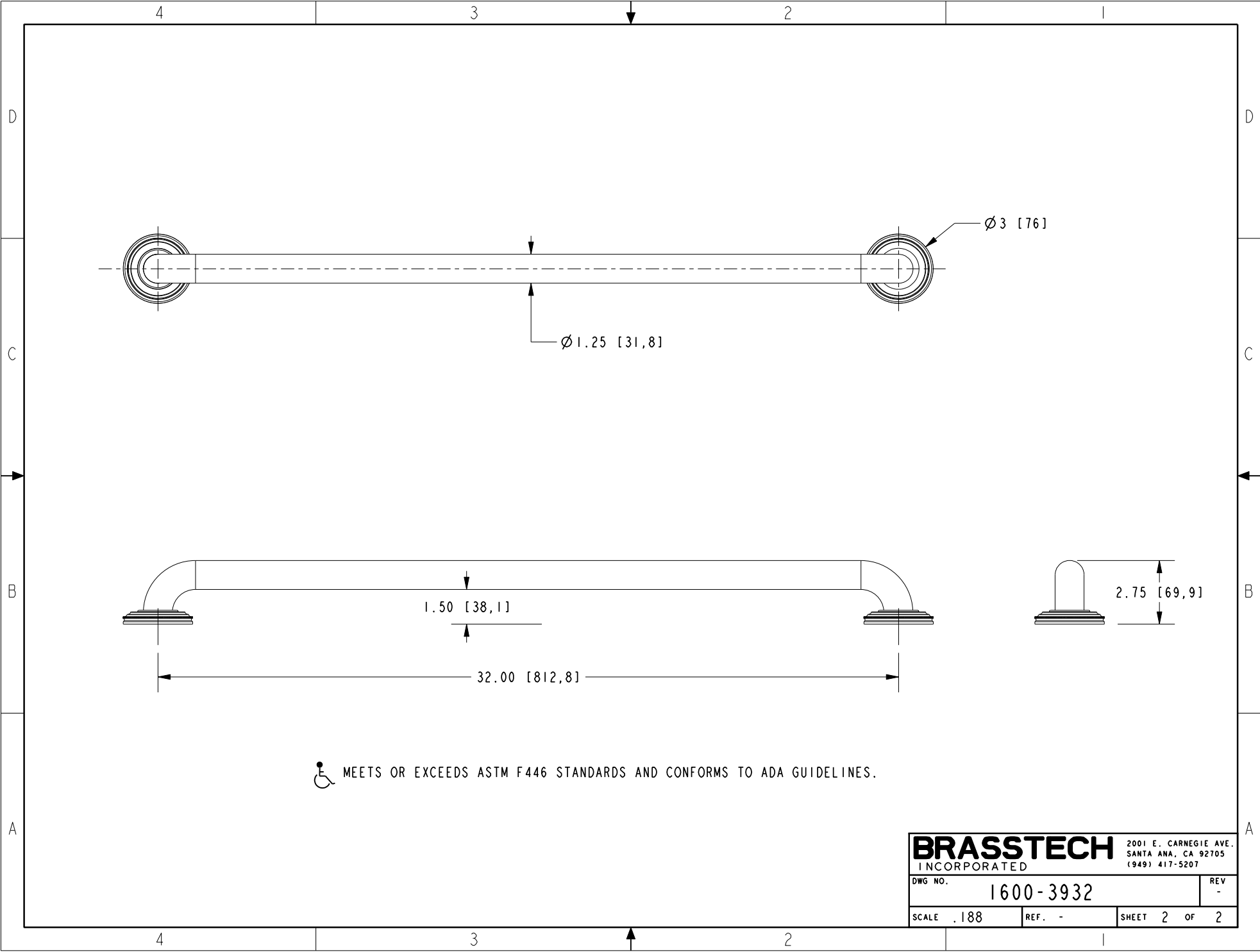

 MEETS OR EXCEEDS ASTM F446 STANDARDS AND CONFORMS TO ADA GUIDELINES.

<b>BRASSTECH</b>		2001 E. CARNEGIE AVE.	
INCORPORATED		SANTA ANA, CA 92705	
		(949) 417-5207	
DWG NO.	1600-3932	REV	-
SCALE	.188	REF.	-
		SHEET	2 OF 2