

TRAMPOLINE

WITH HANDLE

U S E R M A N U A L



MSG-1018A

Mini Trampoline with Handle



This manual only takes orange in all colors of the trampoline as an example, and all colors are installed in a common way.

Owner's Manual:



WARNING: ADULT ASSEMBLY Required.

Maximum weight on this trampoline should not exceed 55lbs or 25kgs

This Trampoline is made for children only. Read all instructions before using the trampoline. Warnings and instructions for the care, maintenance and use of the trampoline are included to promote safe enjoyable use of this equipment.

This Trampoline is suitable for children 1 year old plus.

Adult supervision required at all times.

A Child on the trampoline should never be left unattended while on the trampoline, we recommend full time supervision of the child while on the trampoline at all times.

IMPORTANT STATEMENT TO UNDERSTAND

We ask that you please read and totally understand the assembly and operation of this trampoline, before final assembly or beginning use of the trampoline. You will find important information enclosed related to this product for safety care and use we would like you to take the time to understand everything about this product. Please feel free to call upon us if you have any questions or concerns related to any aspects of this product we will be happy to assist you in making this assembly and purchase as smooth as possible.

ESSENTIAL INFORMATION

1. Misuse and abuse of this trampoline is dangerous and can cause injuries
2. All purchasers or persons assembling this trampoline must become familiar with the manufacturers recommendations for the proper assembly use care of this trampoline. If the assembler has any questions or misunderstanding of the assembly instructions he or she is highly recommended to contact our customer service department prior to continuing assembly of the trampoline
3. It is the RESPONSIBILITY of the owner of this trampoline to insure that one child at a time is on the trampoline, and that child is supervised and informed of all warnings and safety instructions.
4. ONLY Adult assembly required for this trampoline.

OPERATION USE

Handle must be held at all times when using the trampoline

1. Adequate overhead clearance at all times.
2. Always place the trampoline away from walls, structures, furniture, always maintain a clear space around the trampoline- we recommend at least 6 feet from the frame edge.
3. Always place the trampoline on a LEVEL SURFACE
4. Remove any obstructions from beneath the trampoline
5. Do not allow more than one child over the age of 3 on the trampoline at a time.
6. The Child should wear no obstructions while on the trampoline- (jewelry necklaces, earrings, any obstructions that can prevent free movement.
7. Never JUMP OFF the trampoline the child should always be instructed to step on and off the trampoline.
8. Never attempt any other functions or gymnastic functions or rough play on the trampoline this trampoline is design for young children ONLY. The only function on this trampoline should be a controlled bounce (exercise), for young children. No other functions should occur other than controlled bounce.
9. Use only in a well lit area.

CARE & MAINTENANCE

1. Always inspect the trampoline before each use and replace any worn defective, or missing parts.
2. Always check to make sure all screws are secure on the frame.
3. Periodically check stitching or fabric of the bed or frame padding for any deterioration.
4. For indoor & outdoor use- DO NOT leave outdoors when not in use.

TRAMPOLINE STORAGE

Once your trampoline is assembled we recommend that you don't take the frame apart, simply remove the 5 legs & handle for flat storage.

ASSEMBLY INSTRUCTIONS

Place contents from the box in a cleared area and position them on the floor in front of you. Do not dispose of the packing materials or the box until assembly is completed. Read each step carefully before beginning.

General Precaution Measures before and after assembly. Keep children away from the trampoline during assembly.

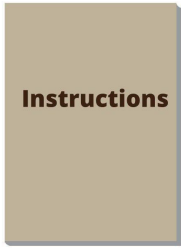

1 Instruction/1pc



2 Leg Tube/5pcs



3 Frame Tube3/2pcs



4 Frame Tube4/3pcs



5 Screw/7pcs

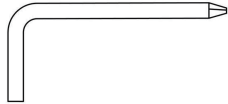

6 L Hex Wrench/1pc

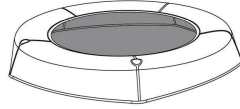

7 Pad & Mat/1pc



8 Bungee Cord /20pcs

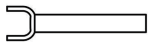

9 Tool/1pc



10 Handle Tube/2pcs

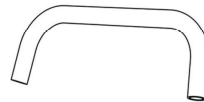

11 U-shaped Handrail Tube /1pc

Trouble Shooting:

If you should find that once assembled, the trampoline is not level on the ground, continue to Adjust the mat so that there is equal tension on all sides of the frame.

If you can't contact the seller in case of any problems, please contact the trampoline factory through this email address and we will provide you with assistance: service@cnmersco.com

INSTRUCTION

Step 1:
Insert the Leg tube(#2) into the Frame tube(#3) and secure it with screws(#5). Note that the screws are installed from the inside!!

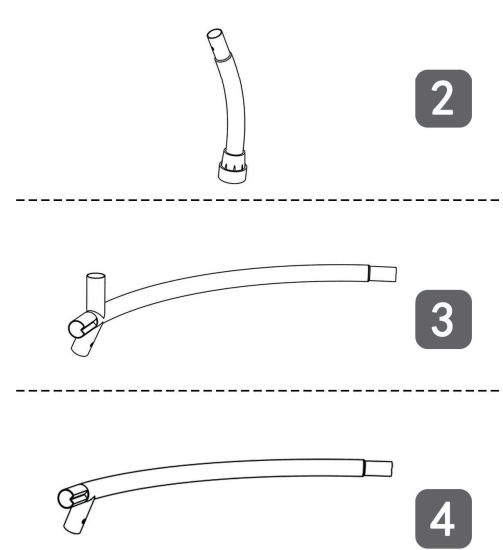

Step 2:
Connect the other Frame tubes(#4) in sequence to form a circle as shown in the figure below.
Tip: Push the frame inward as far as possible to prevent the Frame tube from falling off.

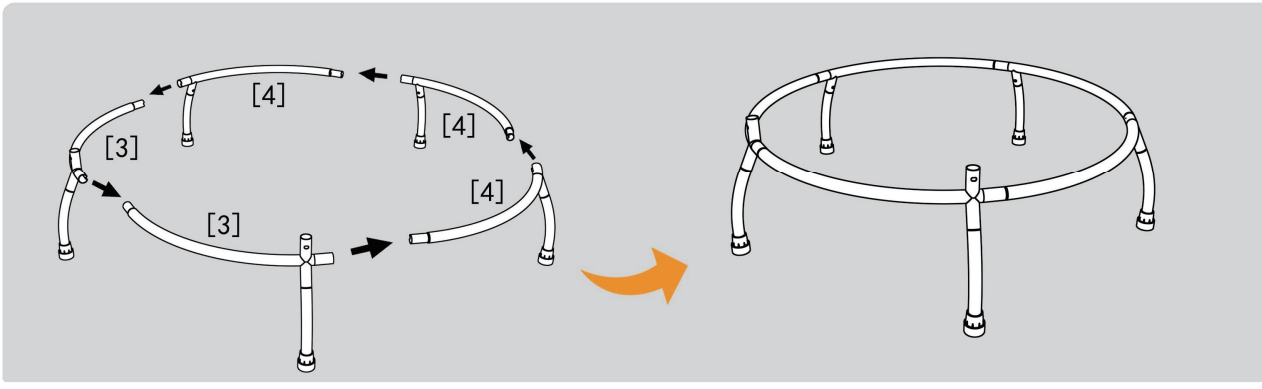
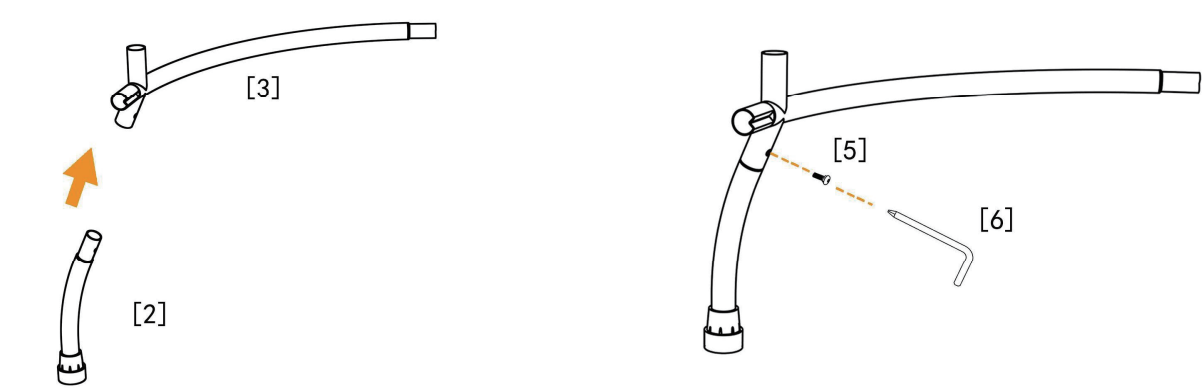

Step 3:

First, insert the bungee cord(#8) into the jumping mat in the same direction. Then put the cover(#7) on the frame. Fix the bungee cord(#8) on the frame with tool(#9), as shown in the figure below.

Tip:When installing the bungee cord, install it as symmetrically as possible. There are four bungee cord on each frame tube.

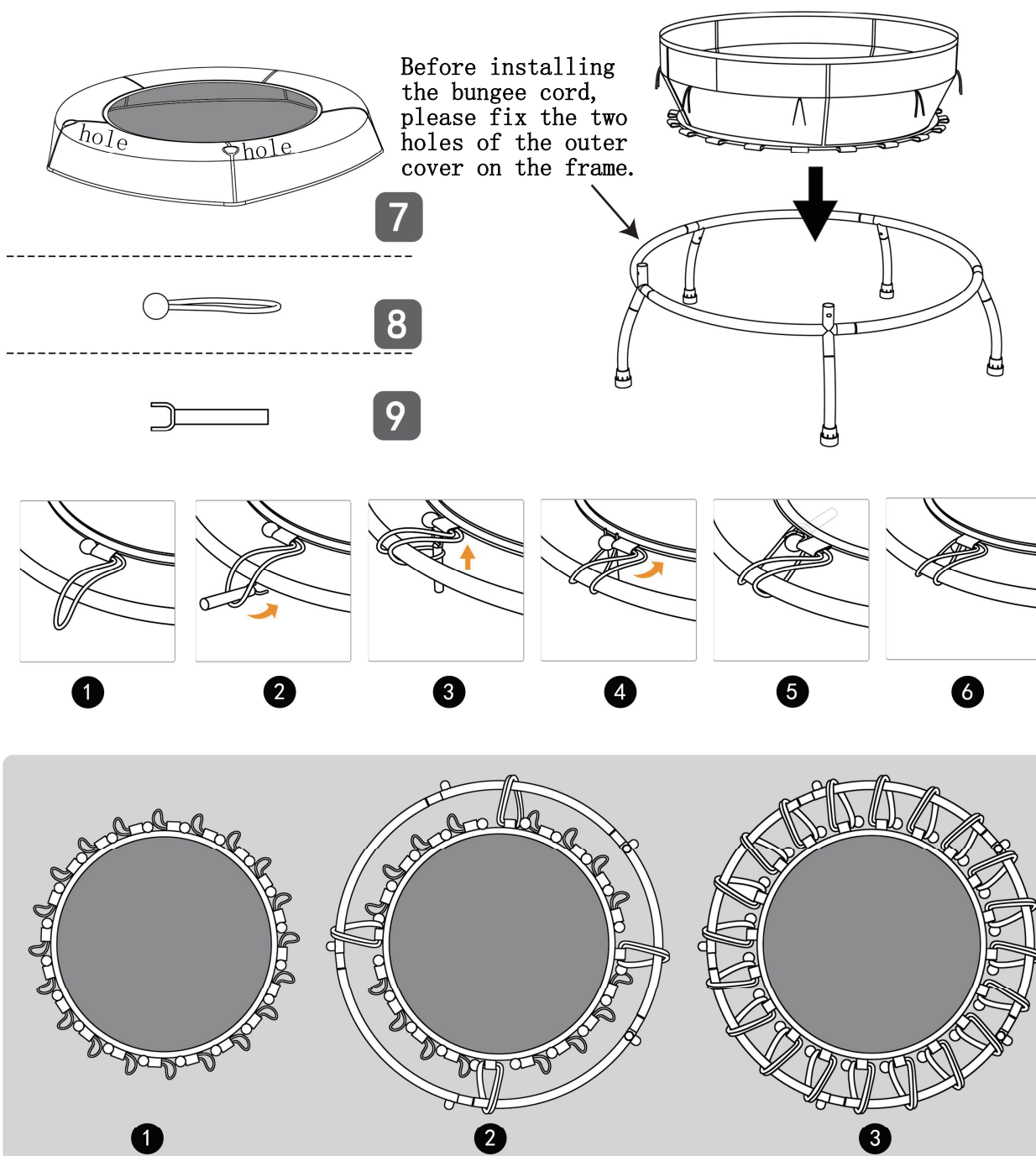

Step 4:

Tie the webbing from the cover to the frame.

Tip: You can tie it as tight as possible to prevent the cover from moving during jumping.

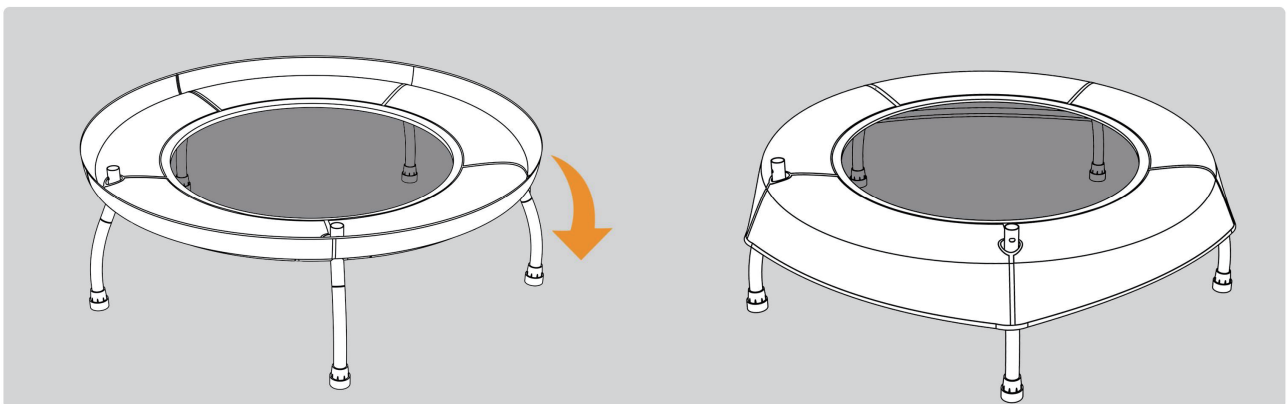
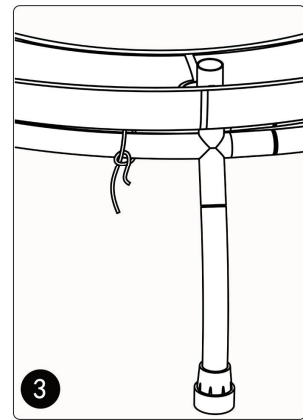
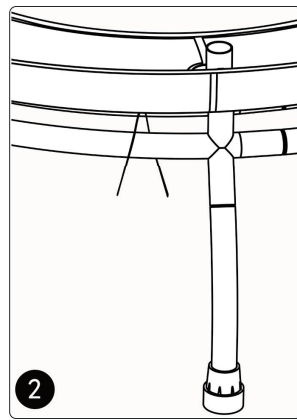
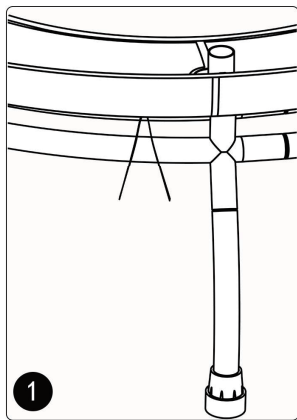
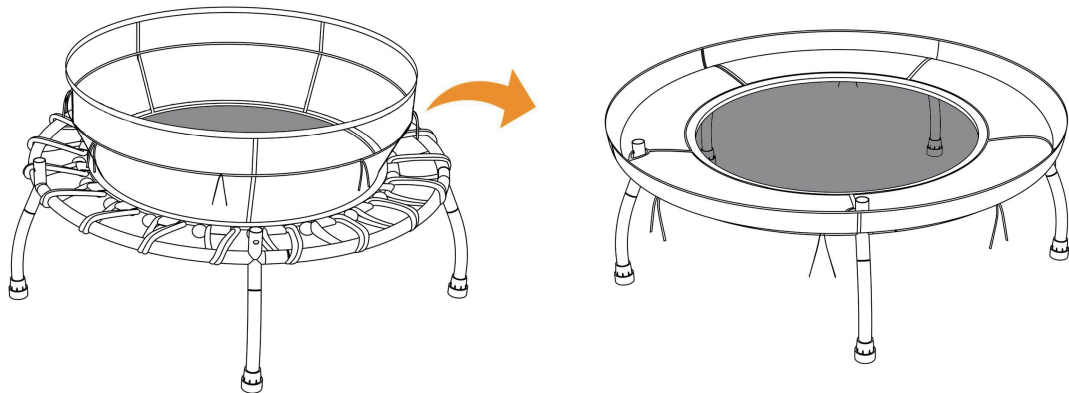

Step 5:

Insert the handle tube(#10) into the frame and secure it with screw(#5)
(Please distinguish left and right directions).

Then insert the U-shaped handrail tube(#11) into the handle tube(#10).

