

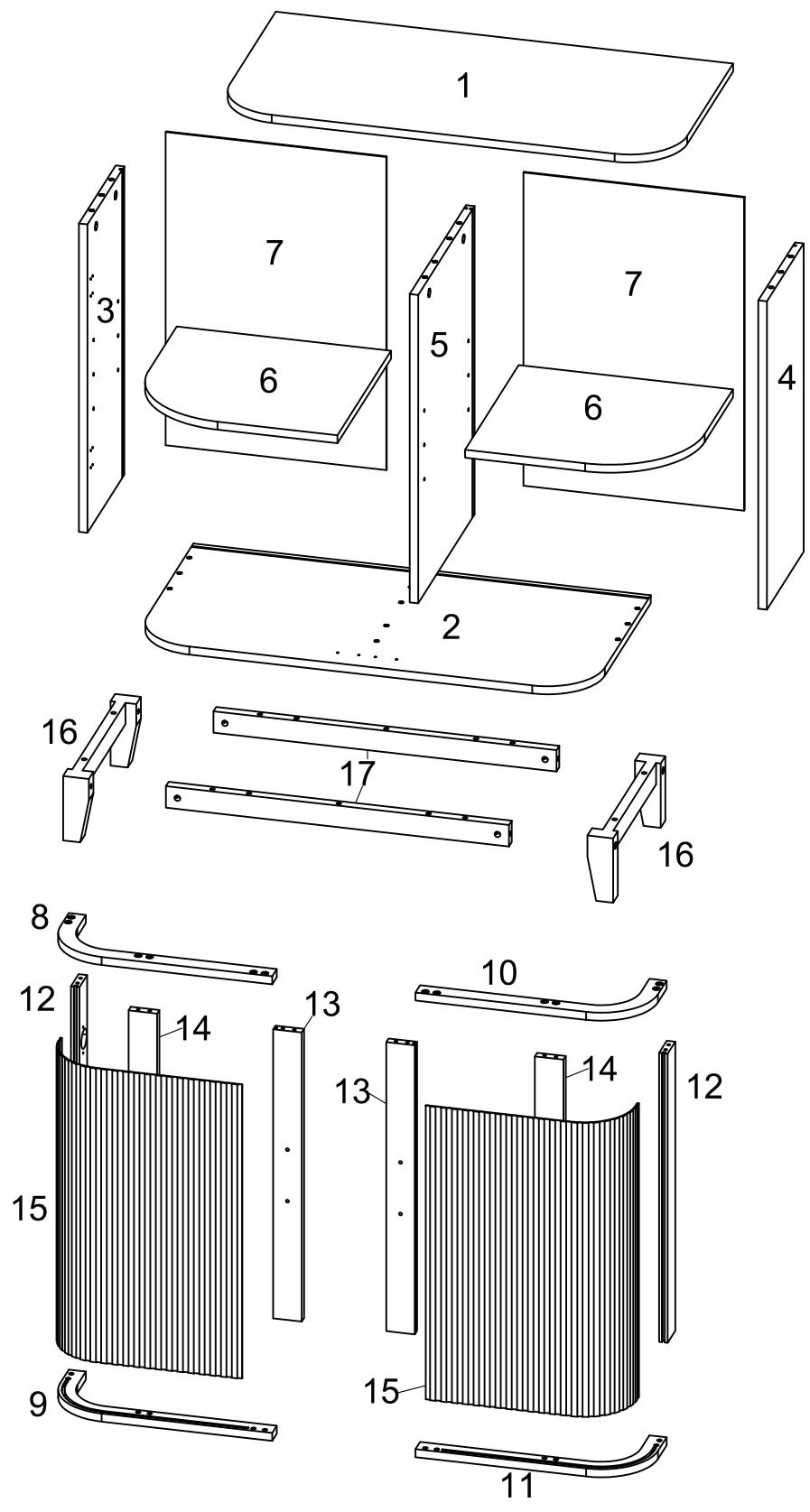









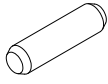
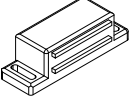

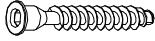



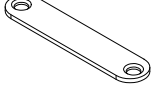
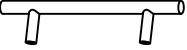

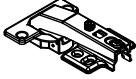

EXPLODED DRAWING





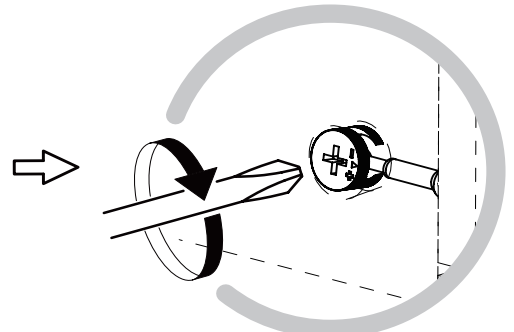
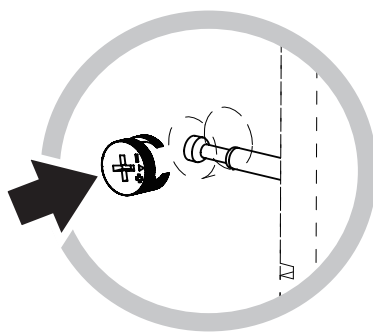
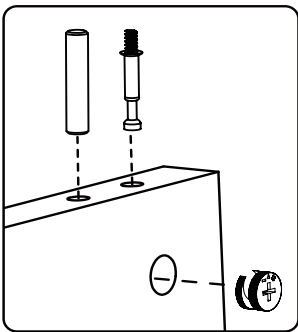

PARTS

	A × 6		B × 6 M15 × 12		C × 12 M8 × 30		D × 2
	E × 4 M3 × 16		F × 4 M10 × 12		G × 6 M7 × 50		H × 8
	J × 4 M3 × 12		K × 4 M6 × 55		L × 10 M6 × 35		M × 2
	N × 2		P × 4 M4 × 22		Q × 4		R × 8
	S × 4 25 × 25 × 3		T × 32 M3.5 × 14		U × 6 M20	    V × 2 M13 M4 × 12 M4 × 35	
	W × 1 M4		X × 24 M5 × 50				

MINIFIX POSITION

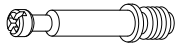

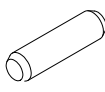
1

	A × 6 M6×35		D × 2
	C × 4 M8×30		E × 4 M3×16

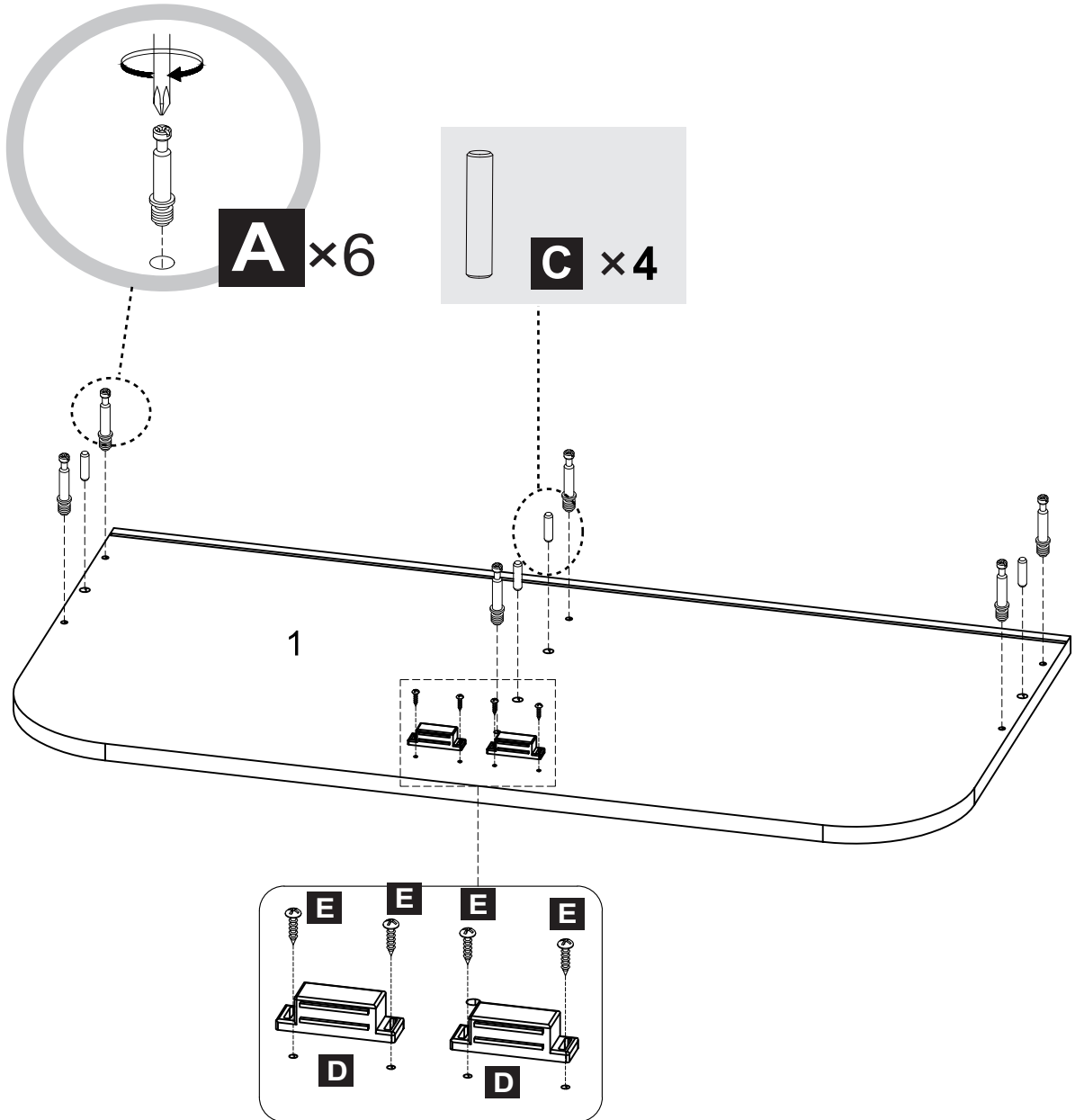

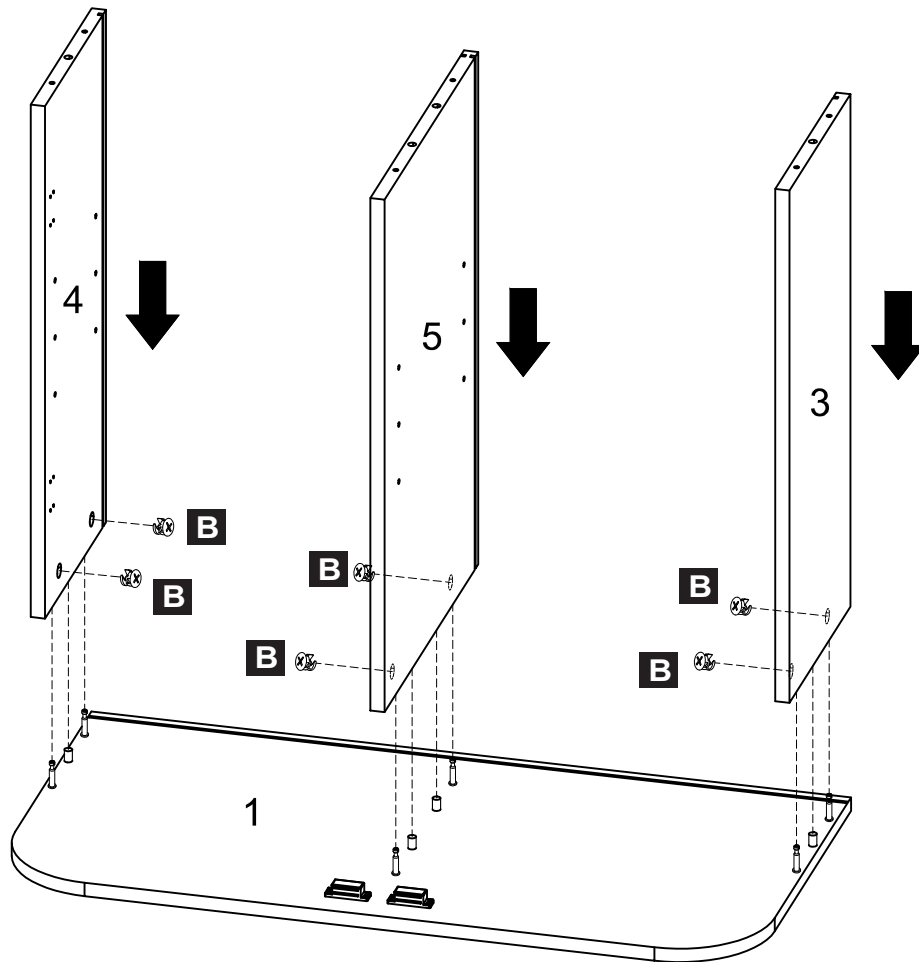
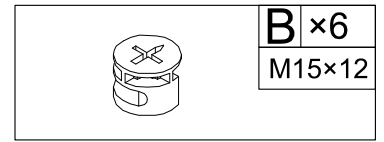

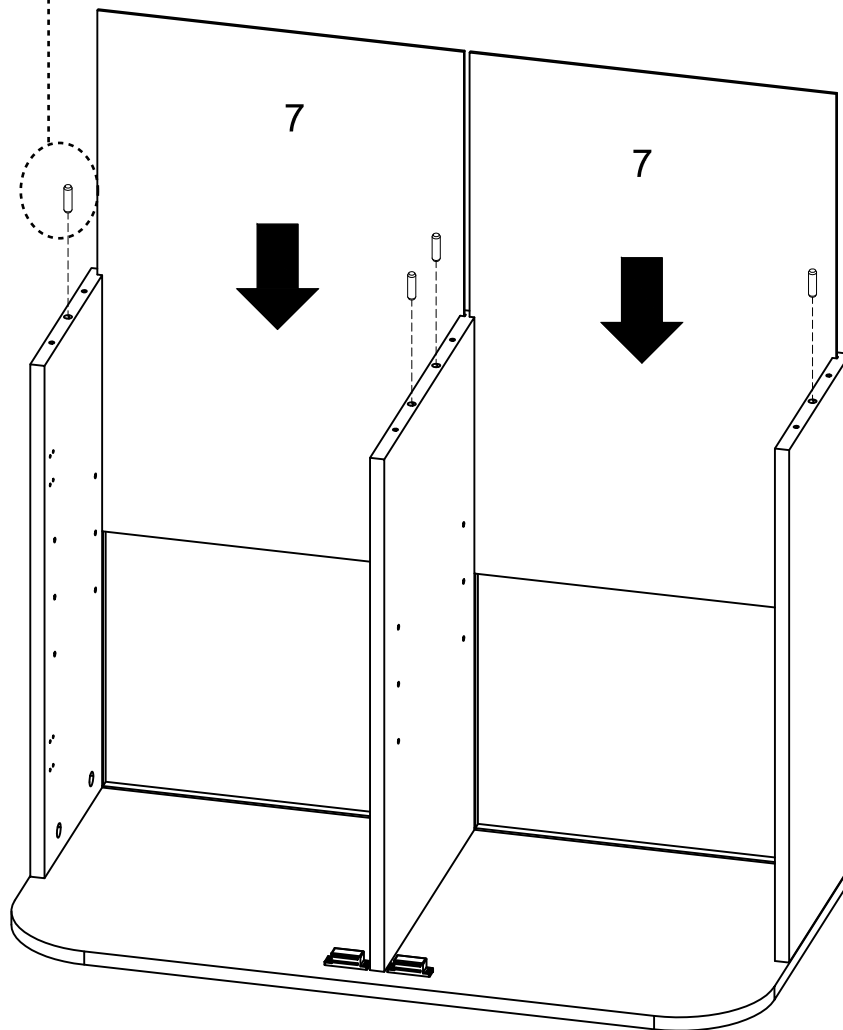
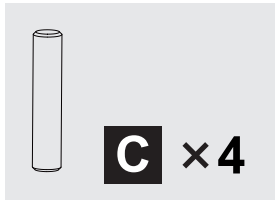
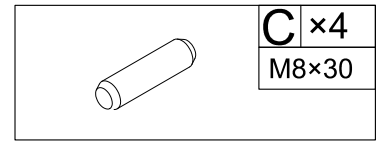

3

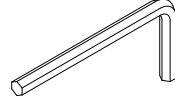

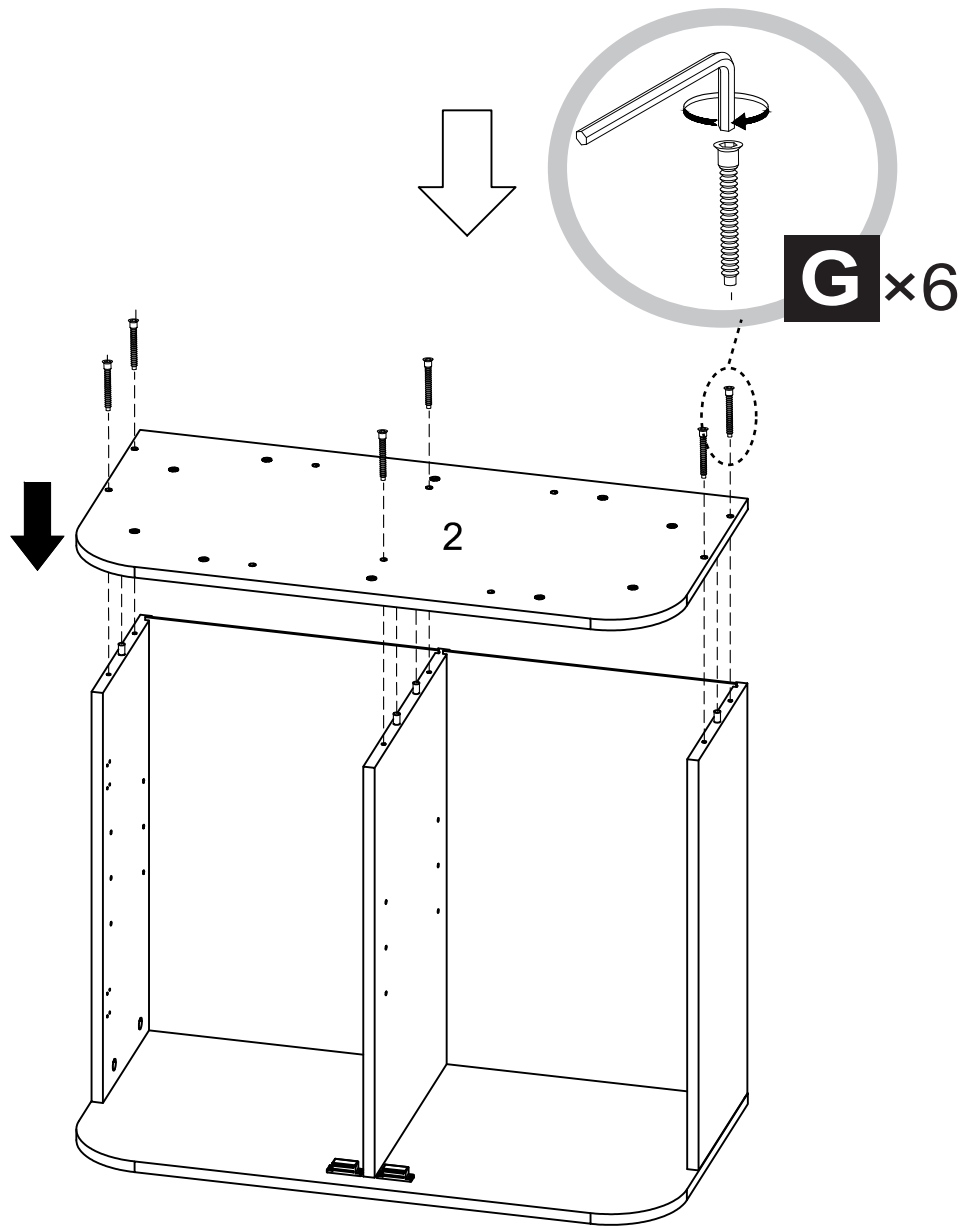
	G ×6
	M7×50
	W ×1

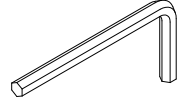

	F x4 M10x12		K x4 M6x55
			

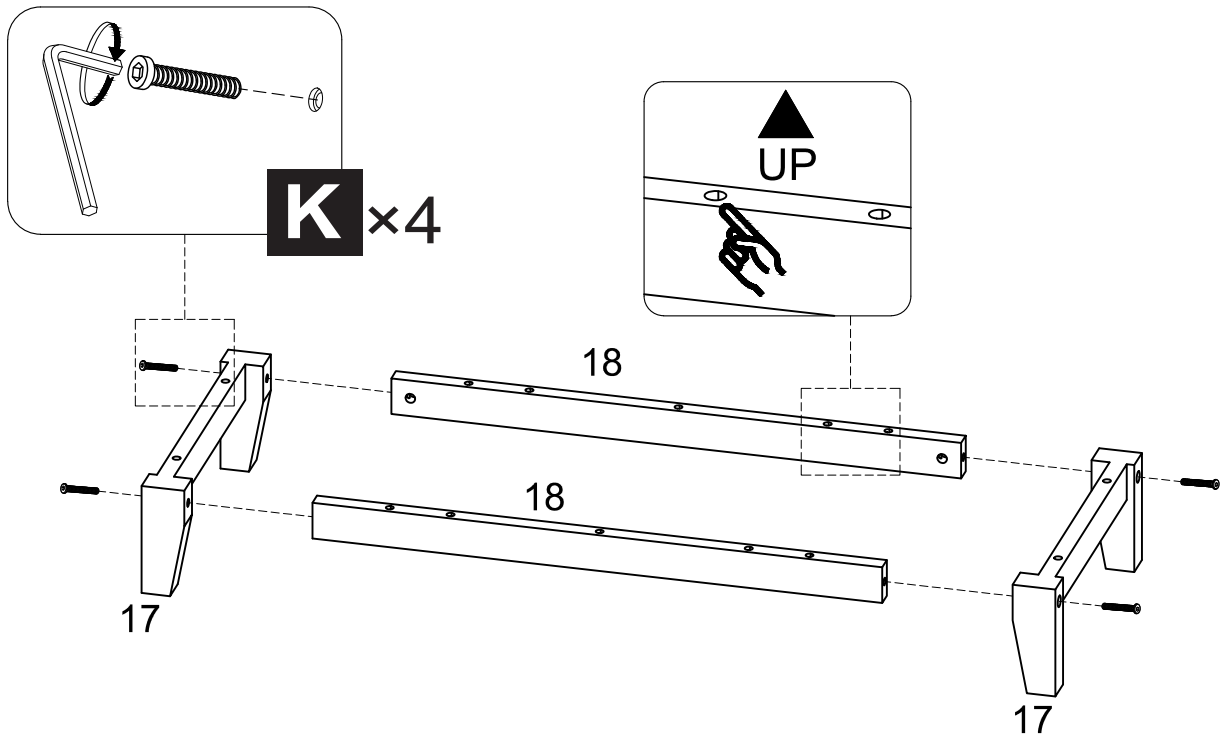
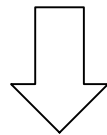
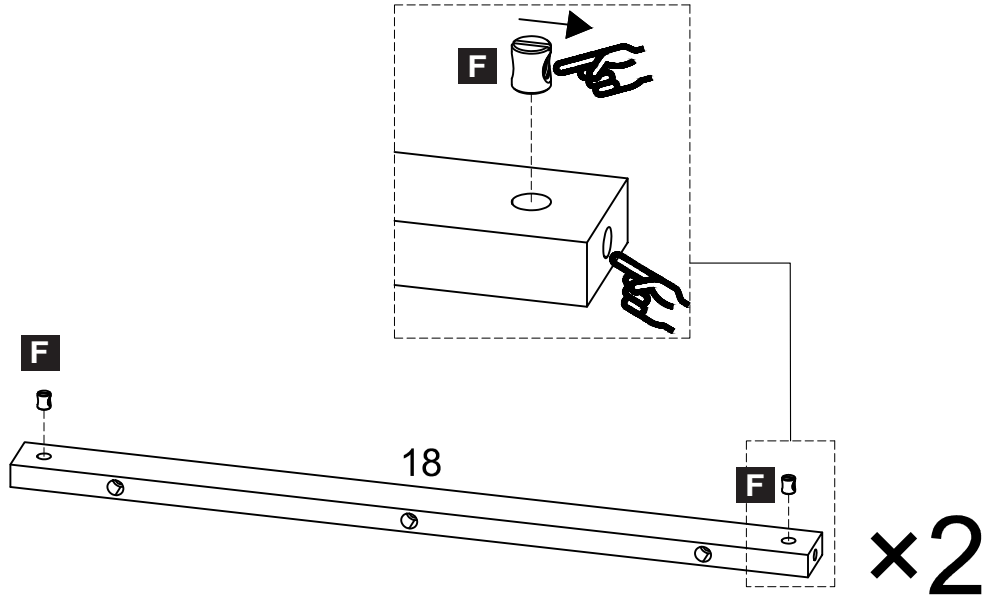

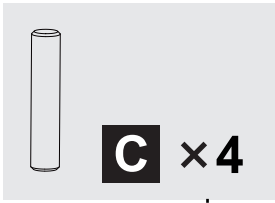

6

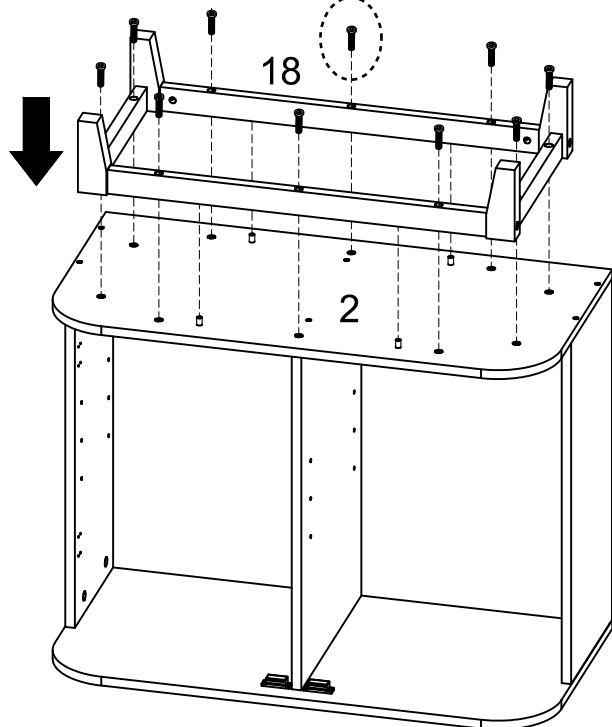
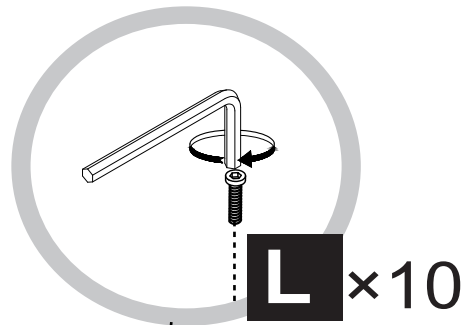
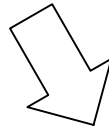
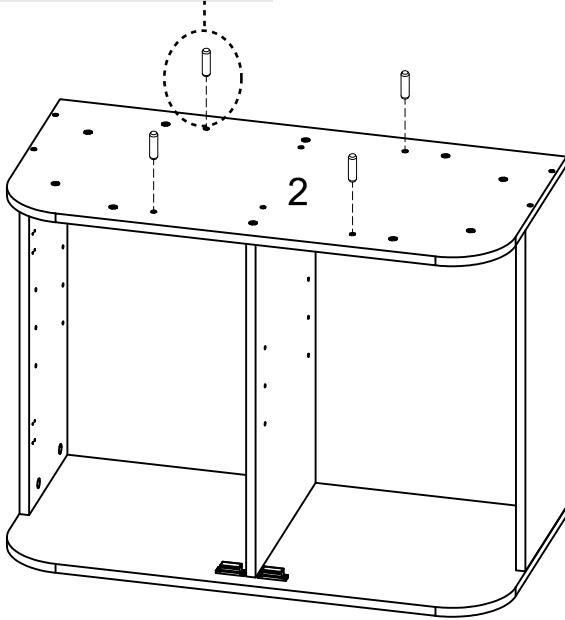

	C × 4 M8×30		L × 10 M6×35
			W × 1



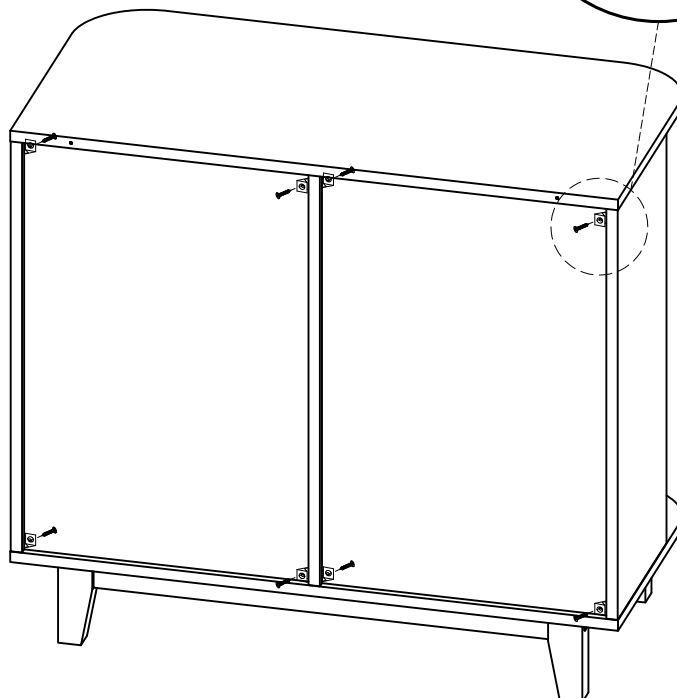
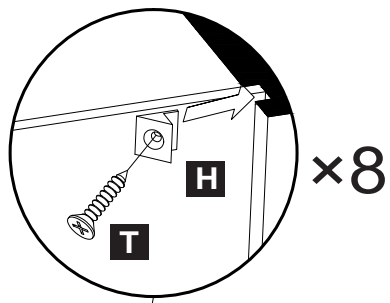
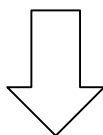
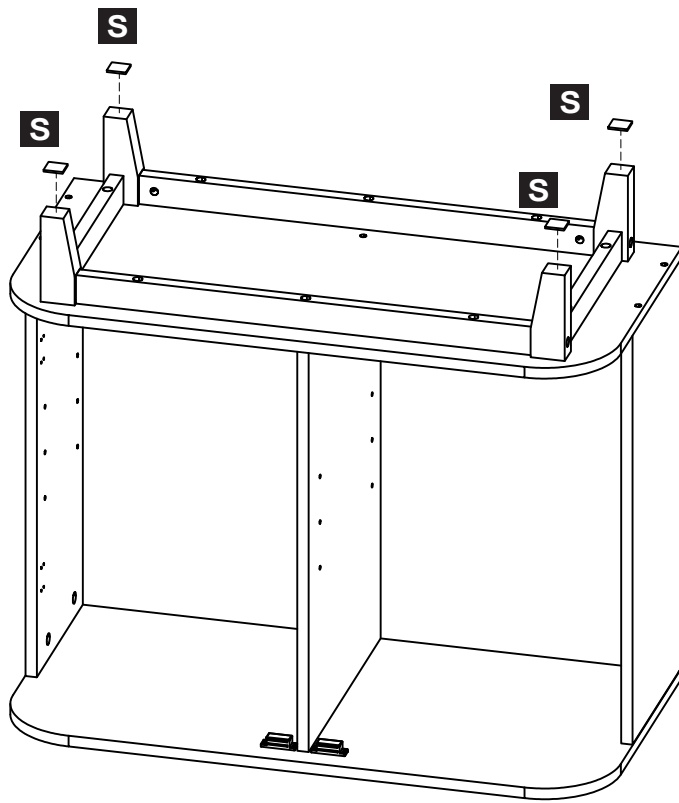

	S × 4 25×25×3		H × 8
			T × 8 M3.5×14

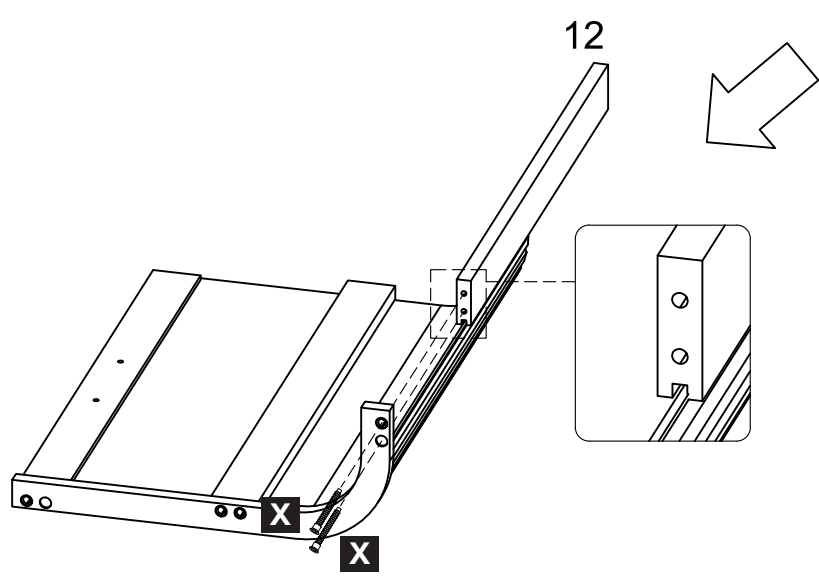
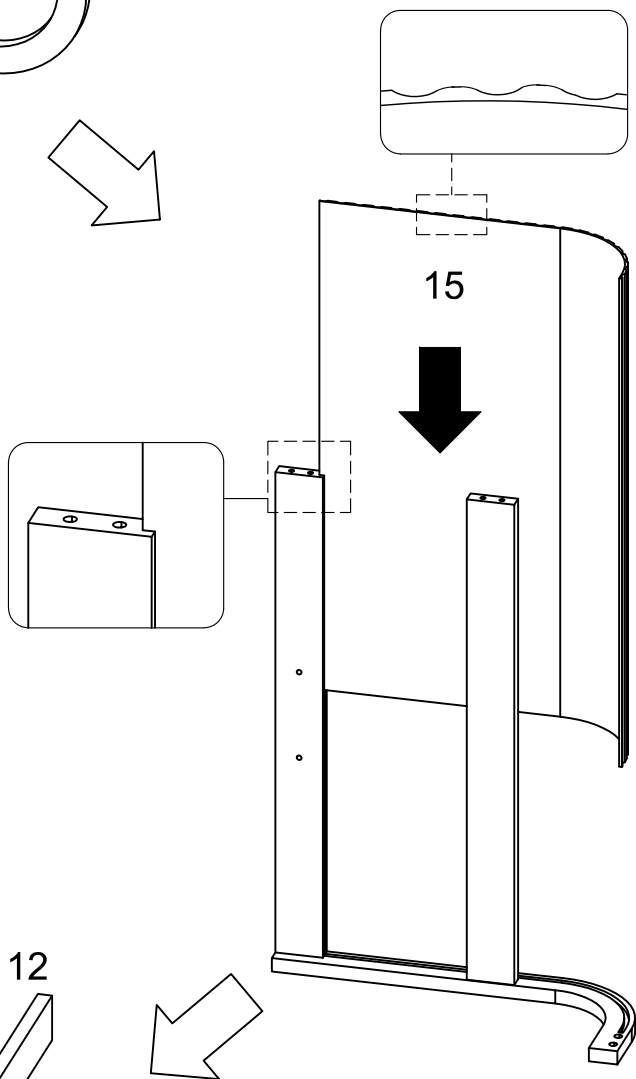
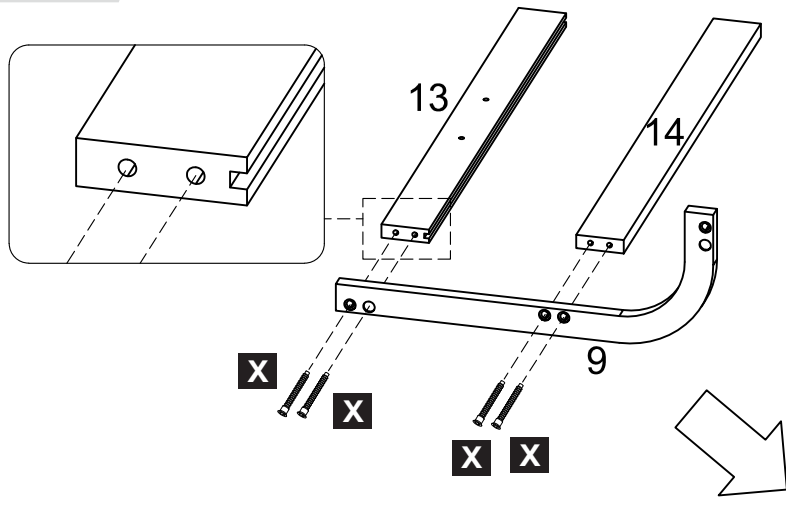
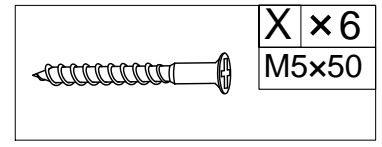

8

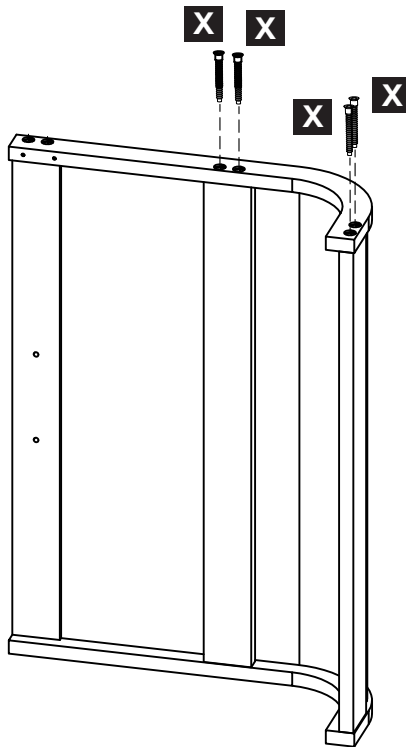
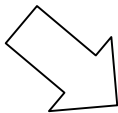
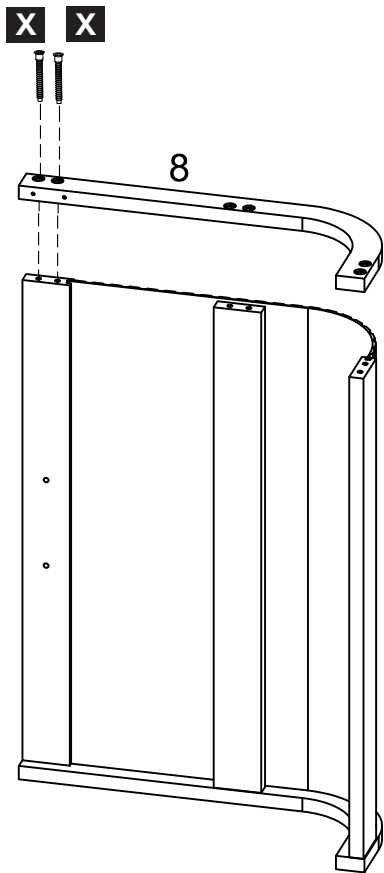
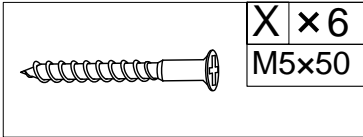

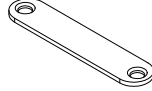
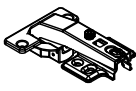
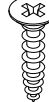

	J ×2 M3×12		M ×1
	Q ×2		T ×4 Ø3.5×14

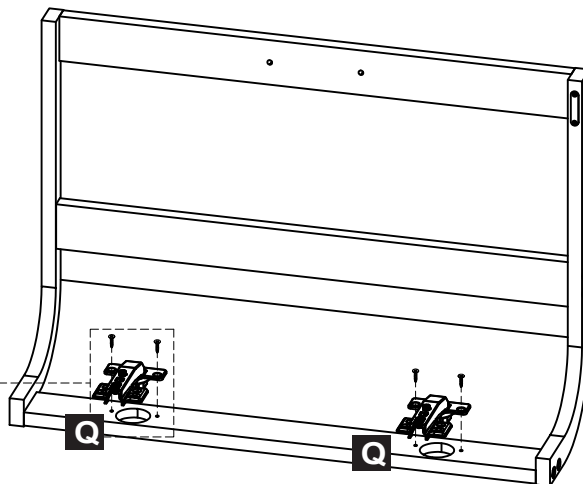
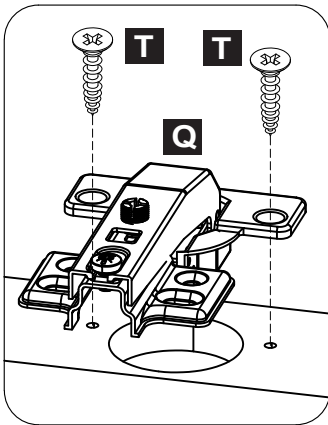
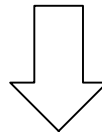
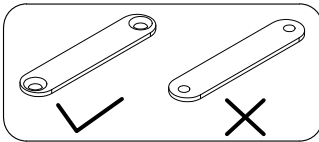
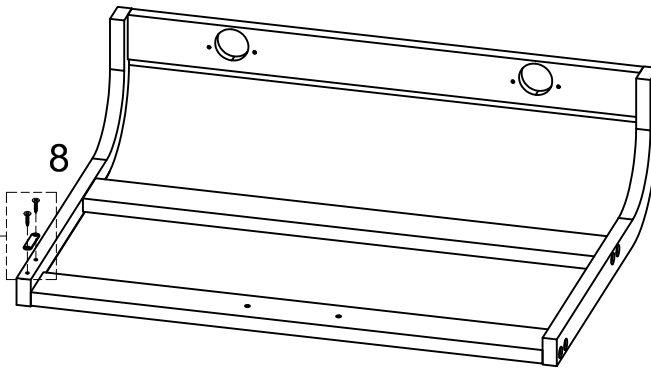
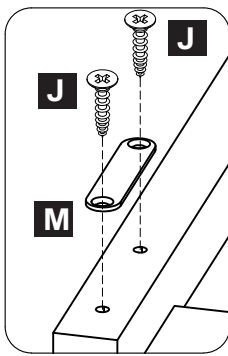

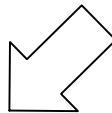
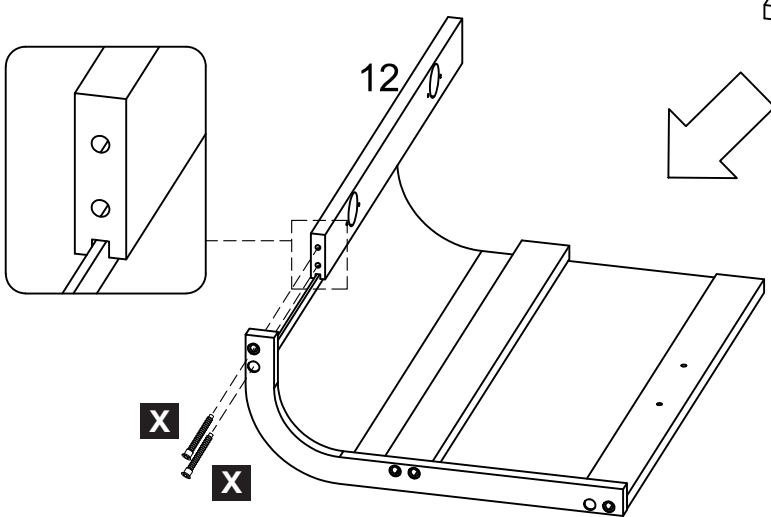
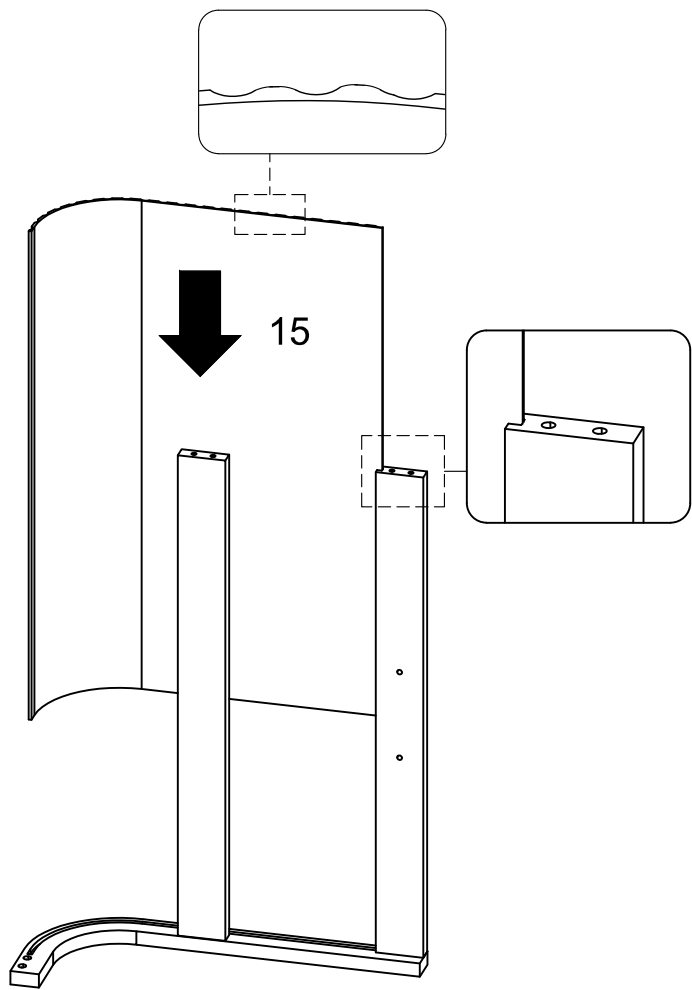
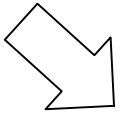
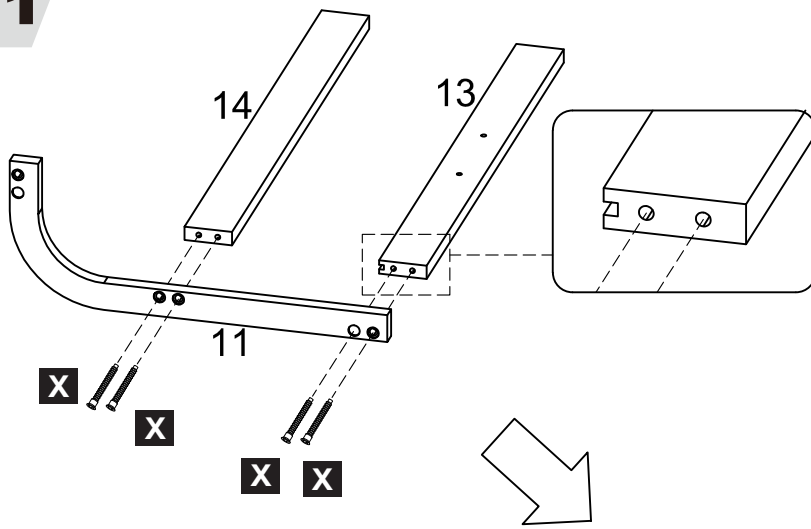
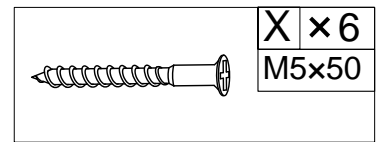

11

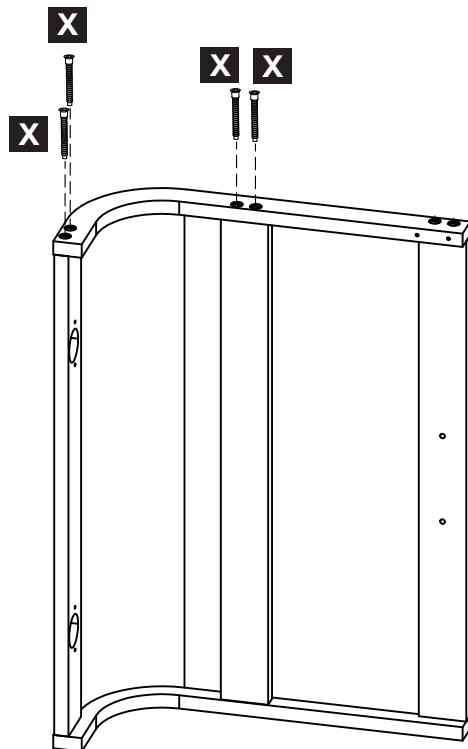
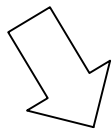
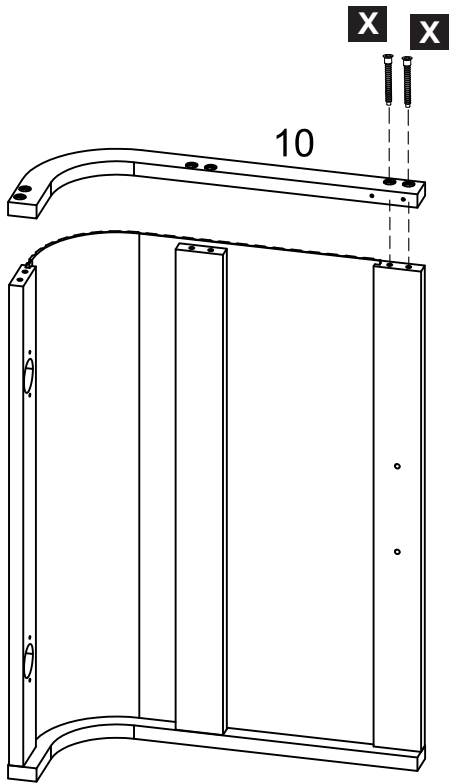
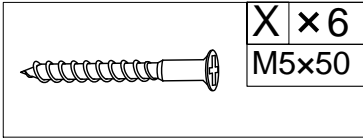

13

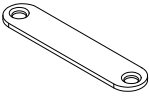

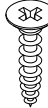
	J ×2 M3×12		M ×1
	Q ×2		T ×4 Ø3.5×14

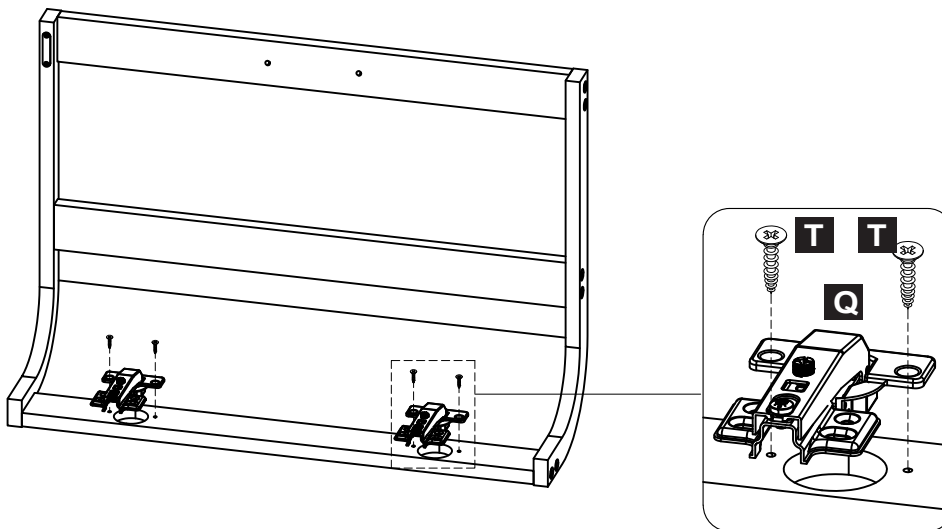
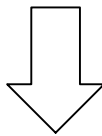
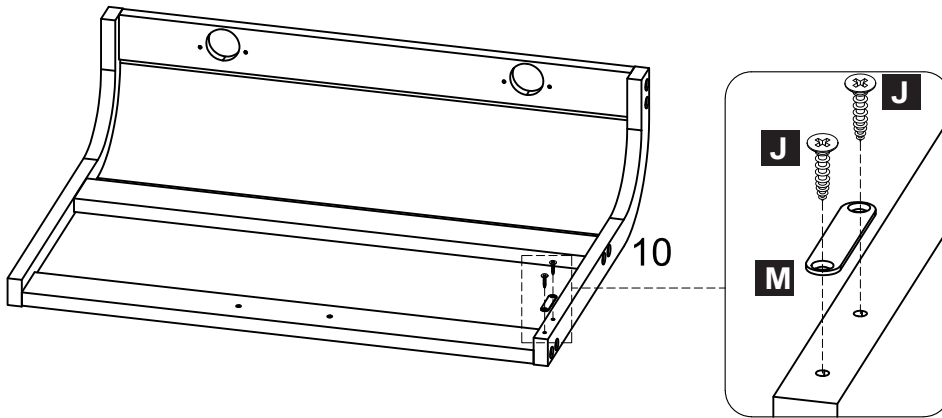

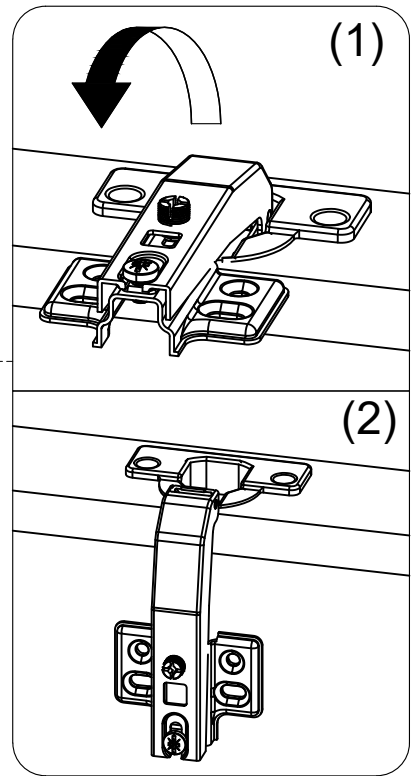
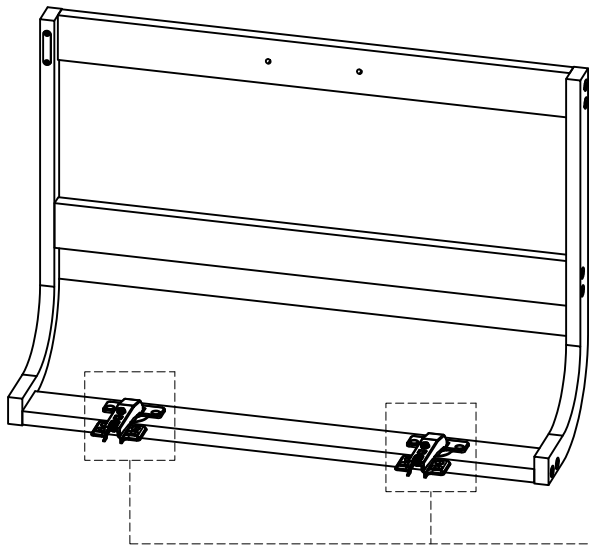
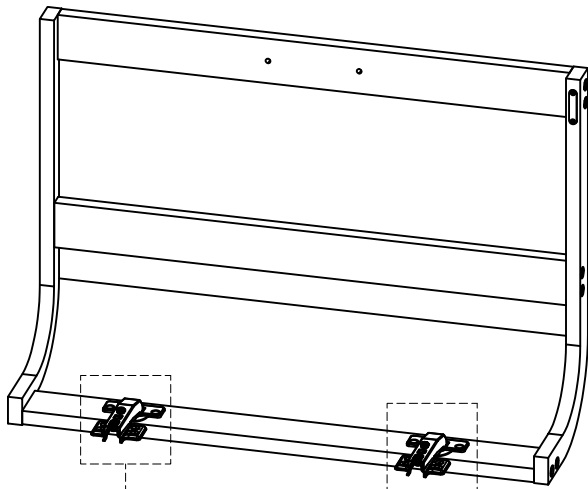

YOU WILL USE THIS PAGE FOR THE NEXT STEP

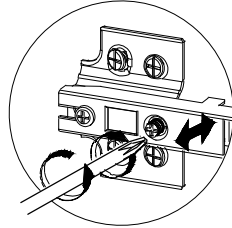
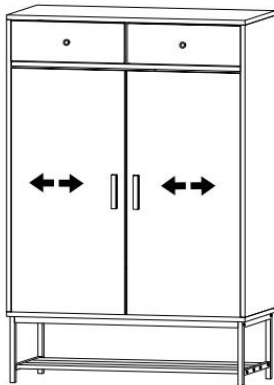
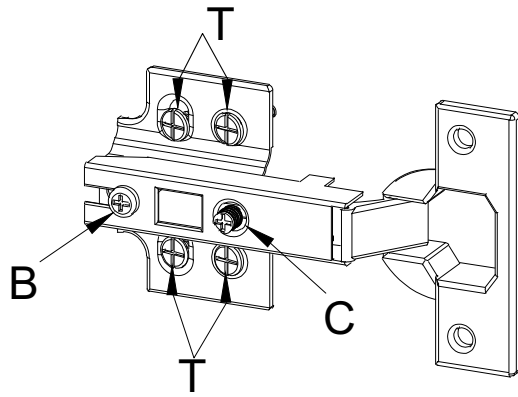

If you find a large gap between or beside the door

To adjust side ways.

Turning the screw "C" on BOTH hinges on each door.

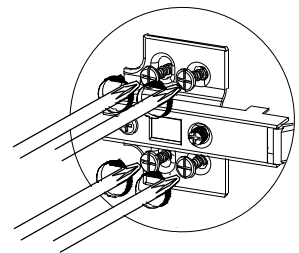
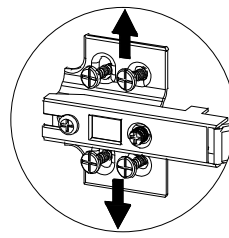
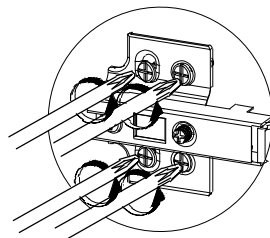
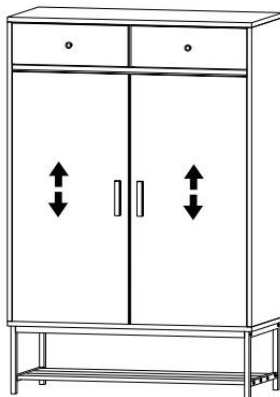

If you find a large gap above or below the door

To adjust the vertical height.

Loosen the four screws "T" on both hinges. Two of them are usually in slotted holes which allows you to adjust up or down by a few mm. Then tighten back up.

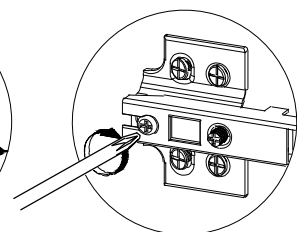
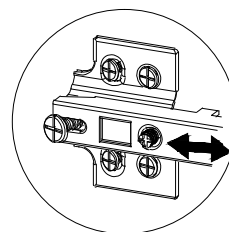
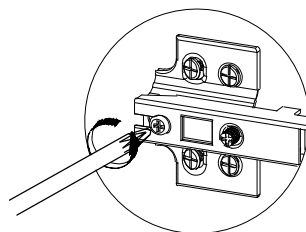
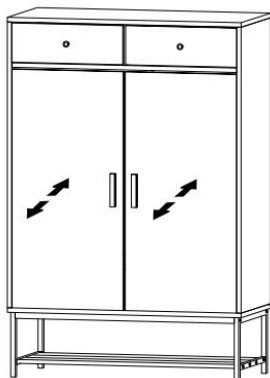

If you find the door is too protruding or too inside.



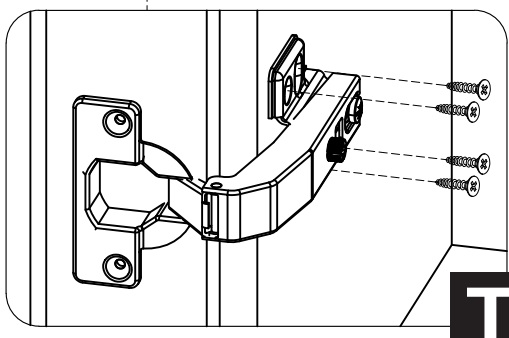
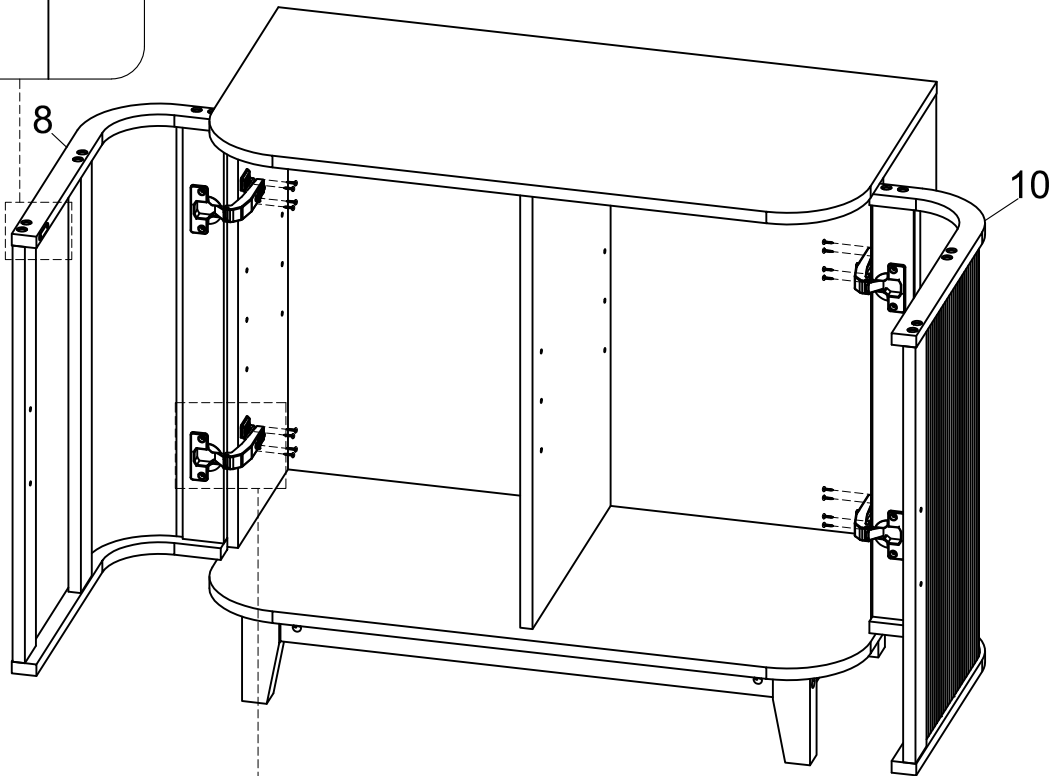
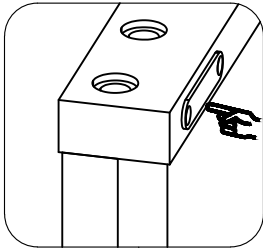
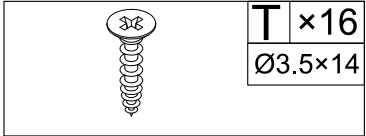

To adjust depth.

Loosen screw "B" and adjust door, if the door can not be adjusted, please loosen screw "C", then try again. Tighten screw "B" and "C".

15

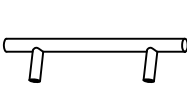

T × 4

	N x2		P x4 M4x22
	R x8		U x6 M20

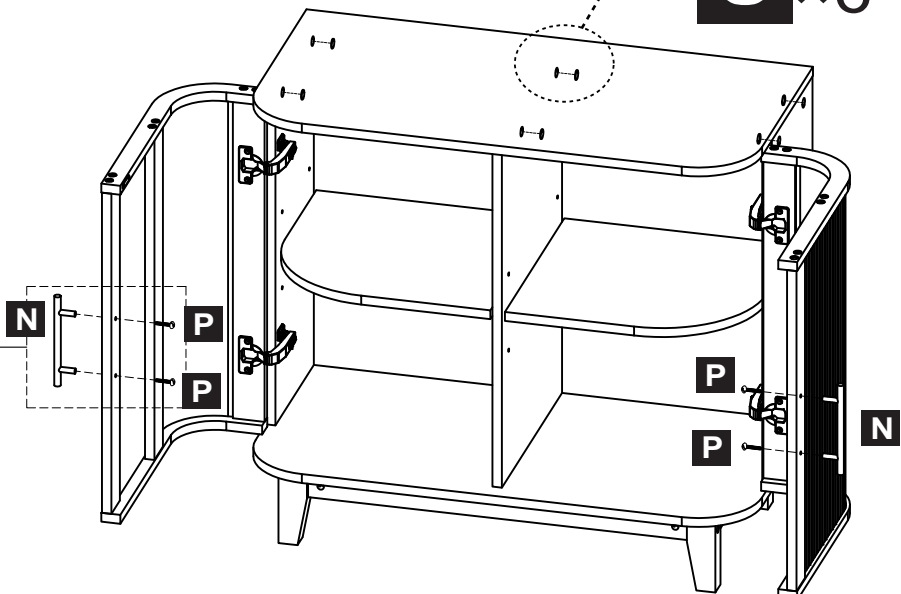
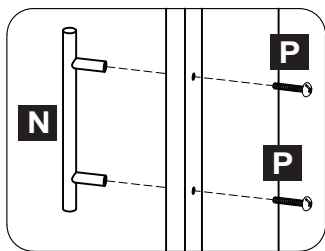
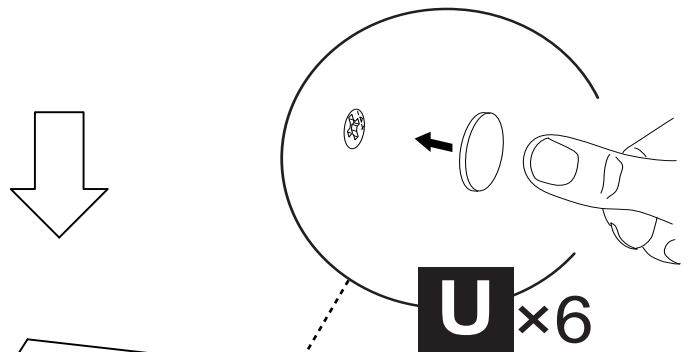
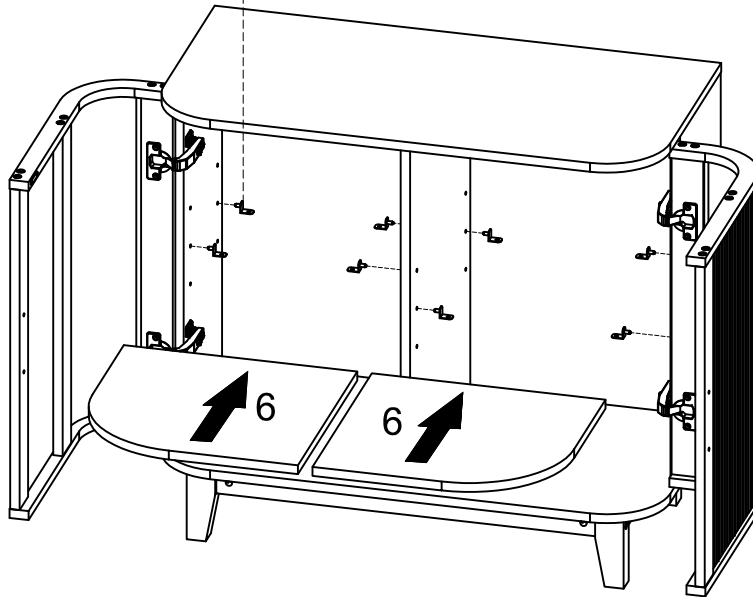
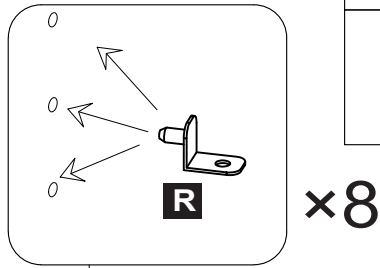

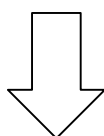
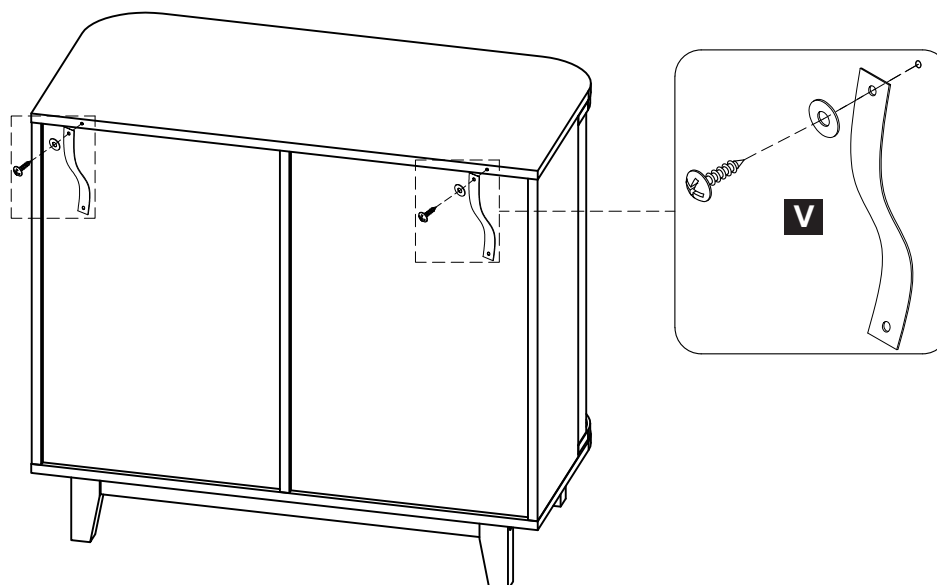
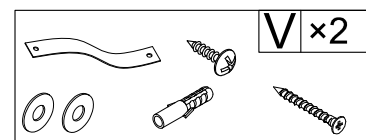

- (1) **WALL**
- (2) **WALL**
drilling hole
Ø6x30mm
- (3) **WALL**
V
- (4) **V**

