

# Carton Content

WF310632:







<b>A</b>	<b>TOP PANEL</b>		1pcs
<b>B</b>	<b>LFAF</b>		2pcs
<b>E</b>	<b>SIDE STRETCHER</b>		2pcs
<b>F</b>	<b>MIDDLE STRETCHER</b>		1pcs





table hardware

WF310633:

<b>A</b>	<b>BACK FRAME</b>		4 pcs
<b>B</b>	<b>SEAT FRAME</b>		4 pcs
<b>C</b>	<b>FRONT LEGS</b>		8 pcs

chair hardware

WF310634:

<b>A</b>	<b>SEAT FRAME</b>		1pcs
<b>B</b>	<b>LEGS</b>		4pcs
<b>C</b>	<b>Table Legs(left)</b>		2pcs
<b>D</b>	<b>Table Legs(right)</b>		2pcs

bench hardware

# ASSEMBLY INSTRUCCIONES

ITEM NOTE : WF310632

## DINING TABLE

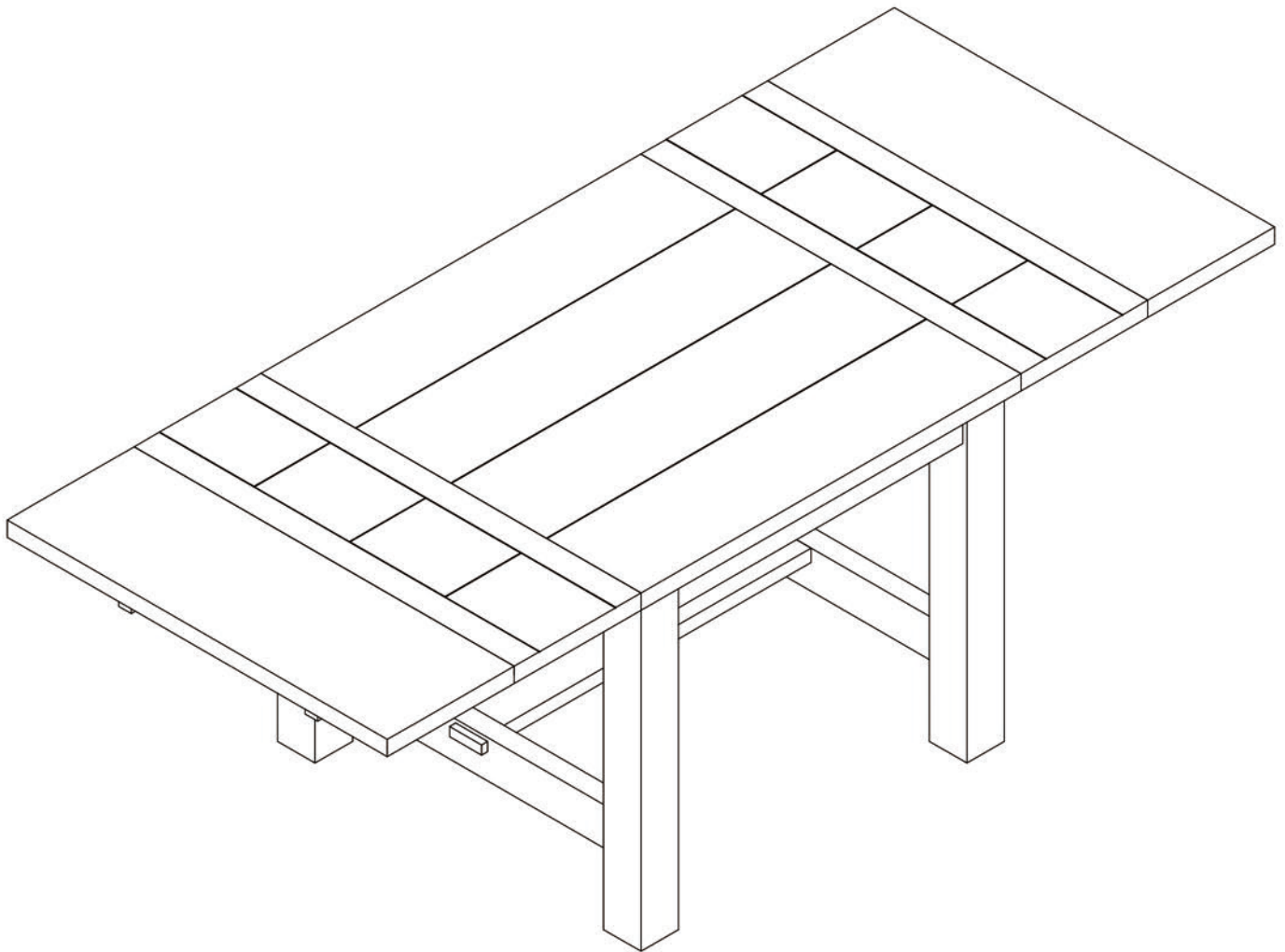





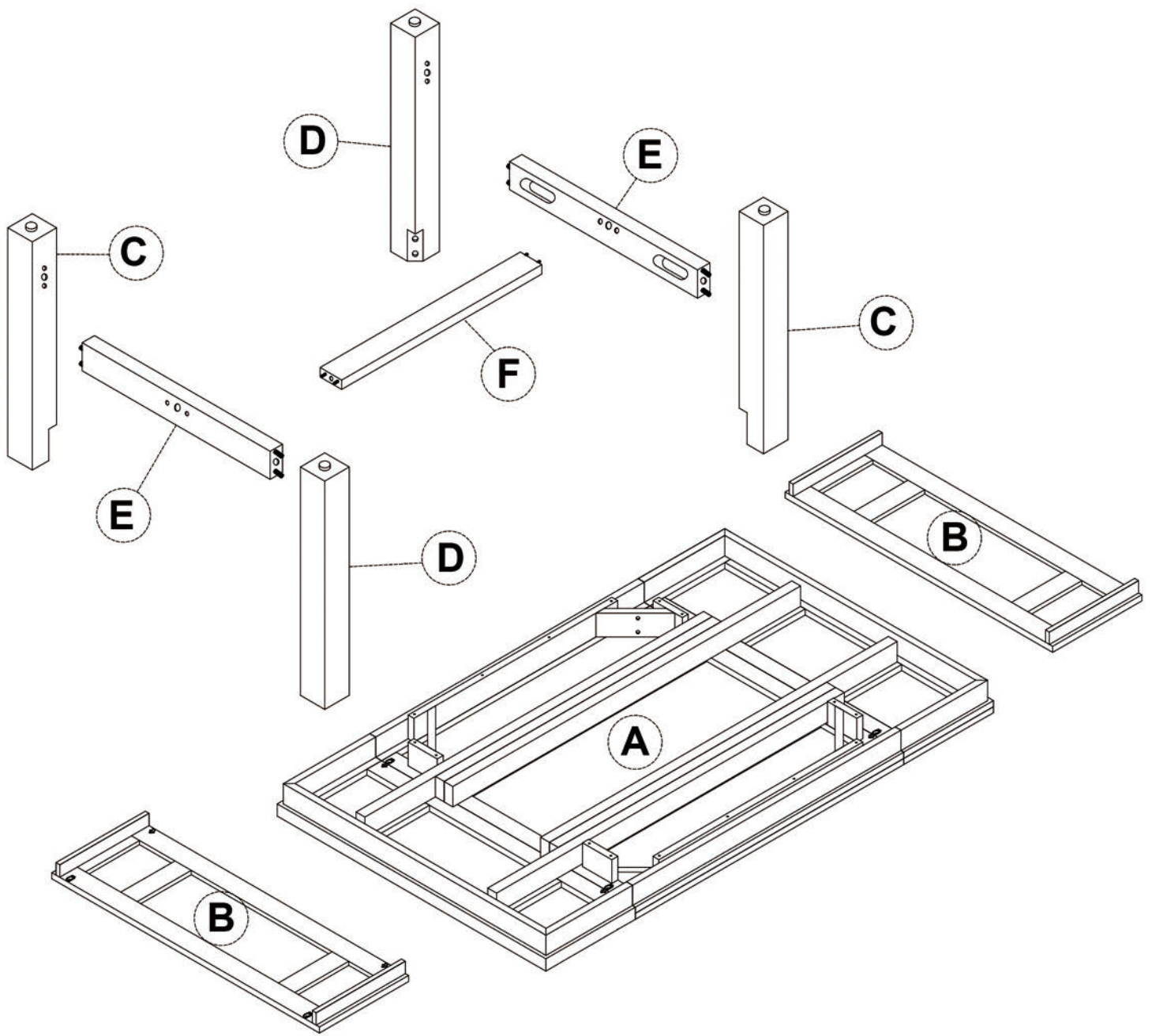



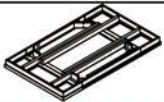

### IMPORTANT NOTE:

- ① PLACE ALL PARTS ON A CLEAN AND SMOOTH SURFACE SUCH AS A RUG OR CARPET TO AVOID THE PARTS FROM BEING SCRATCHED.
- ② BEFORE YOU BEGIN, KINDLY FOLLOW THE ASSEMBLY INSTRUCTIONS STEP BY STEP.
- ③ DO NOT TIGHTEN ALL SCREWS AND BOLTS UNTIL THE TABLE IS FULLY SET-UP





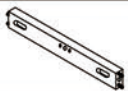

### Part List For One

### Hardware List For One

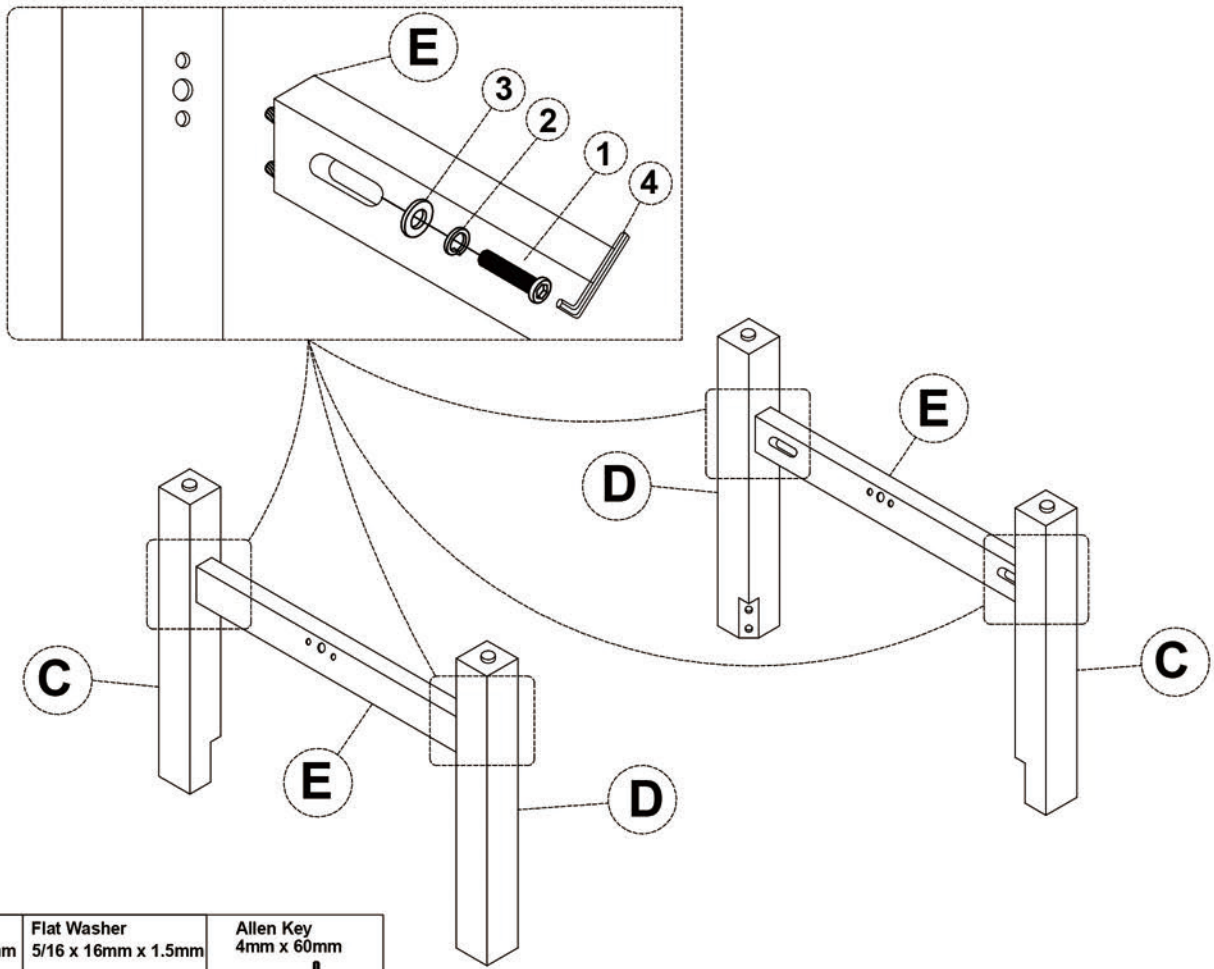
No	Parts Desc.	Q'ty	No	Hardware Desc.	Q'ty
A	TOP PANEL 	1pcs	1	Bolts 5/16"* 60mm 	14pcs
B	LFAF 	2pcs	2	Spring Washer 5/16"* 13mm x 1.5mm 	14pcs
C	LEGS (LEFT) 	2pcs	3	Flat Washer 5/16"* 16mm x 1.5mm 	14pcs
D	LEGS (RIGHT) 	2pcs	4	Allen Key 4mm*60mm 	1pcs
E	SIDE STRETCHER 	2pcs	5	Ornament 	2pcs
F	MIDDLE STRETCHER 	1pcs			





# STEP 1

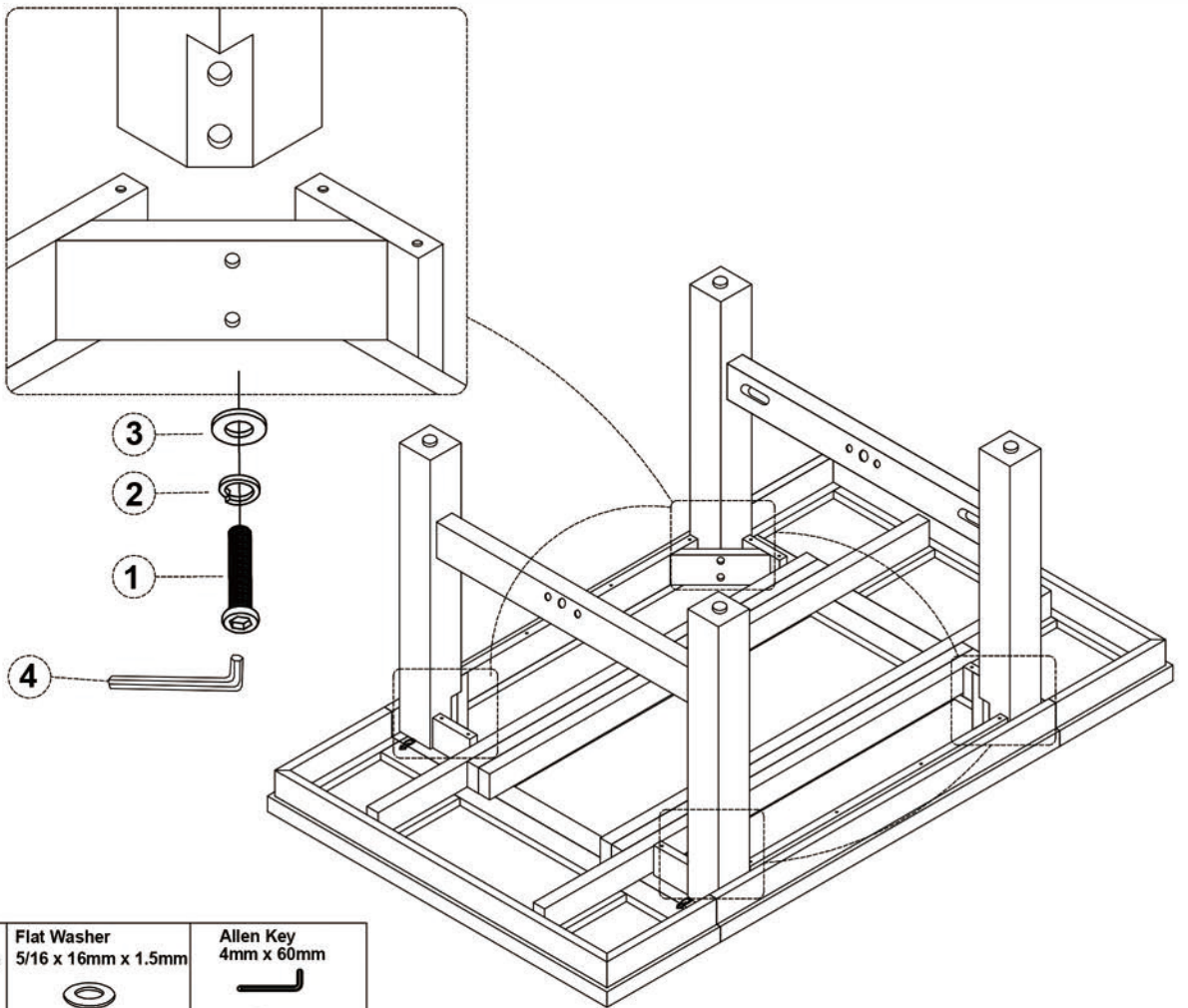

<b>Bolts</b> 5/16 x 50mm  ① x 4	<b>Spring Washer</b> 5/16 x 13mm x 1.5mm  ② x 4	<b>Flat Washer</b> 5/16 x 16mm x 1.5mm  ③ x 4	<b>Allen Key</b> 4mm x 60mm  ④ x 1
--	---	---	--

# STEP 2



<b>Bolts</b> 5/16 x 50mm  ① x 8	<b>Spring Washer</b> 5/16 x 13mm x 1.5mm  ② x 8	<b>Flat Washer</b> 5/16 x 16mm x 1.5mm  ③ x 8	<b>Allen Key</b> 4mm x 60mm  ④ x 1
--	---	---	--

### STEP 3

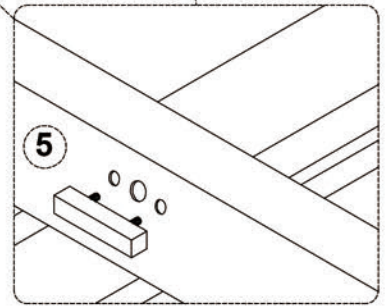
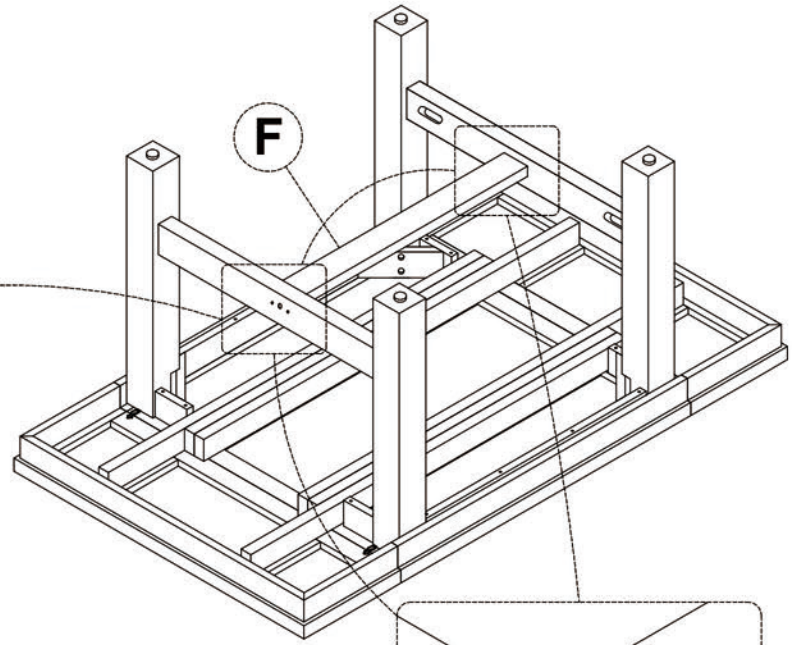
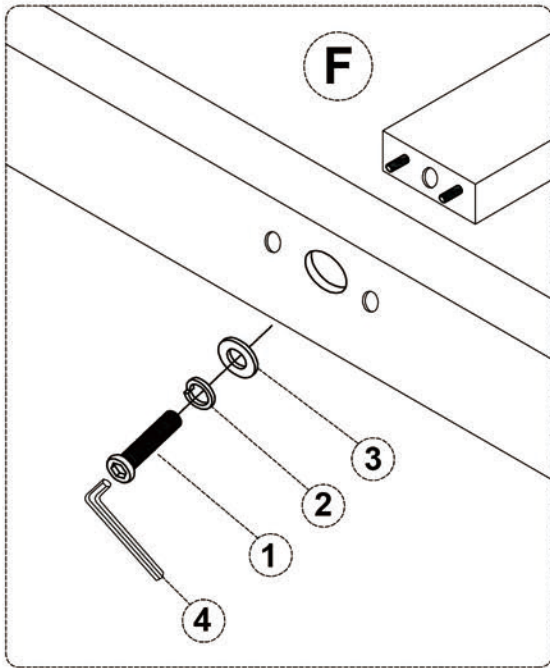

Bolts  
5/16 x 50mm



① x 2

Spring Washer  
5/16 x 13mm x 1.5mm



② x 2

Flat Washer  
5/16 x 16mm x 1.5mm



③ x 2

Allen Key  
4mm x 60mm



④ x 1

Ornament



⑤ x 2

### FINISH

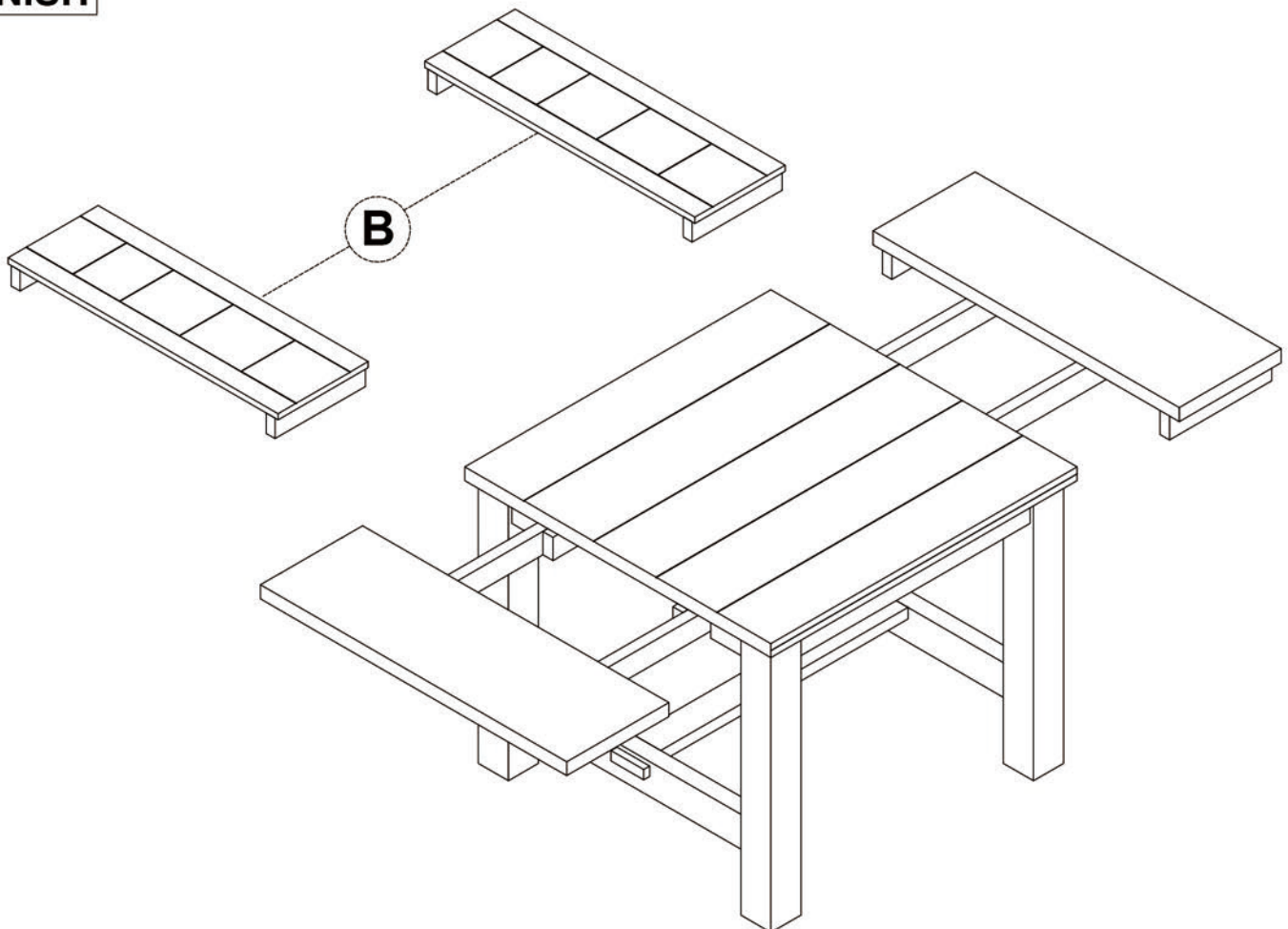

# ASSEMBLY INSTRUCCIONES

ITEM NOTE : WF310633  
DINING CHAIR

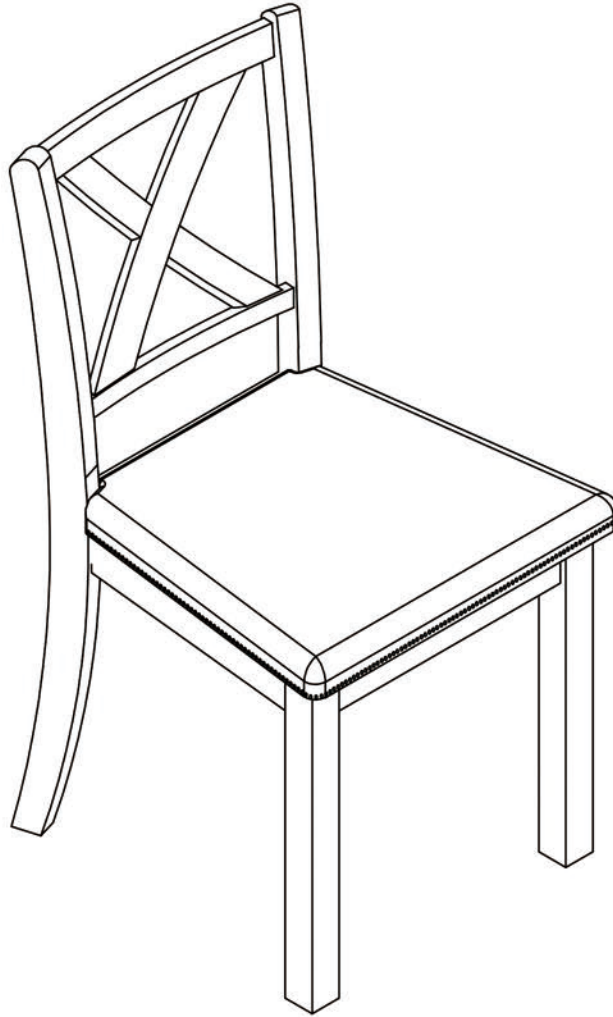





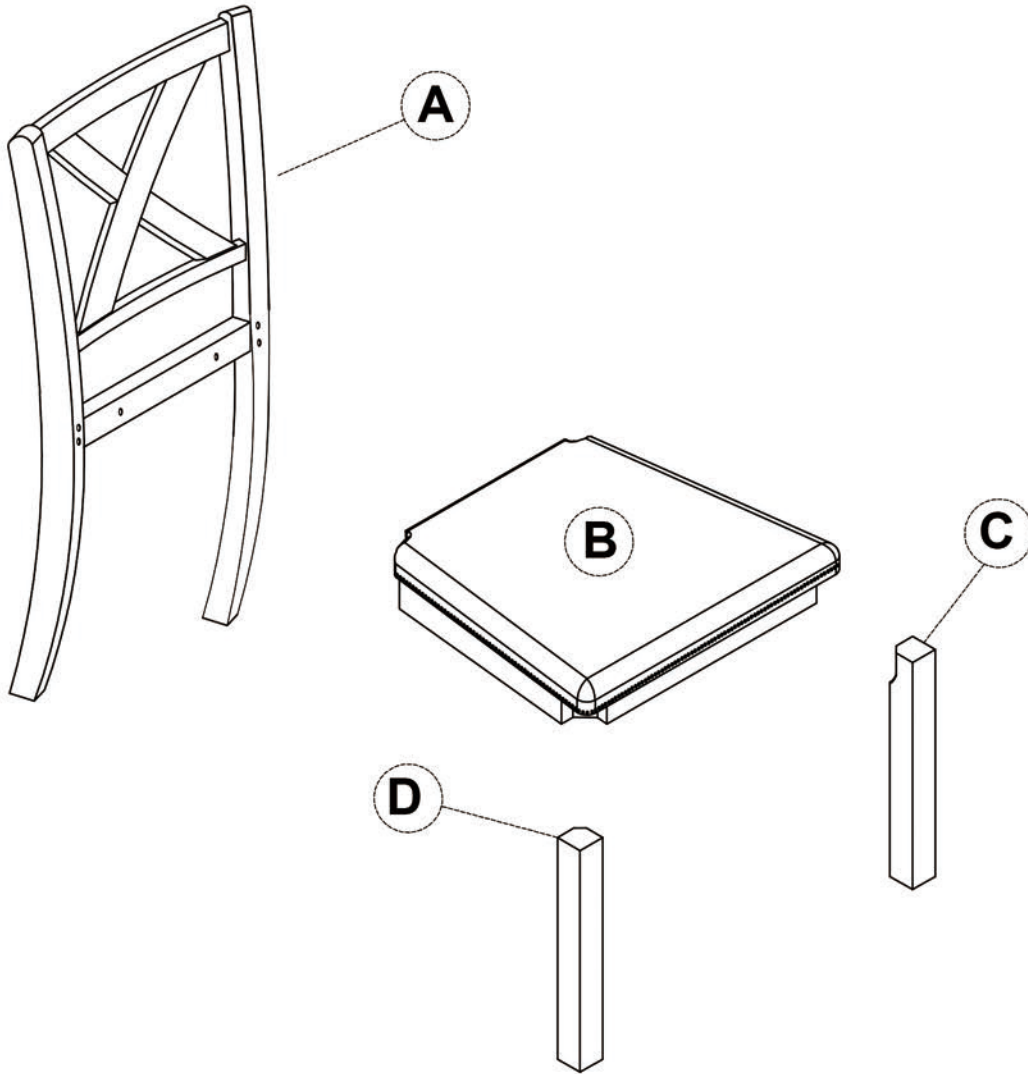



## IMPORTANT NOTE:

- ① PLACE ALL PARTS ON A CLEAN AND SMOOTH SURFACE SUCH AS A RUG OR CARPET TO AVOID THE PARTS FROM BEING SCRATCHED.
- ② BEFORE YOU BEGIN, KINDLY FOLLOW THE ASSEMBLY INSTRUCTIONS STEP BY STEP.
- ③ DO NOT TIGHEN ALL SCREWS AND BOLTS UNTIL THE CHAIR IS FULLY STEP-UP







### Part List For One

### Hardware List For One

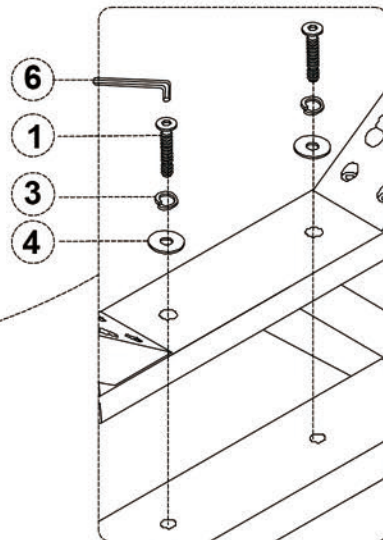
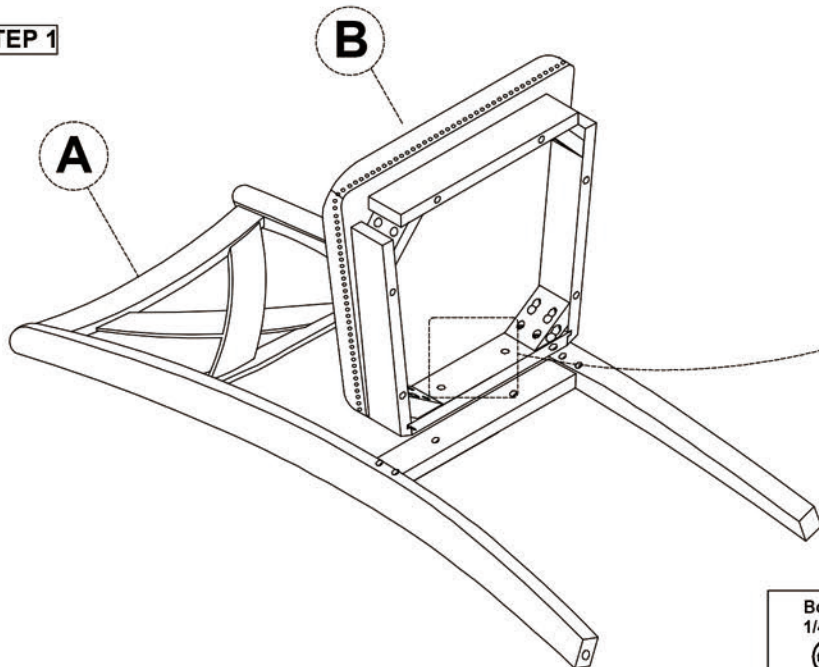
No	Parts Desc.	Q'ty	No	Hardware Desc.	Q'ty
A	BACK FRAME 	1pcs	1	Bolts 1/4" x 35mm 	2pcs
			2	Bolts 1/4" x 75mm 	4pcs
B	SEAT FRAME 	1pcs	3	Spring Washer 1/4" x 13mm x 1.5mm 	10pcs
			4	Flat Washer 1/4" x 16mm x 1.5mm 	10pcs
C	FRONT LEGS 	2pcs	5	Bolts 1/4" x 50mm 	4pcs
			6	Allen Key 4mm x 60mm 	1pcs





**STEP 1**

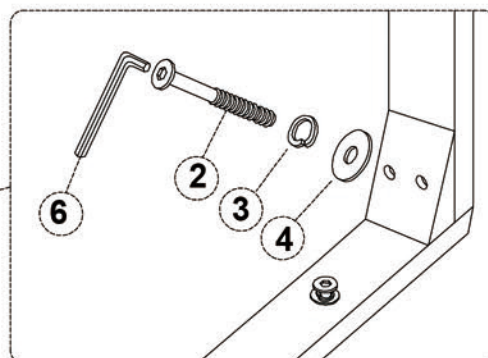
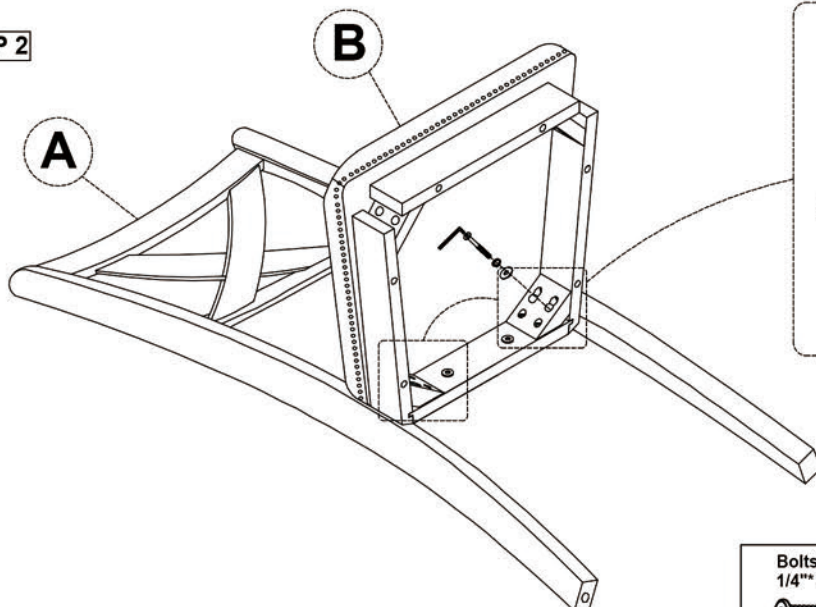

<b>Bolts</b> 1/4" 35mm  ① x 2	<b>Spring Washer</b> 1/4" x 13mm x 1.5mm  ③ x 2	<b>Flat Washer</b> 1/4" x 16mm x 1.5mm  ④ x 2	<b>Allen Key</b> 4mm x 60mm  ⑥ x 1
---	---	---	--





**STEP 2**

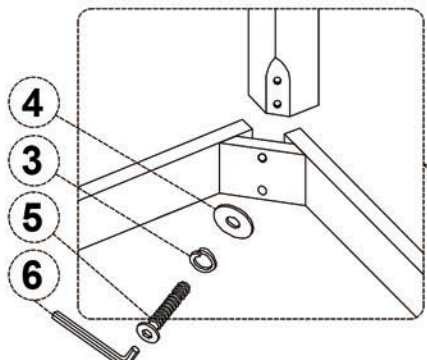
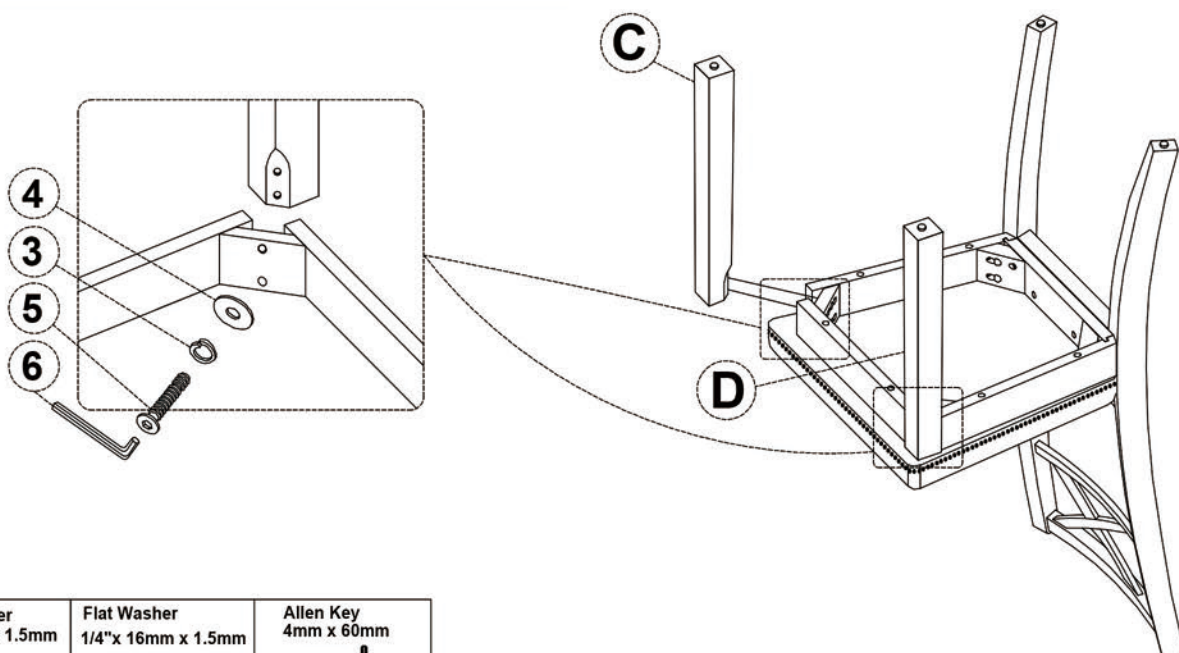

<b>Bolts</b> 1/4" 75mm  ② x 4	<b>Spring Washer</b> 1/4" x 13mm x 1.5mm  ③ x 4	<b>Flat Washer</b> 1/4" x 16mm x 1.5mm  ④ x 4	<b>Allen Key</b> 4mm x 60mm  ⑥ x 1
---	---	---	--

**STEP 3**



<b>Bolts</b> 1/4" 50mm  ⑤ x 4	<b>Spring Washer</b> 1/4" x 13mm x 1.5mm  ③ x 4	<b>Flat Washer</b> 1/4" x 16mm x 1.5mm  ④ x 4	<b>Allen Key</b> 4mm x 60mm  ⑥ x 1
--	---	---	--

# ASSEMBLY INSTRUCCIONES

ITEM NOTE : WF310634

BENCH

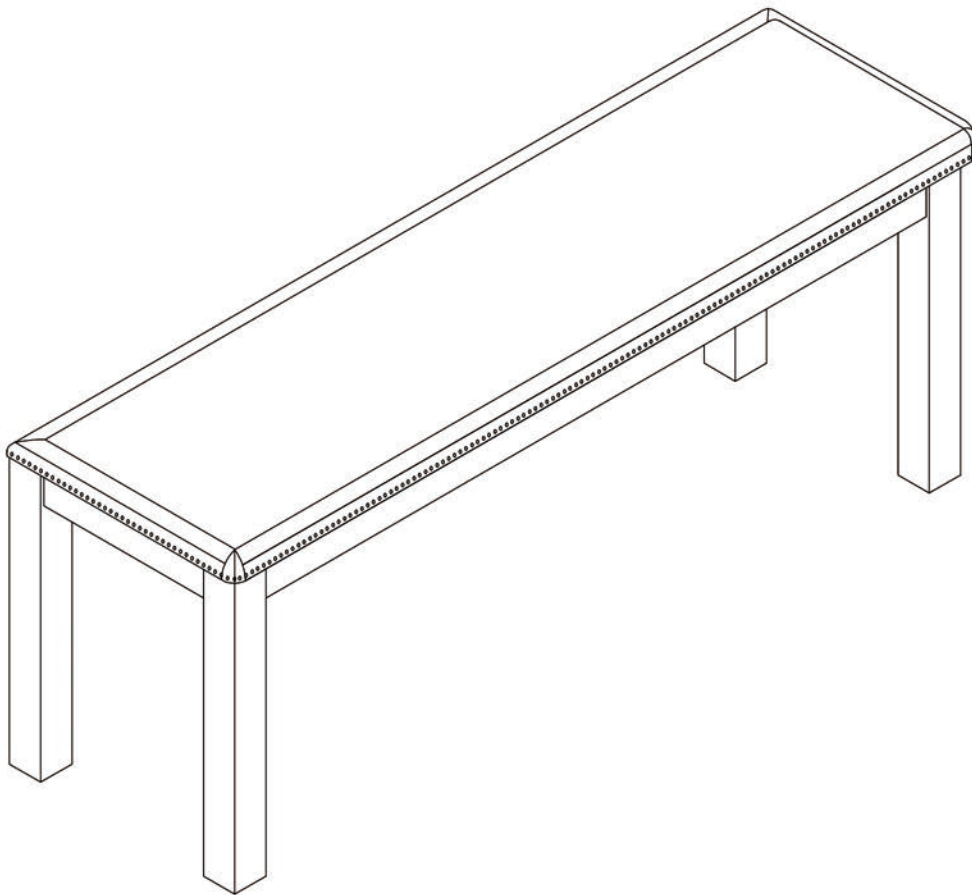





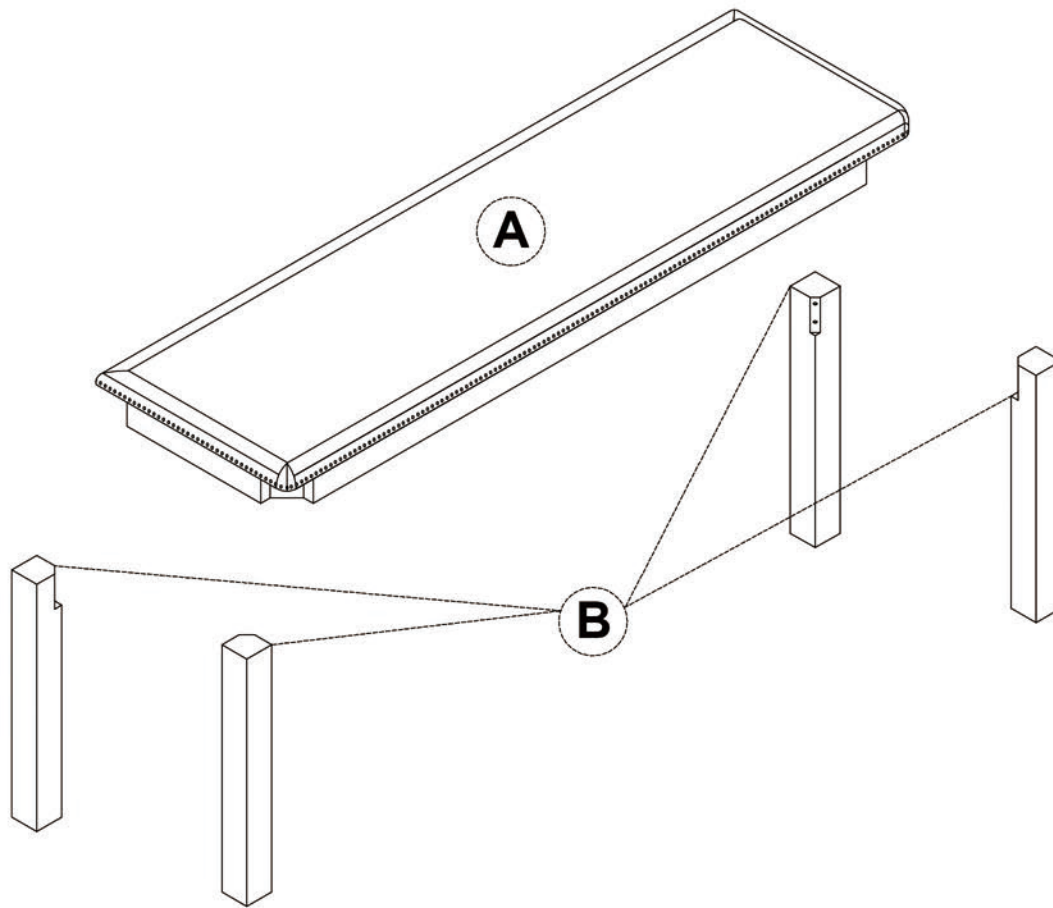

## IMPORTANT NOTE:

- ① PLACE ALL PARTS ON A CLEAN AND SMOOTH SURFACE SUCH AS A RUG OR CARPET TO AVOID THE PARTS FROM BEING SCRATCHED.
- ② BEFORE YOU BEGIN, KINDLY FOLLOW THE ASSEMBLY INSTRUCTIONS STEP BY STEP.
- ③ DO NOT TIGHEN ALL SCREWS AND BOLTS UNTIL THE BENCH IS FULLY STEP-UP



**Part List For One**

**Hardware List For One**

No	Parts Desc.	Q'ty	No	Hardware Desc.	Q'ty
A	SEAT FRAME 	1pcs	1	Bolts 1/4" x 50mm 	8pcs
			2	Spring Washer 1/4" x 13mm x 1.5mm 	8pcs
			3	Flat Washer 1/4" x 16mm x 1.5mm 	8pcs
B	LEGS 	4pcs	4	Allen Key 4mm x 60mm 	1pcs

**STEP 1**

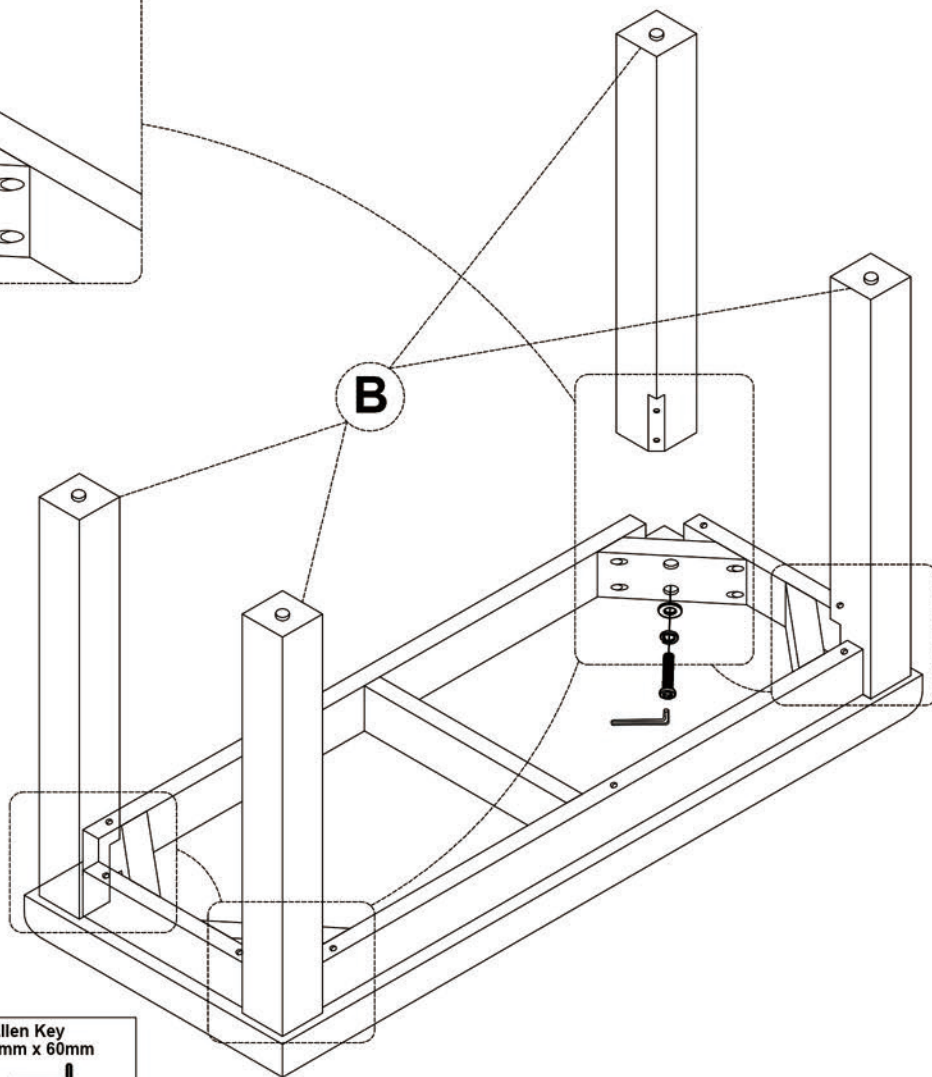
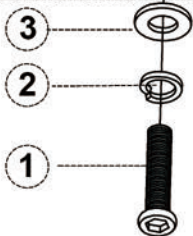
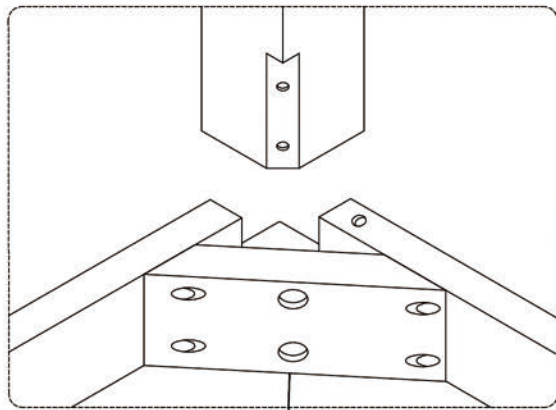

**Bolts**  
1/4" x 50mm



① x 8

**Spring Washer**  
1/4" x 13mm x 1.5mm



② x 8

**Flat Washer**  
1/4" x 16mm x 1.5mm



③ x 8

**Allen Key**  
4mm x 60mm



④ x 1

**FINISH**

