

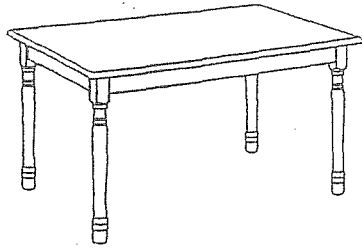



# ASSEMBLY INSTRUCTION



|   | PARTS LIST | QTY.   |
|---|------------|--------|
| A | TABLE TOP  | 1 pc.  |
| B | TABLE LEG  | 4 pcs. |

|   | HARDWARE LIST  | QTY.   |
|---|--|--------|
| C | ALLEN KEY           | 1 pc.  |
| D | M6 x 60 JCBC SCREW  | 8 pcs. |
| E | SPRING WASHER       | 8 pcs. |
| F | FLAT WASHER         | 8 pcs. |

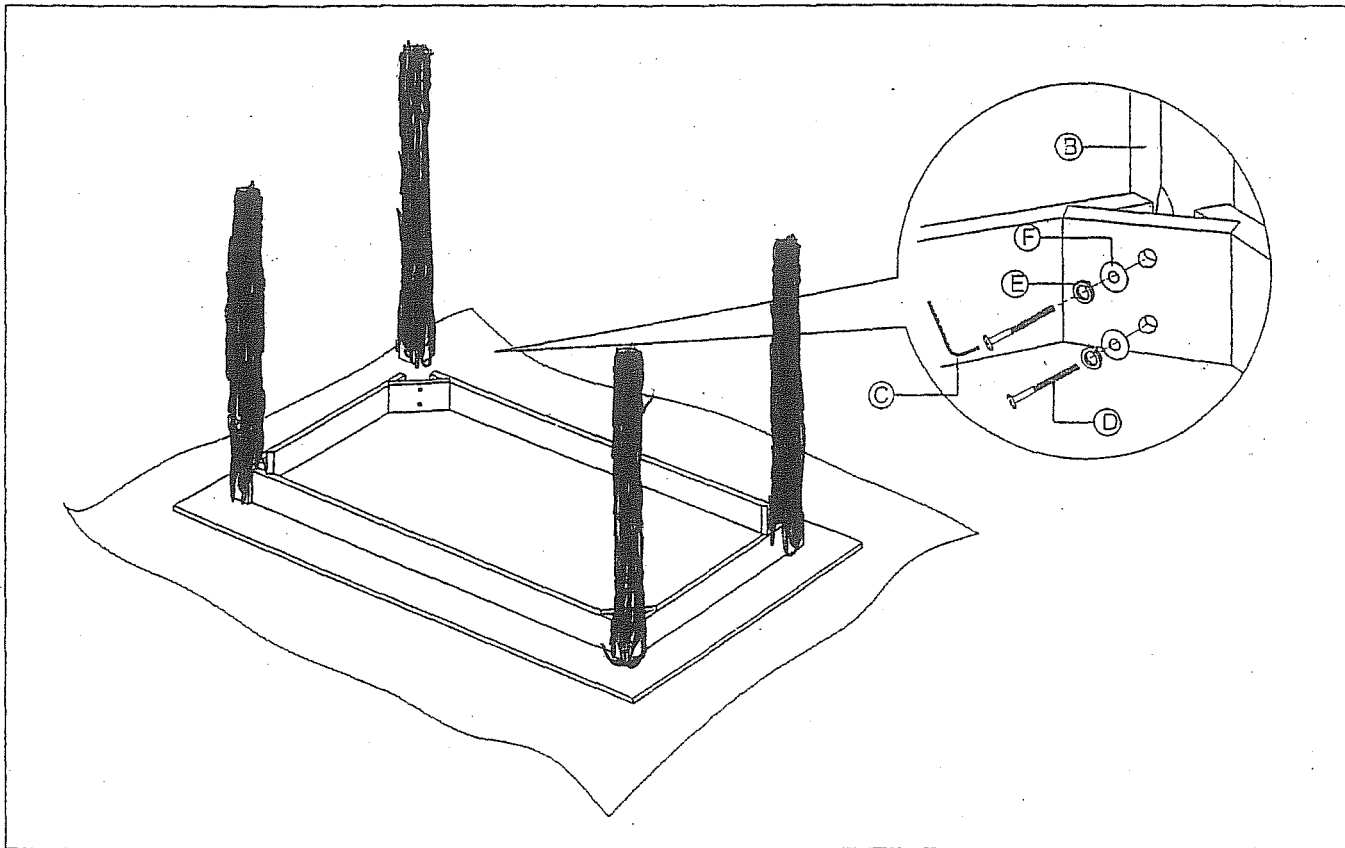

## STEP 1

Position the Table Top (A) upside down on a soft flat surface to prevent scratches.

## STEP 2

Attach Table Leg (B) to the corner of Table Top (A). Align the holes, use JCBC Screw (D), Spring Washer (E) and Flat Washer (F) to assemble them together. Tighten it with Allen Key (C).