

Assembly | Asambla | Assemblage

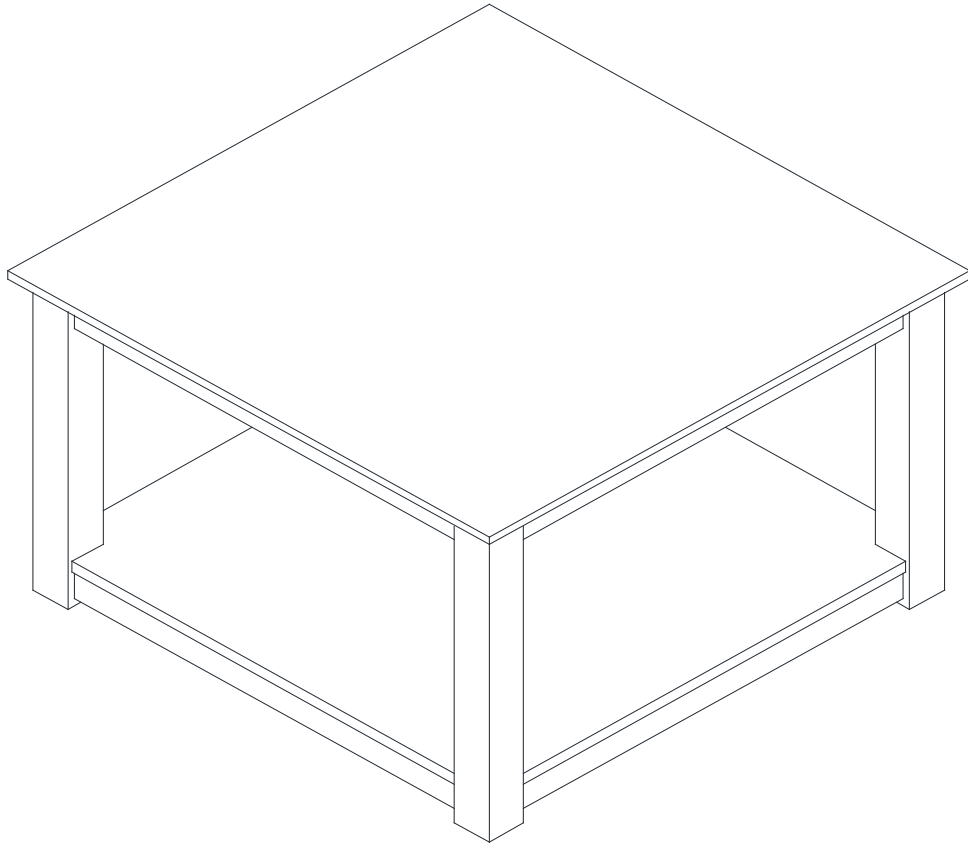

Assembly | Asamblea | Assemblage

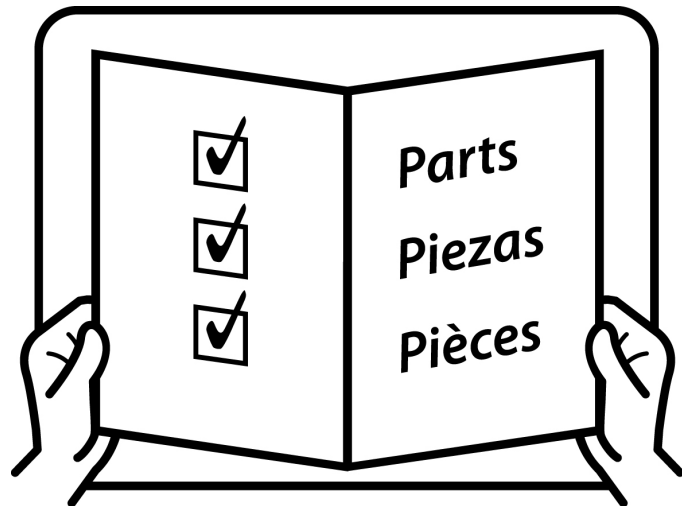
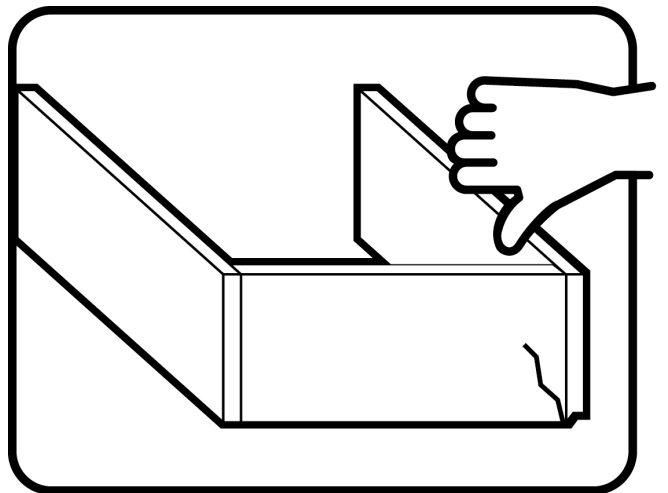
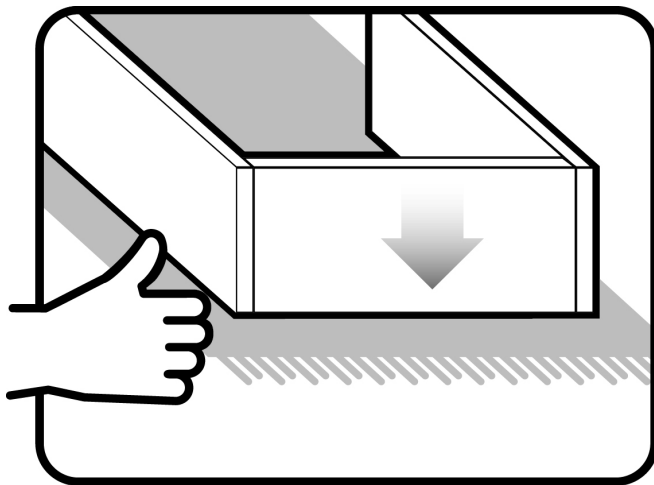
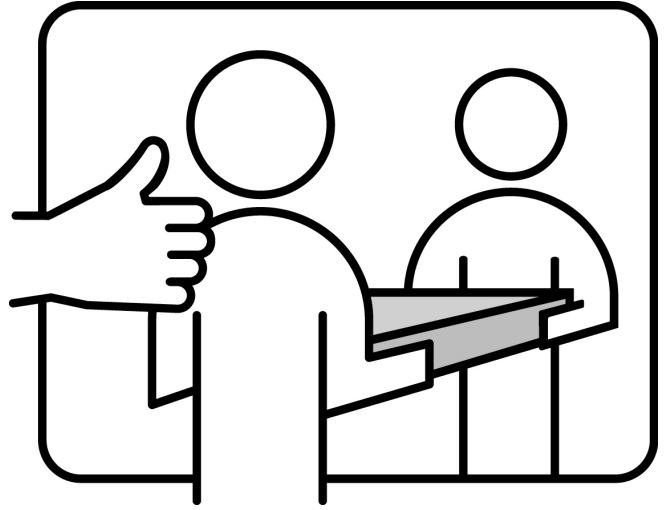
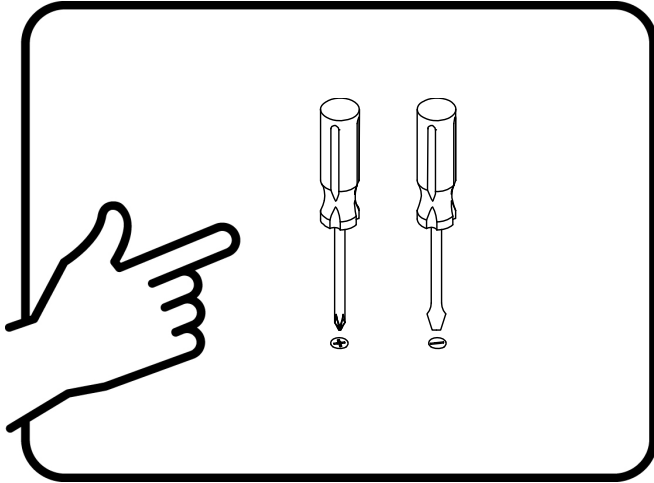

Assembly | Asamblea | Assemblage

Techniques | Técnicas | Techniques

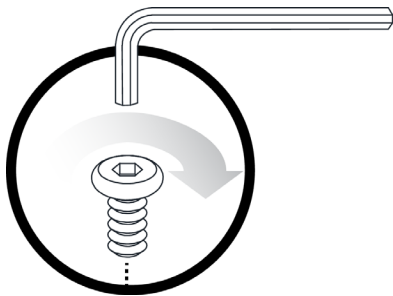

Care | Cuidado | Entretien



Safety | Seguridad | Sécurité







Note! | ¡Nota! | Remarque!

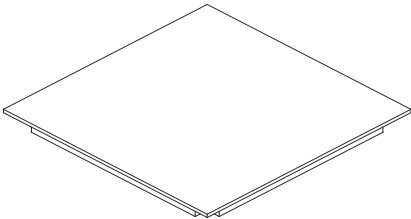
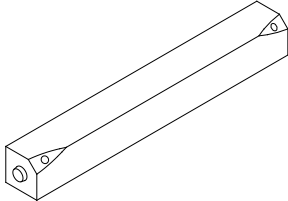
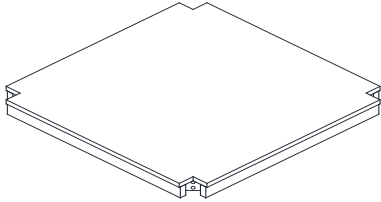

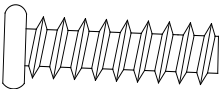
Assembly | Asambla | Assemblage

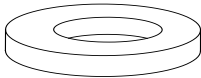
<p>A x1</p>  <p>Top panel Panel superior Panneau supérieur</p>	<p>B x4</p>  <p>Leg Pierna Jambe</p>	<p>C x1</p>  <p>Bottom panel Panel inferior Panneau du bas</p>
--	--	--

<p>1 x8</p>  <p>Bolt Tornillo Boulon Ø1/4"x1-3/4"</p>	<p>2 x8</p>  <p>Spring washer Arandela de resorte Rondelle à ressort</p>	<p>3 x8</p>  <p>Flat washer Arandela plana Rondelle plate</p>
--	--	---

<p>4. x1</p>  <p>Allen wrench Llave allen Clé allen</p>

Assembly | Asambla | Assemblage

1

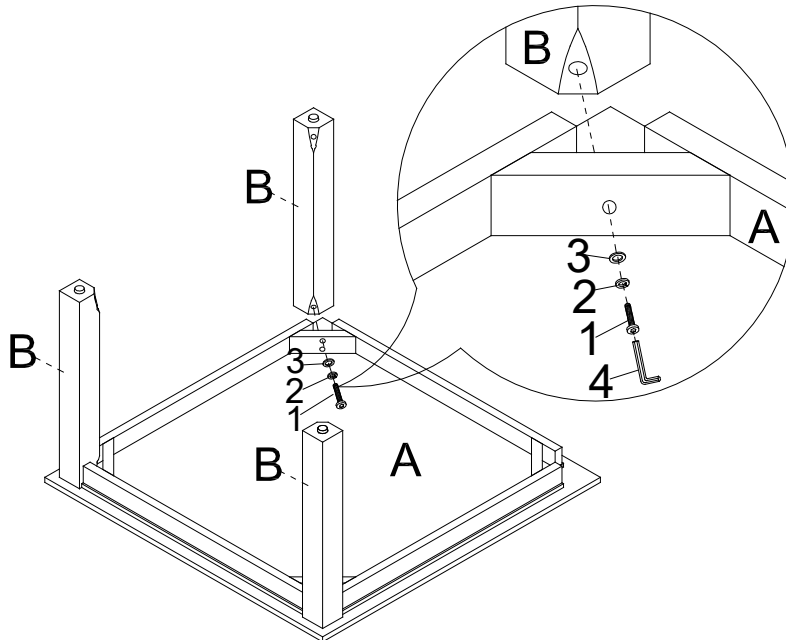

1		X3
2		X3
3		X3
4		X1

Do not fully tighten screws until all screws are in position.

No apriete completamente los tornillos hasta que estén en su posición.

Ne serrez pas complètement les vis tant que toutes les vis ne sont pas en place.

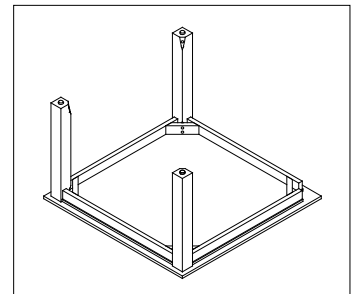

2

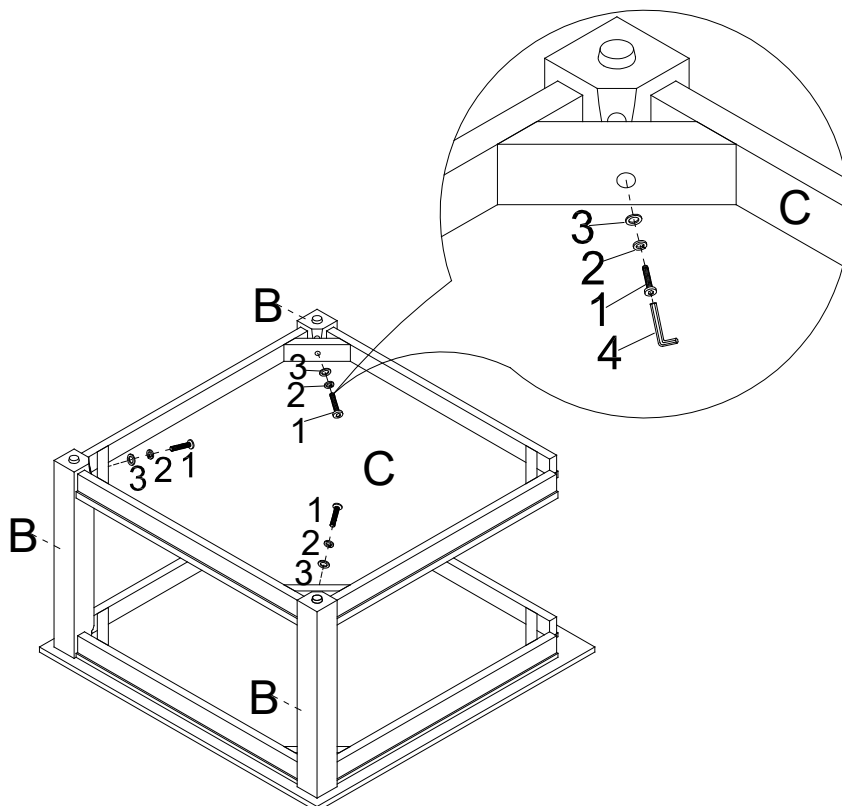

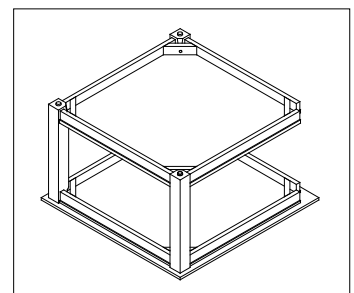

1		X3
2		X3
3		X3



Assembly | Asambla | Assemblage

3

1		X2
2		X2
3		X2

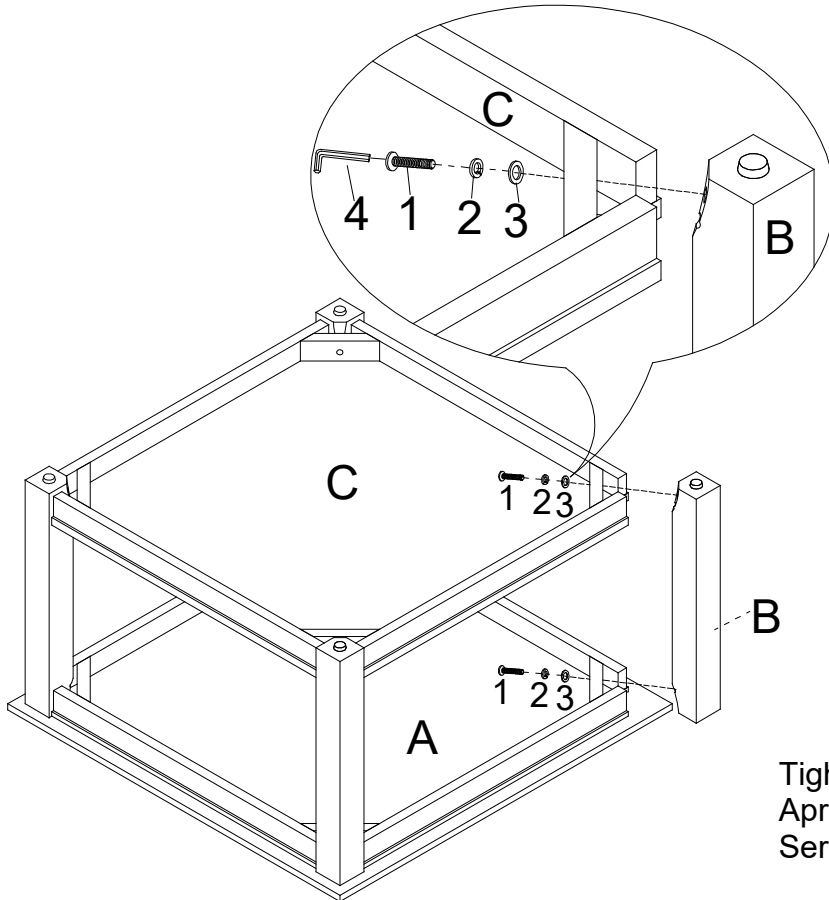

Tighten all screws.
Apretar todos los tornillos.
Serrez toutes les vis.

