

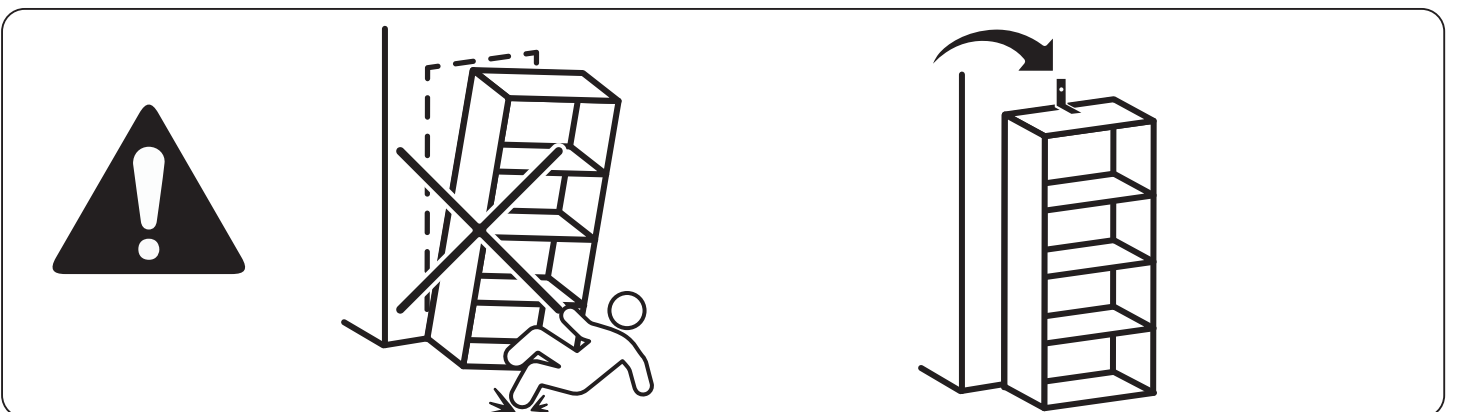

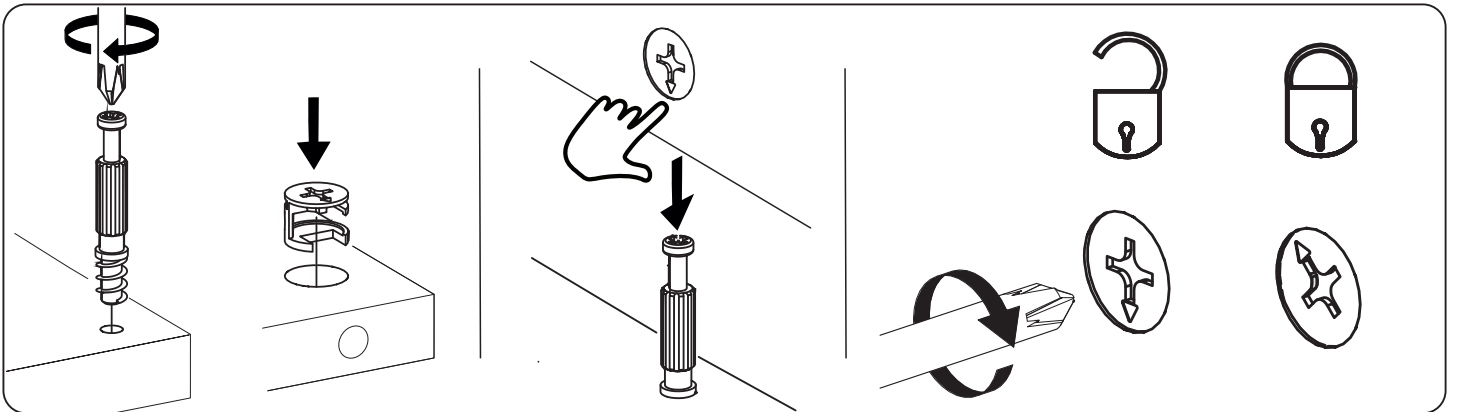

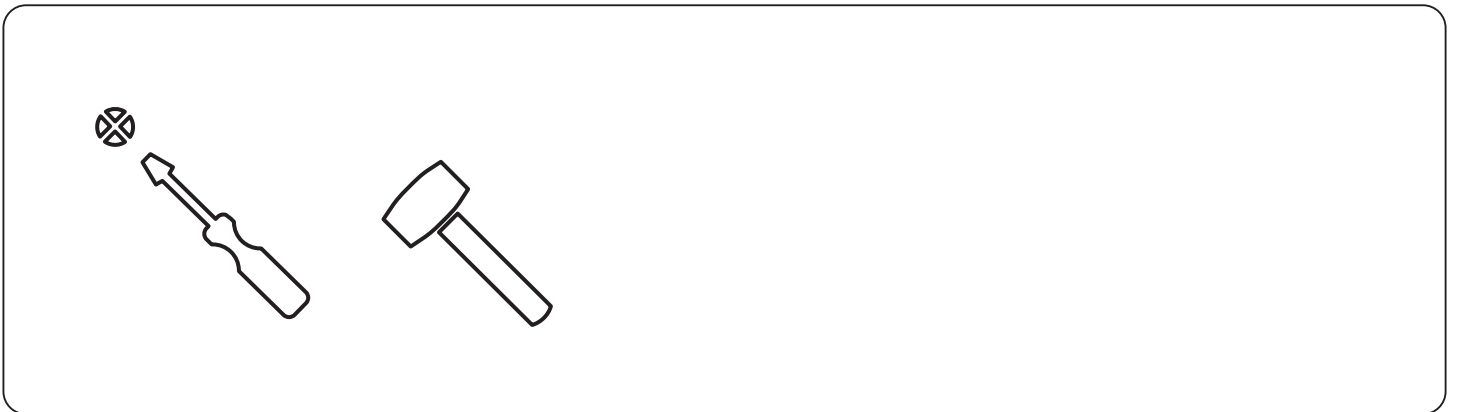

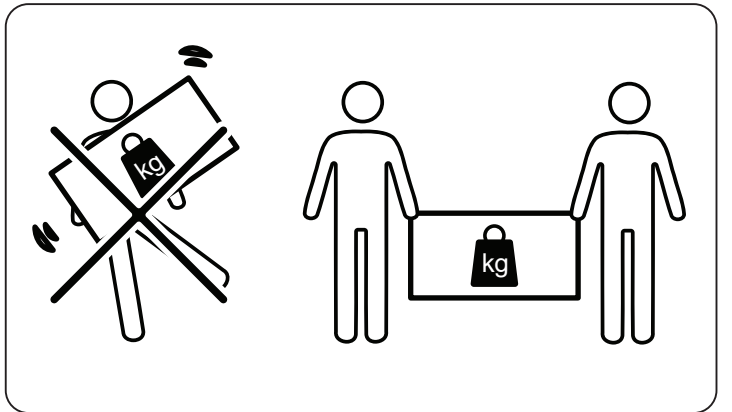
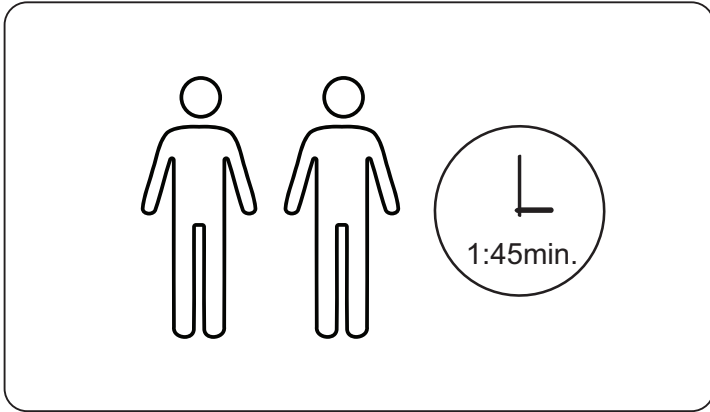
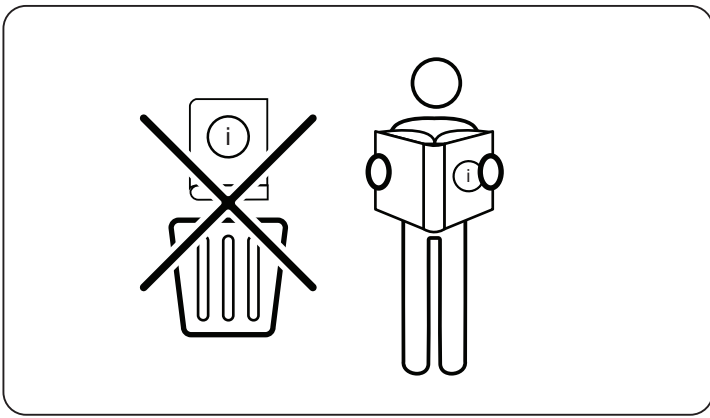
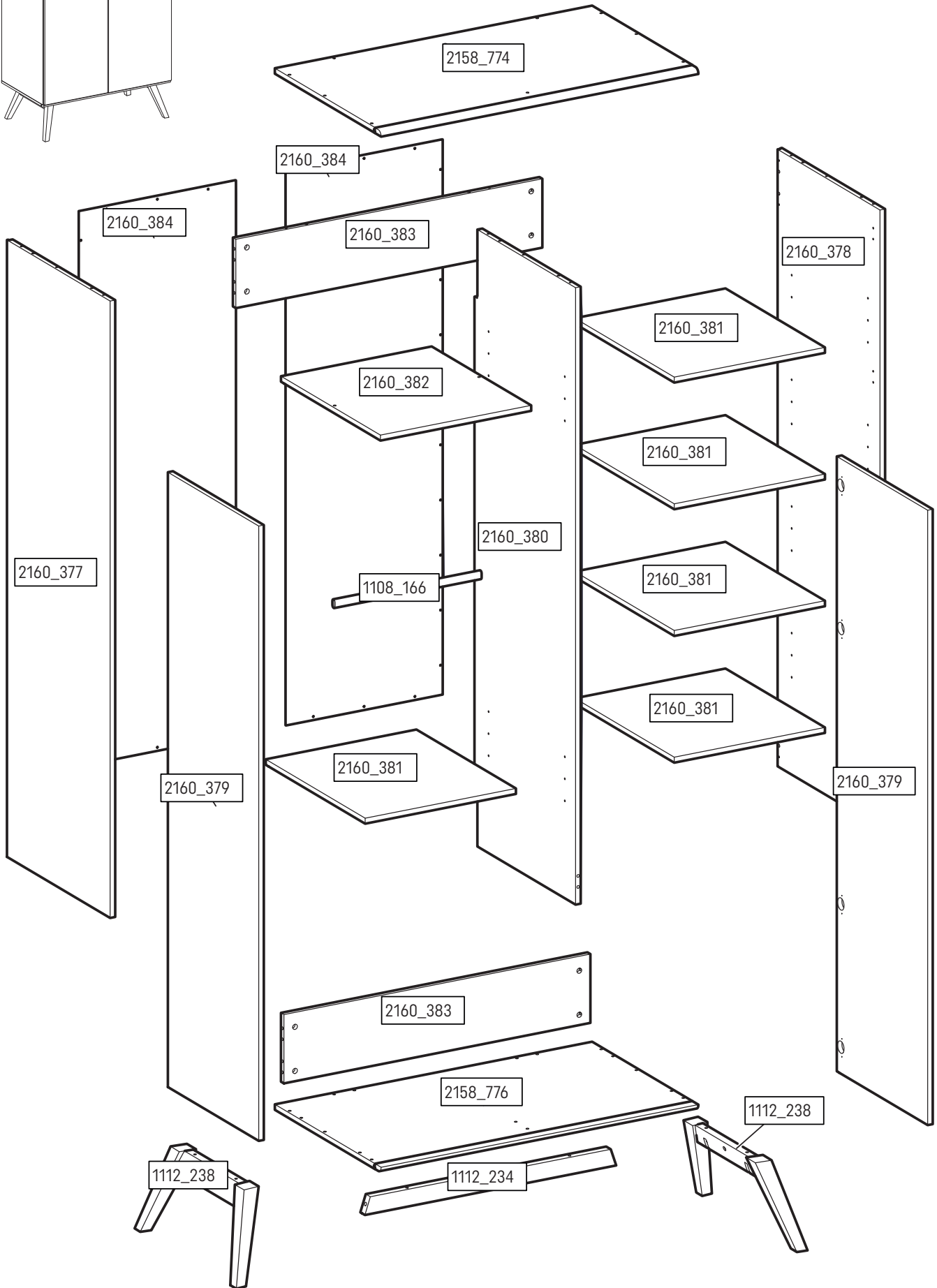
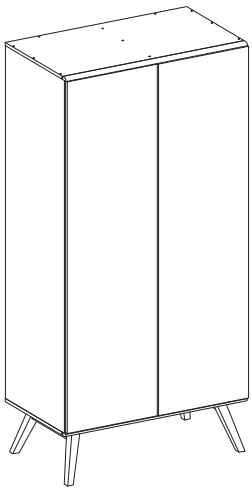

58 cm / 22"

100 cm / 39 1/2"

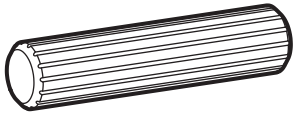
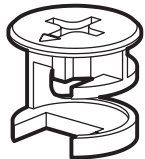
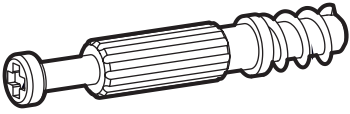
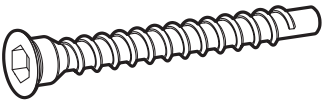
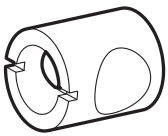
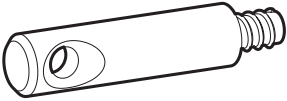
207,4 cm / 82"

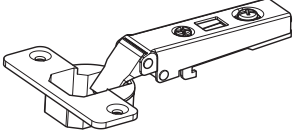
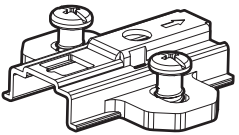
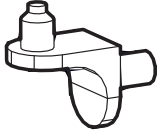
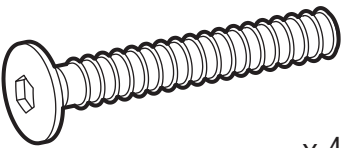
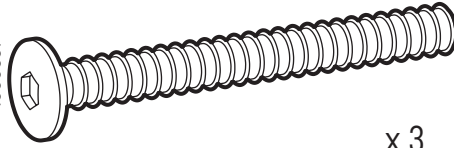
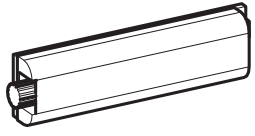
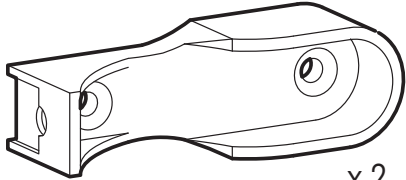

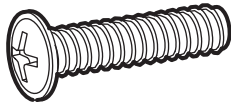
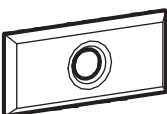

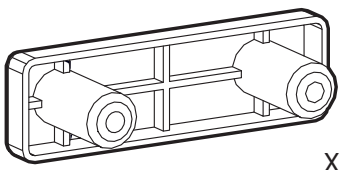
<p>1000806</p>  <p>x 1</p>	<p>1111440</p>  <p>x 1</p>	<p>1005857</p>  <p>x 24</p>
<p>1005367</p>  <p>x 8</p>	<p>1006091</p>  <p>x 8</p>	<p>1005876</p>  <p>x 22</p>
<p>1109473</p>  <p>x 2</p>	<p>1107571</p>  <p>x 2</p>	<p>1109474</p>  <p>x 2</p>
<p>1000197</p>  <p>x 8</p>	<p>1103814</p>  <p>x 8</p>	<p>1001262</p>  <p>x 24</p>
<p>1005377</p>  <p>x 4</p>	<p>1005687</p>  <p>x 3</p>	<p>1107731</p>  <p>x 2</p>
<p>1000225</p>  <p>x 2</p>	<p>1000893</p>  <p>x 1</p>	<p>1005681</p>  <p>x 20</p>
<p>1110778</p>  <p>x 2</p>	<p>1000242</p>  <p>x 10</p>	<p>1006012</p>  <p>x 42</p>
<p>1000868</p>  <p>x 1</p>		

i

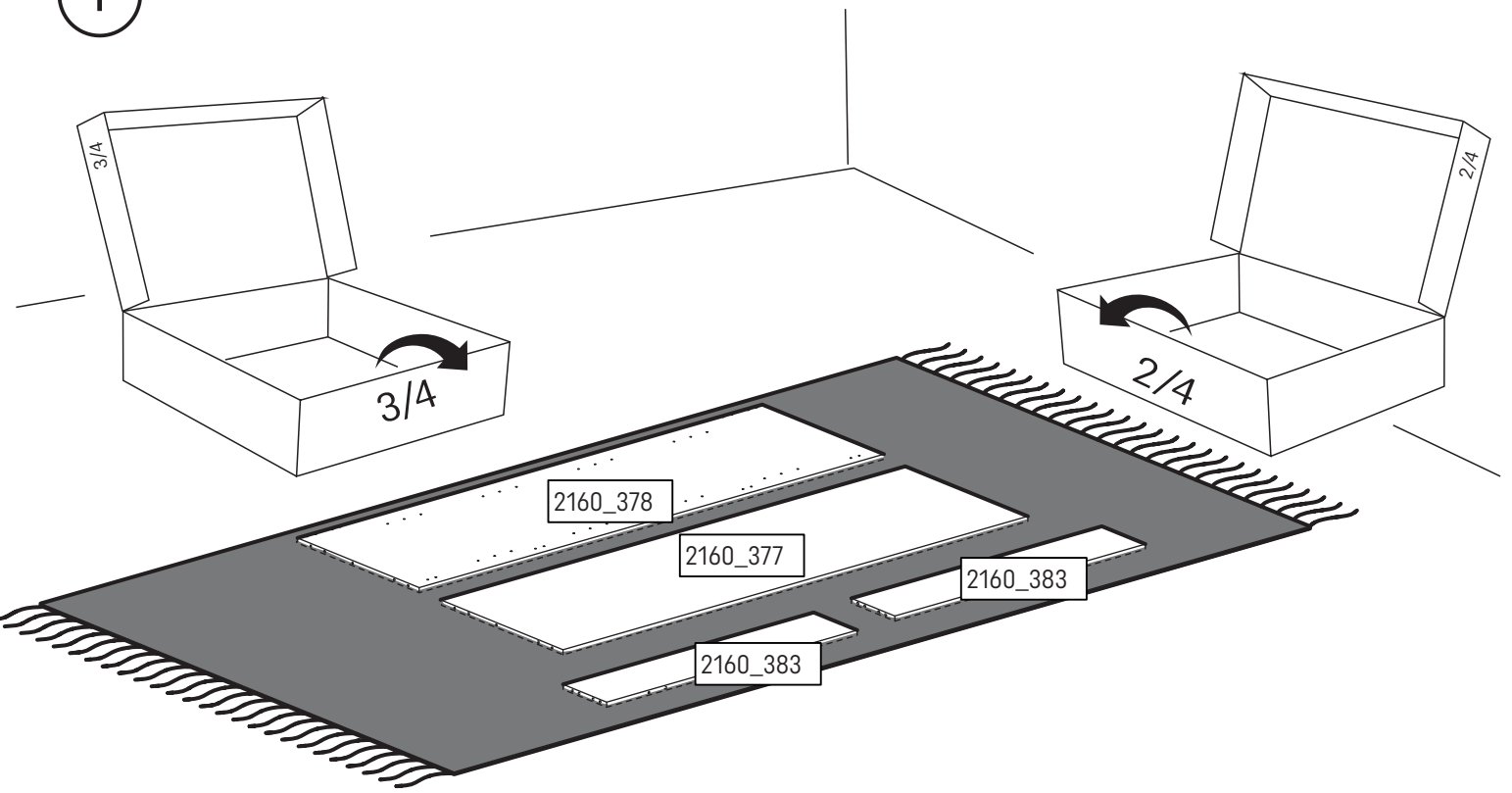

1

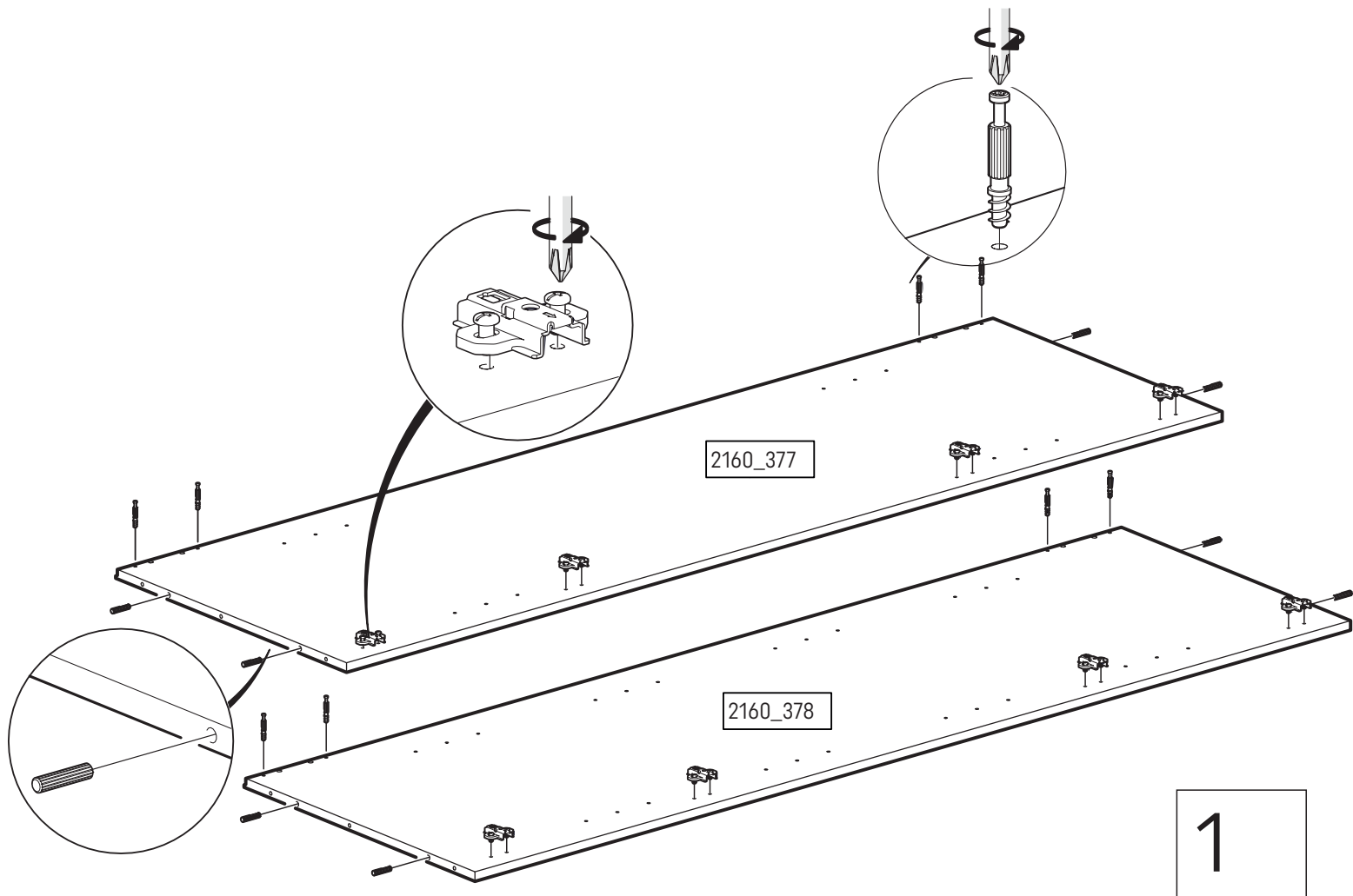
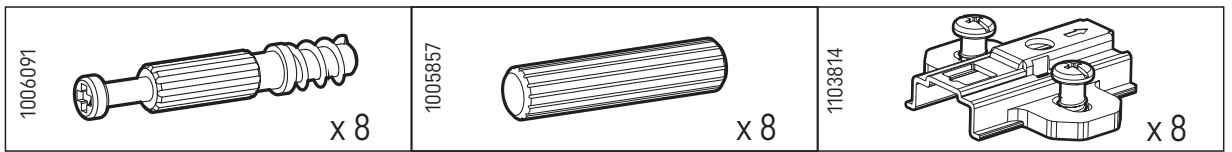

2

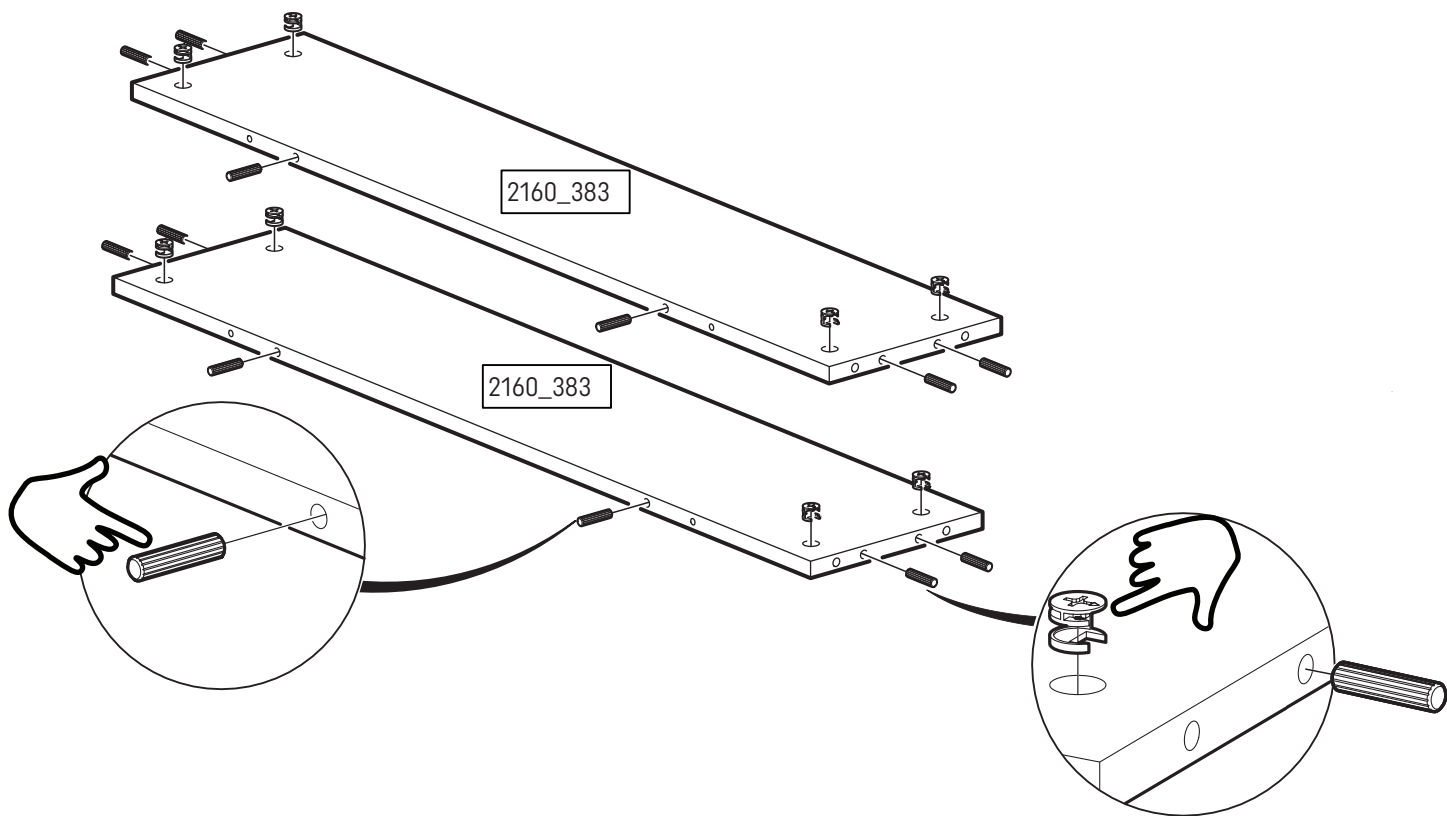
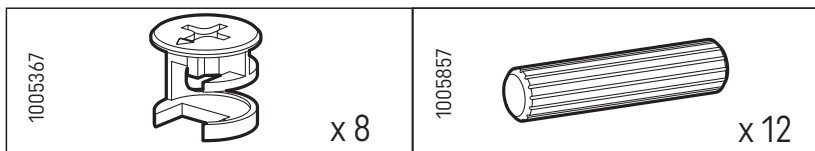

3

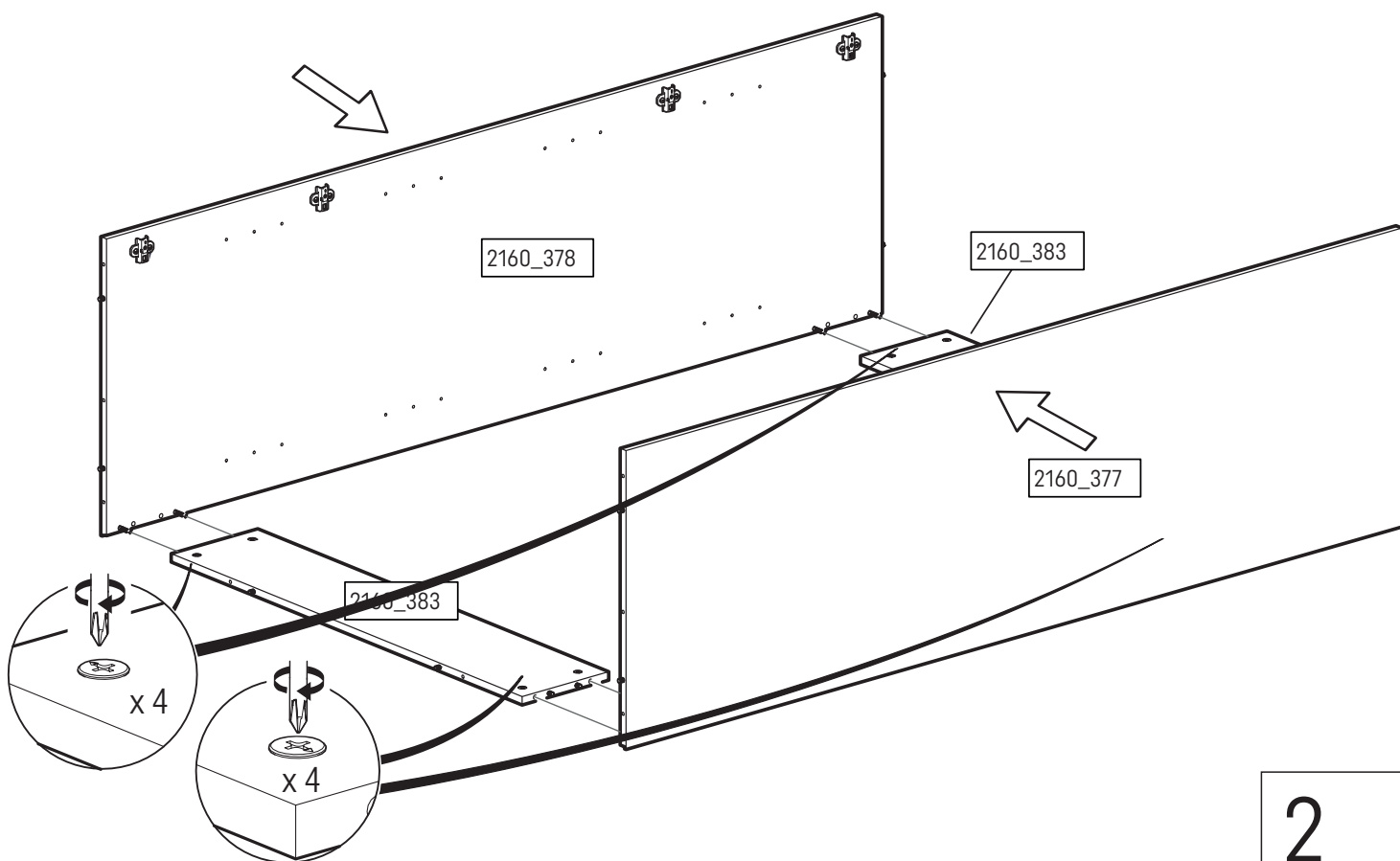
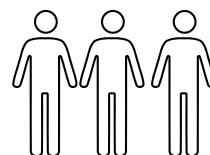

2

i

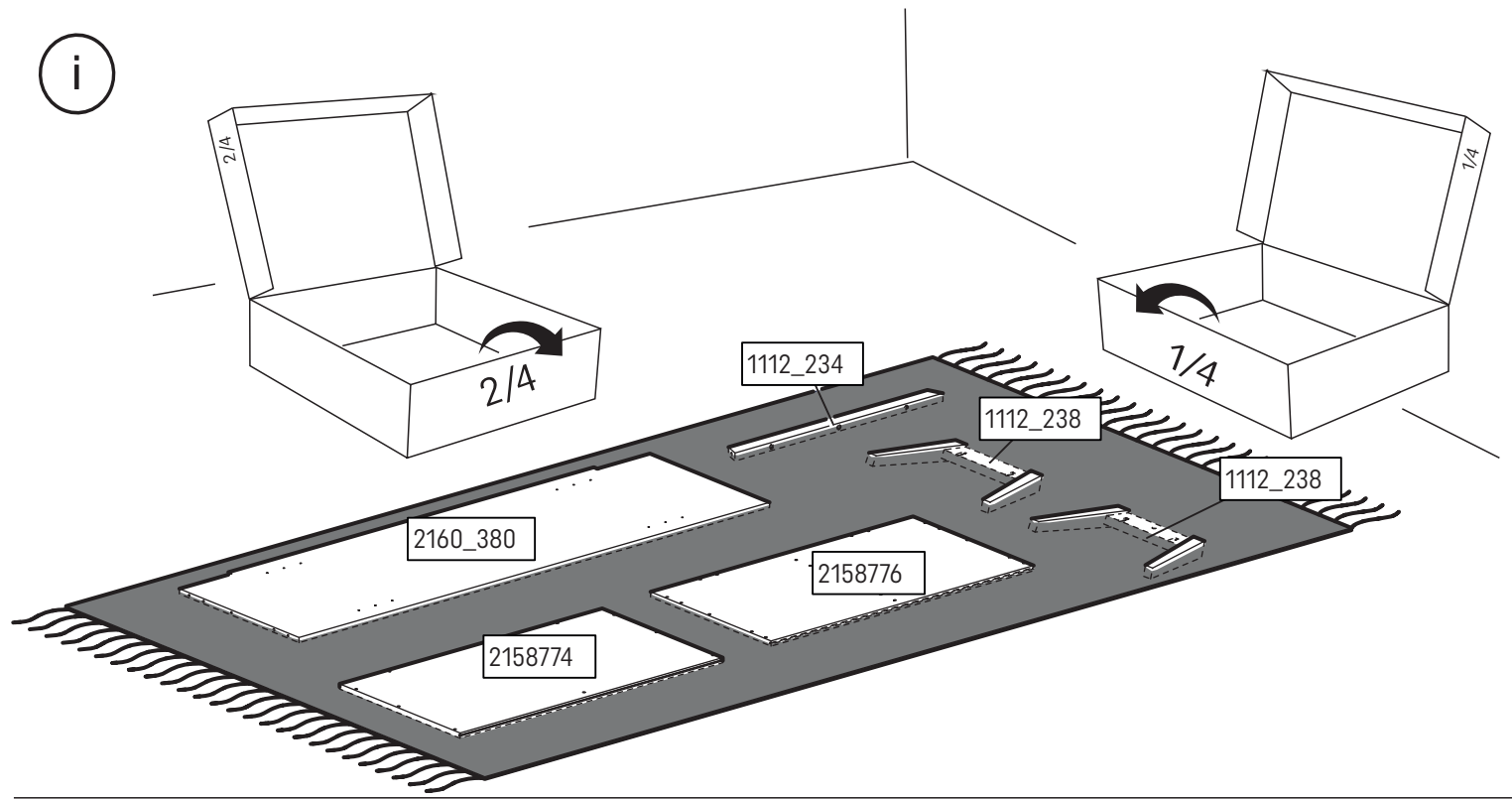

4

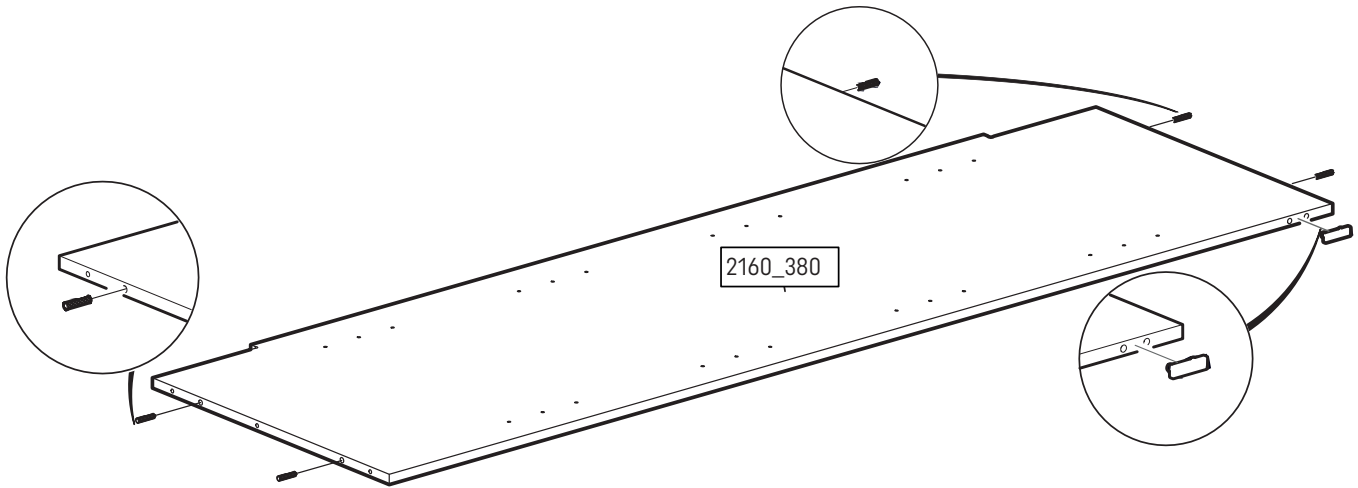
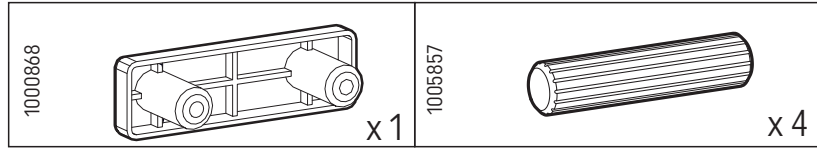

5

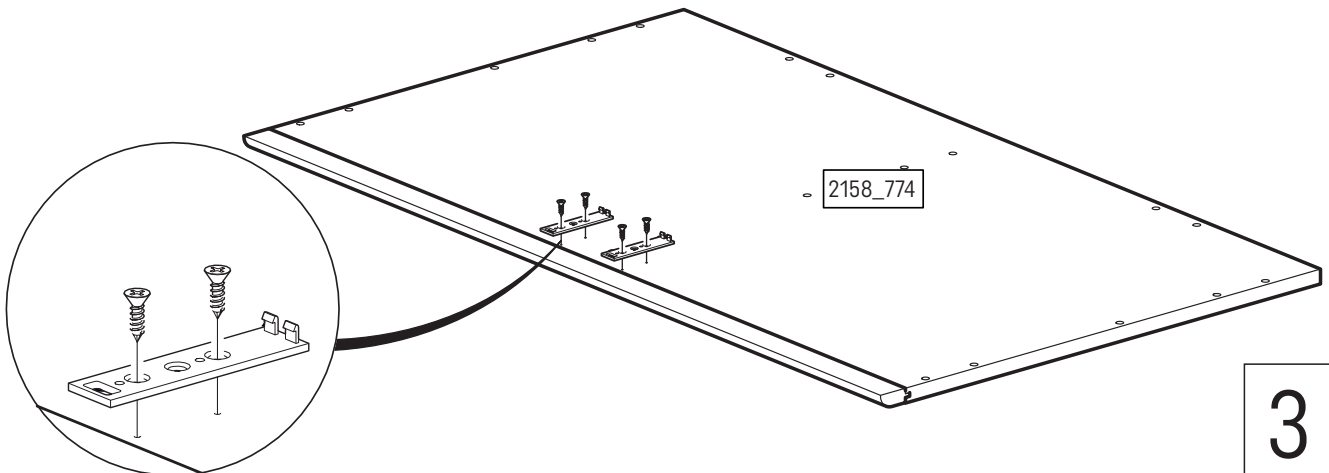
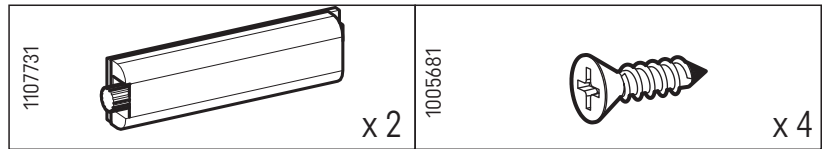

3

6

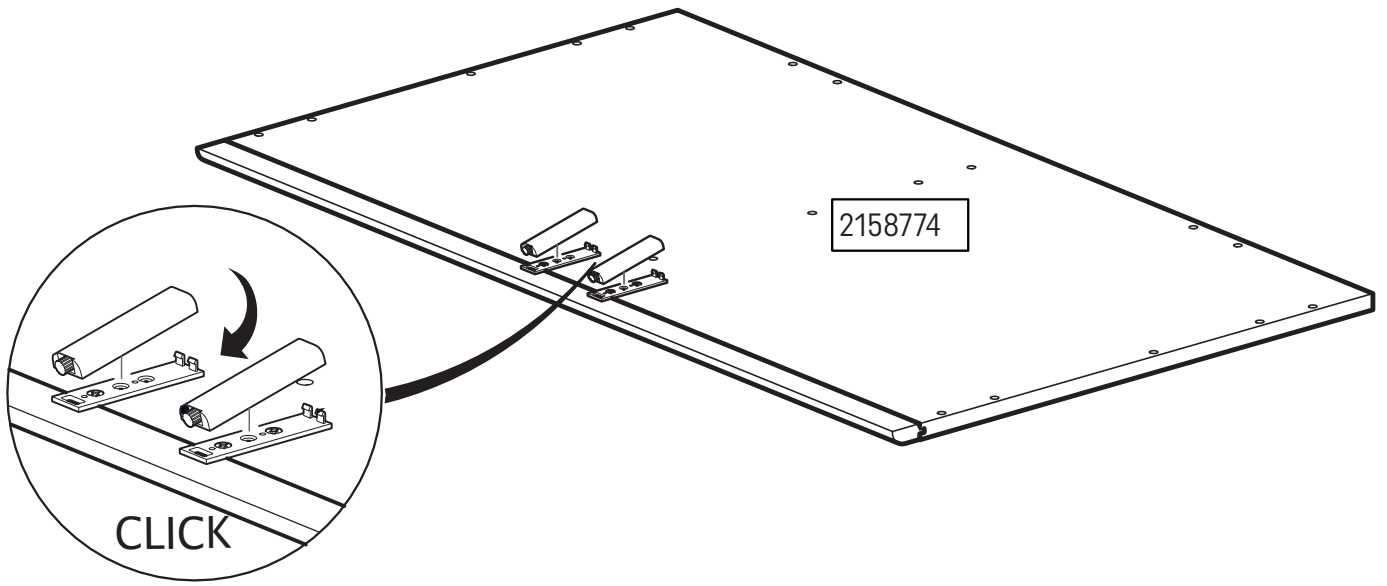

7

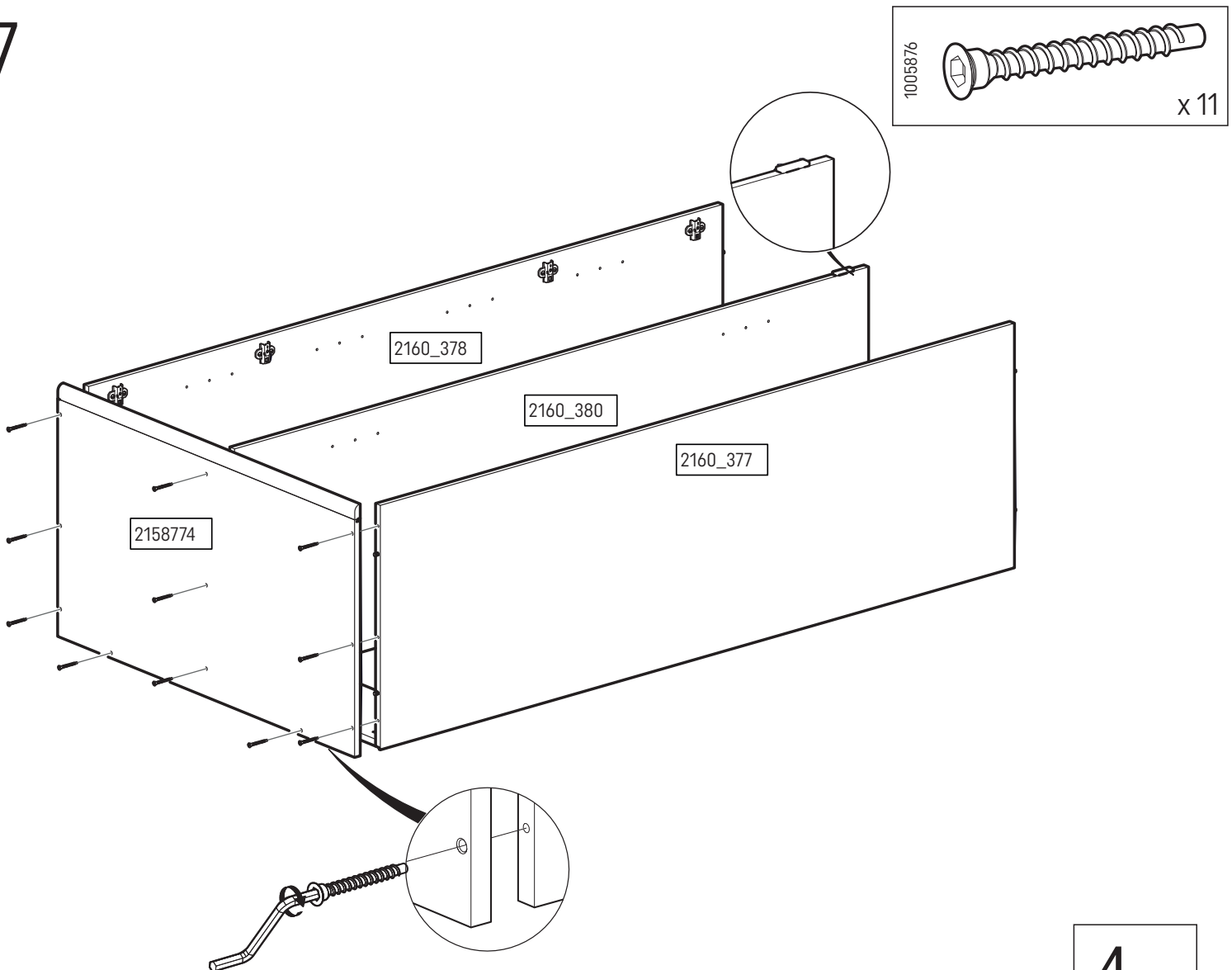

4

8

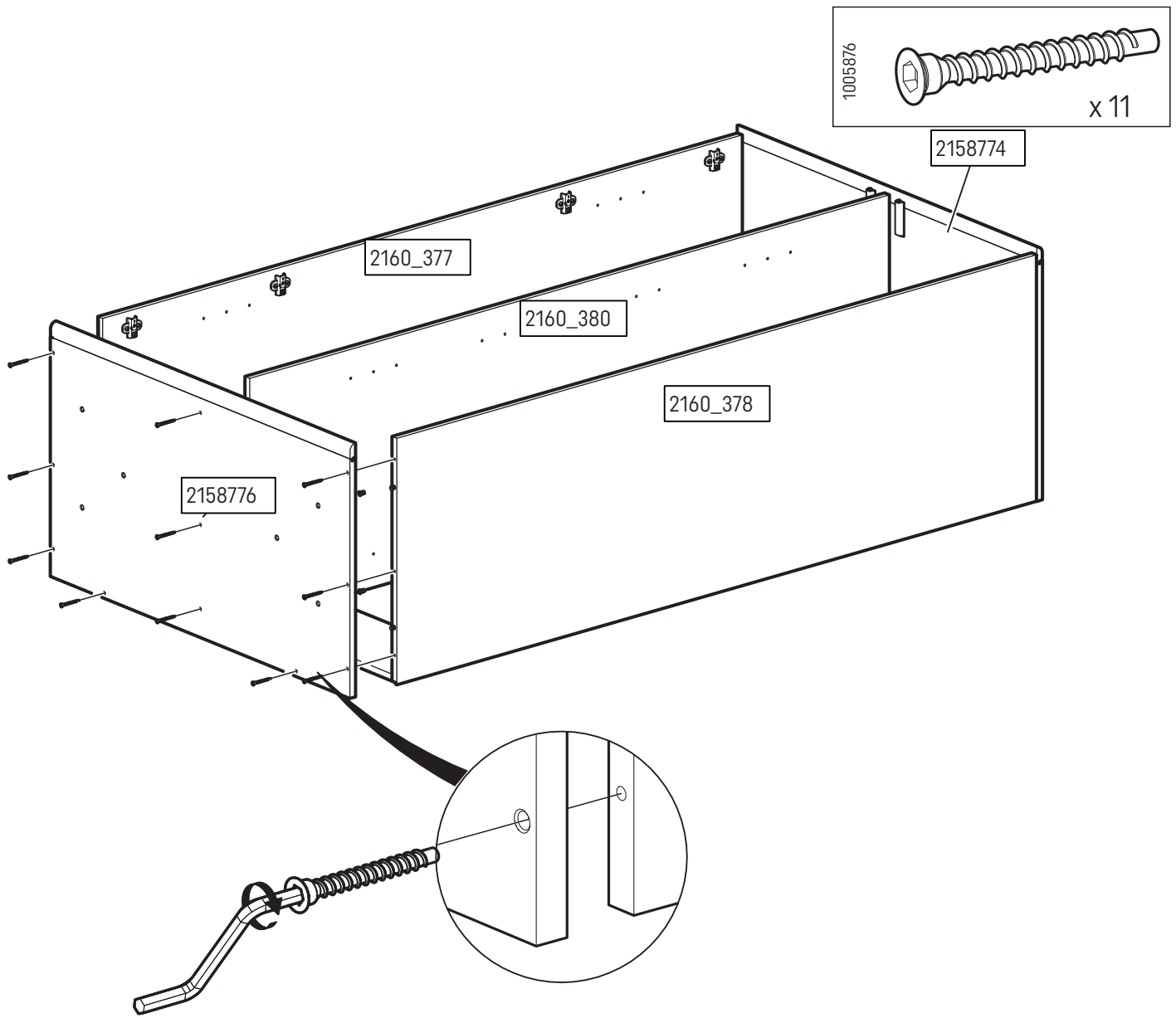

9

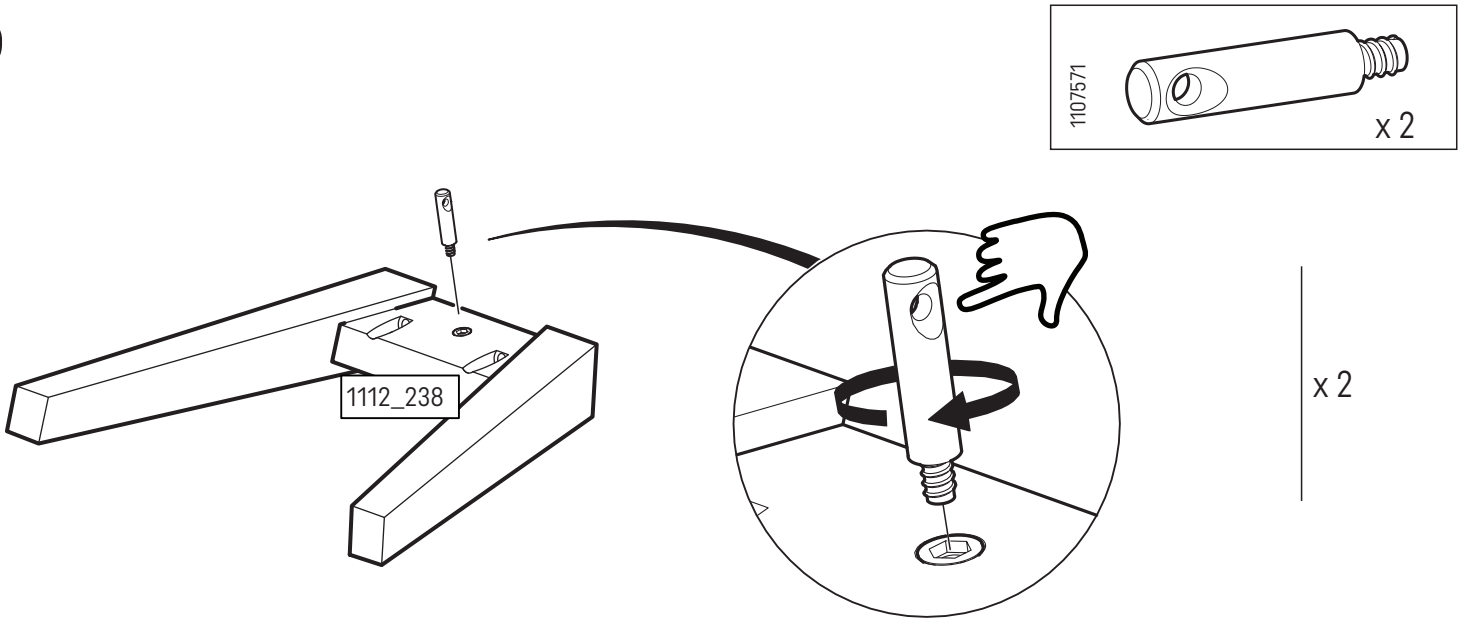

5

10

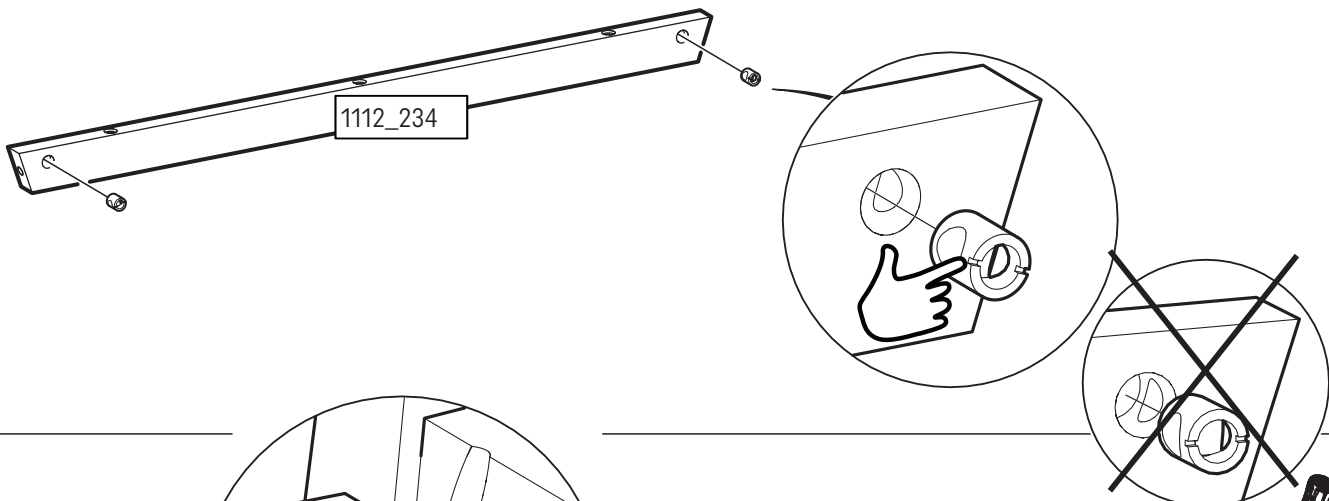
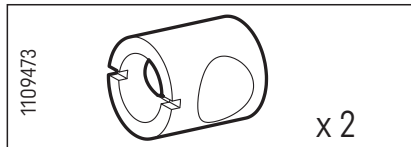

11

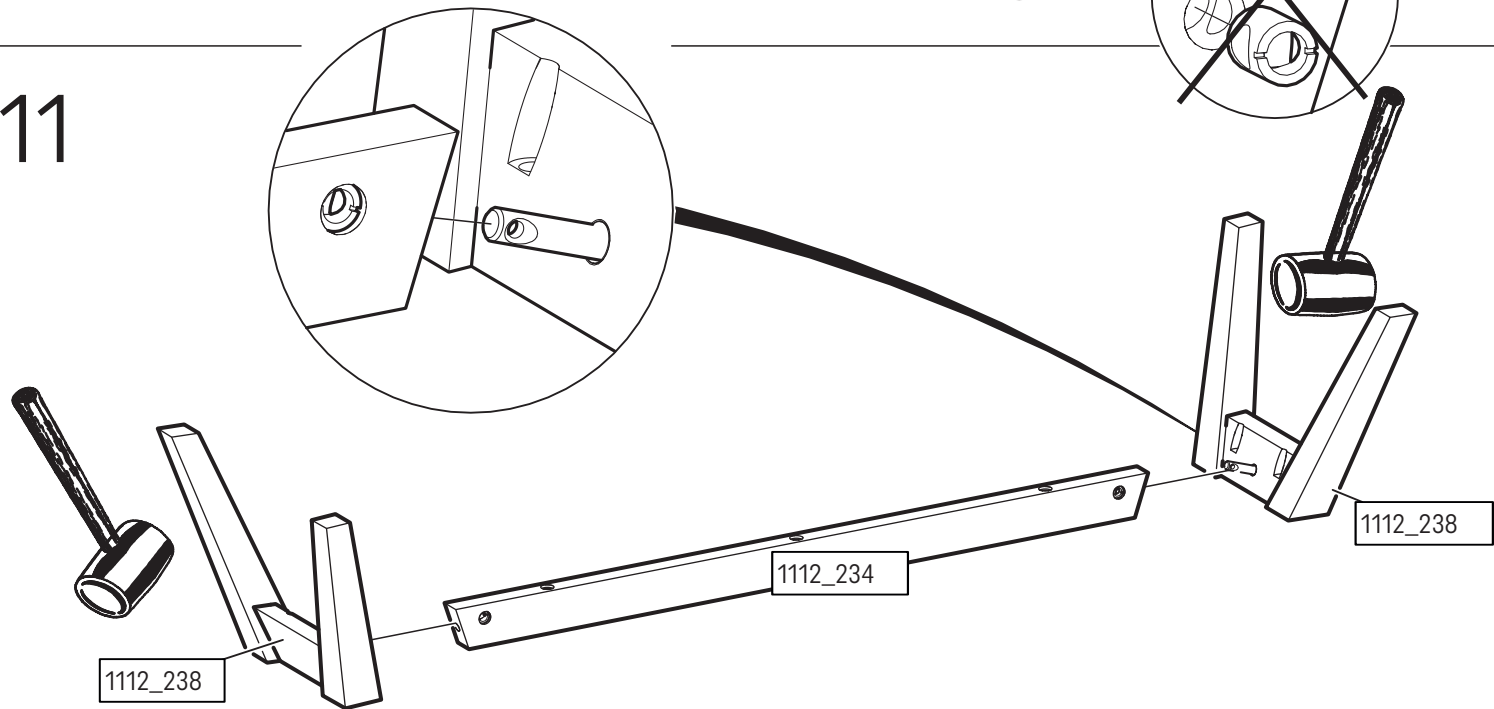

12

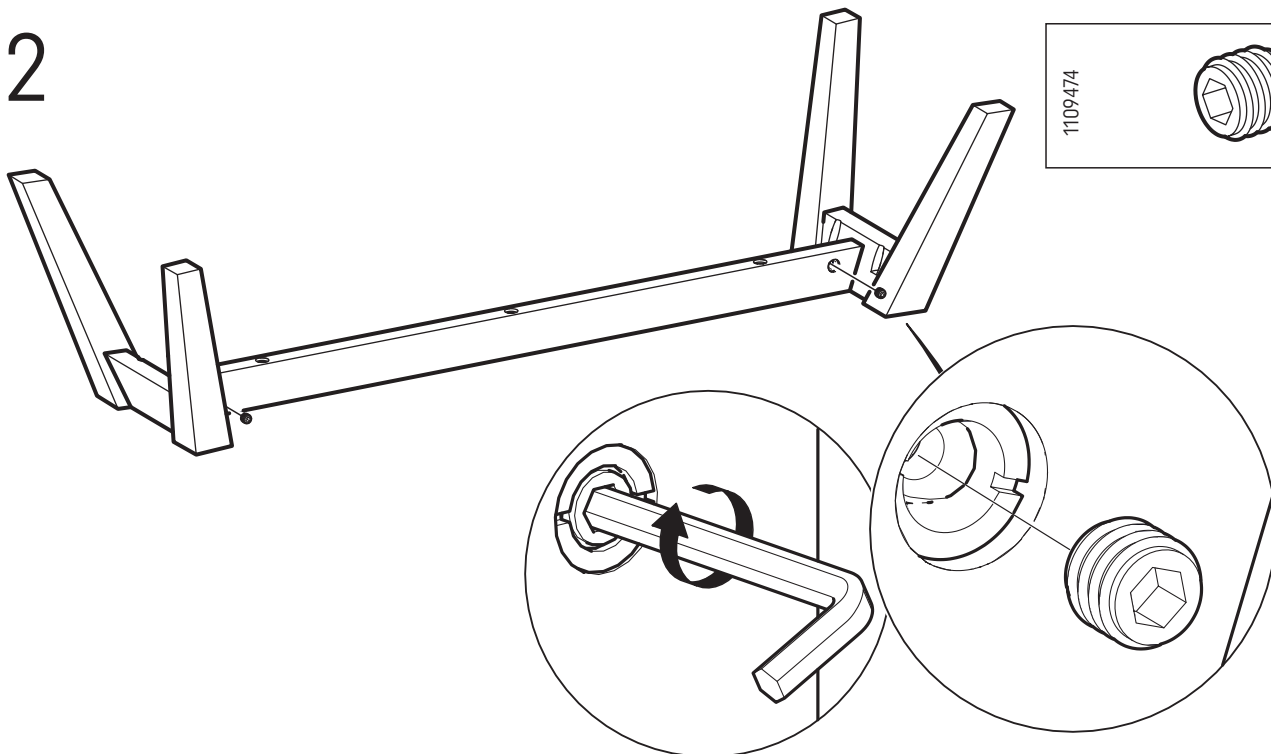
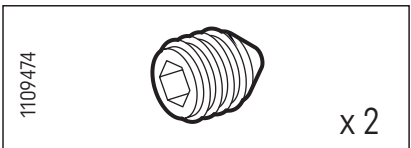

6

13

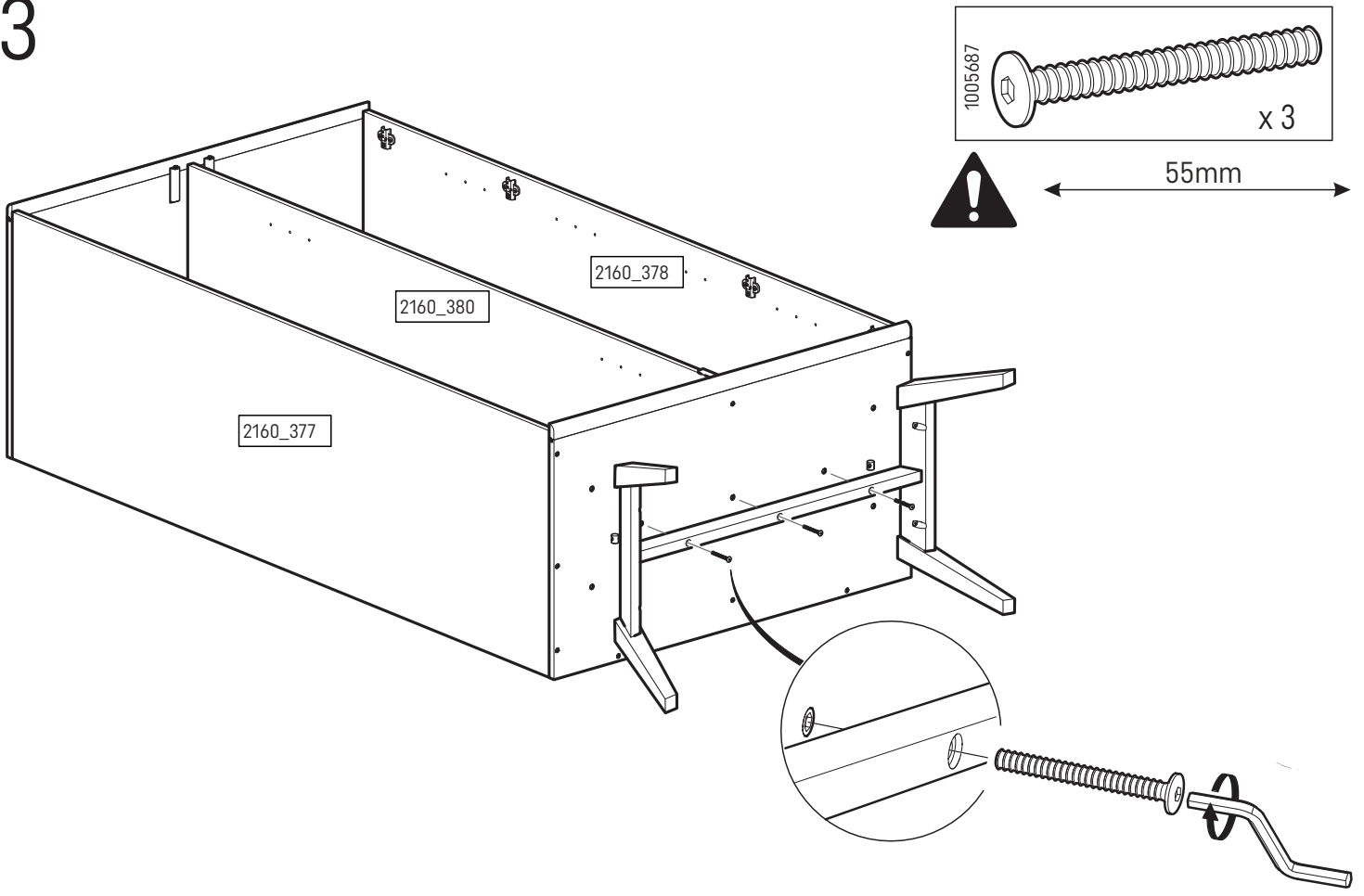

14

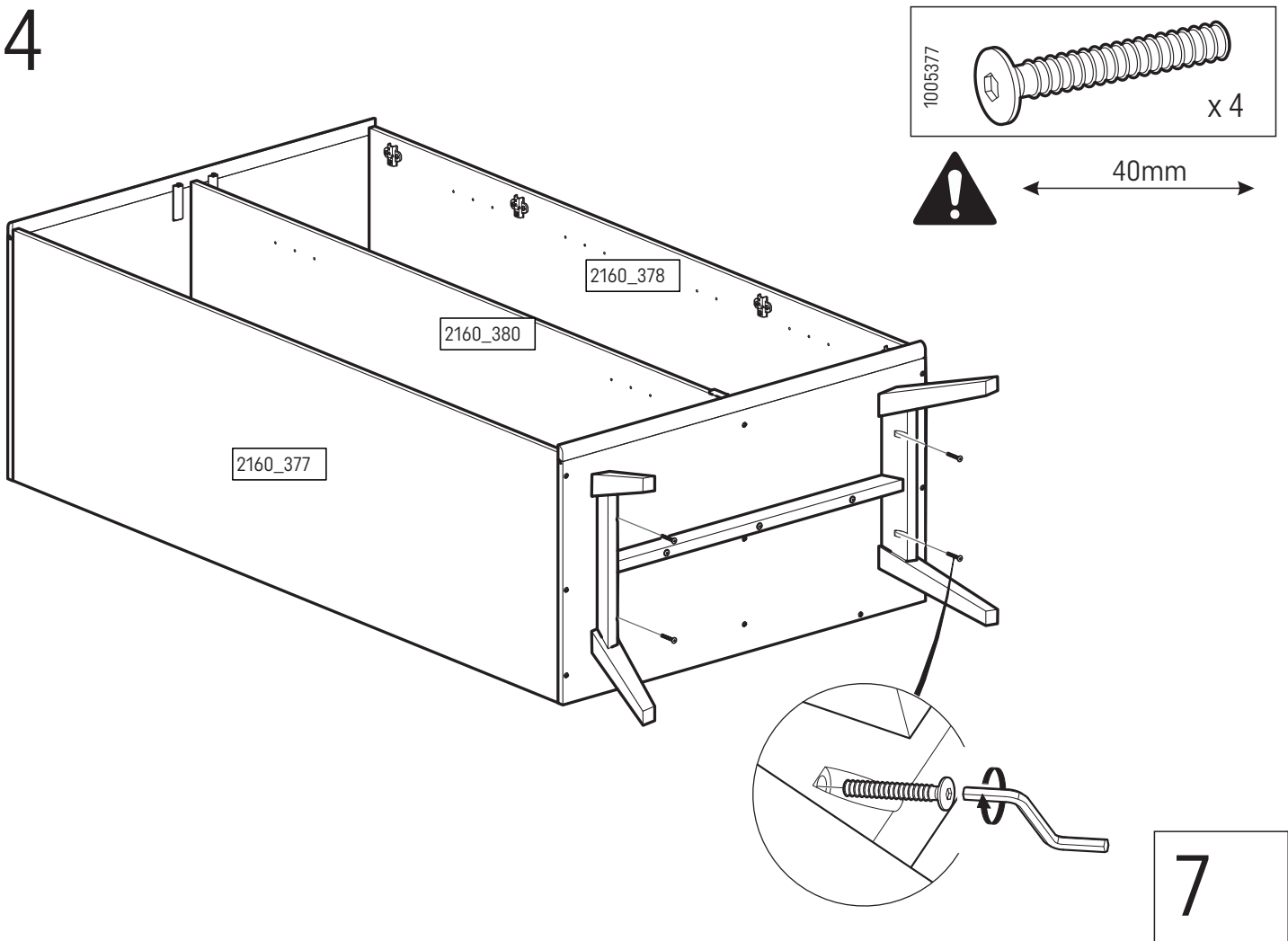

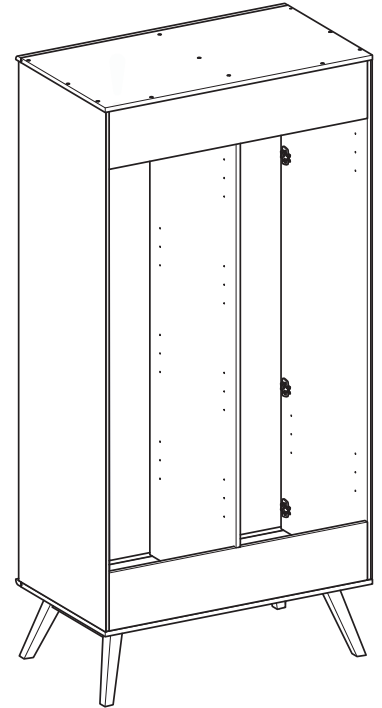
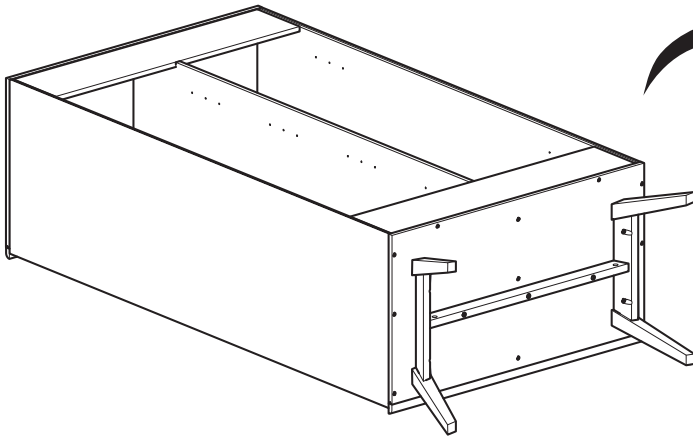
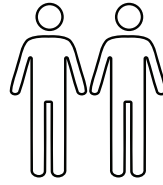

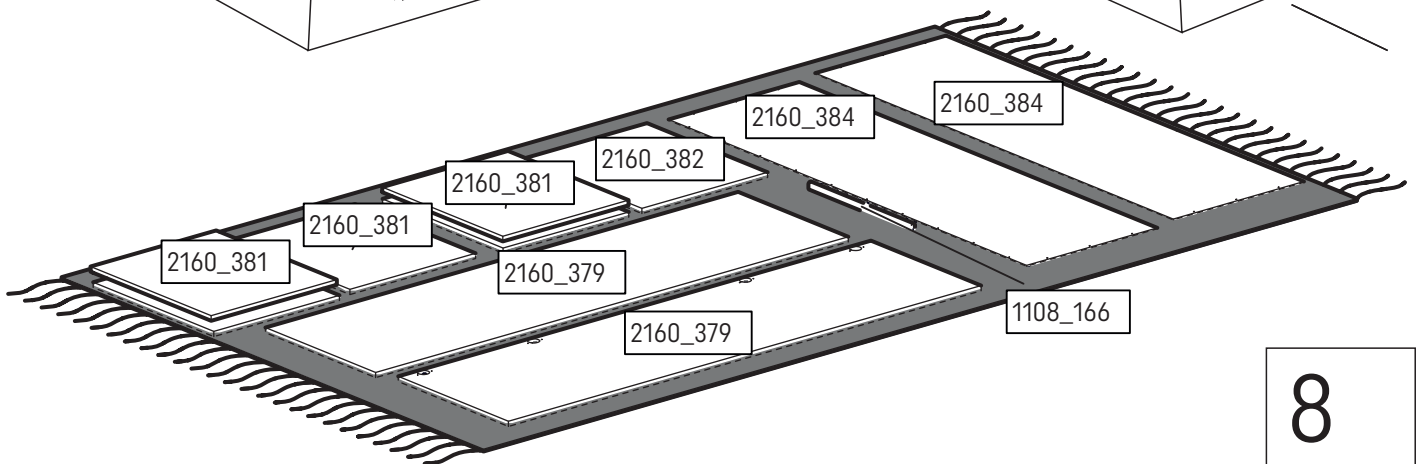
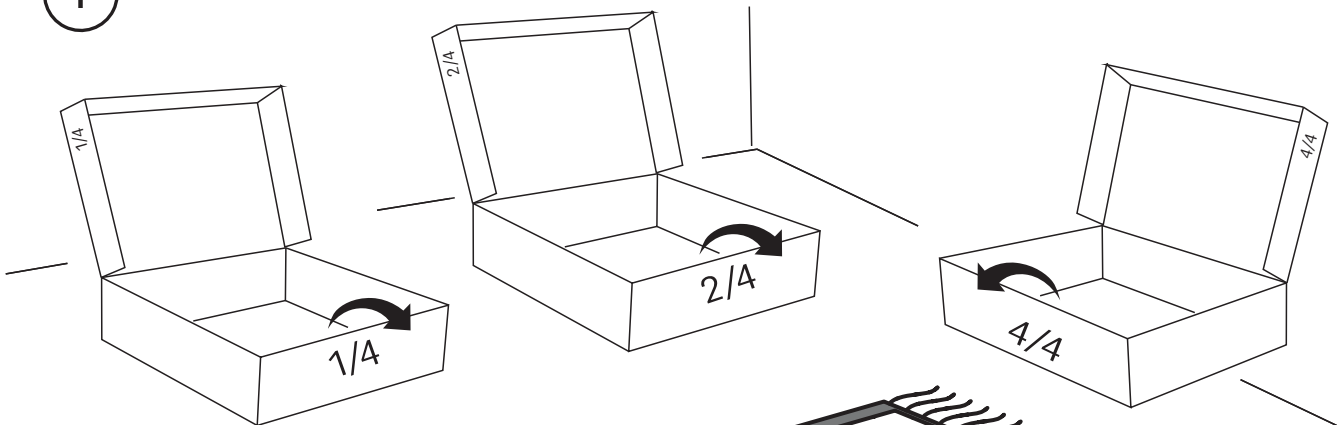

i



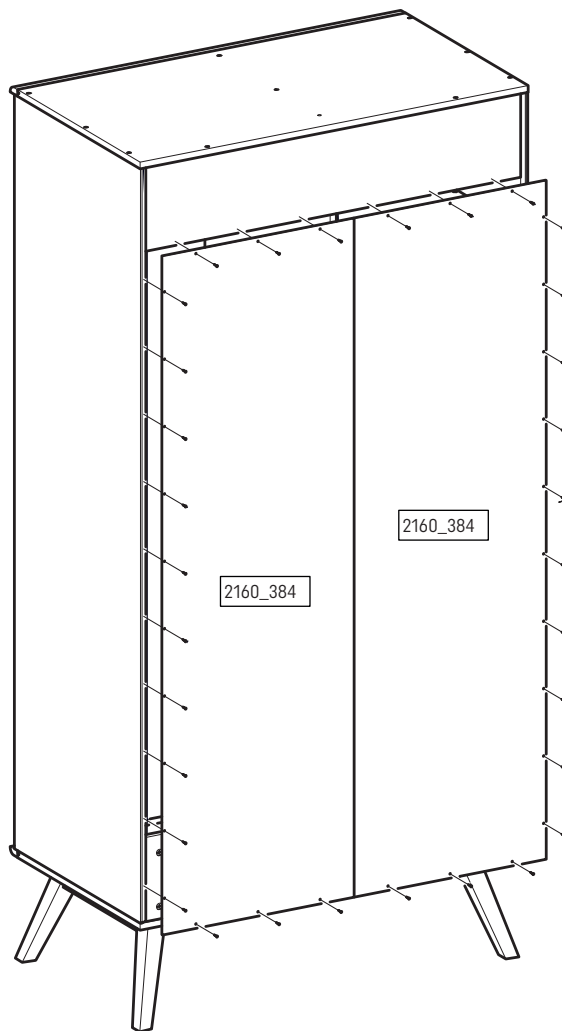

16

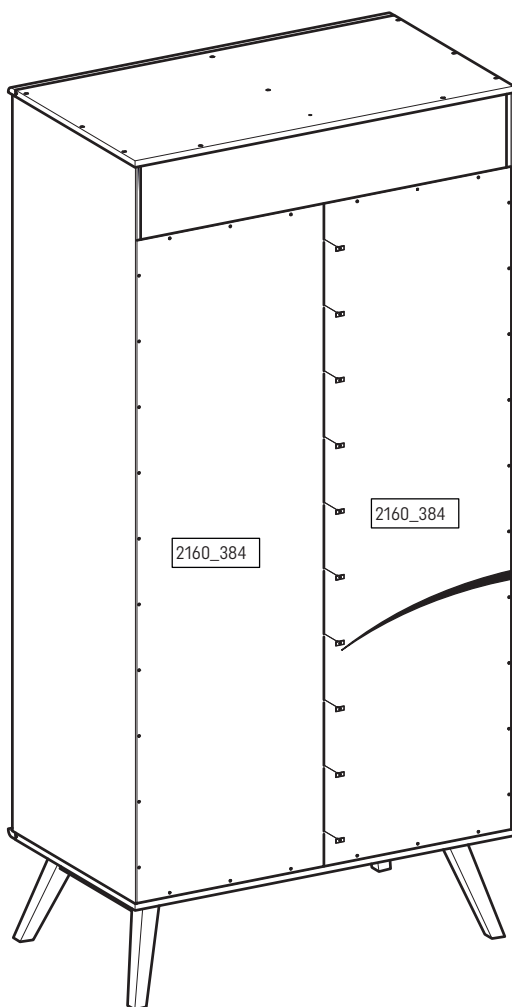

1006012		x 32
---------	---	------

17

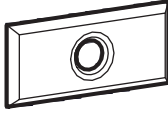

1006012		x 10
1000242		x 10

9

18

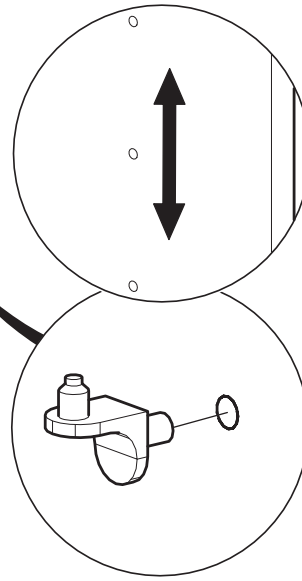
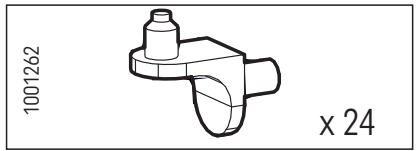
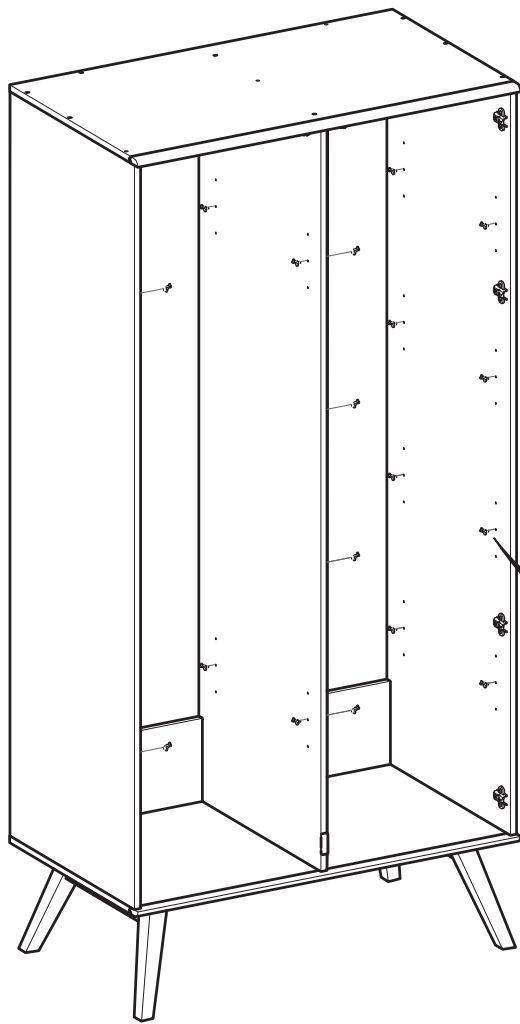

19

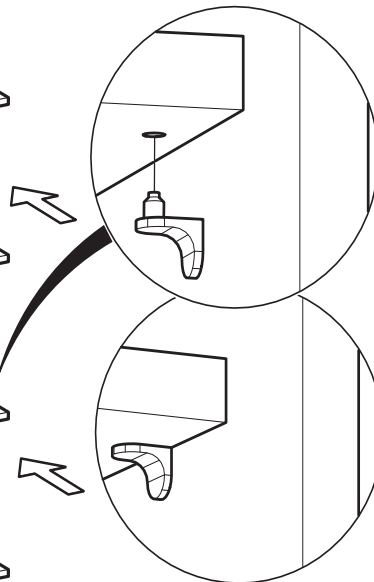
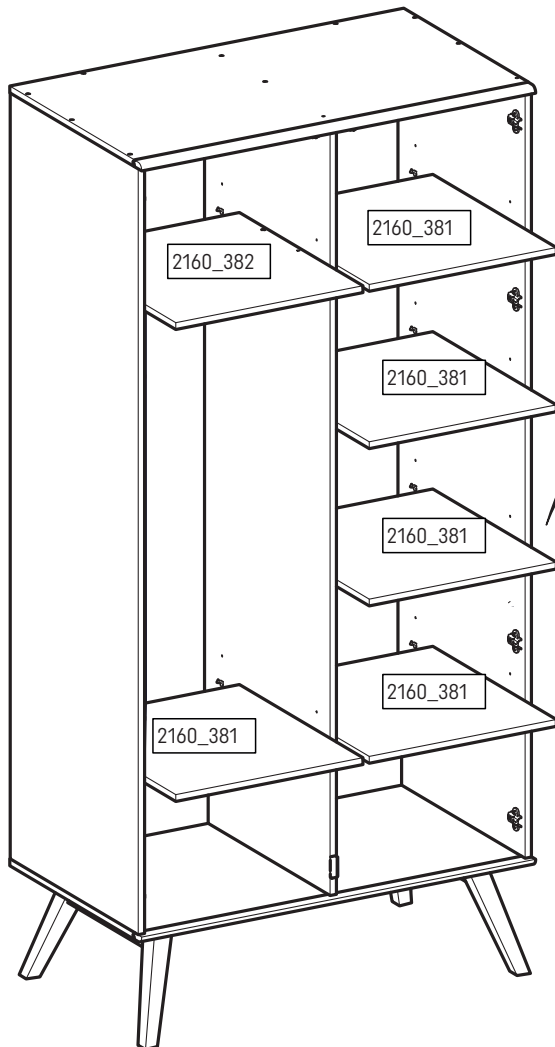

20

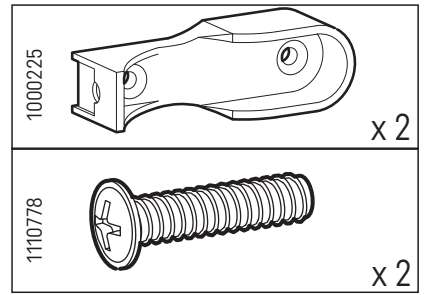
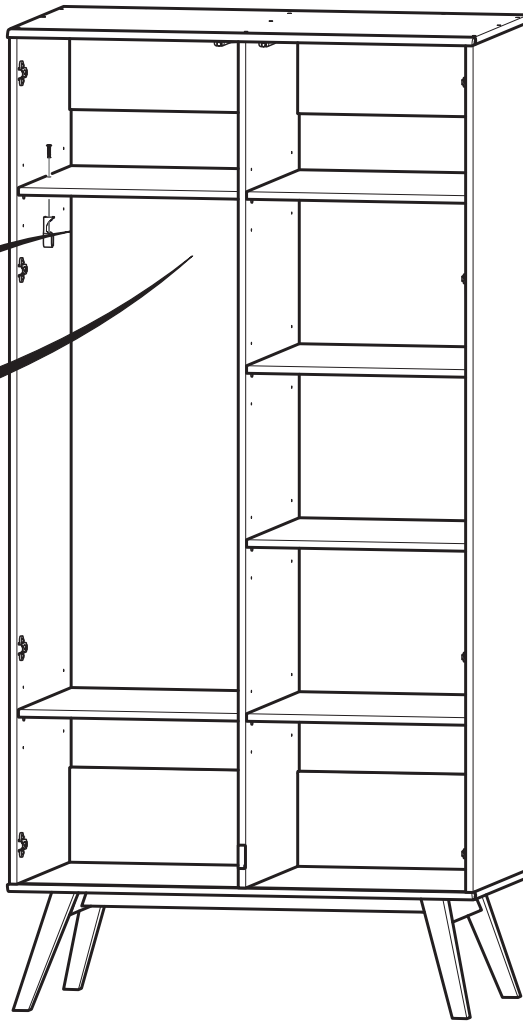
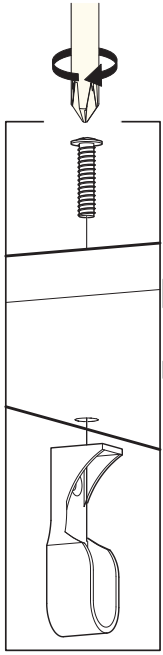

21

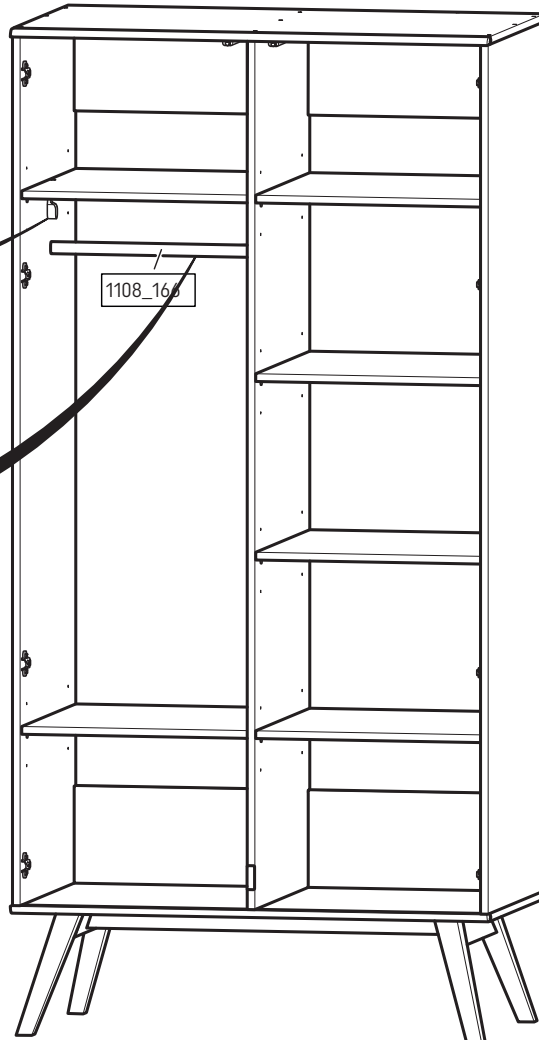
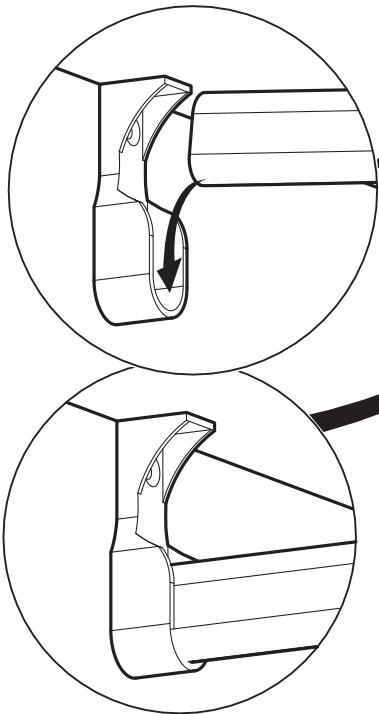

22

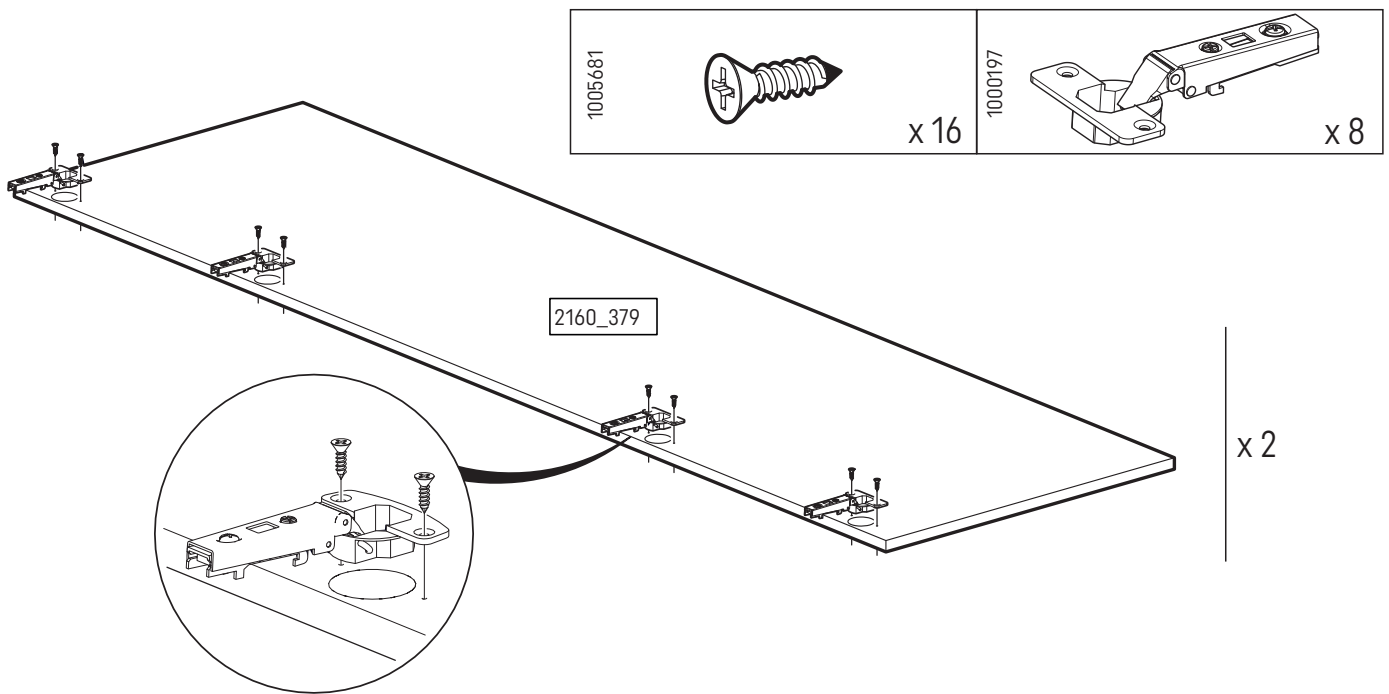

23

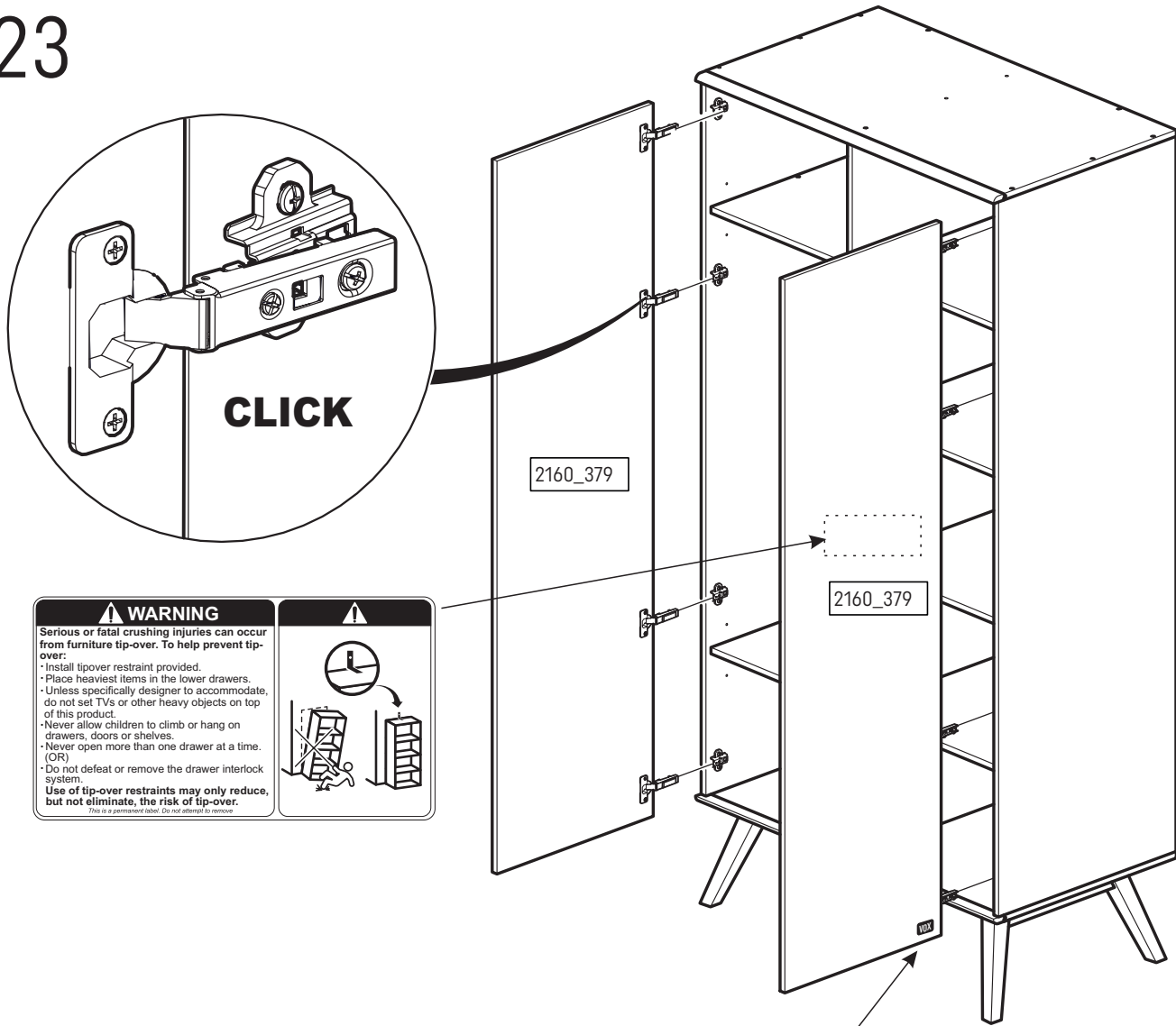

⚠ WARNING
 Serious or fatal crushing injuries can occur from furniture tip-over. To help prevent tip-over:

- Install tipover restraint provided.
- Place heaviest items in the lower drawers.
- Unless specifically designed to accommodate, do not set TVs or other heavy objects on top of this product.
- Never allow children to climb or hang on drawers, doors or shelves.
- Never open more than one drawer at a time. (OR)
- Do not defeat or remove the drawer interlock system.

Use of tip-over restraints may only reduce, but not eliminate, the risk of tip-over.
This is a permanent label. Do not attempt to remove.



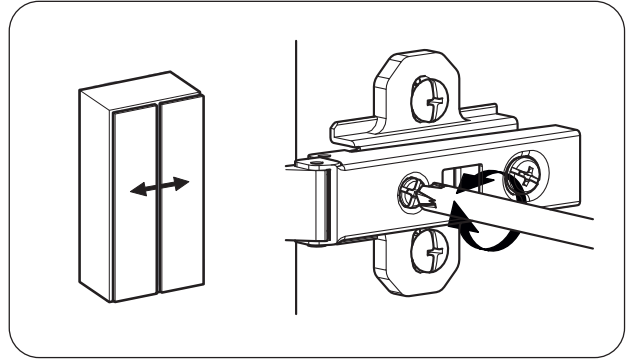
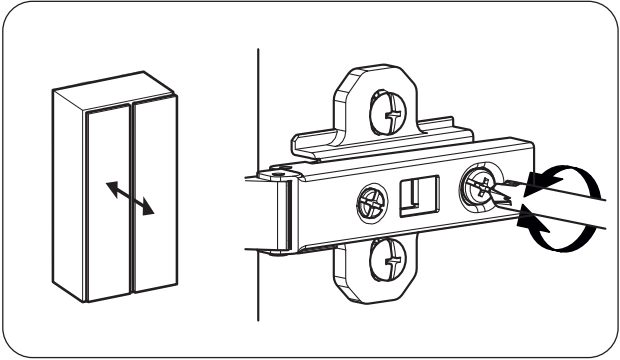
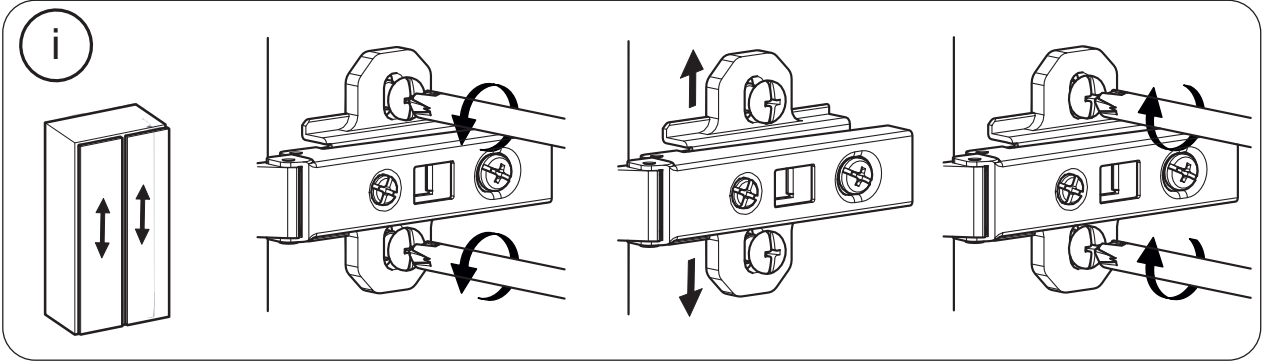

24

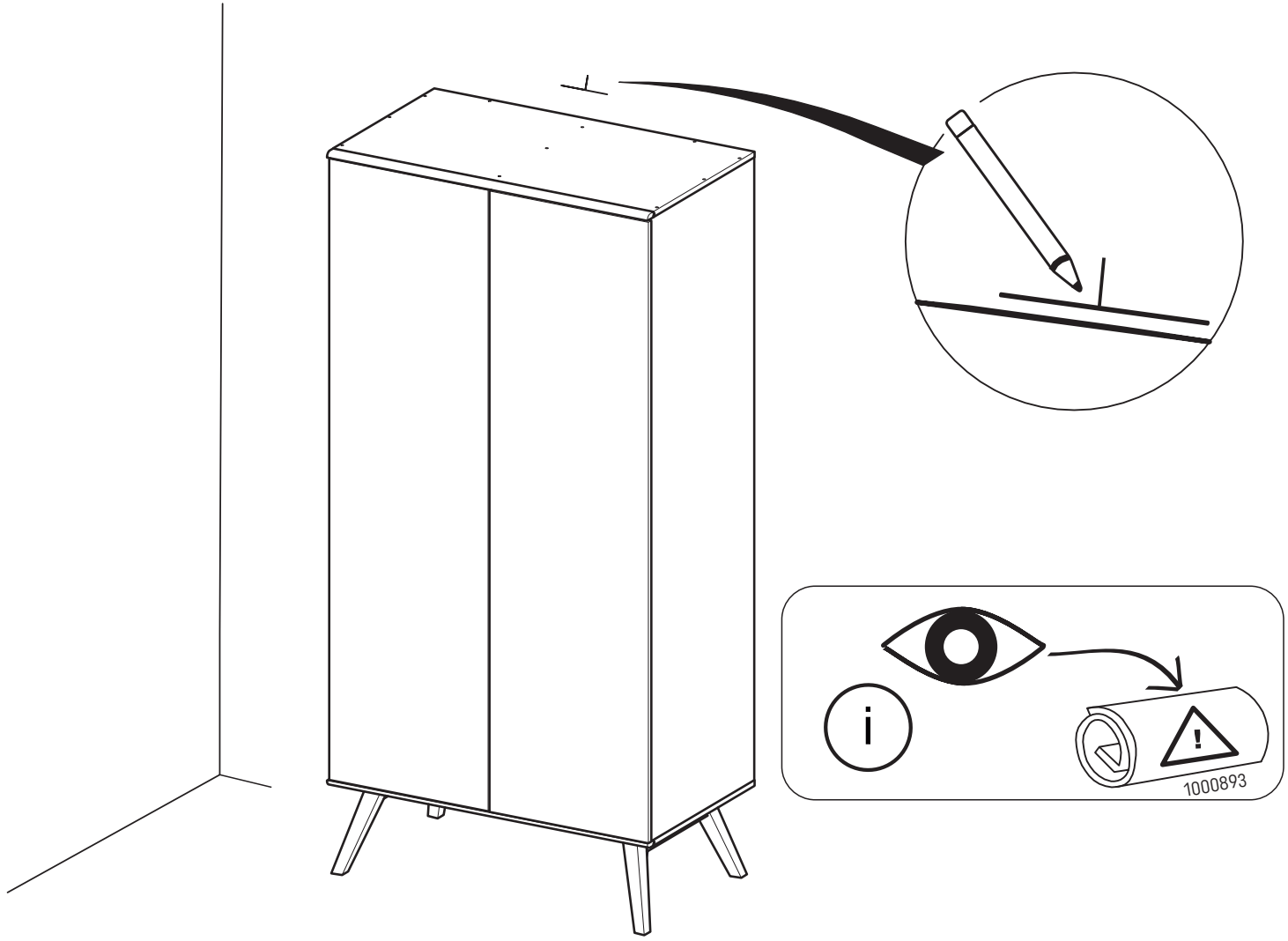

25

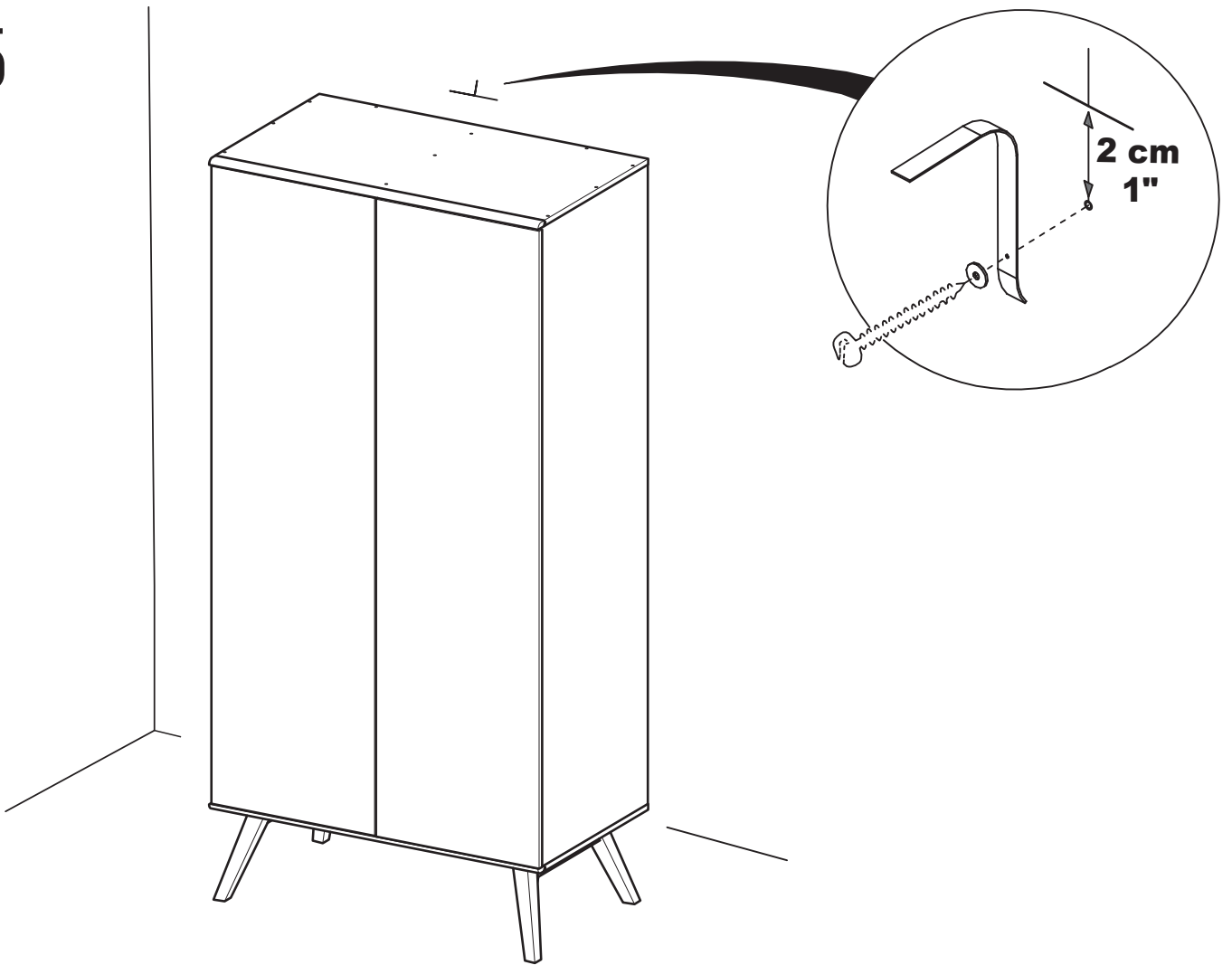

26

