

SAND GRANITE & CHARCOAL : GRANITE SABLE ET CHARBON : *GRANITO ARENA Y CARBON*

TUSCANY BROWN &BLACK: BRUN TOSCANE ET NOIR : *PARDO TOSCANA Y NEGRO*

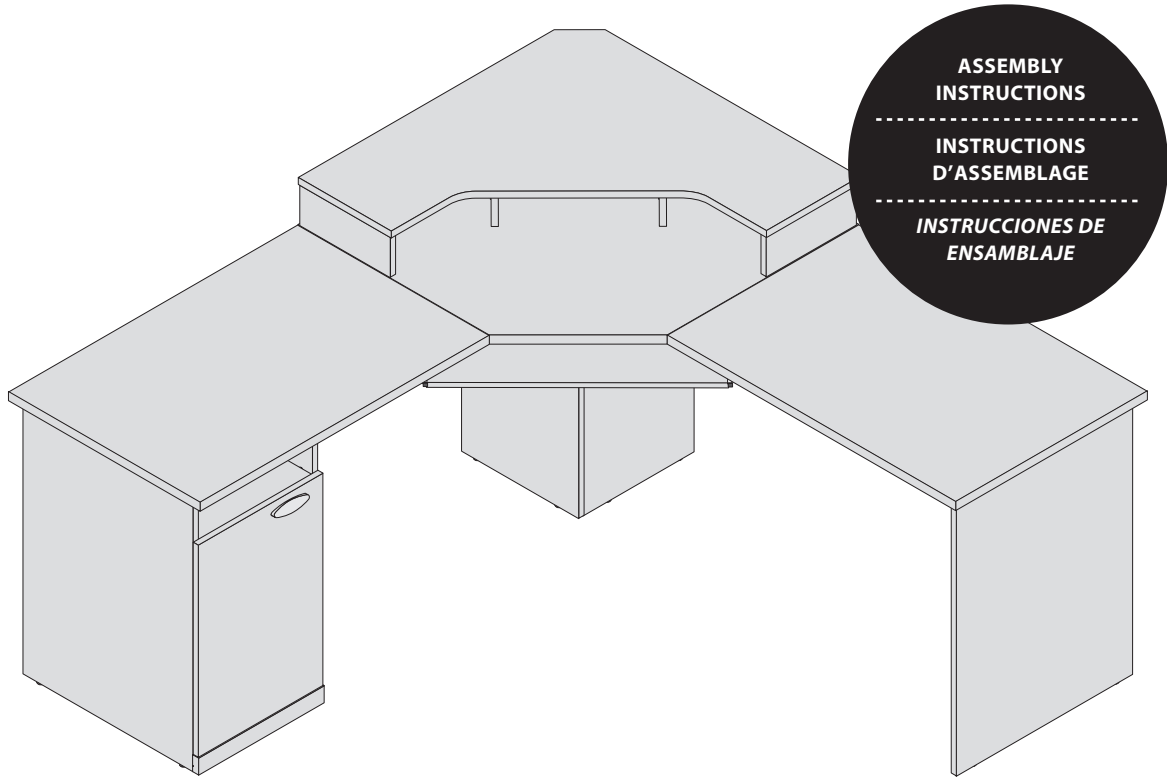

**ASSEMBLY
INSTRUCTIONS**

**INSTRUCTIONS
D'ASSEMBLAGE**

**INSTRUCCIONES DE
ENSAMBLAJE**

**Thank you for choosing our product.
Your total satisfaction is our #1 priority.**

Customer Service and warranty information









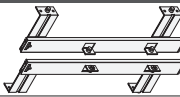
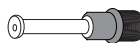

Should you have a problem or need more information concerning the warranty, ***do not call to the place of purchase.***
Please call our customer service department for immediate assistance using the toll free number

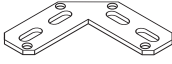
Please have your assembly instruction manual on hand when you call. Our products are warranted to the original purchaser against defects in material or workmanship in the furniture. Defects as mentioned in this warranty refer to any imperfections which may impair the use of the product. Our warranty is expressly limited to the replacement of furniture parts and components for ten years following the date of purchase. We will replace any part that is defective. This warranty applies under conditions of normal use. Our furniture products are not intended for outdoor use. The warranty does not cover defects caused by improper assembly or disassembly, defects occurring after purchase due to product modifications, intentional damage, accident, misuse, exposure to the elements and labor or assembly costs. We reserve the right to request proof of purchase to document a warranty claim. In no event shall we be liable for incidental or consequent damages resulting from the misuse of the product. This warranty is not transferable and is valid only in Canada and the United States excluding Alaska, Hawaii and Puerto Rico.

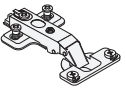
► PARTS / PIÈCES / PIEZAS

CODE / CÓDIGO	QTY / QTÉ / CANT.	CODE / CÓDIGO	QTY / QTÉ / CANT.	CODE / CÓDIGO	QTY / QTÉ / CANT.	CODE / CÓDIGO	QTY / QTÉ / CANT.
30	1	36	1	43	1	73	2
31	1	37	1	44	1	74	1
32	1	38	1	46	1	75	1
33	1	40	1	60	1	80	1
34	1	41	1	70	1		
35	1	42	1	71	1		
						back panel / dos / panel trasero 14 5/8" x 23 5/16" (372 mm x 592 mm)	1

► HARDWARE / QUINCAILLERIES / QUINCALLA

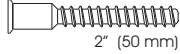
CODE / CÓDIGO	QTY / QTÉ / CANT.	CODE / CÓDIGO	QTY / QTÉ / CANT.	CODE / CÓDIGO	QTY / QTÉ / CANT.	CODE / CÓDIGO	QTY / QTÉ / CANT.
AM-182 	1	CO-843 	1	H-36 	39	VF-231 	2
CA-99 	12	EQ-143 	4	PA-844 	10	VR-207 	7
CH-838 	2	EQ-314 	2	PO-831 	1	VR-210 	16
CL-140 	-	H-03 	39	VC-204 	10		

► REAL SIZE / GRANDEUR RÉELLE / TAMAÑO REAL

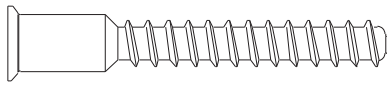
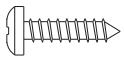
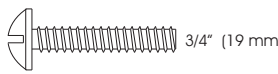
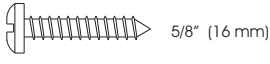
CODE / CÓDIGO	QTY / QTÉ / CANT.	CODE / CÓDIGO	QTY / QTÉ / CANT.
VC-204 	10	VR-207 	7
VF-231 	2	VR-210 	16

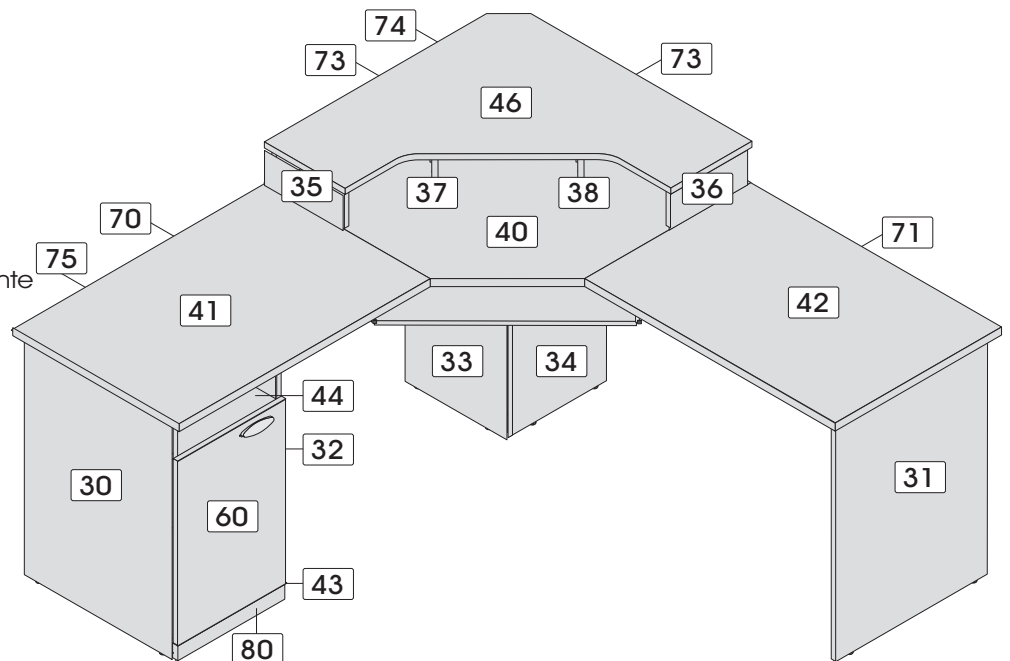

► Important notice / Note importante
Nota importante

Group together all the hardware required for each step as the construction of your piece of furniture is progressing.

Regroupez toutes les quincailleries requises pour chaque étape de façon à vous assurer de tout installer au bon moment.

Reúna todas las quincallas necesarias para cada una de las etapas de montaje, para asegurar una correcta instalación en el momento adecuado.

▶ IMPORTANT NOTICE / NOTE IMPORTANTE / NOTA IMPORTANTE

Duly complete the self-adhesive sticker. / Assurez-vous de bien remplir l'autocollant. / Asegúrese de completar correctamente la etiqueta.



two people are required to assemble and move this model.
deux personnes sont requises pour assembler et déplacer ce modèle.
se necesitan dos personas para ensamblar y desplazar este mueble.



the use of electric tools must be made with vigilance.
l'utilisation d'outils électriques doit être faite avec vigilance.
las herramientas eléctricas deben utilizarse con sumo cuidado.

tools required
outils requis
herramientas necesarias



1/4" (7 mm)

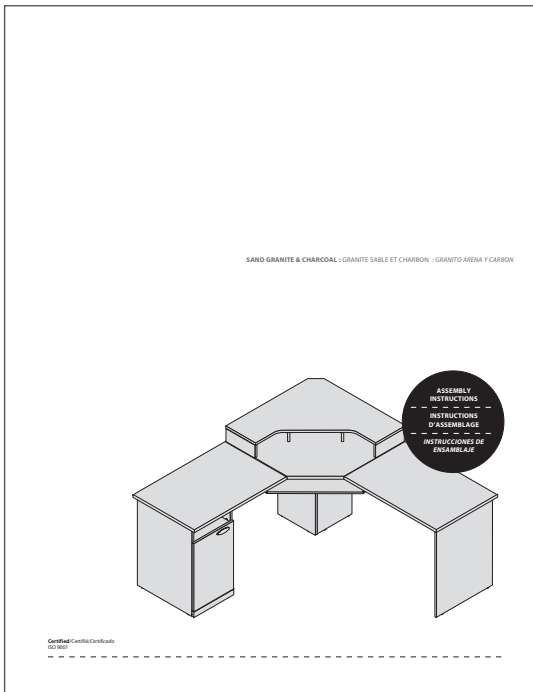

To better serve you!
Pour mieux vous servir!

Model / Modèle: _____

Production Number
Numéro de production: _____

Customer Service
Service à la clientèle

Important/Importante

Please retain the self-adhesive sticker which you will find at step 14 of the instruction manual.
Conservez l'autocollant qui sera collé seulement à l'étape 14 du feuillet d'instructions.
Conserve la etiqueta que será pegada sólo en la etapa 14 de la hoja de instrucciones.

▶ IMPORTANT NOTICE / NOTE IMPORTANTE / NOTA IMPORTANTE

Main hardware system / Système de quincaillerie principal / Sistema principal de quincalla

1
H-36

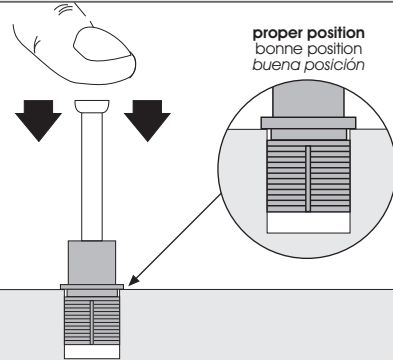

proper position
bonne position
buena posición

2
H-03

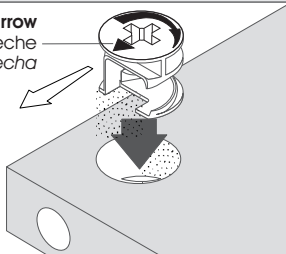

arrow
flèche
flecha

Insert the cam with the arrow pointing towards the hole in the edge.
Insérez la rondelle en pointant la flèche vers le trou de la bordure.
Inserte la arandela apuntando la flecha hacia el orificio cercano el borde.

If needed / En cas de nécessité
En caso de necesidad

How to remove a misplaced assembly bolt (H-36).
Comment retirer un boulon (H-36) mal situé.
Cómo retirar un perno (H-36) mal ubicado.

A

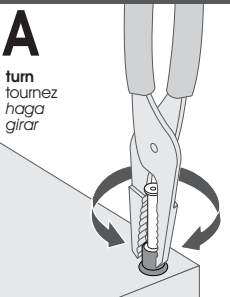

turn
tournez
haga girar

B

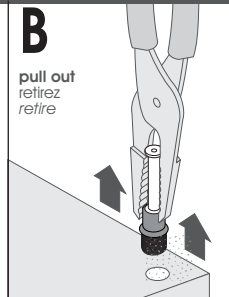

pull out
retirez
retire

1 **HARDWARE INSTALLATION / INSTALLATION DES QUINCAILLERIES / INSTALACIÓN DE LAS QUINCALLAS**

Desk / Bureau / Escritorio

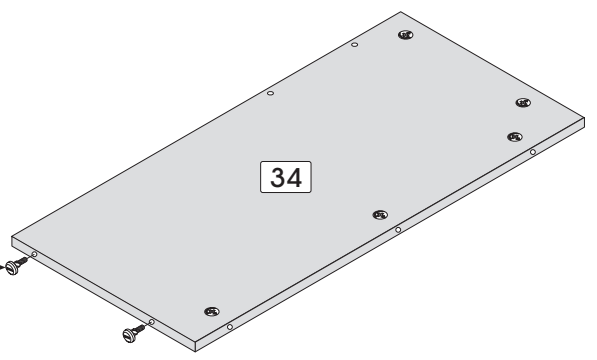
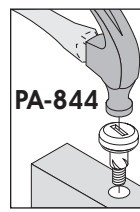
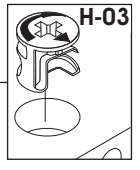
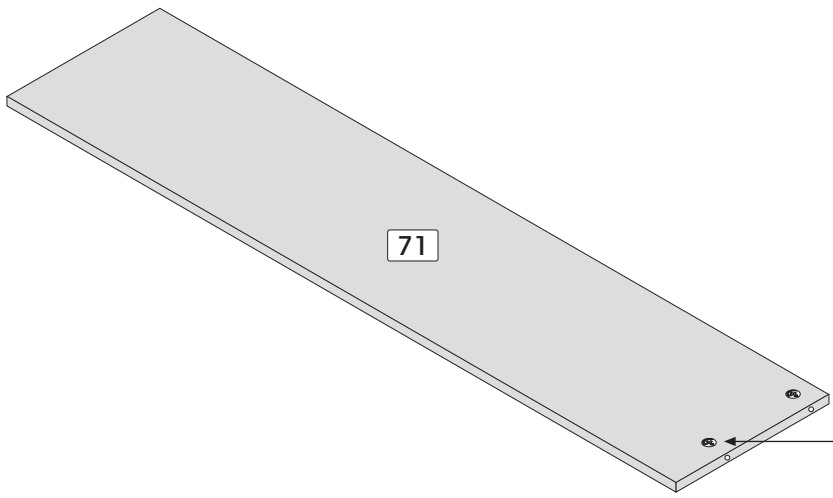
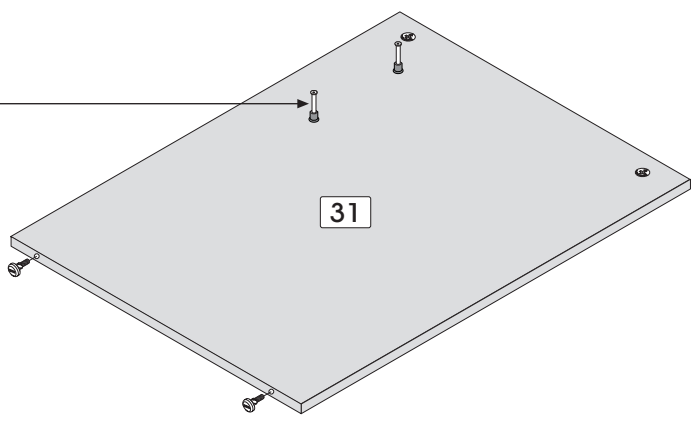
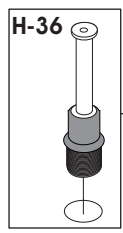

1

Code / Código

Qty / Qté / Cant.



H-03

x 9

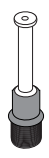

H-36

x 2



PA-844

x 4

IMPORTANT NOTICE / NOTE IMPORTANTE / NOTA IMPORTANTE

▶ **Main hardware system / Système de quincaillerie principal / Sistema principal de quincalla**

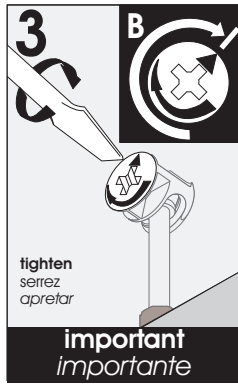
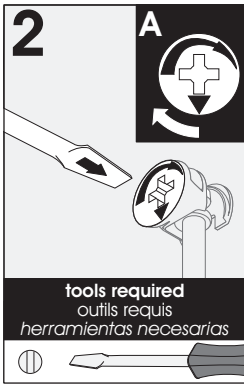
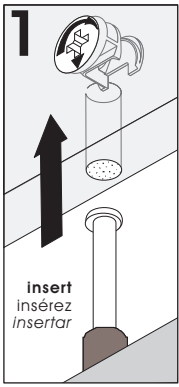

Make sure to properly tighten each cam to ensure furniture solidity. Otherwise, parts could be damaged or the user could be injured.

Assurez-vous de bien resserrer chaque rondelle pour assurer la solidité du meuble. Dans le cas contraire, des pièces pourraient être endommagées ou l'utilisateur pourrait se blesser.

Asegúrese de apretar bien cada arandela para garantizar la solidez del mueble. De lo contrario, podría provocarse daño a las piezas o las personas.

2 PRE-ASSEMBLY / PRÉ-ASSEMBLAGE / PREENSAMBLAJE

Desk / Bureau / Escritorio

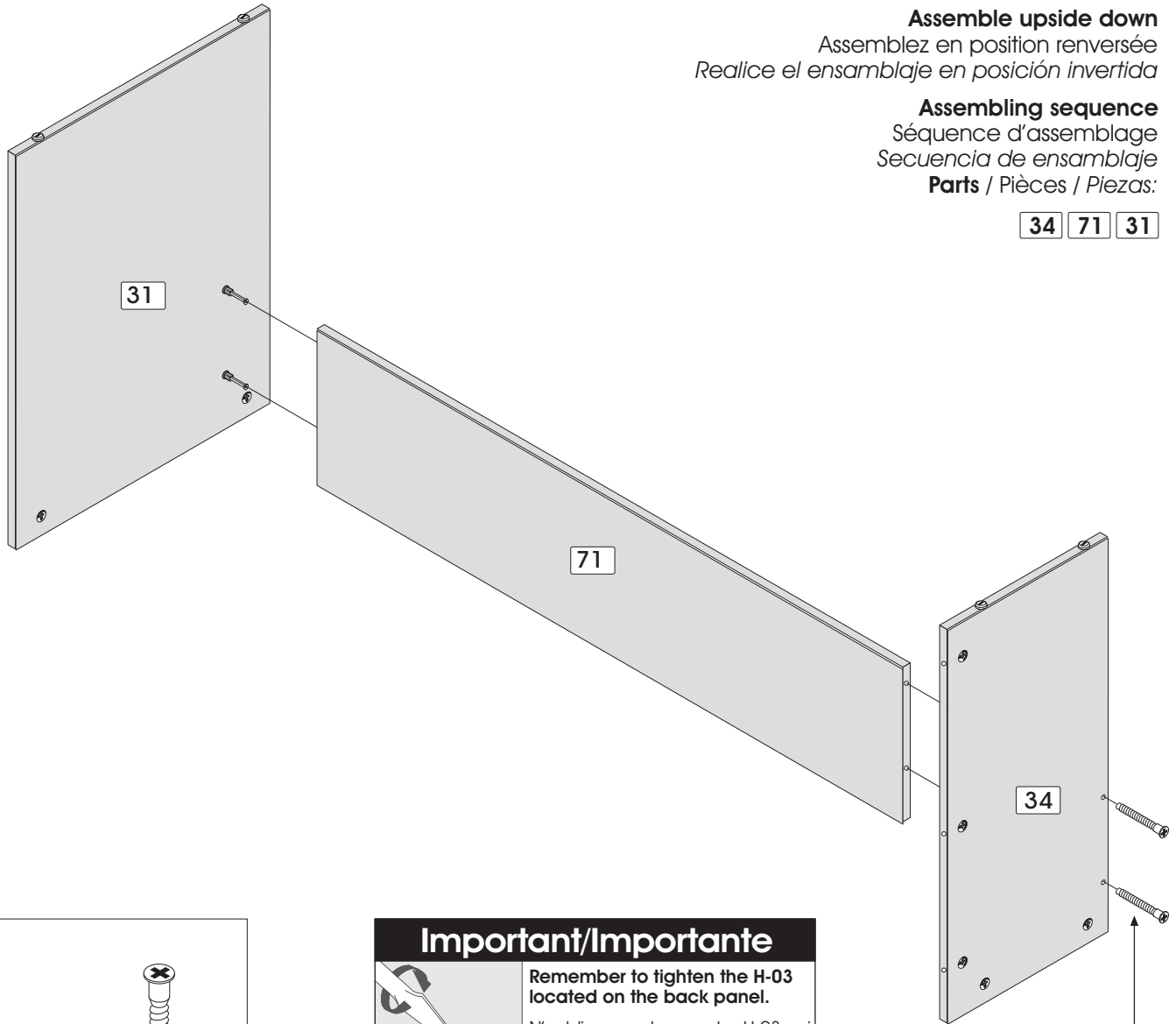

Assemble upside down

Assemblez en position renversée

Realice el ensamblaje en posición invertida

Assembling sequence

Séquence d'assemblage

Secuencia de ensamblaje

Parts / Pièces / Piezas:

34 71 31

2

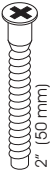

Code / Código VC-204
Qty / Qté / Cant. x 2

Important/Importante

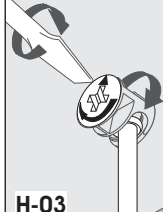

H-03

Remember to tighten the H-03 located on the back panel.
N'oubliez pas de serrer les H-03 qui sont situées au dos.
No se olvide de apretar las H-03 que se encuentran en el panel trasero.

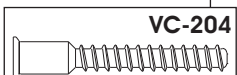

VC-204

3 HARDWARE INSTALLATION / INSTALLATION DES QUINCAILLERIES / INSTALACIÓN DE LAS QUINCALLAS

Desk / Bureau / Escritorio

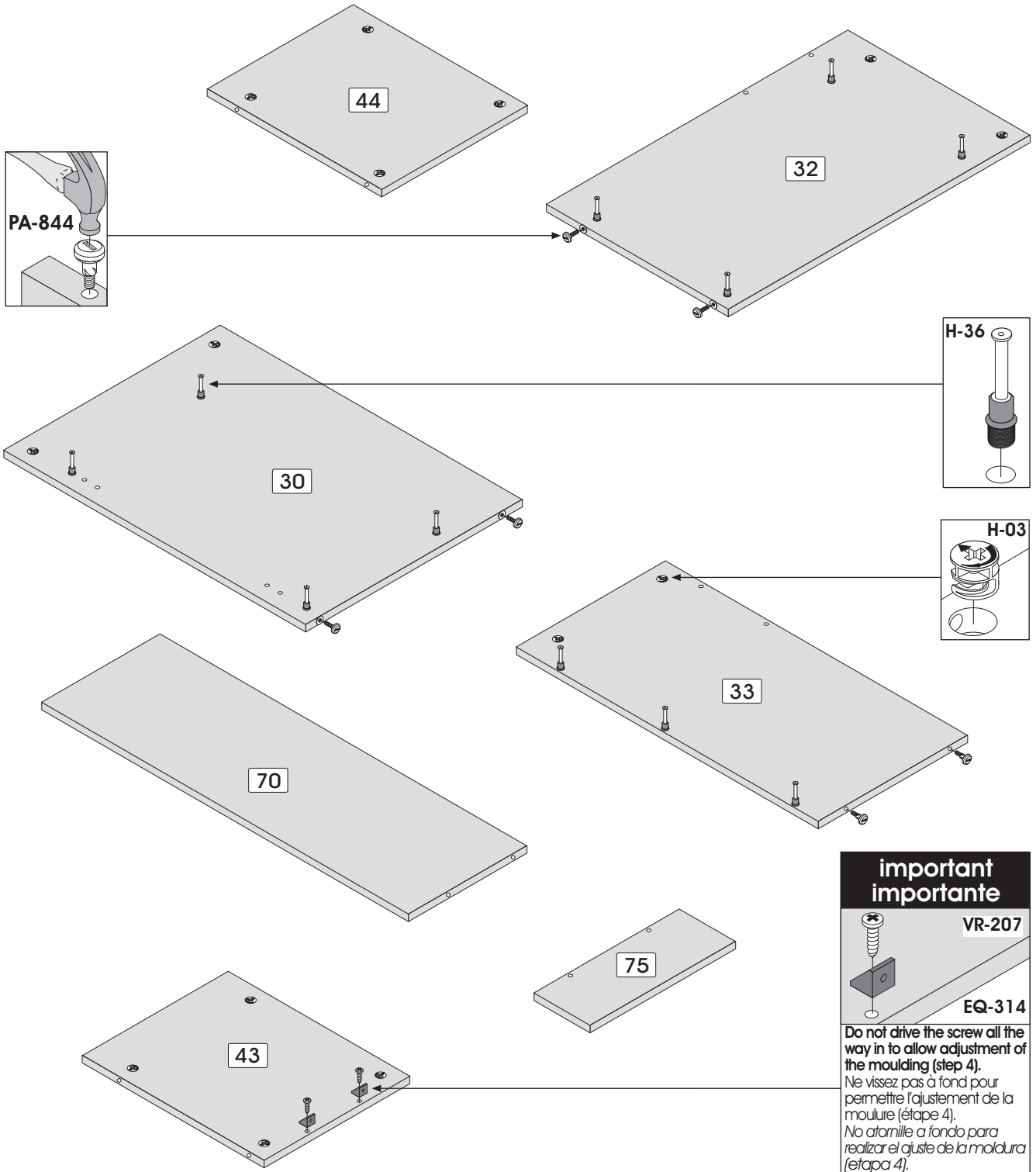

important
importante

VR-207

EQ-314

Do not drive the screw all the way in to allow adjustment of the moulding (step 4).
Ne vissez pas à fond pour permettre l'ajustement de la moulure (étape 4).
No atornille a fondo para realizar el ajuste de la moldura (etapa 4).

3

Code / Código	H-03	H-36	PA-844	EQ-314	VR-207
Qty / Qté / Cant.	x 14	x 11	x 6	x 2	x 2

Assemble on the side

Assemblez sur le côté

Realice el ensamblaje sobre la parte lateral

Assembling sequence

Séquence d'assemblage

Secuencia de ensamblaje

Parts / Pièces / Piezas:

30 44 43 32 80



two people are required to assemble and move this model.

deux personnes sont requises pour assembler et déplacer ce modèle.

se necesitan dos personas para ensamblar y desplazar este mueble.

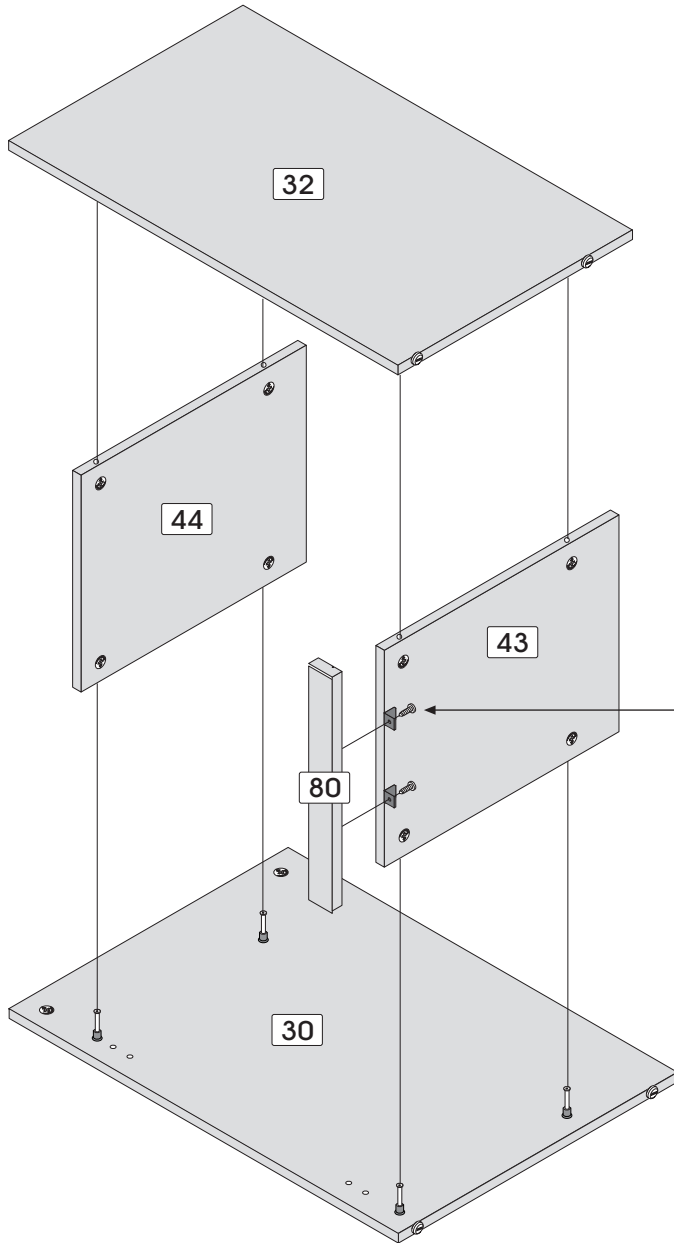

important / importante

ajust the mouldings and tight the screws VR-207

ajuster la moulure et visser les vis VR-207

ajustar la moldura y apretar los tornillos VR-207

Important/Importante

Remember to tighten the H-03 located on the back panel.

N'oubliez pas de serrer les H-03 qui sont situées au dos.

No se olvide de apretar las H-03 que se encuentran en el panel trasero.

H-03

4	
	1/2" (13 mm)
Code / Código	VR-207
Qty / Qté / Cant.	x 2

Desk / Bureau / Escritorio



two people are required to assemble and move this model.

deux personnes sont requises pour assembler et déplacer ce modèle.
se necesitan dos personas para ensamblar y desplazar este mueble.

Assemble upside down

Assemblez en position renversée
Realice el ensamblaje en posición invertida

Assembling sequence

Séquence d'assemblage
Secuencia de ensamblaje

Parts / Pièces / Piezas:

32 44 + **70 33 75**

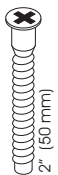
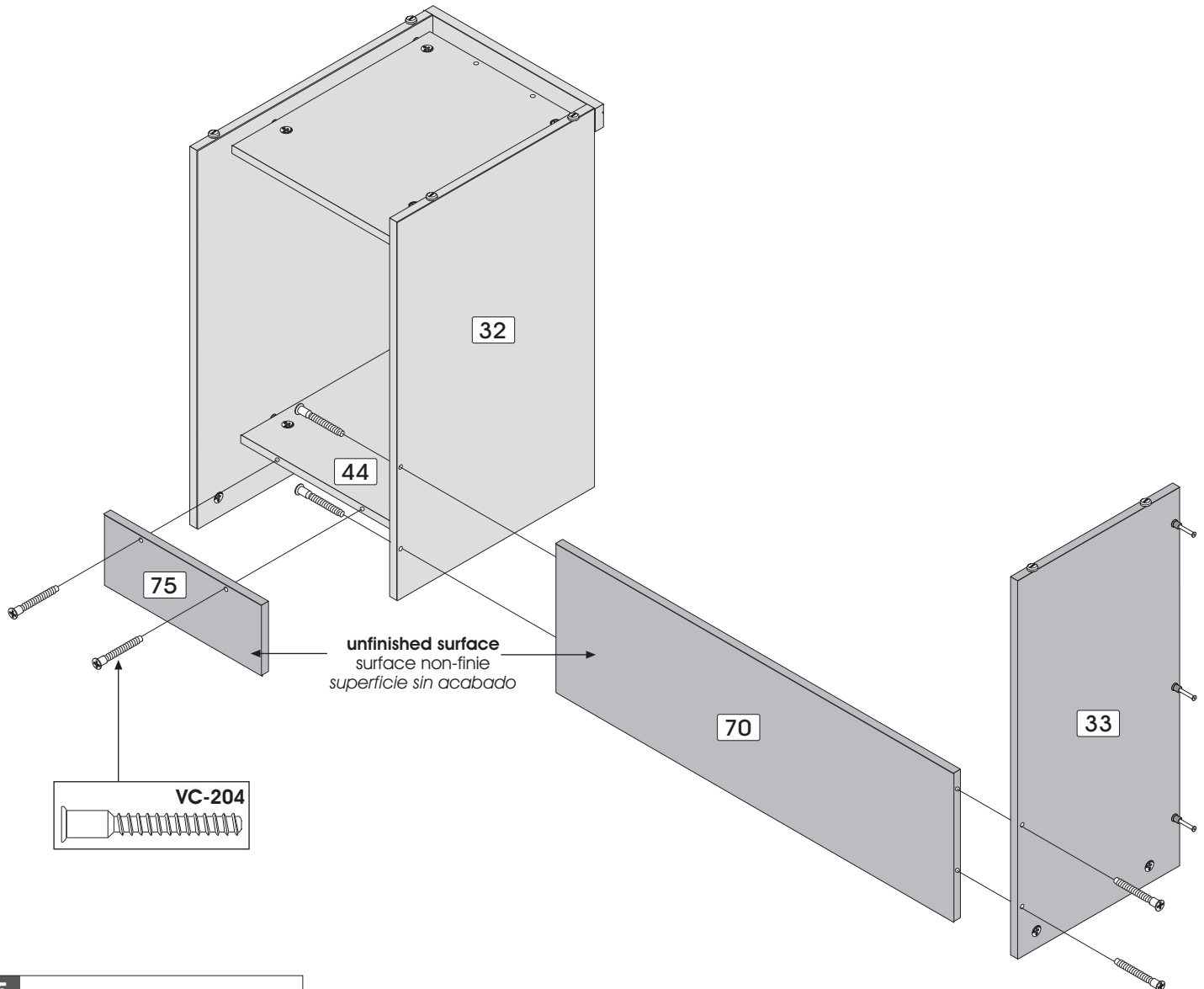

Code / Código VC-204

Qty / Qté / Cant. x 6

6 HARDWARE INSTALLATION / INSTALLATION DES QUINCAILLERIES / INSTALACIÓN DE LAS QUINCALLAS

Desk / Bureau / Escritorio

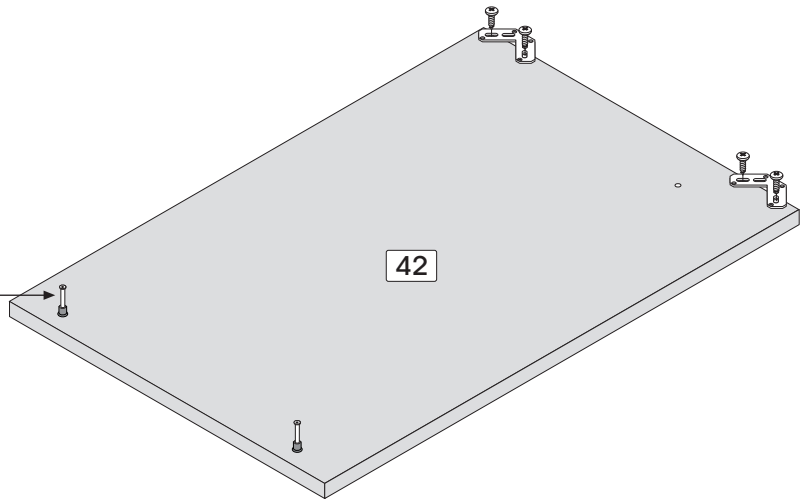
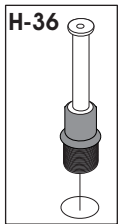
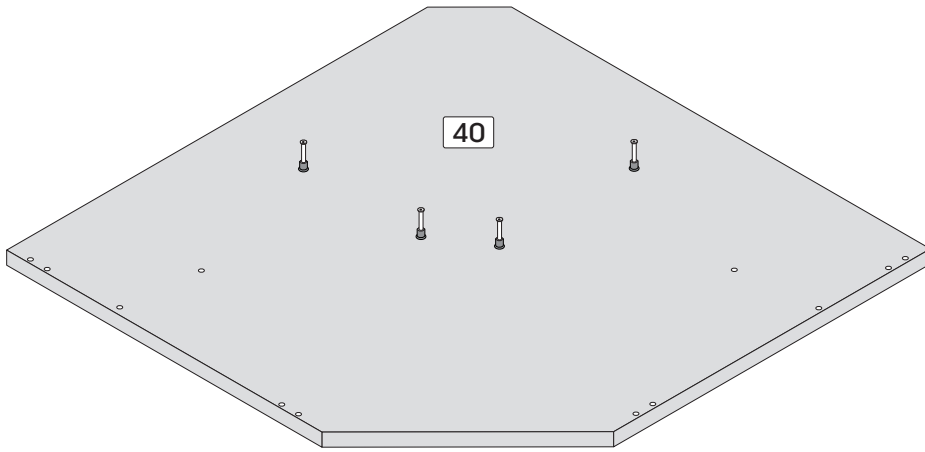
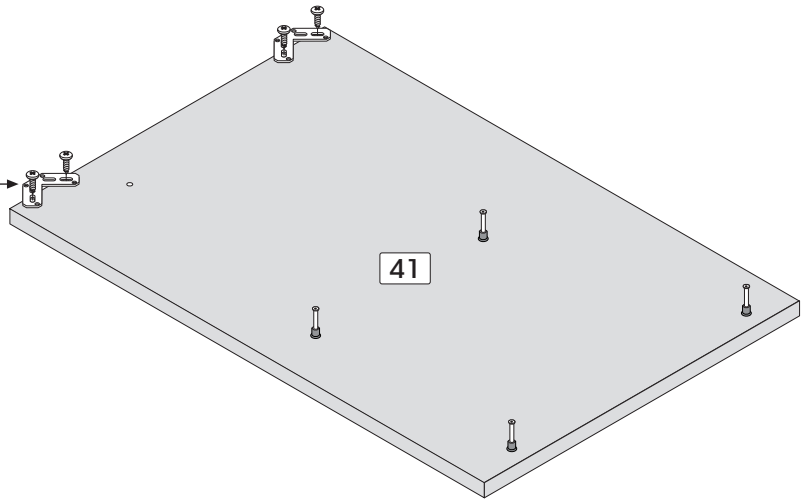
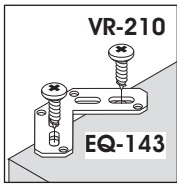

6

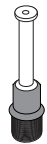

H-36

x 10

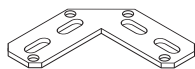

EQ-143

x 4



VR-210

x 8

Code / Código

Qty / Qté / Cant.

Desk / Bureau / Escritorio

Assembling sequence

Séquence d'assemblage

Secuencia de ensamblaje

Parts / Pièces / Piezas:

30 32 33 + **34 31** + **41 42**

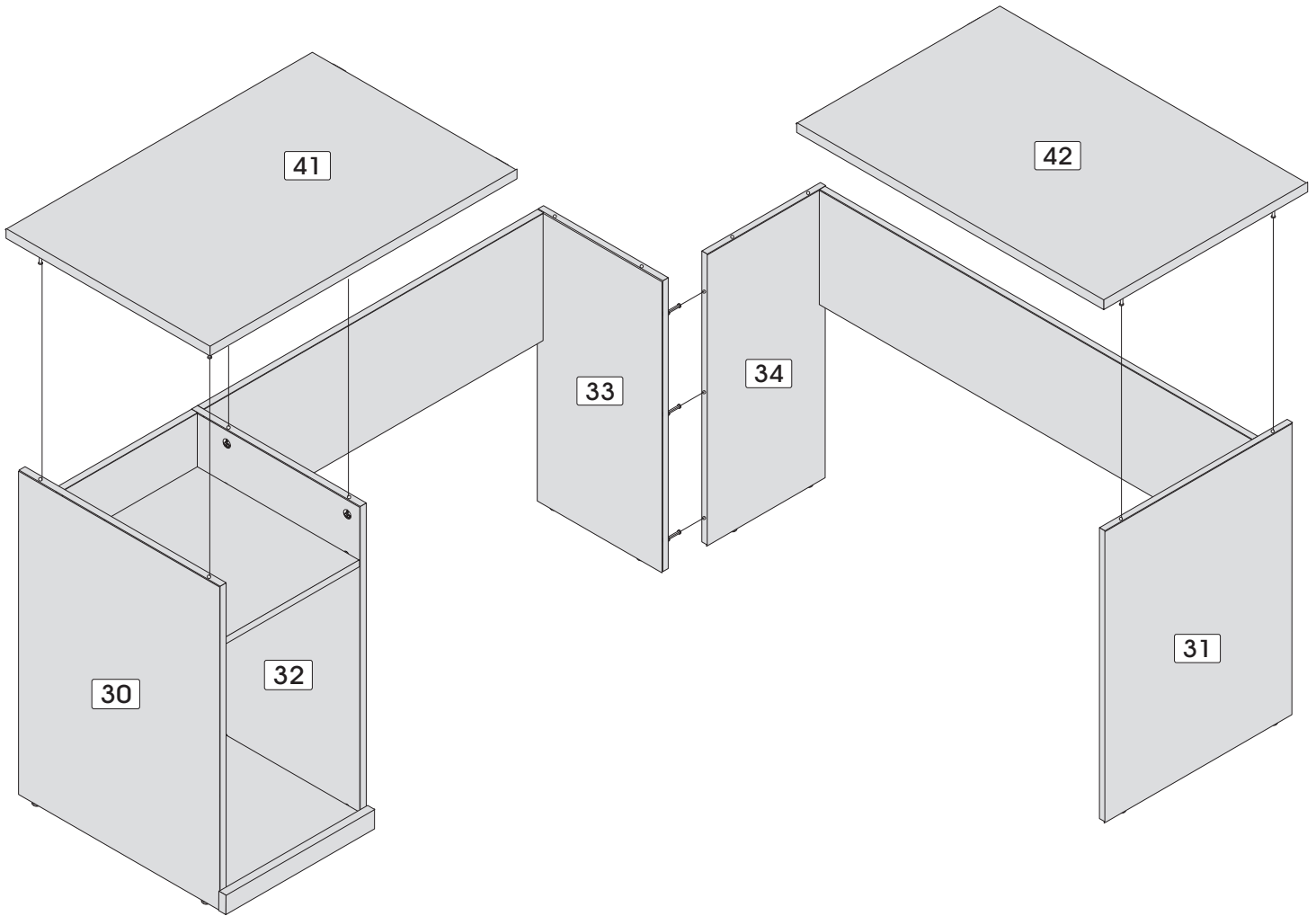

 **two people are required to assemble and move this model.**
 deux personnes sont requises pour assembler et déplacer ce modèle.
 se necesitan dos personas para ensamblar y desplazar este mueble.

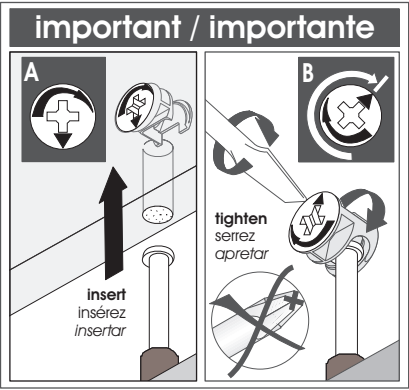

Desk / Bureau / Escritorio

Underneath View

Vue de dessous
Visión de debajo

Assembling sequence

Séquence d'assemblage
Secuencia de ensamblaje

Parts / Pièces / Piezas:

41 42 + 40



two people are required to assemble and move this model.
deux personnes sont requises pour assembler et déplacer ce modèle.
se necesitan dos personas para ensamblar y desplazar este mueble.

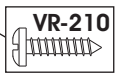
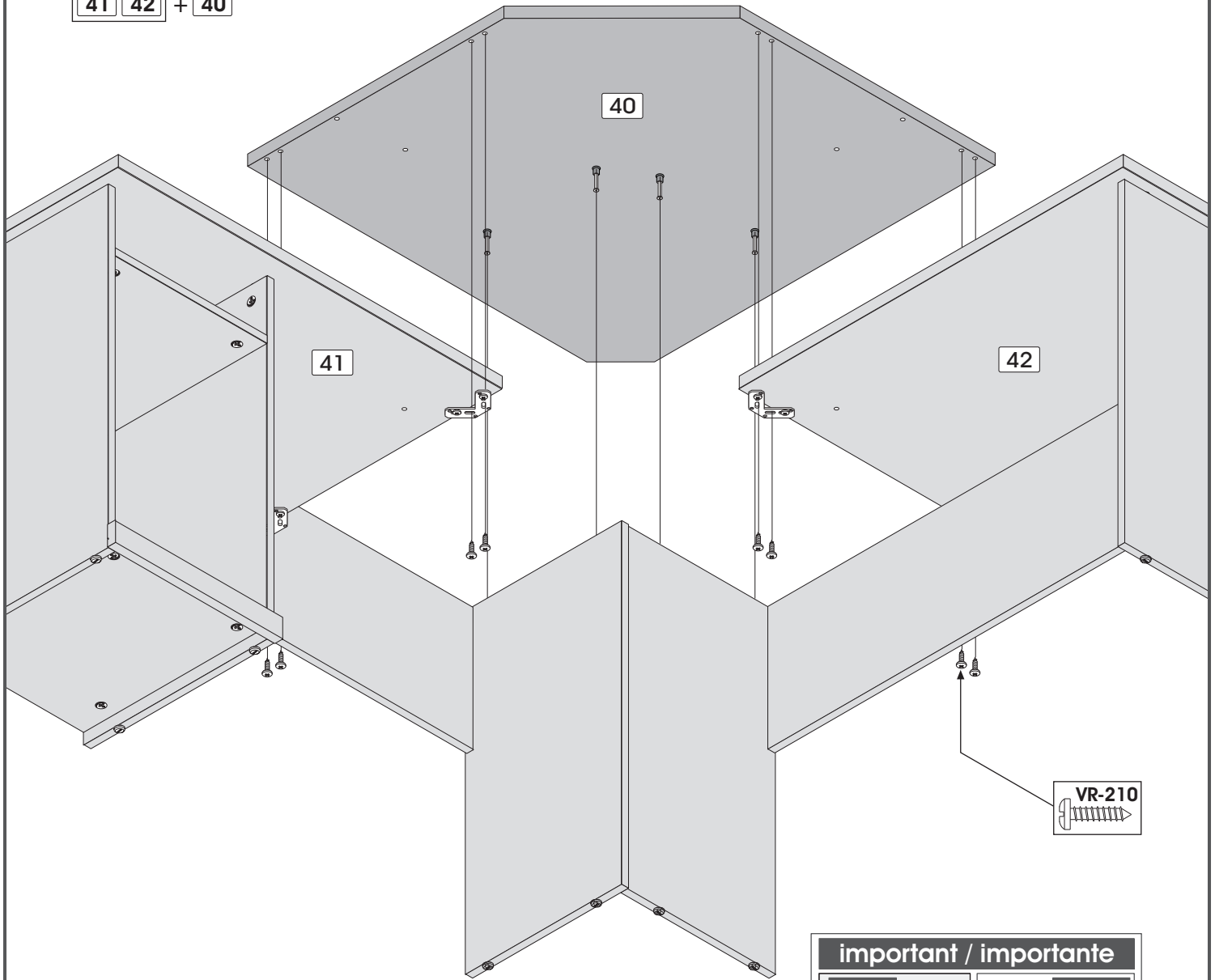

8



5/8" (16 mm)

Code / Código VR-210

Qty / Qté / Cant. x 8

important / importante

A

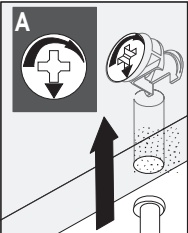

↑
insert
insérez
insertar

B

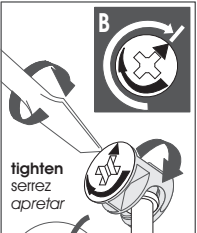

tighten
serrez
apretar

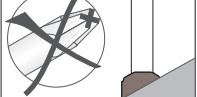

Hutch / Étagère / Estantería

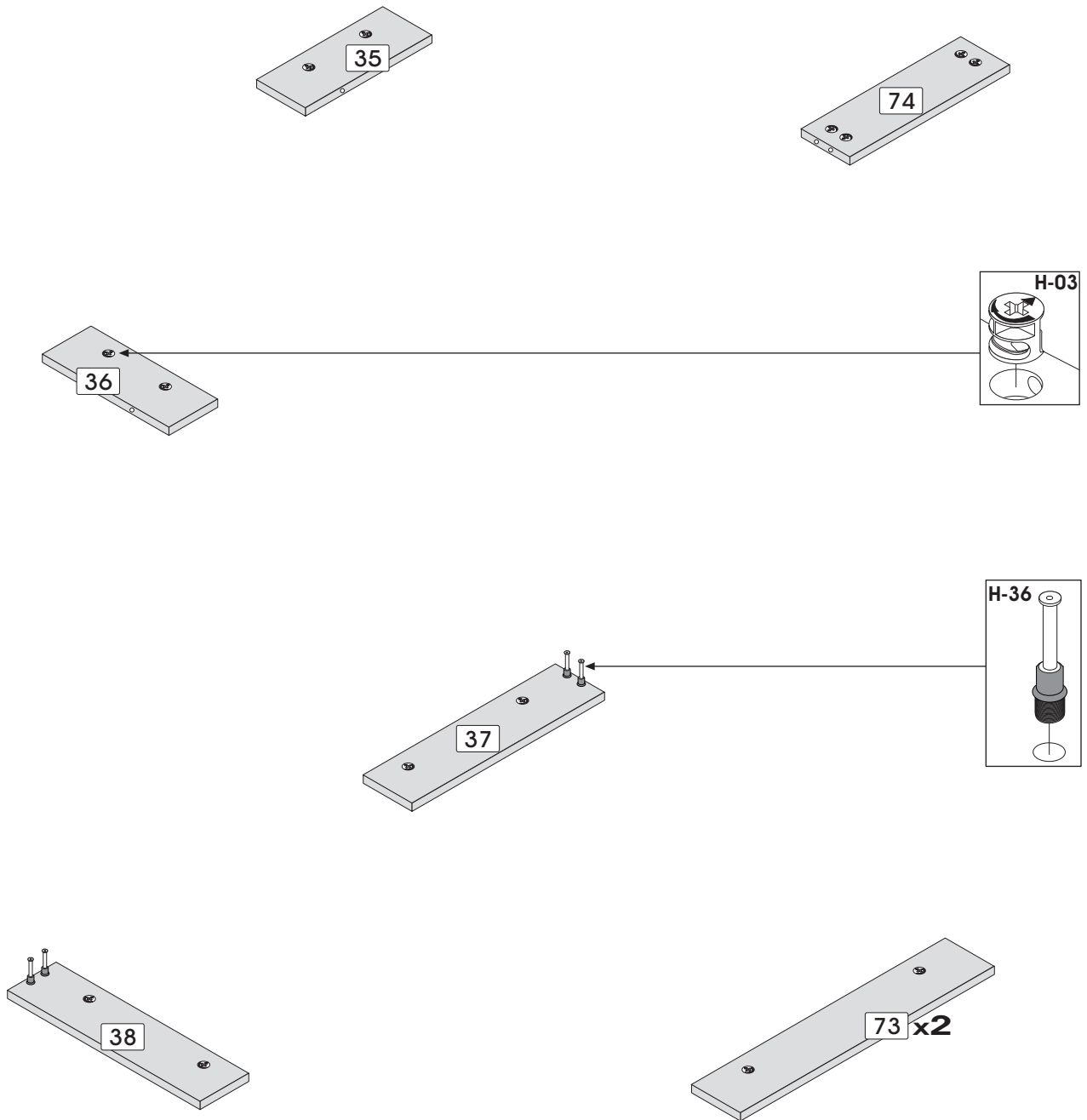

9

Code / Código

H-03

H-36

Qty / Qté / Cant.

x 16

x 4

Hutch / Étagère / Estantería

important / importante

Drive the screw all the way in to install CO-843.

Vissez à fond avant d'installer la CO-843.

Atornille a fondo antes de instalar el CO-843.

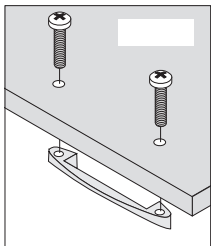
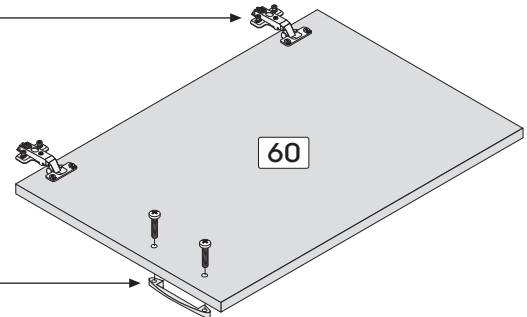
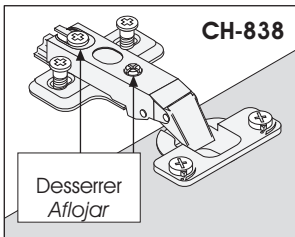
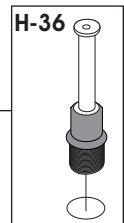
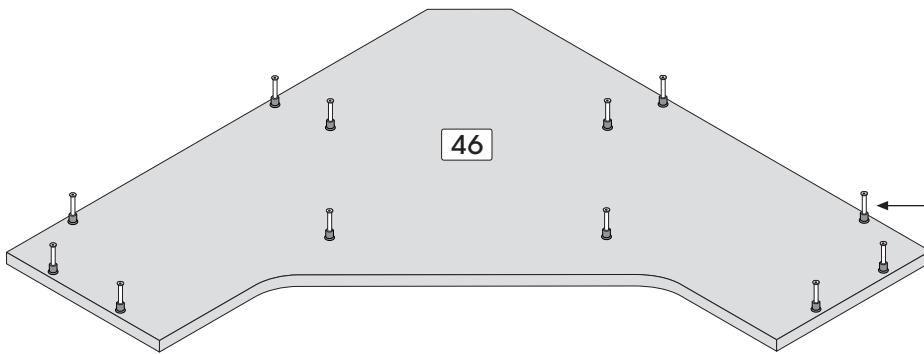
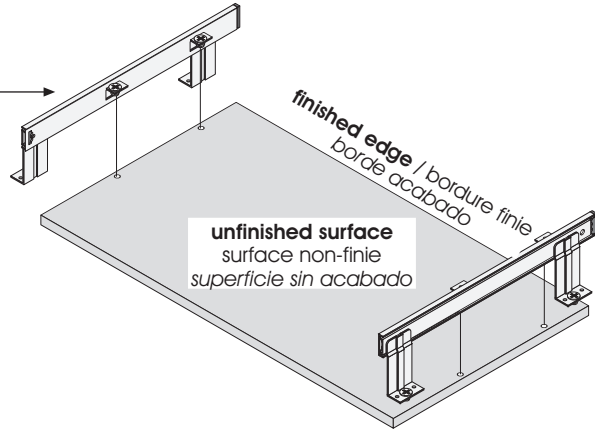
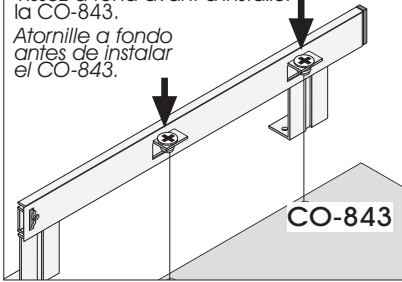

Code / Código	H-36	PO-831	CH-838	CO-843	VF-231
Qty / Qté / Cant.	x 12	x 1	x 2	x 1	x 2

Hutch / Étagère / Estantería

Assemble upside down

Assemblez en position renversée

Realice el ensamblaje en posición invertida

Assembling sequence

Séquence d'assemblage

Secuencia de ensamblaje

Parts / Pièces / Piezas:

38 74 37 + **46** + **36 73** + **73 35**

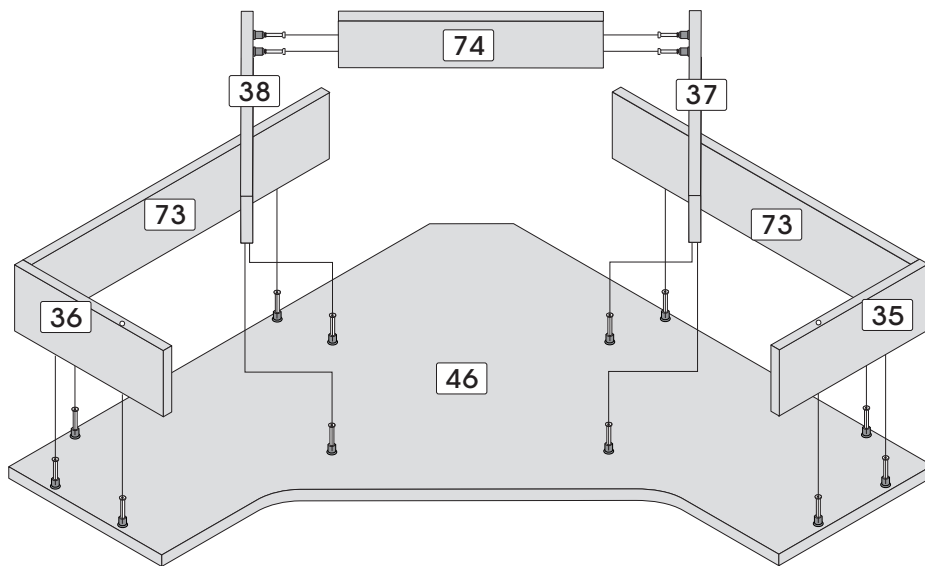

two people are required to assemble and move this model.

deux personnes sont requises pour assembler et déplacer ce modèle.
se necesitan dos personas para ensamblar y desplazar este mueble.

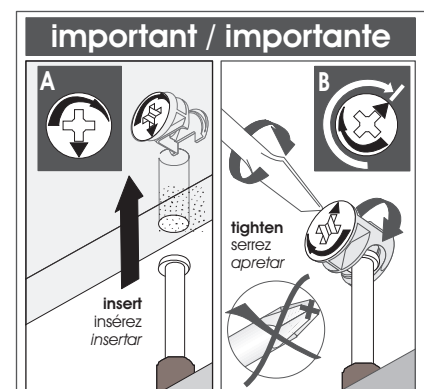

Underneath View

Vue de dessous
Visión de debajo

Assembling sequence

Séquence d'assemblage
Secuencia de ensamblaje

Parts / Pièces / Piezas:

41 40 42 + **35 36**

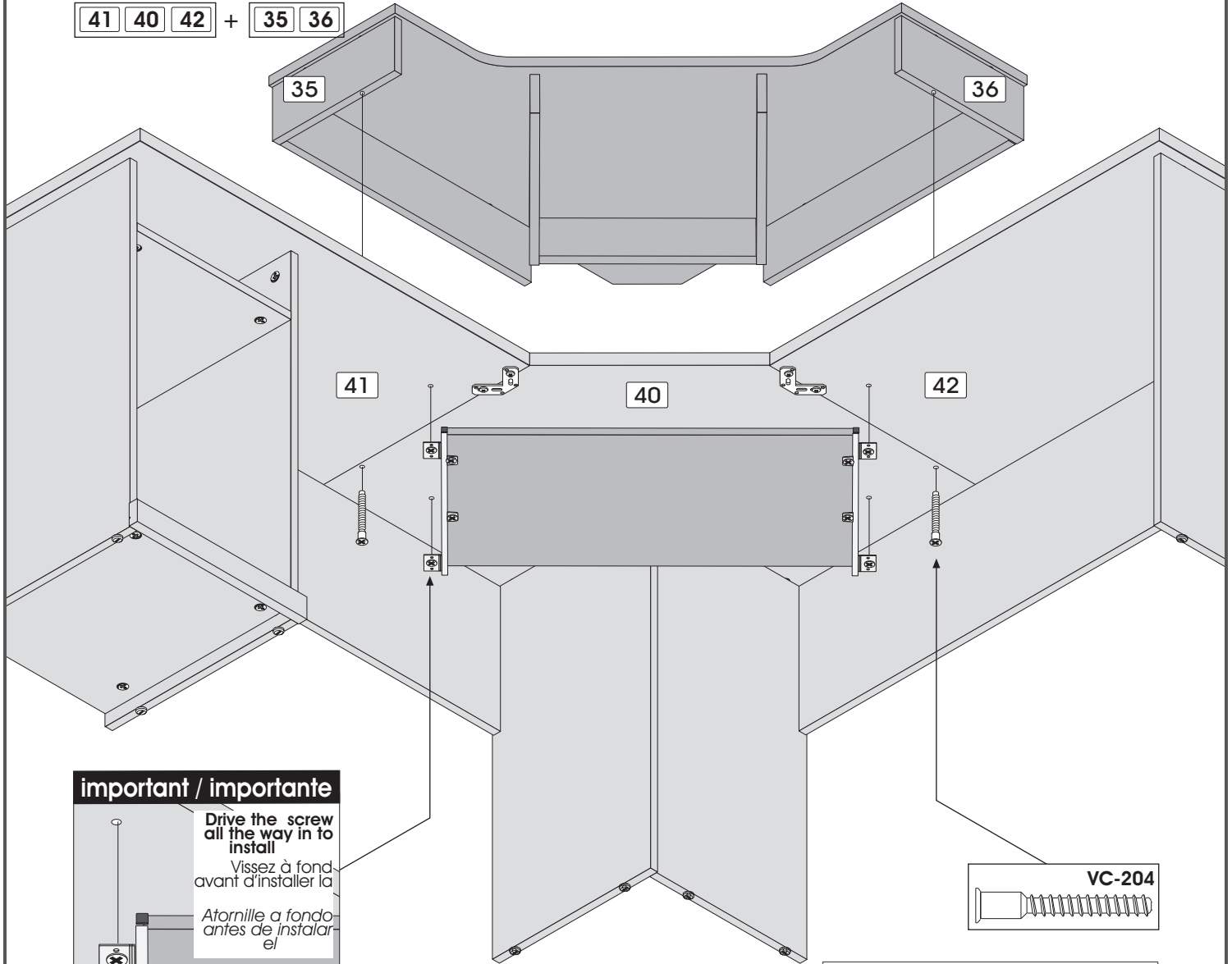

important / importante

Drive the screw all the way in to install
Vissez à fond avant d'installer la
Atornille a fondo antes de instalar el

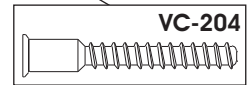

12

VC-204
2" (50 mm)

Code / Código
Qty / Qté / Cant. x 2

two people are required to assemble and move this model.
deux personnes sont requises pour assembler et déplacer ce modèle.
se necesitan dos personas para ensamblar y desplazar este mueble.

important / importante

A insert
insérez
insertar

B tighten
serrez
apretar

13 INSTALLATION / INSTALLATION / INSTALACIÓN

Use screw A for horizontal adjustment, screw B for depth adjustment and screws C for vertical adjustment.

Utilisez la vis A pour l'ajustement horizontal, les vis B pour l'ajustement en profondeur et les vis C pour l'ajustement vertical.

Utilice el tornillo A para realizar el ajuste horizontal, los tornillos B para el ajuste de profundidad y los tornillos C para el ajuste vertical.

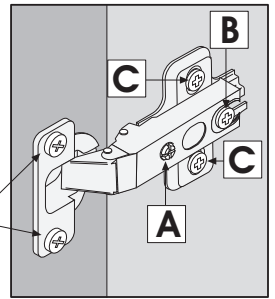

To remove hinges, start by loosening these two screws to free the locking system.

Pour enlever les pentures, desserrez ces deux vis d'abord pour libérer le système de verrouillage.

Para retirar las bisagras, afloje primero estos dos tornillos para liberar el sistema de fijación.

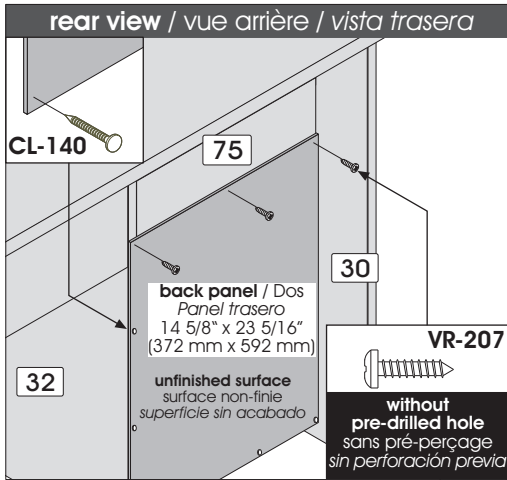

Important/Importante

If you are using the closed storage portion of your unit for your CPU, do not install back panel.

Ne pas faire l'installation du dos si vous utilisez l'armoire pour le rangement de l'unité centrale.

No hagan la instalacion de la espalda si van a utilizar el armario para la ordenacion de la unidad central

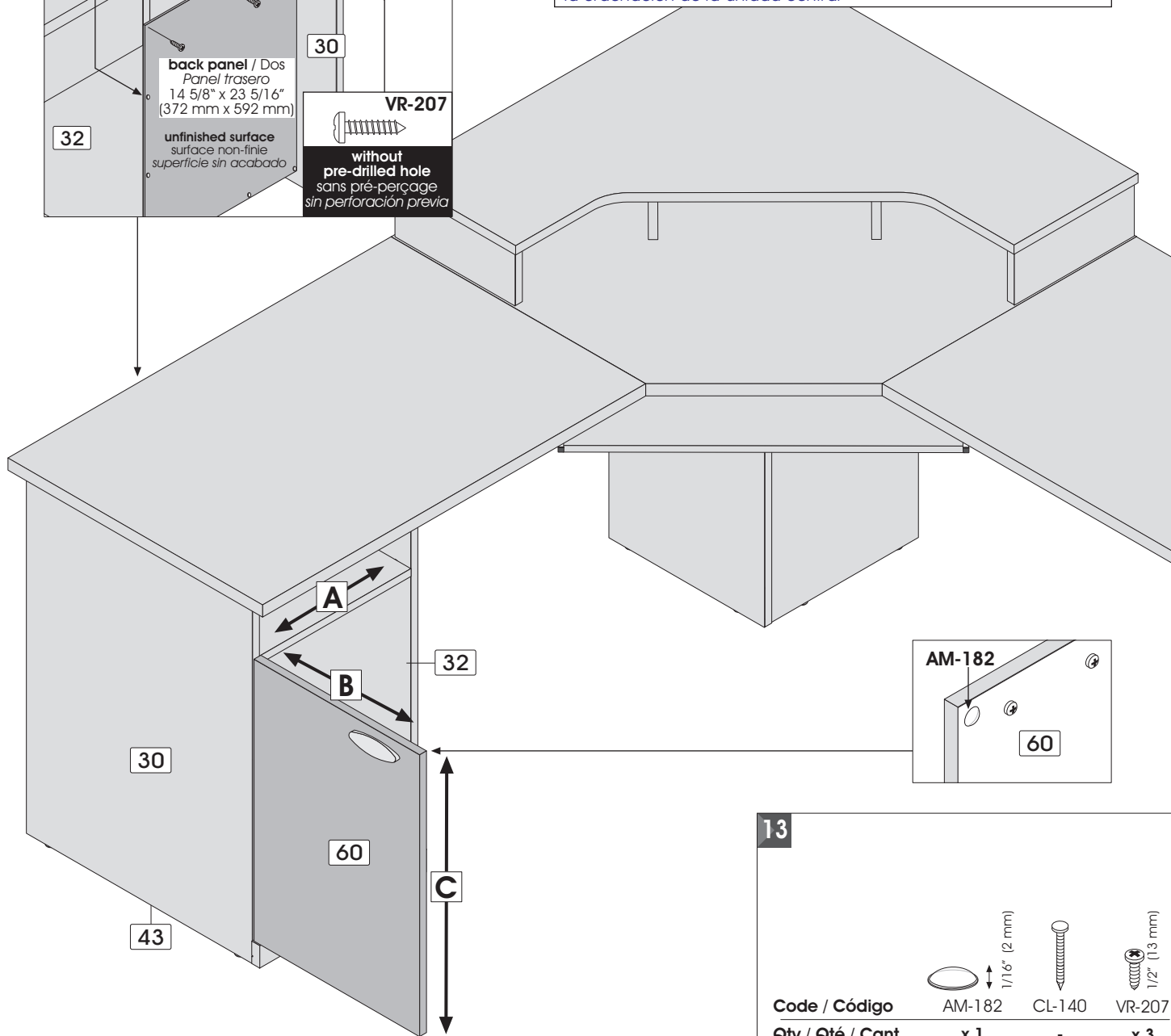

13	
Code / Código	AM-182 CL-140 VR-207
Qty / Qté / Cant.	x 1 - x 3

Important/Importante

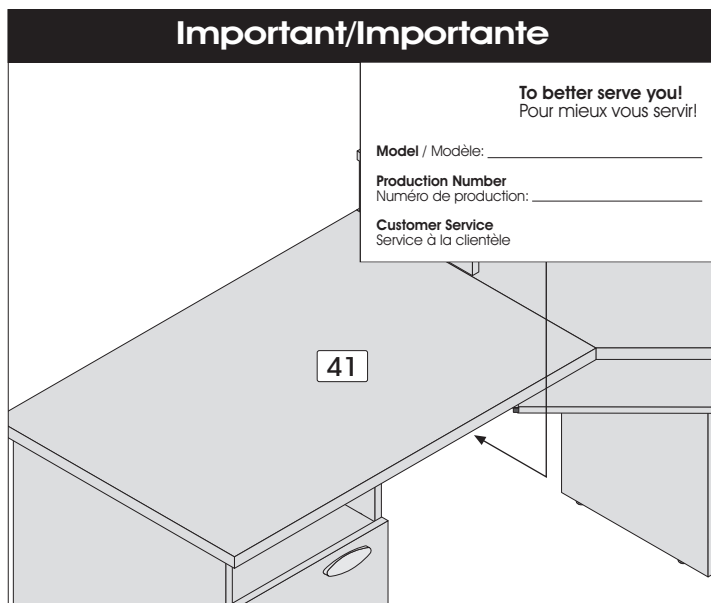

For future reference and to better serve you, please complete and apply the self-adhesive sticker in an accessible space such as under the part 41.

Pour mieux vous servir en cas de besoin, veuillez compléter et apposer l'autocollant dans un endroit facilement accessible tel que le dessous de la pièce 41.

Para uno mejor servicio en caso de necesidad, poner la etiqueta en un lugar de fácil acceso como por ejemplo la parte inferior de la pieza 41.

When you have completed the assembly of your new furniture, install plastic caps
Lorsque vous avez complété l'assemblage de votre meuble, installez les capuchons de plastique
Una vez que haya completado el ensamblaje del mueble, coloque los capuchones de plástico

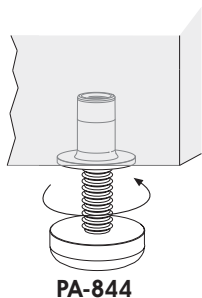
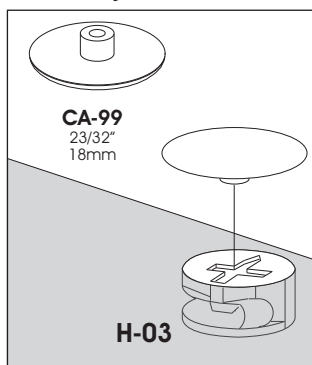

To level your furniture, use leg levelers.

Pour niveler votre meuble utilisez les pattes ajustables.

Para nivelar su mueble utilice las patas ajustables.

PRODUCT CARE / ENTRETIEN DU PRODUIT / MANTENIMIENTO DEL PRODUCTO

Avoid placing the furniture in the sunlight or near a source of heat. Use a soft dry cloth for dusting. To clean heavy dirt, use a cloth dipped in a solution of mild detergent and water. Avoid leaving wet objects on the surface or using commercial chemical cleaning products.

Évitez d'exposer le meuble au soleil ou près de toute source de chaleur. Pour le nettoyage, utilisez un chiffon doux et sec. Pour la grosse saleté, utilisez un chiffon humidifié avec un peu de détergent dilué dans l'eau. Évitez de laisser des objets mouillés sur la surface de votre meuble ou d'utiliser des nettoyants chimiques.

Evite exponer el mueble al sol o las fuentes de calor. Para limpiarlo, utilice un paño suave y seco. Para limpiar las manchas rebeldes, utilice un trapo húmedo con un poco de detergente diluido en agua. No deje objetos mojados encima del mueble ni utilice limpiadores que contengan productos químicos. química.

CONGRATULATIONS! YOU ARE NOW THE OWNER OF A QUALITY PRODUCT
FÉLICITATIONS! VOUS AVEZ MAINTENANT EN VOTRE POSSESSION UN PRODUIT DE QUALITÉ
FELICITACIONES! AHORA ES USTED DUEÑO DE UN PRODUCTO DE CALIDAD.

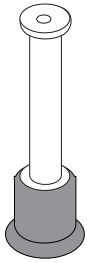

You are at a step of hardware installation and some H-36 are missing: Before calling to order your missing bolts (H-36), please make sure you have not installed any bolts (H-36) in the wrong place. To remove a bolt (H-36) which is not in the correct place, please refer to your instruction manual.

Vous êtes à une étape d'installation de quincaillerie et il vous manque des H-36 : Avant d'appeler pour commander des boulons (H-36), assurez-vous de ne pas avoir installé des boulons (H-36) au mauvais endroit. Pour enlever un boulon (H-36) mal situé, consultez le feuillet d'instructions.

Usted está en alguna etapa de la instalación de quincallas y le faltan las H-36 : Antes de llamar para pedir los pernos (H-36), asegúrese de que no los haya instalado en el lugar equivocado. Para retirar un perno (H-36) mal puesto, consulte el folleto de instrucciones.

How to separate and install your CO-249 and CO-684 slides: The CO-249 & CO-684 slides consist of two sections which you must separate. To separate the slides, please refer to your instruction manual. The slides are installed on distinct parts which will be re-grouped only when the drawers are installed on the furniture.

Comment séparer et installer les coulisseaux CO-249 et CO-684 : Les coulisseaux CO-249 et CO-684 sont constitués d'une partie que vous devez séparer en deux sections. Pour séparer le coulisseau, référez-vous au feuillet d'instructions. Les coulisseaux sont installés sur deux pièces distinctes et seront regroupés seulement lors de l'installation des tiroirs dans le meuble.

Cómo separar y instalar las guías correderas CO-249 y CO-684 : Las guías correderas CO-249 y CO-684 están constituidas por una parte que usted debe separar en dos secciones. Para separar las guías correderas, consulte el folleto de instrucciones. Las guías correderas se instalan en dos piezas distintas y sólo serán reagrupadas una vez que se instalen los cajones en el mueble.

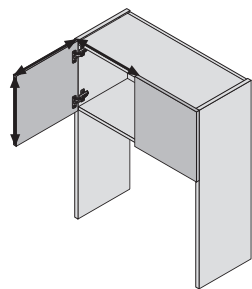
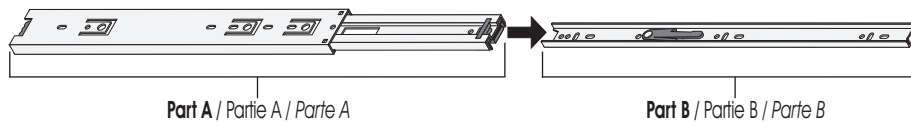

The doors on your furniture are crooked or the space between the doors is uneven: It is very important to install the hinges and hinge plates on the correct parts while respecting the instruction manual. For the installation and adjustment of the doors, please refer to your instruction manual or log on to the internet site

Les portes de votre meuble sont croches ou l'espace qui les sépare est inégal : Il est important d'installer les pentures et les plaques sur les bonnes pièces en respectant le feuillet d'instructions. Pour l'installation des portes et leur ajustement, référez-vous à l'étape d'installation des portes dans le feuillet d'instructions ou sur le site internet

Las puertas de su mueble están chuecas o el espacio que las separa es desigual : Es importante instalar las bisagras y las placas sobre las piezas adecuadas respetando el folleto de instrucciones. Para la instalación de las puertas y su ajuste, consulte la etapa de instalación de las puertas en el folleto de instrucciones o en el sitio Internet

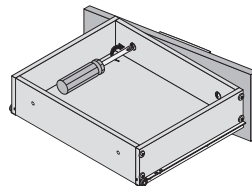

The drawers on your furniture are crooked or the space between the drawers is uneven: While referring to the section indicating the actual sizes of the screws in your instruction manual, please insure that you are using the correct size screws needed when installing your drawer slides and drawer fronts. They must be installed straight. While installing the drawer front, make sure that the correct side is facing up. For the adjustment of the drawer fronts, please refer to your instruction manual or log on to the internet site

Les tiroirs de votre meuble sont croches ou l'espace qui les sépare est inégal : En vous référant au tableau de vis grandeur réelle du feuillet d'instructions, assurez-vous que vous avez utilisé les bonnes vis lors de l'installation des coulisseaux ainsi que du devant de tiroir et qu'elles sont posées bien droites. Assurez-vous également que le devant du tiroir n'est pas assemblé à l'envers. Référez-vous à l'étape d'ajustement des tiroirs dans le feuillet d'instructions ou sur le site internet

Los cajones de su mueble están chuecos o el espacio que los separa es desigual : Consulte la tabla de tornillos en tamaño real del folleto de instrucciones y asegúrese de que haya utilizado los tornillos adecuados durante la instalación de las guías correderas así como también la parte delantera del cajón y que éstos estén puestos bien derechos. Asegúrese también de que la parte delantera del cajón no esté ensamblada al revés. Consulte la etapa del ajuste de cajones en el folleto de instrucciones o en el sitio Internet



For more information or to discover our new products

Pour toute information ou pour découvrir nos nouveaux produits

Para obtener más información o para obtener nuevos productos



OUR FURNITURE IS GARANTEED FOR 10 YEARS. NO MATTER THE PROBLEM, OUR CUSTOMER SERVICE IS THERE FOR YOU.

NOS MEUBLES SONT GARANTIS POUR 10 ANS. PEU IMPORTE LE PROBLÈME, N'HÉSITÉZ PAS À COMMUNIQUER AVEC NOTRE SERVICE À LA CLIENTÈLE.

NUESTROS MUEBLES TIENEN UNA GARANTIA DE 10 AÑOS. NO IMPORTA EL PROBLEMA, COMUNIQUE CON NUESTRO SERVICIO À CLIENTE.