

6' Picnic Table

Assembly Guide

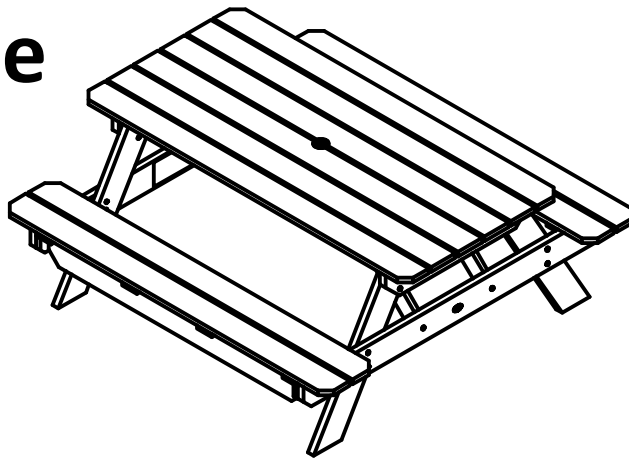

*Actual Style May Vary from the One Pictured in this Guide

TBL-HI02

HARDWARE INCLUDED

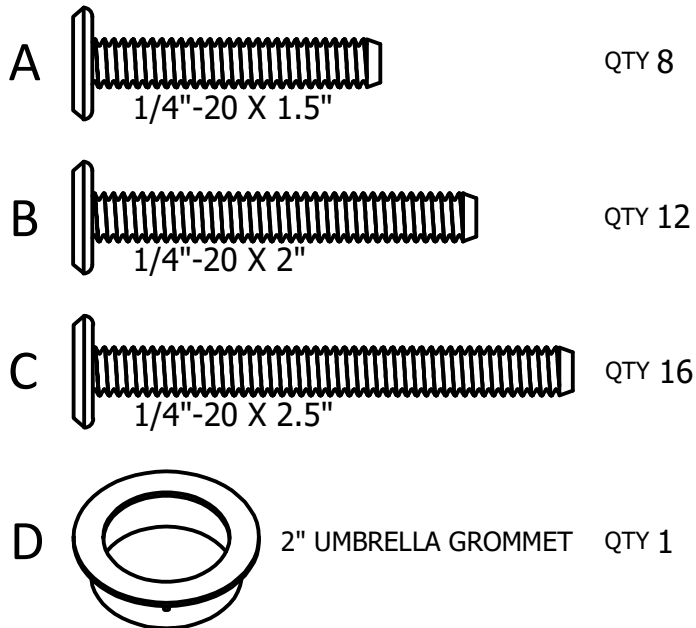

TOOLS INCLUDED

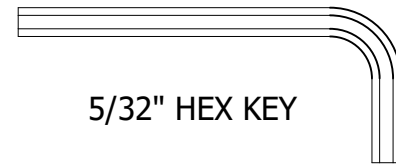

5/32" HEX KEY

IMPORTANT!

DO NOT fully tighten bolts until all bolts are started.

Leg Assembly

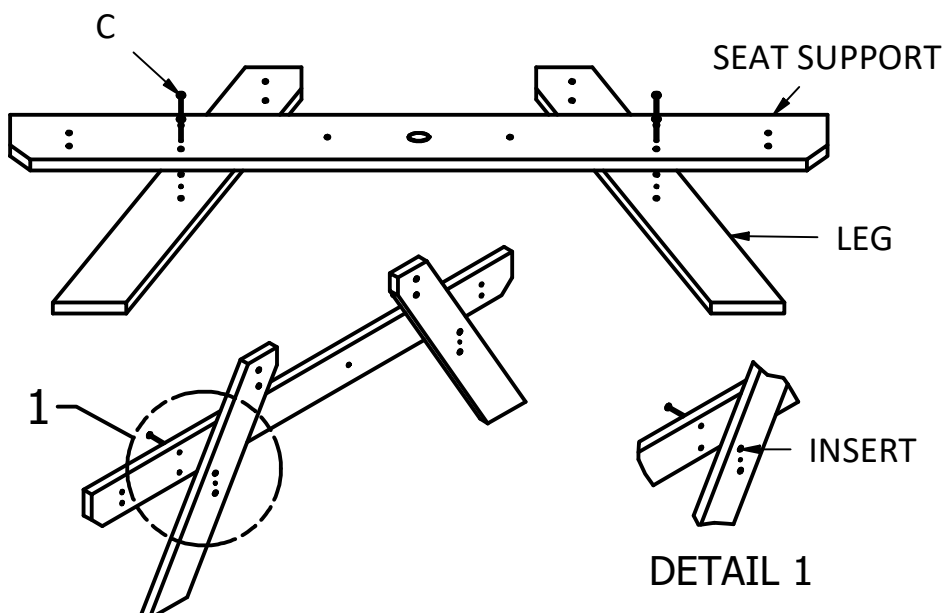

1) Start by Placing Both Legs with the Insets facing **DOWN** as shown in Detail 1.

2) Attach the Seat Support to the Legs with (4) **C** Bolts.

3) Repeat (1) and (2) for the Other Leg Assembly.

LEG ASSEMBLY

TABLE TOP

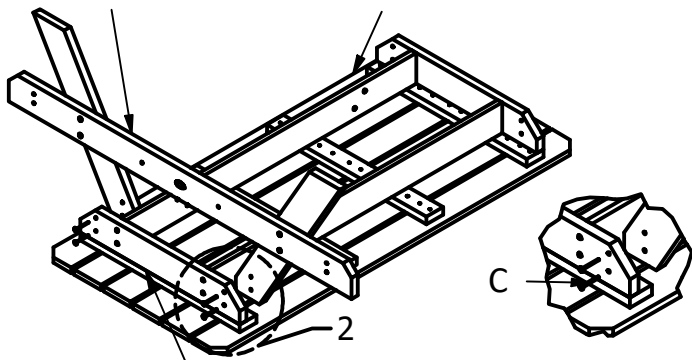

TABLE TOP END SUPPORT

DETAIL 2

4) Start by Placing the Table Top Facing **Down** as Shown here to the Left.

5) Attach the Leg Assembly to the Table Top End Support with (4) **C** Bolts. Ensure the Seat Support Faces the Outside of the Table as Shown to the Left.

6) Repeat (4) and (5) for the Other Leg Assembly on the Opposite Side of the Table Top.

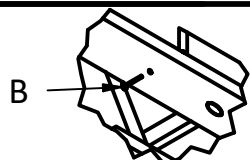

BRACE

BRACE

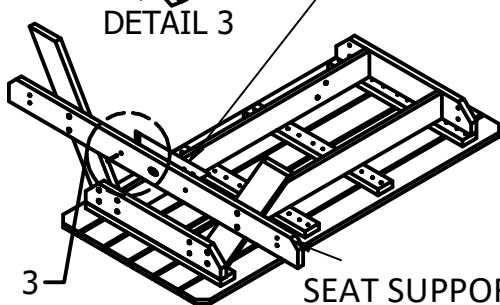

DETAIL 3

SEAT SUPPORT

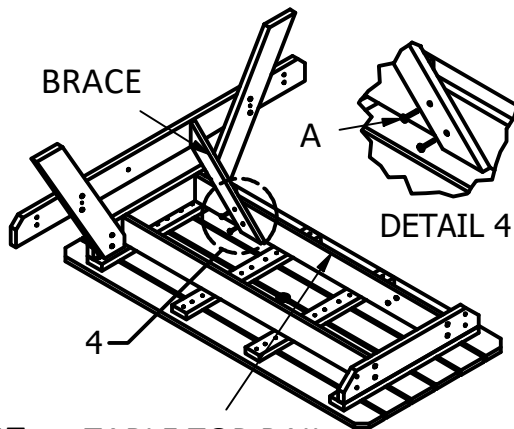

DETAIL 4

TABLE TOP RAIL

7) Attach the Brace to the Seat Support using (1) **B** Bolt. Reference Detail 3.

8) Attach the other end of the Brace to the Table Top Rail using (2) **A** Bolts. Reference Detail 4.

9) Repeat (7) and (8) to attach the 3 other Braces on each Corner of the Frame.

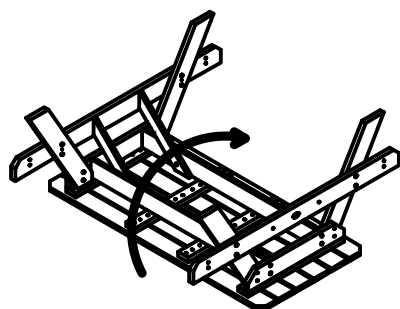

DETAIL 5

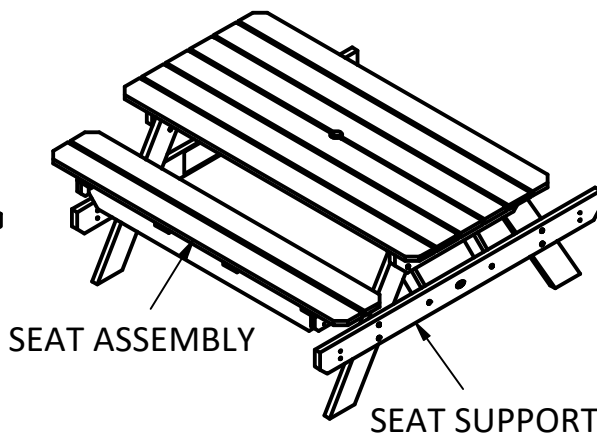

SEAT ASSEMBLY

SEAT SUPPORT

10) Once all Braces are attached, as Shown in Detail 5, Flip the Table Upright With the Help From Another Person.

11) Line Up the Seat Assembly With the Bolt Holes in the Seat Support.

12) Repeat (11) for the Other Seat Assembly.

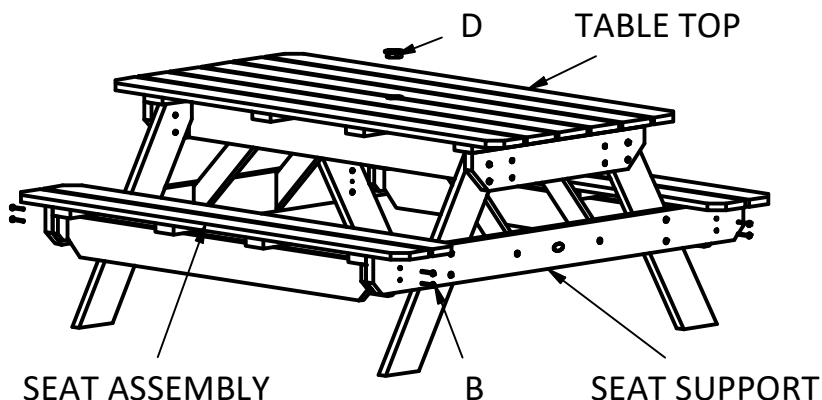

SEAT ASSEMBLY

B

SEAT SUPPORT

D

TABLE TOP

13) Attach the Seat Assembly to the Seat Support Using (4) **B** Bolts. Repeat for the Other Seat Assembly.

14) Place the Umbrella Gromet (**D**) in the Cutout of the Table Top.