

Limited Warranty

What is Not Covered?

Our limited warranty does not cover any problem that is caused by:

1. Conditions, malfunctions or damage not resulting from defects in material or workmanship.
2. Conditions, malfunctions or damage resulting from normal wear and tear, improper installation, improper maintenance, misuse, abuse, negligence, accident or alteration.
3. Accessories, connected materials and products, or related products not manufactured by FlexiSpot.
4. Conditions, malfunctions or damage resulting from failure to follow the instructions and guidelines relating to the product's intended use.

Our limited warranty is void if a product is returned with removed, damaged or tampered labels or any alterations (including removal of any component or external cover).

How to File a Claim?

In order to receive the benefit of our limited warranty, you need to process your claim in compliance with the terms of this limited warranty and follow proper return procedure. You will need to provide the sales receipt or other evidence of date and place of purchase

Implied Warranties and Limitation of Damages

EXCEPT TO THE EXTENT PROHIBITED BY APPLICABLE LAW, ALL IMPLIED WARRANTIES (INCLUDING WARRANTIES OF MERCHANTABILITY AND FITNESS FOR A PARTICULAR PURPOSE) SHALL BE LIMITED IN DURATION TO THE DURATION OF THIS WARRANTY, AND FLEXISPOT SHALL NOT BE LIABLE FOR ANY INCIDENTAL, INDIRECT, SPECIAL, OR CONSEQUENTIAL DAMAGES, INCLUDING BUT NOT LIMITED TO LOSS OF PROFITS OR REVENUE, RESULTING FROM ANY BREACH OF EXPRESS OR IMPLIED WARRANTY OR CONDITION, OR UNDER ANY OTHER LEGAL THEORY, EVEN IF FLEXISPOT HAS BEEN ADVISED OF THE POSSIBILITY OF SUCH DAMAGES. Some jurisdictions do not allow limitations on the duration of an implied warranty or the exclusion or limitation of special, indirect, incidental or consequential damages, so the above limitations or exclusions may not apply to you.

Governing Law

This Warranty shall be governed by the laws of the State of California, USA, without giving effect to any conflict of laws principles that may provide the application of the law of another jurisdiction.

How State Law Applies

This Warranty gives you specific legal rights, and you may also have other rights which vary from state to state.

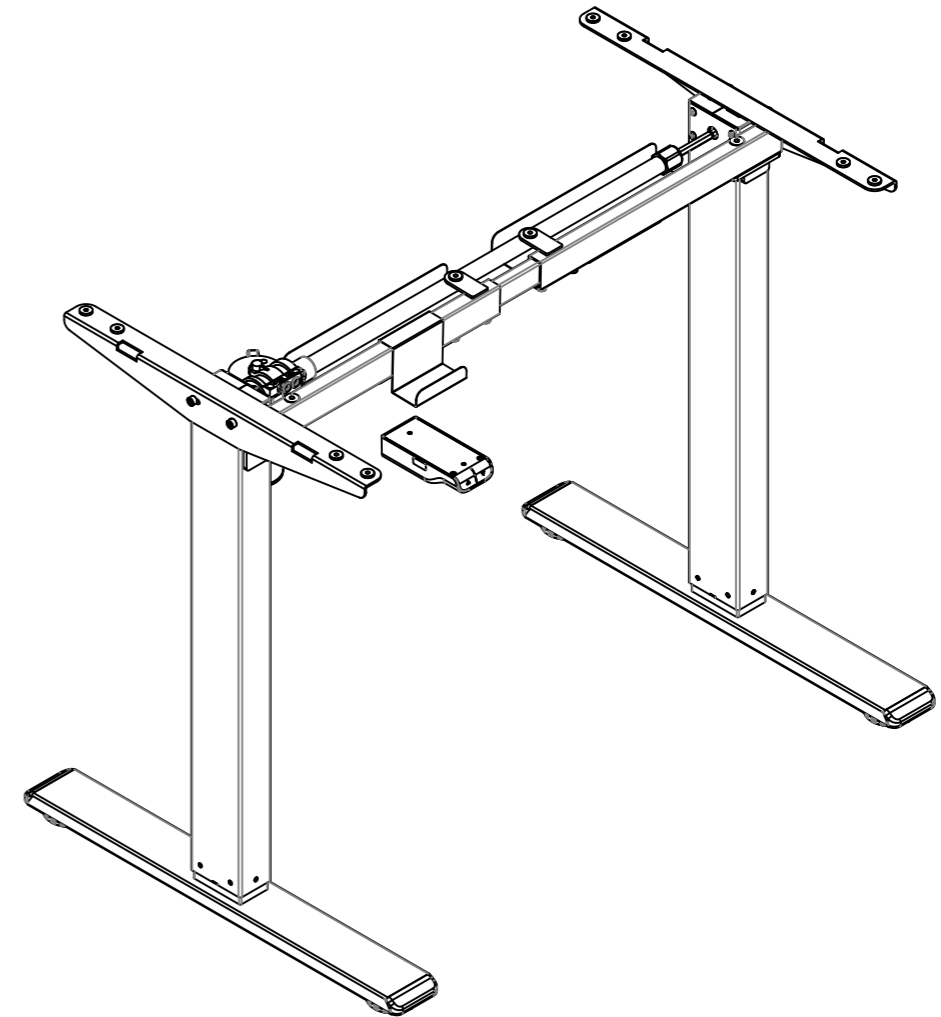

Installation Guide

Specifications

Max. Weight Capacity	154 lbs (70 kg)
Max. Speed	1"/s
Input Voltage	100 - 240 V
Min. Height	28" (710 mm)
Max. Height	47.6" (1210 mm)
Desktop Size	39.3" - 63"(1000 -1600 mm) in width and 19.7" - 31.5"(500 -800 mm) in depth
Duty Cycle	10% (Working 2 minutes then stop 18 minutes)
Working Temperature	32° - 104° F

Accessory Package

Figures shown are for reference only. Please contact customer service if there are any accessory or tools missing.

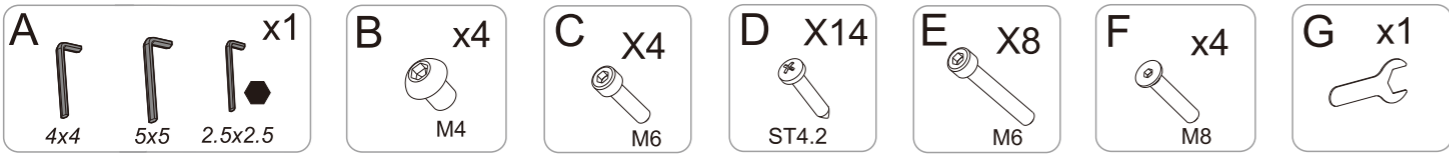

Parts Included

NO.	Parts	Qty	NO.	Parts	Qty
①	Desk foot	2	②	Lifting column	1
③	Lifting column with motor	1	④	Crossbeam	1
⑤	Transmission rod	1	⑥	Support plate	2
⑦	Adapter	1	⑧	Baffle	2
⑨	Power cord	1	⑩	Cable tie	4
⑪	Adapter holder	1	⑫	Keypad	1
⑬	Patch cord	1			

Diagram of Components

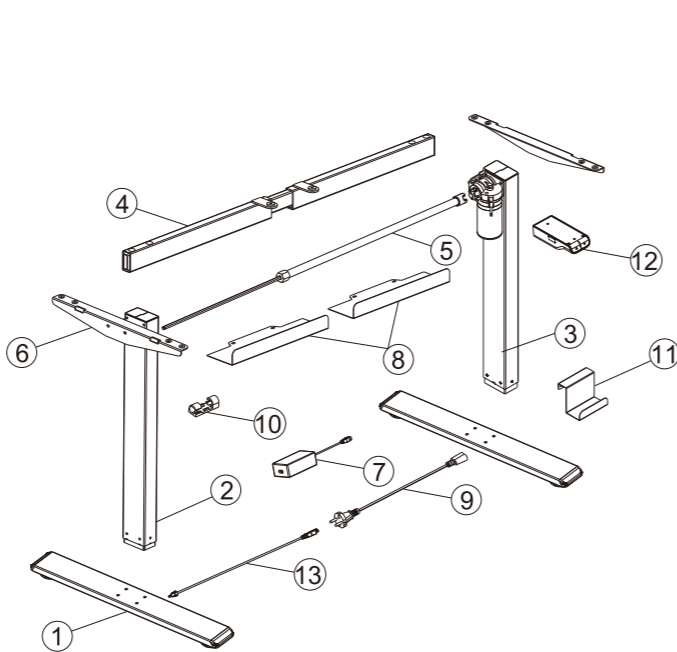

Step 1: Install desk feet

Attach the desk foot (1) to the lifting columns (2 & 3) using 8 M6 bolts (E) and 5x5 hex key (A).

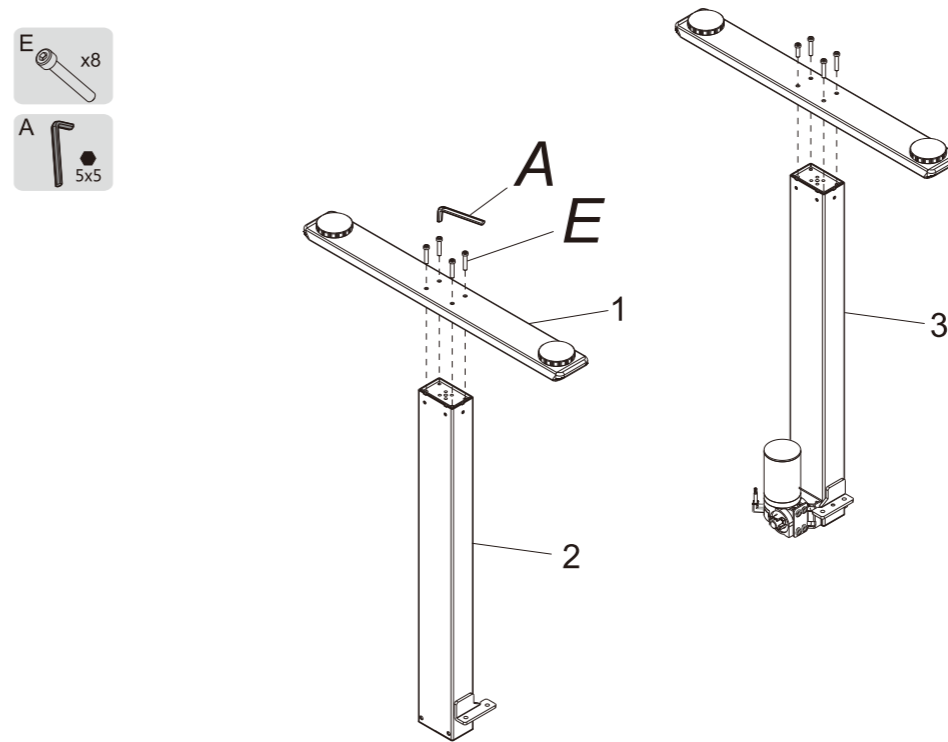

Step 2: Install crossbeam

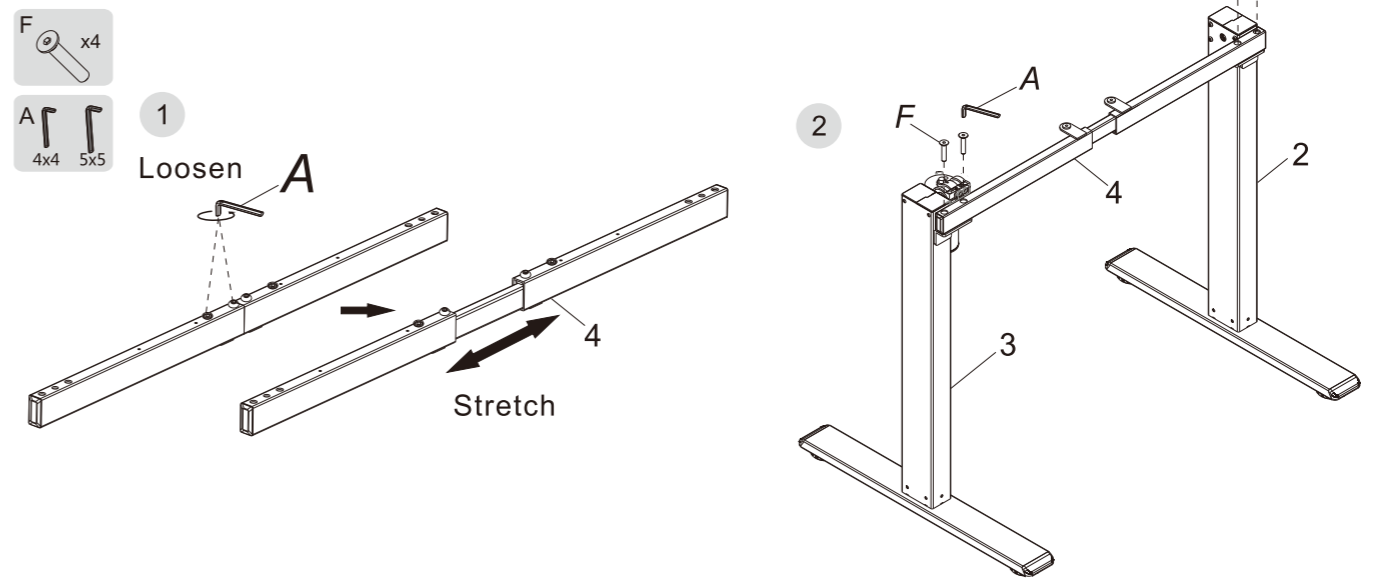

Loosen the 4 bolts in the crossbeam (4) with hex key (A), then stretch the crossbeam out (Figure. 1).

Attach the crossbeam to the lifting columns (2 & 3) with the M8 bolts (F) and tighten them down with the 5x5 hex key (A)(Figure. 2).

Step 3: Install transmission rod

To install the transmission rod (5), first slot it into lifting column (2) and loosen the hex bolt (Figure. 1). Extend the transmission rod and slot it into the motor on lifting column (3), then tighten it down with the included 2.5x2.5 hex key (A) (Figure. 2)

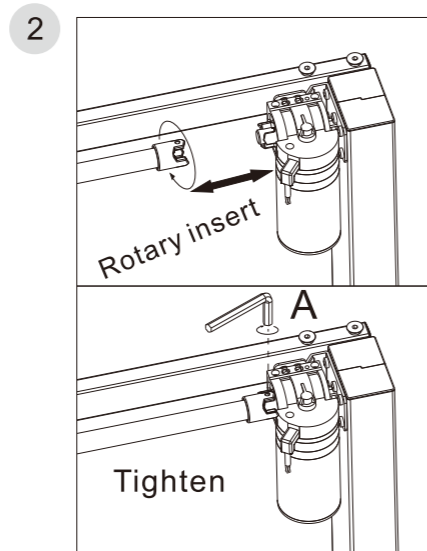
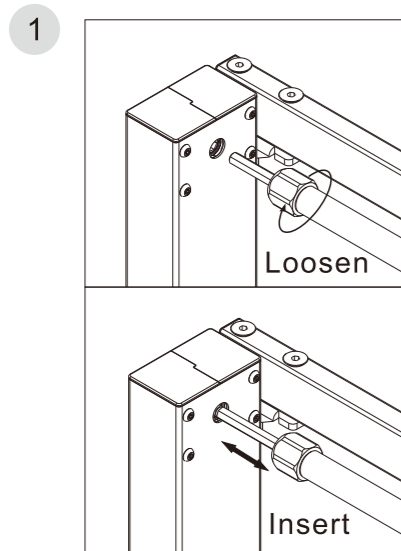

Note: Please insert the transmission rod until shaft stopper touches the column (Figure. 1).

Warning: To ensure both lifting columns move evenly, do not rotate the transmission rod more than 1/3 turn when inserting it into the motor (Figure. 2).

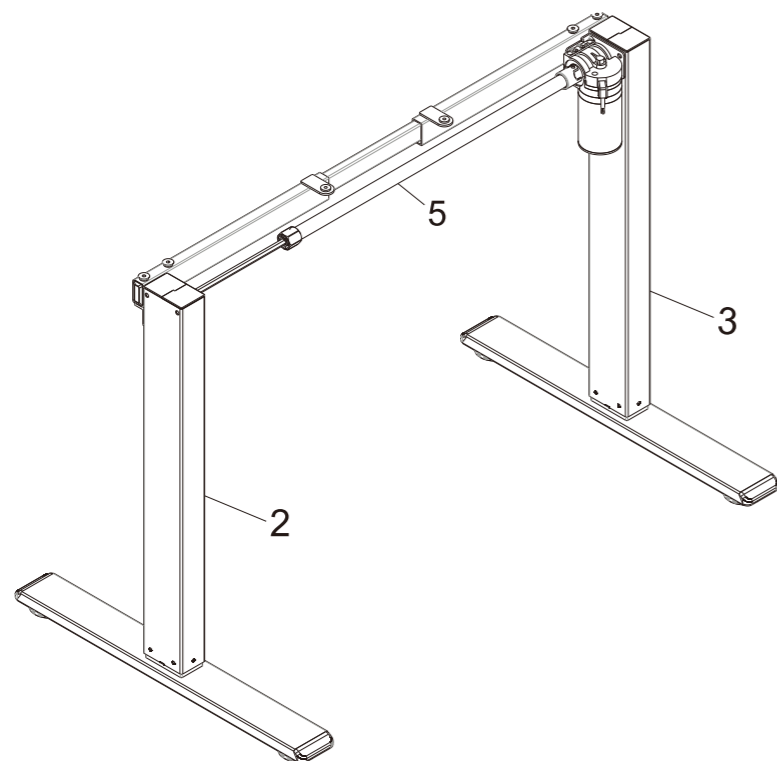

Step 4: Install support plates

Attach the support plates (6) to the lifting columns (2 & 3) using M6 bolts (C). Tighten with 5x5 hex key (A).

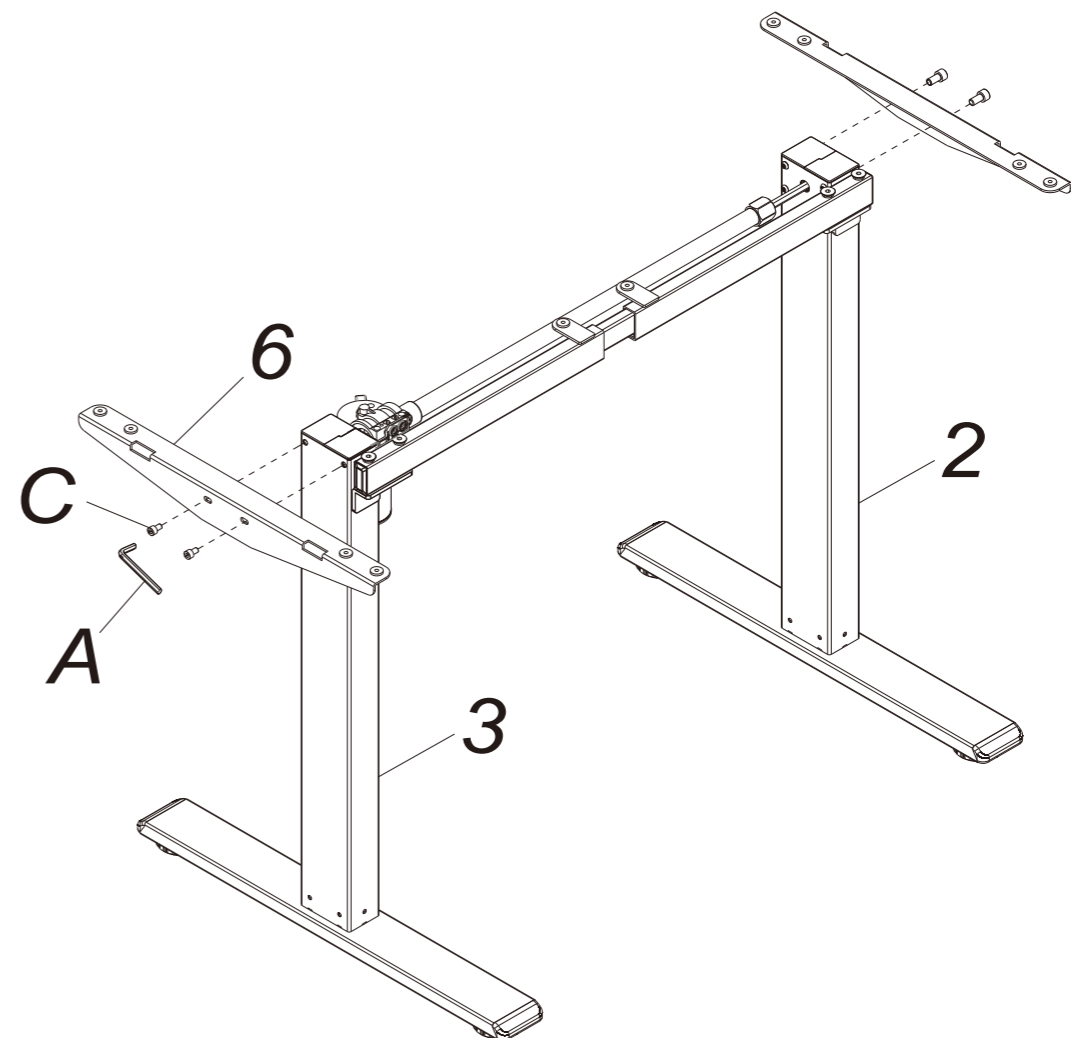

Step 5: Install adapter holder, desktop, and keypad

Put the frame upside down on the underside of the desktop. Adjust the length of transmission rod and crossbeam, carefully line up the frame to match the pre-drilled holes. Attach the adapter holder (11) to the crossbeam (4) (Figure. 1). Attach the frame to the work surface using ST 4.2 screws (D) and tighten with drill (Figure. 2).

1

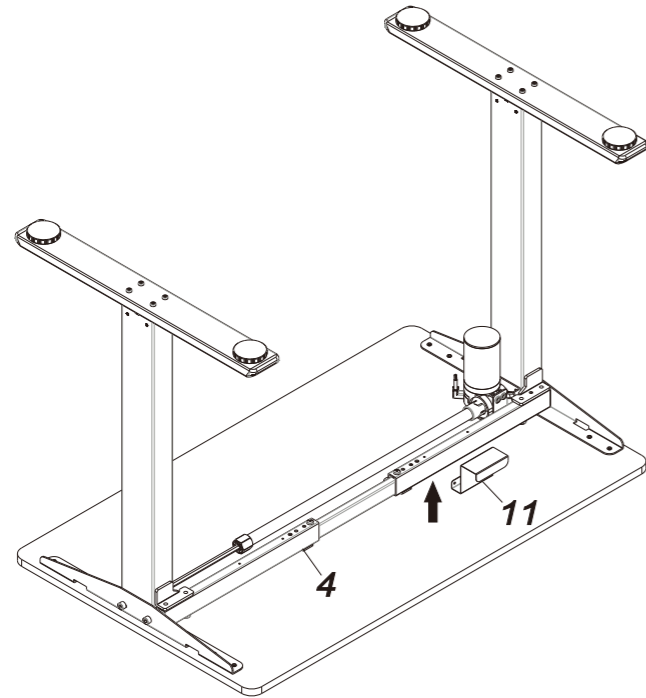

Note: the holes in the adapter holder (11) are not for screws.

2

Warning:
The position of keypad is on the side of the lifting column with the motor.

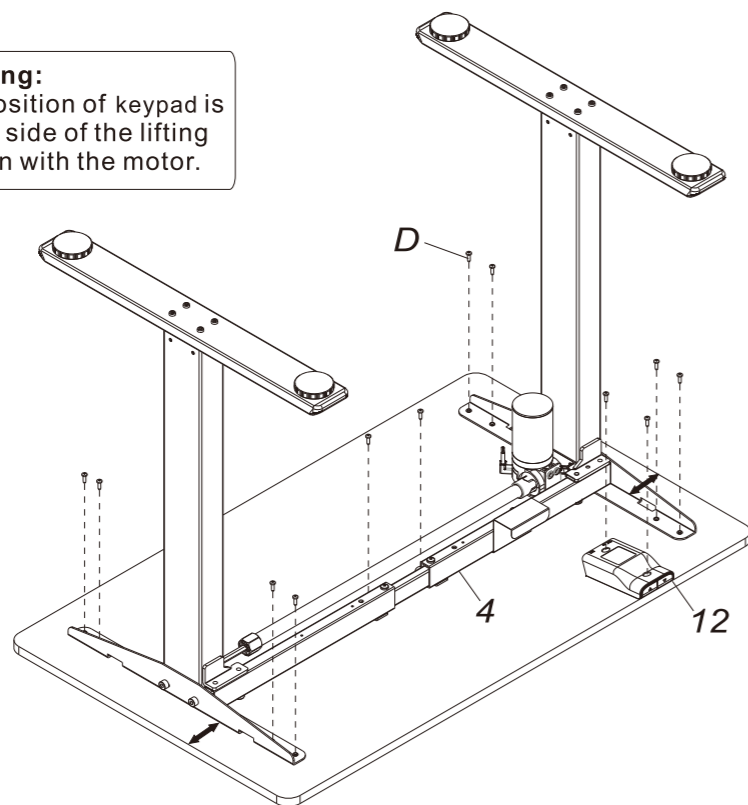

D x12



Prepared by
Customer

Step 6: Tighten the crossbeam and transmission rod

Tighten down the 4 bolts in the crossbeam with the 4x4 hex key (A), and the hex bolt in the middle of the transmission rod with the wrench (G).

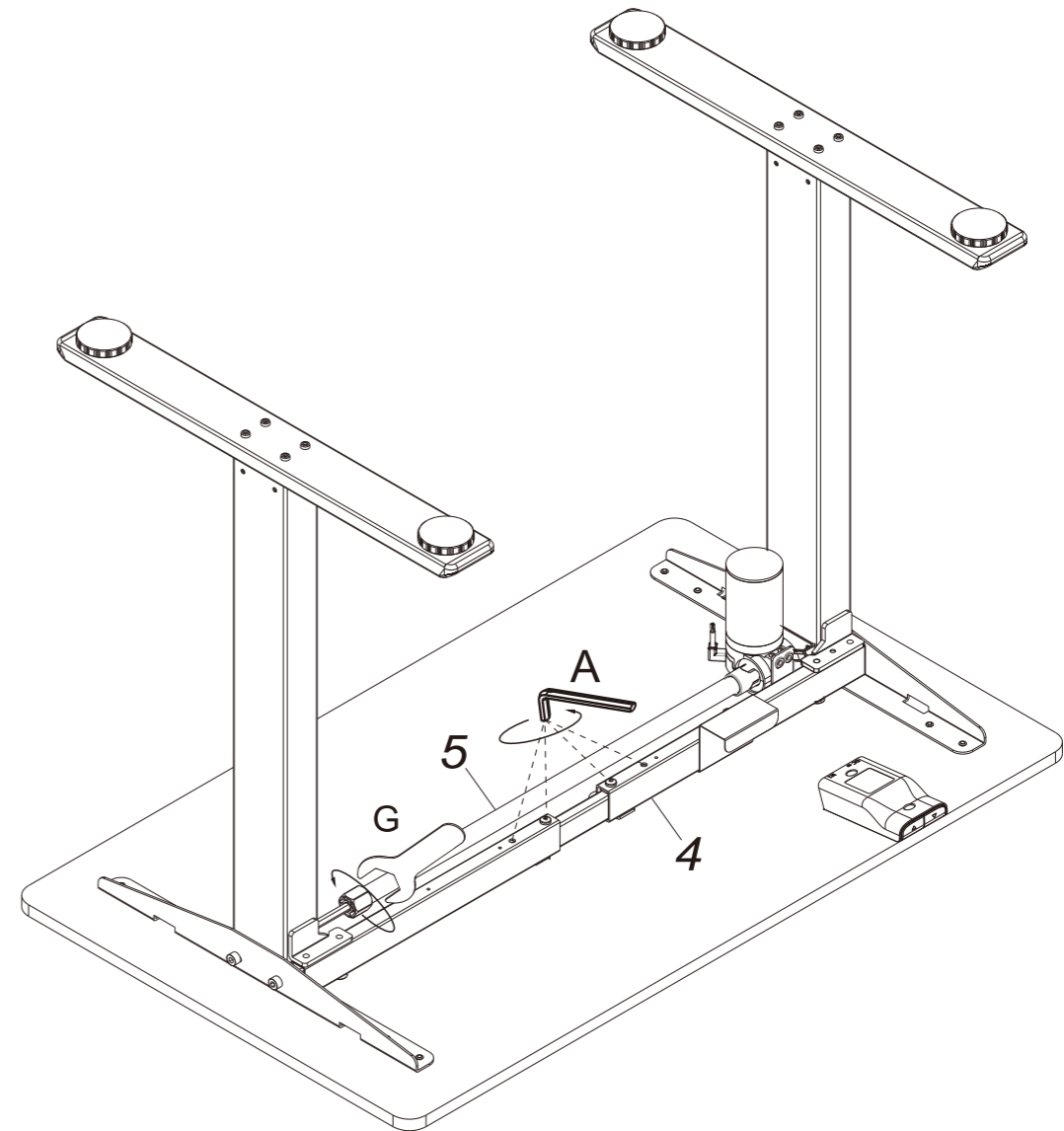

A
4x4

G

Step 7: Install baffle and adapter

Attach the baffle (8) to the crossbeam using M4 bolts(B) and tighten with 2.5x2.5 hex key (A). Insert the adapter (7) into the holder (11).

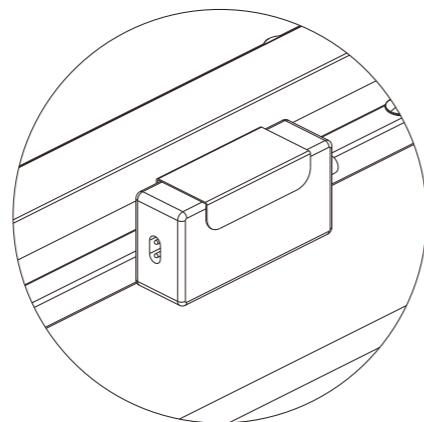
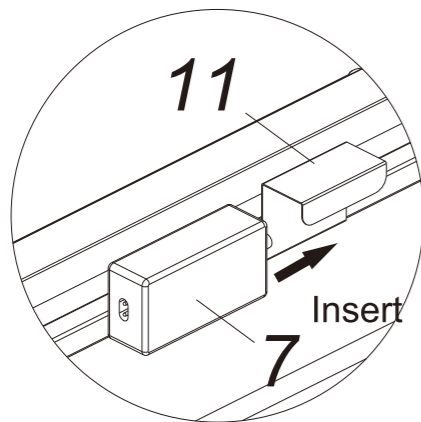
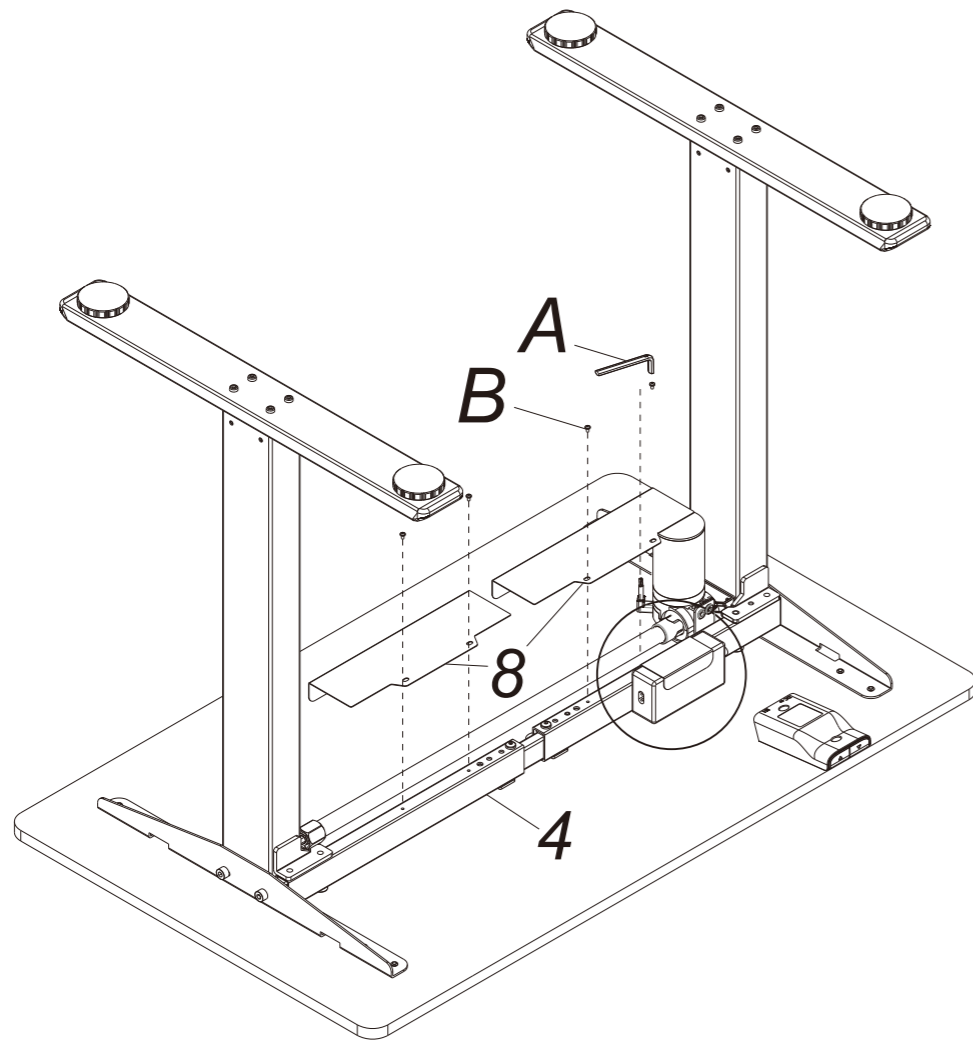

Step 8: Install and sort out power cord

Connect the power cord (9) to the adapter (7) as shown on the picture.

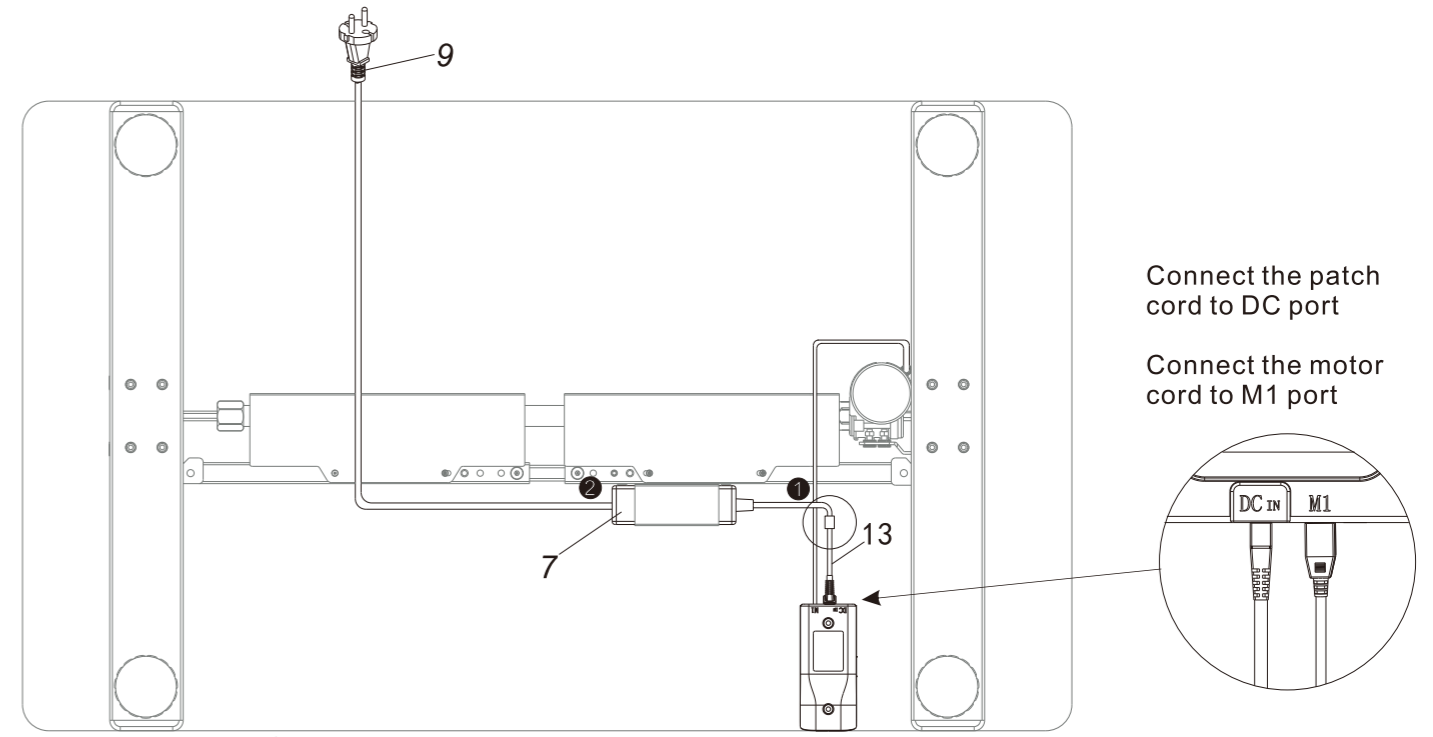

! Connect to wall power ONLY after all other cables are properly connected.

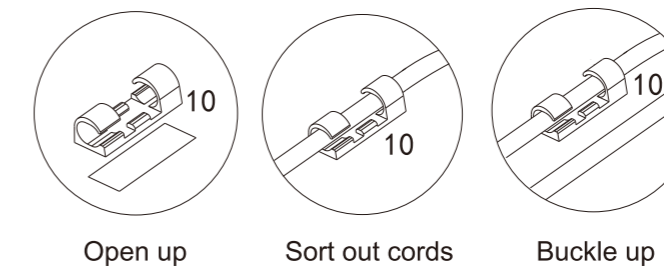
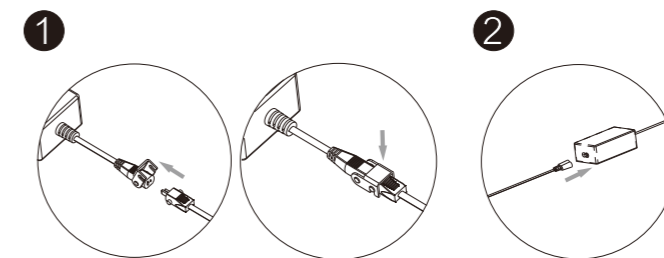

The cable tie (10) can be used to fasten the cables to the desktop.

Keypad Instruction

Keypad

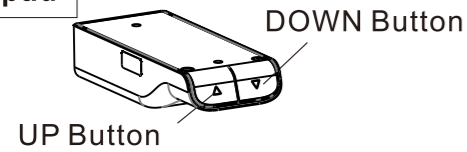

● ▲	UP Button, used to lift the desk surface
● ▼	DOWN Button, used to lower the desk surface

Height adjusting function
Press the UP button or DOWN button to lift or lower the height of desk surface.

●Reset

1. At the lowest position, long press the down button for 5 seconds to enter reset mode. The lifting system will then bottom out and rebound slightly, indicating that the reset is successful.
2. If the lifting system fails, long press the down button until the lifting system bottoms out and rebounds slightly to reset the system.

●Troubleshooting

1. If there is no response to pressing the up or down button after a period of continuous work, please let the desk idle for at least 18 minutes before operating it again.
2. During the lifting process, if the desk reverses its movement unexpectedly, please check whether the desk load is too heavy or if the desk experiences a lot of shaking while in use.
3. If the lifting columns are uneven and/or not the same height, please refer to the "standing desk leg problem" video at <https://www.flexispot.com/deskresources#3> for troubleshooting.

Attention

- Power supply: AC100 - 240 V, frequency 50/60HZ;
- Working environment: 32° - 104° F;
- Before cleaning, you have to unplug the power supply cable. Clean with a slightly damp cloth to wipe away the surface dust. Keep all electrical components away from liquids. Do not damage the connection line and keep the plug in a safe position.
- Inside the control box, there are electronic components, metal parts, plastic parts, wires and so on. They should be disposed in accordance with the local laws and regulations. They cannot be disposed as household waste.
- Before using the product, please make sure the product has been installed correctly.
- Before starting use of the product, please read the instructions to fully understand all the product's functions and settings.
- Keep children away from electric height-adjustable desks, control units and handsets. Manufacturer is not responsible of any damages that result from children's unpredictable behaviour.
- Slight noise caused by the multi wedge belt or brake system will not impact the use of this product.
- Do not use corrosive or abrasive materials to clean this product and please dispose of cleaning solutions in an environmentally friendly manner.
- Understand the risks associated with using this product. Children or those with cognitive impairment should not use this product without supervision.
- If the power supply cord is damaged or broken, it must be replaced by the manufacturer or a relevant specialist to avoid any injuries.
- Please operate in a clean and safe environment. For example, do not left around your tools. And always be careful to deal with packaging materials, in order to avoid any kinds of possible danger. Potential choking risk exists when children play with plastic bags!
- If necessary, retain the original package for future transportation.

Recycling and Disposal



This product cannot be disposed of as household waste. To prevent damage to the environment, this product should be recycled. Please use the relevant recycling systems available to you or contract the distributor or manufacturer for recycling assistance.

Limited Warranty

This limited warranty covers defects in material or workmanship in new products. This warranty extends to the original purchaser only and is non-transferable. Only consumers purchasing products from authorized retailers or resellers may benefit from our limited warranty.

What is Covered?

The limited warranty covers our products against defects in material or workmanship as follows.

Height Adjustable Desk Frames

All height-adjustable desks feature a 5-year warranty for the frame & motor and a 2-year warranty for the controller, switch, electronics and other mechanisms.

Sit-Stand Desktop Workstations

All sit-stand desktop workstations feature a 5-year warranty for the frame and MDF desktop and 3-year warranty for the gas spring system and other mechanisms.

Desk Bikes

All desk bikes and parts, including the frame, electronics, and other mechanisms, feature a 1-year warranty.

Mini Steppers

All Mini Steppers feature a 3-year warranty.

Monitor Mounts

All monitor mounts and parts, including arms, gas spring systems and other mechanisms, feature a 5-year warranty.

What are your Remedies?

We will replace at no charge to the consumer the defective parts only or, at our options, replace any product or part of the product that is defective because of improper workmanship and/or material, under normal installation, use, service and maintenance. If we are unable to provide a replacement and repair is not practical or cannot be completed in a timely fashion, we may elect to refund the purchase price in exchange for the return of the product. In the rare even that your product is defective, we will provide you with a replacement item shipped at no cost to you within the continental United States. The shipping method for replacement products is FedEx Ground, but expedited shipping is available if you choose to pay the additional expense. In addition, you will need to pay the shipping costs if any products need to be shipped to you at an address outside the continental United States.

REPAIR OR REPLACEMENT (OR, IN LIMITED CIRCUMSTANCES, REFUND OF THE PURCHASE PRICE) AS PROVIDED UNDER THIS WARRANTY IS THE EXCLUSIVE REMEDY OF THE PURCHASER. FLEXISPOT NEITHER ASSUMES NOR AUTHORIZES ANY PERSON TO CREATE FOR ANY OTHER OBLIGATION OR LIABILITY IN CONNECTION WITH THIS PRODUCT.