

Aluminium Greenhouse

ASSEMBLY INSTRUCTIONS

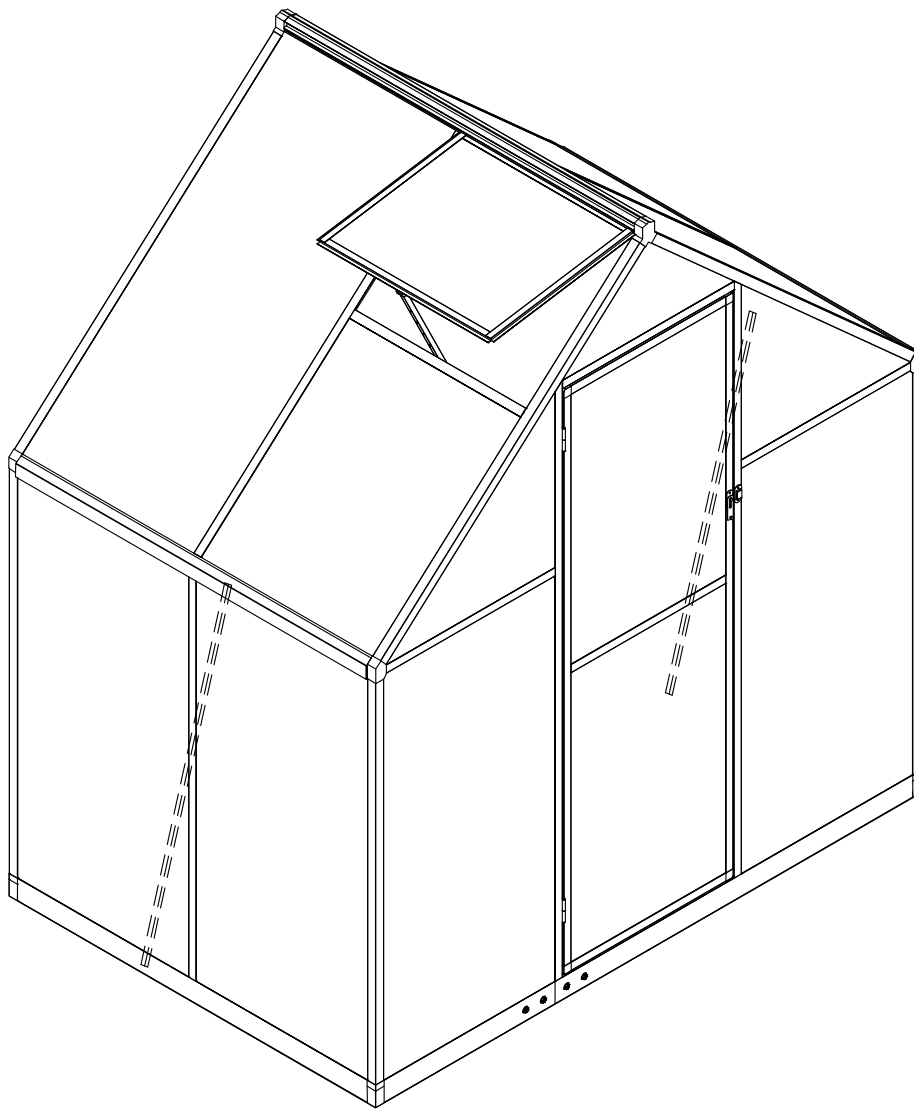

VIWAT@cnrrx.net

Please read all instructions carefully before assembly.
It is best to familiarize yourself with the parts and
collate the appropriate parts for each step.

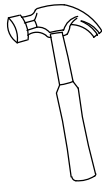
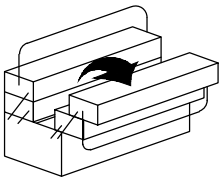

Aluminum Parts :

No.	Picture	Qty.
A1-1		x2
A1-2		x2
A1-3		x2
A2		x2
A3		x1
A4		x4
A5-1		x1
A5-2		x2
A5-3		x1
A6-1		x1

No.	Picture	Qty.
A6-2		x1
A6-3		x1
A6-4		x1
A7		x1
A8		x1
A9-1		x1
A9-2		x1
A9-3		x2
A10		x4
A11		x1

Aluminum Parts:

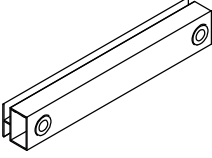
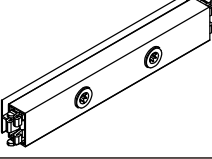
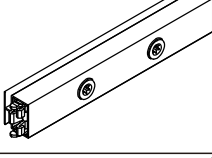
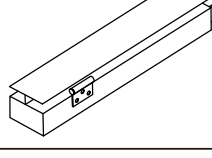
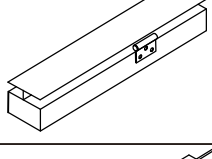
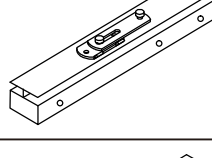
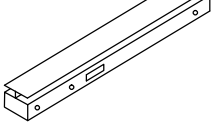
No.	Picture	Qty.
A12		x1
A13		x2
A14		x1
A15-1		x1
A15-2		x1
A15-3		x1
A15-4		x1

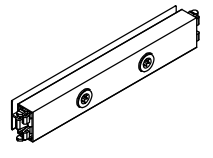
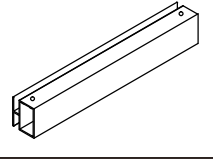
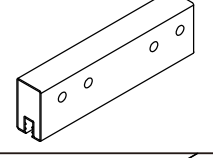
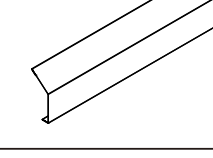
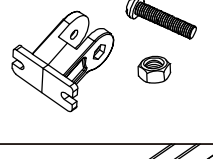
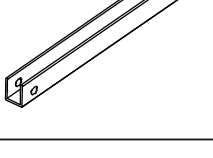
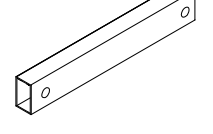
No.	Picture	Qty.
A16		x1
A17		x2
A18		x2
A21		x2
A22-1		x1
A22-2		x1
A23		x2

Plastic Parts:



No.	Picture	Qty.
H1		x4
H2		x2
H3		x2

No.	Picture	Qty.
H4		x2



Hardware:

No.	Picture	Qty.	Size
H6		x10	M6x30
H7		x1	
H8		x39	M6x12
H9		x10	M6
H11		x8	St5x10
H12		x6	St5x16
H13		x1	
H14		x1	

No.	Picture	Qty.	Size
H15		x1	
H18		x1	
H19		x1	M4X40
H20		x10	M4x8
H23		x2	
H24		x4	

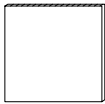
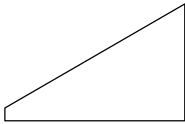
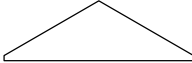
Twin PC Board:

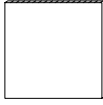
No.	Picture	Qty.
B1		12
B2		2
B3		4
B4		1

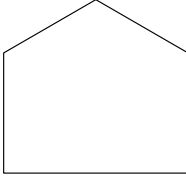
No.	Picture	Qty.
B5		1
B6		1
B7		1

The white film faces outwards if applicable.

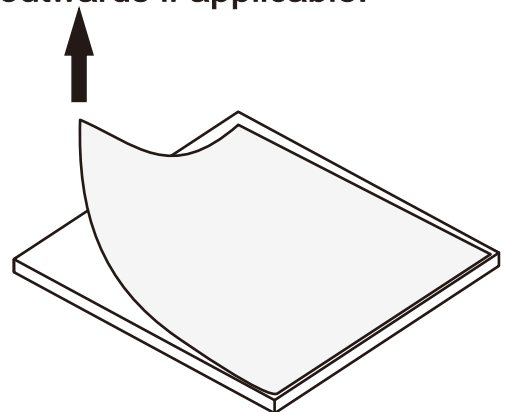

ROOF SECTION

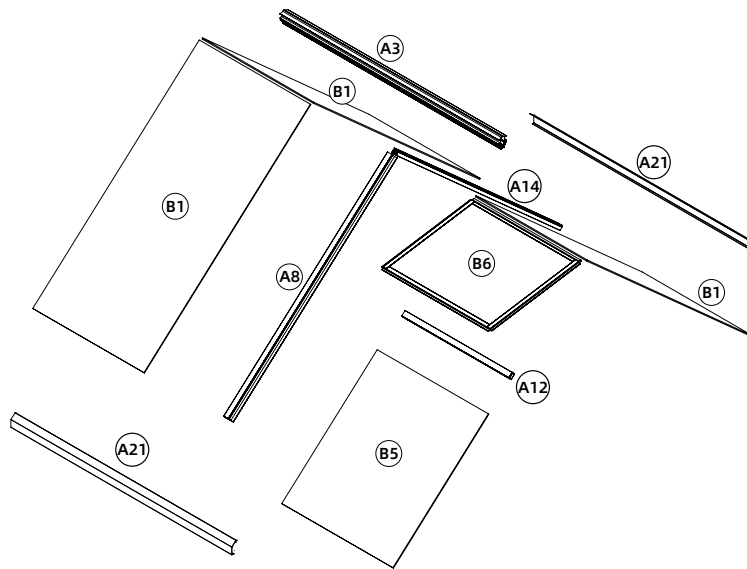

WALL SECTION

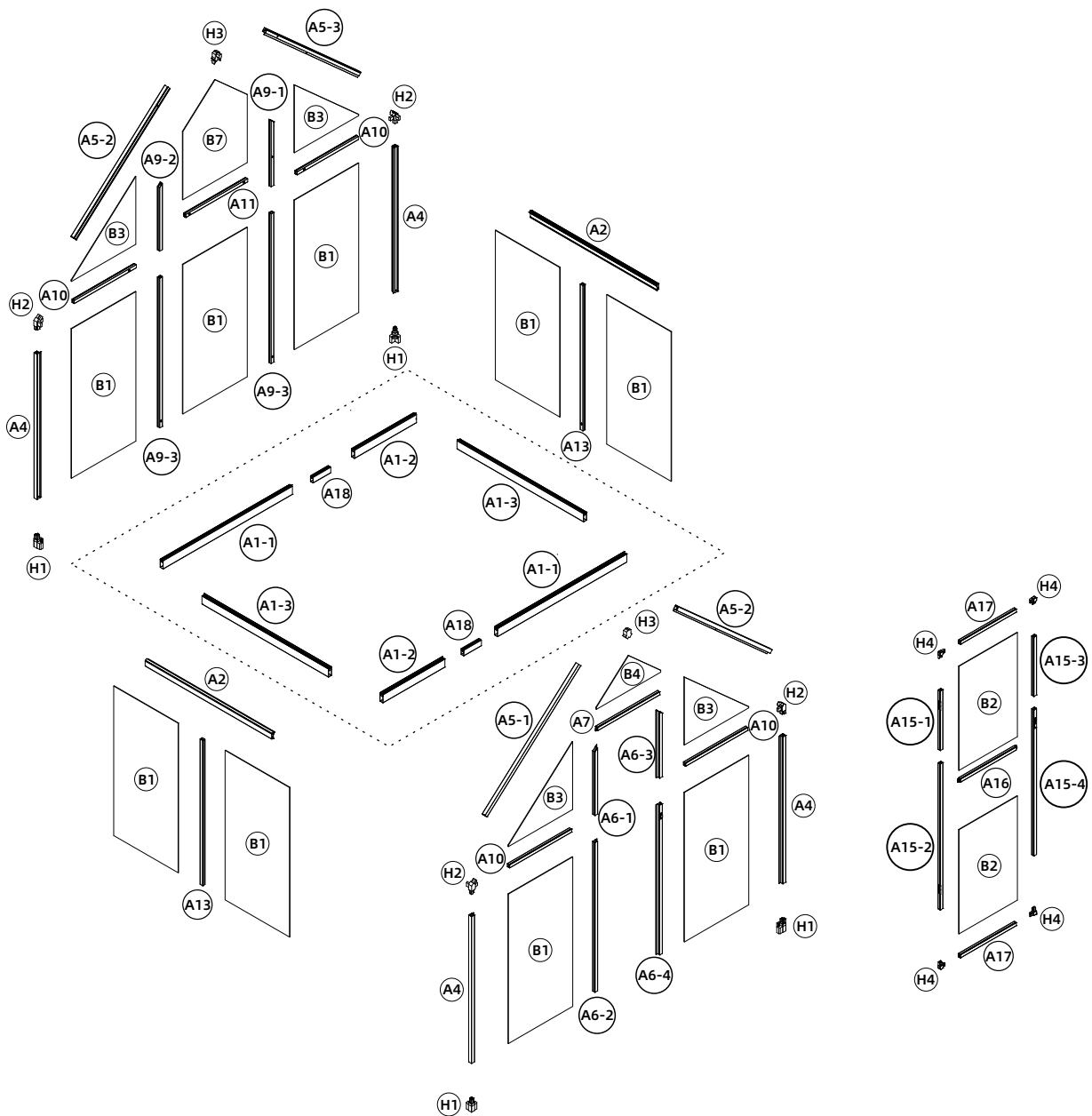

Picture	NO.	Qty.	
	A1-1	x2	
	A1-2	x2	
	A18	x2	
	M6x30	H6	x8
	M6	H9	x8

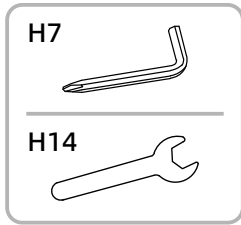

Please merge the fittings until there is no gap before tightening the screws.

Step 1

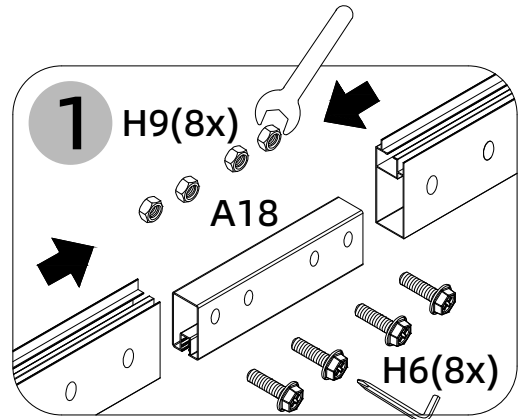
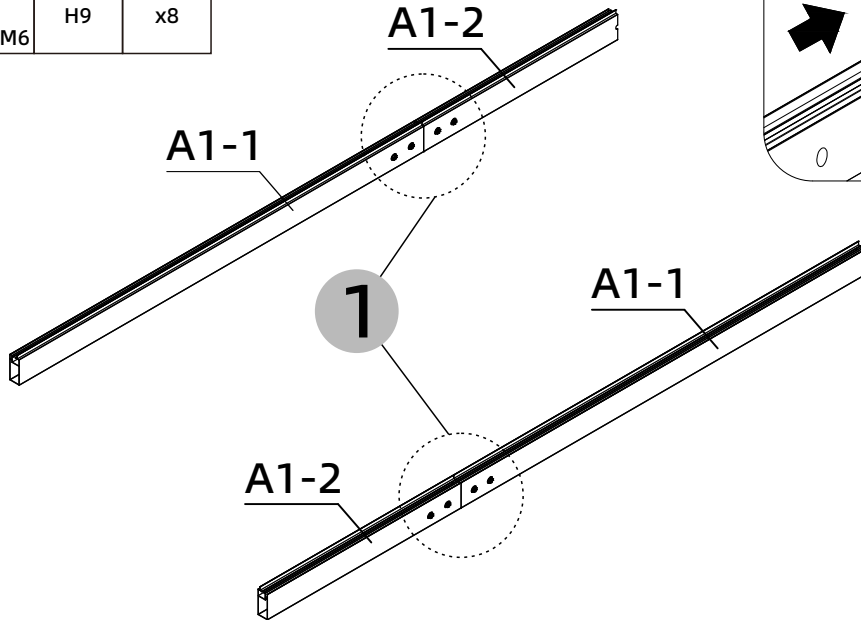

Picture	NO.	Qty.	
	A1-3	x2	
	H1	x4	
	M6x12	H8	x8

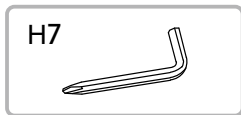

Step 2

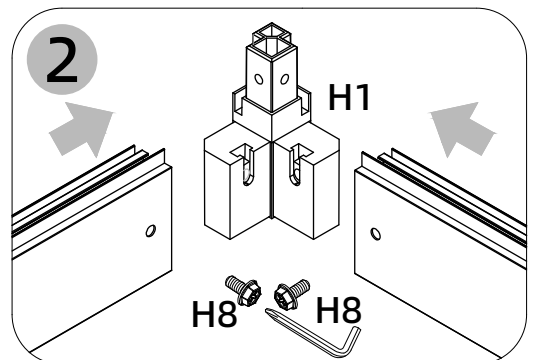
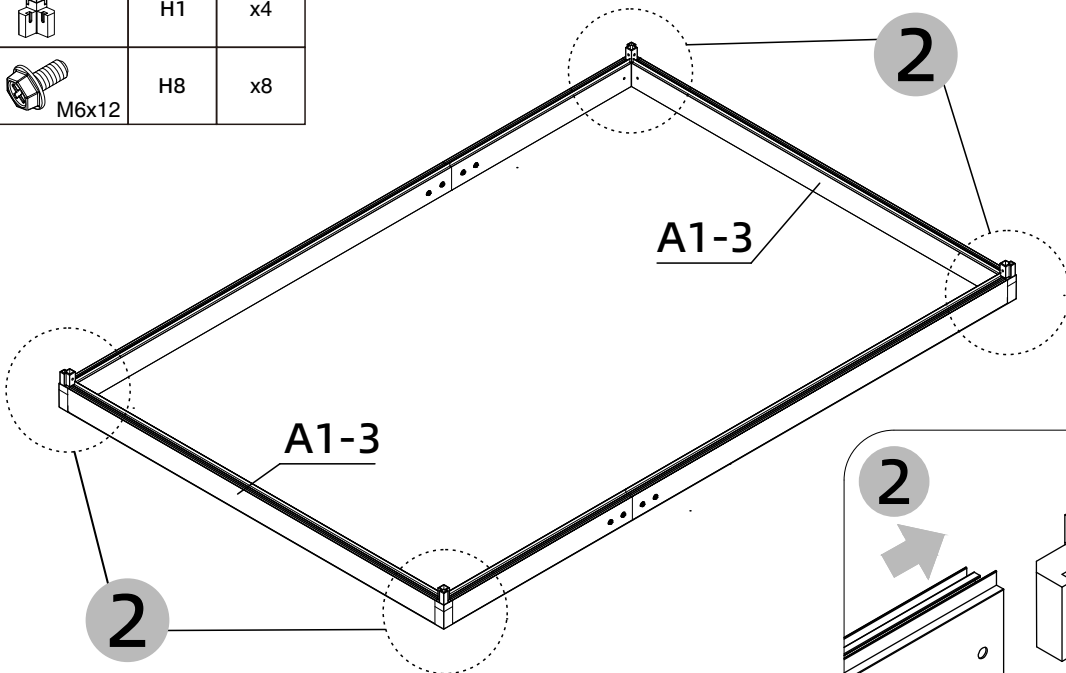

Step 3-4

Picture	NO.	Qty.
	A4	x4
	A6-1	x2
	A6-2	x2
	A6-3	x2
	A6-4	x2
	H8	x4

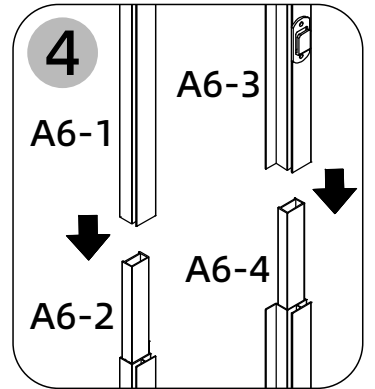
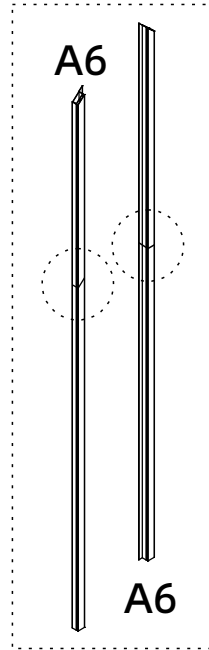
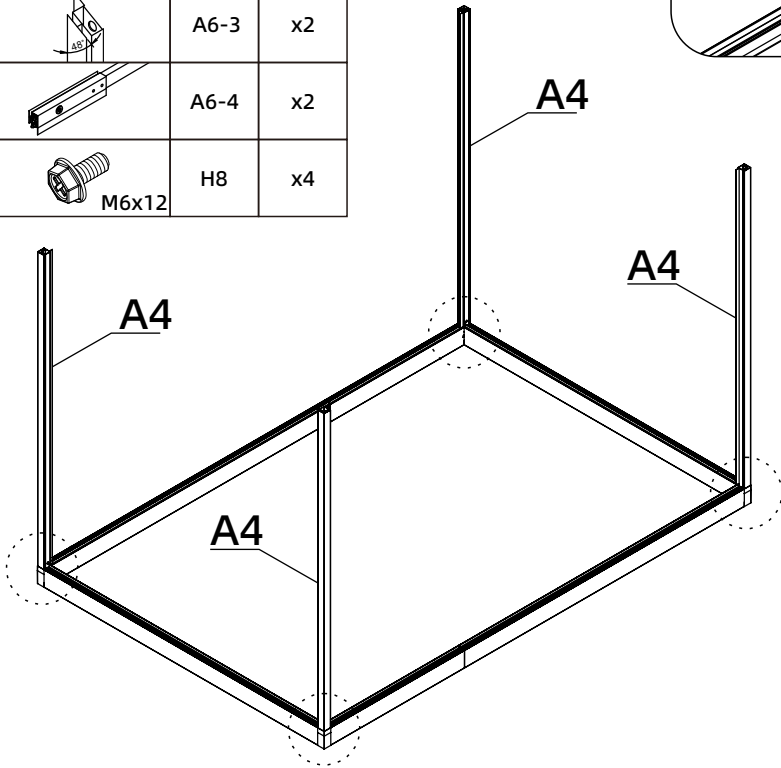
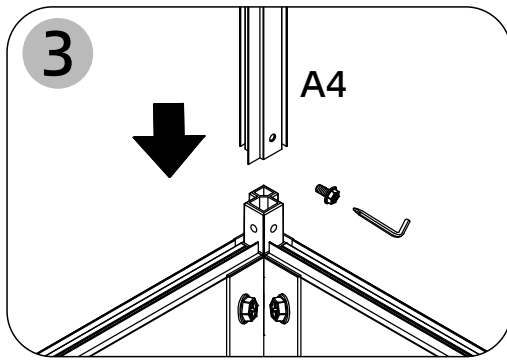
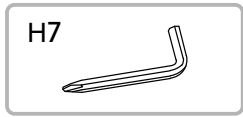

Picture	NO.	Qty.
	B1	x2



Step 5-6

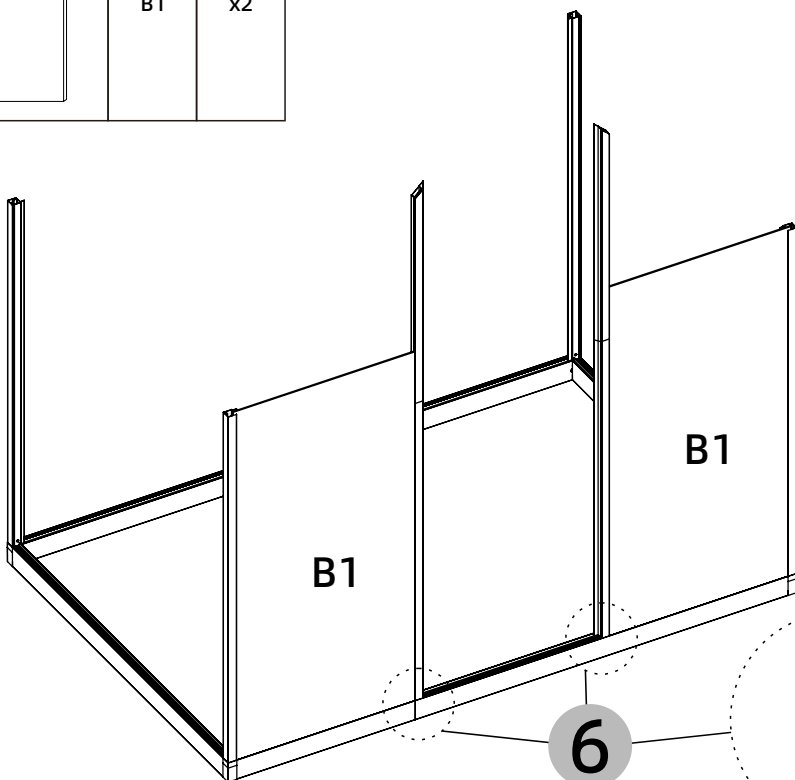
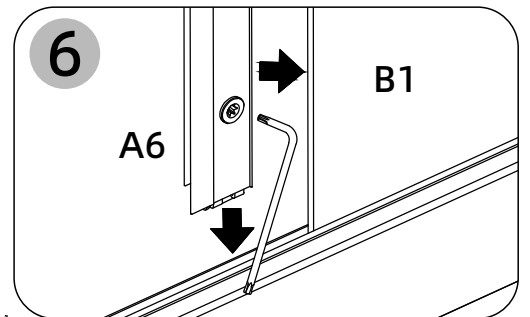
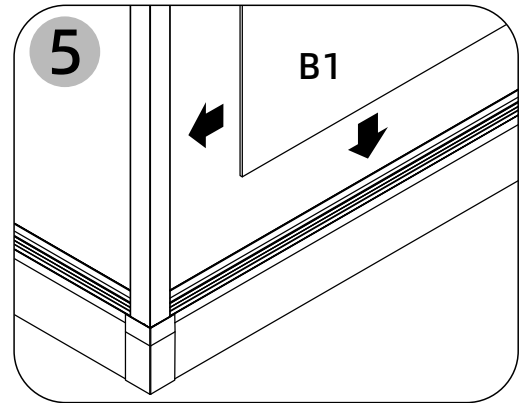

6

Step 7-9



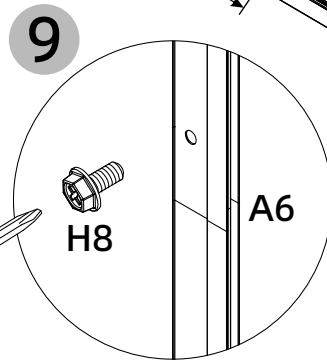
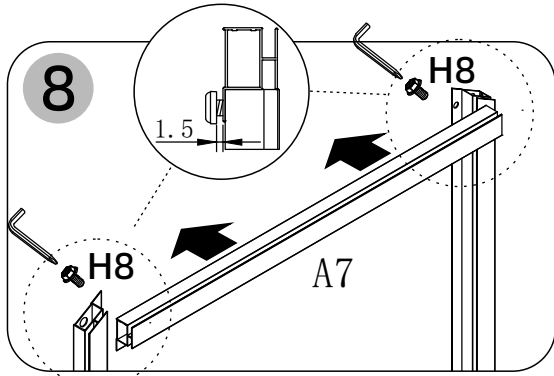
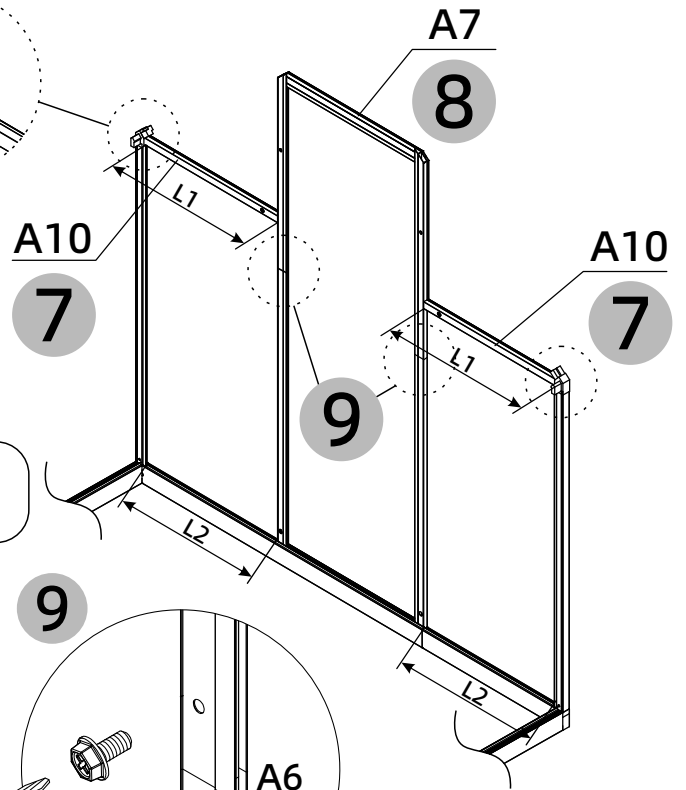
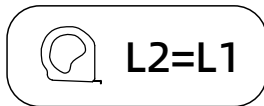
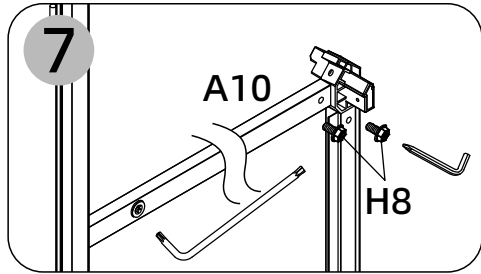
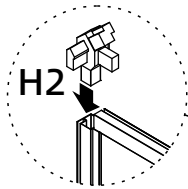
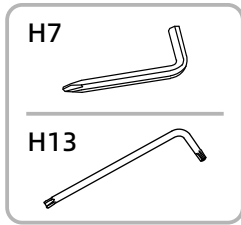

Picture	NO.	Qty.
	A7	x1
	A10	x2
	H2	x1
	H8	x8



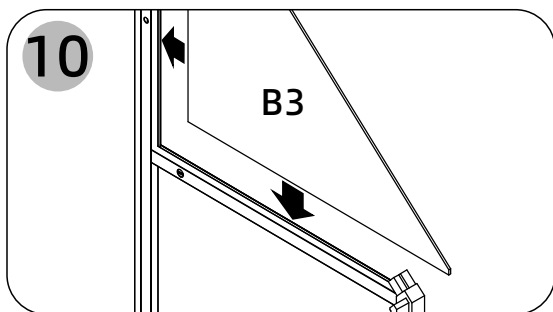
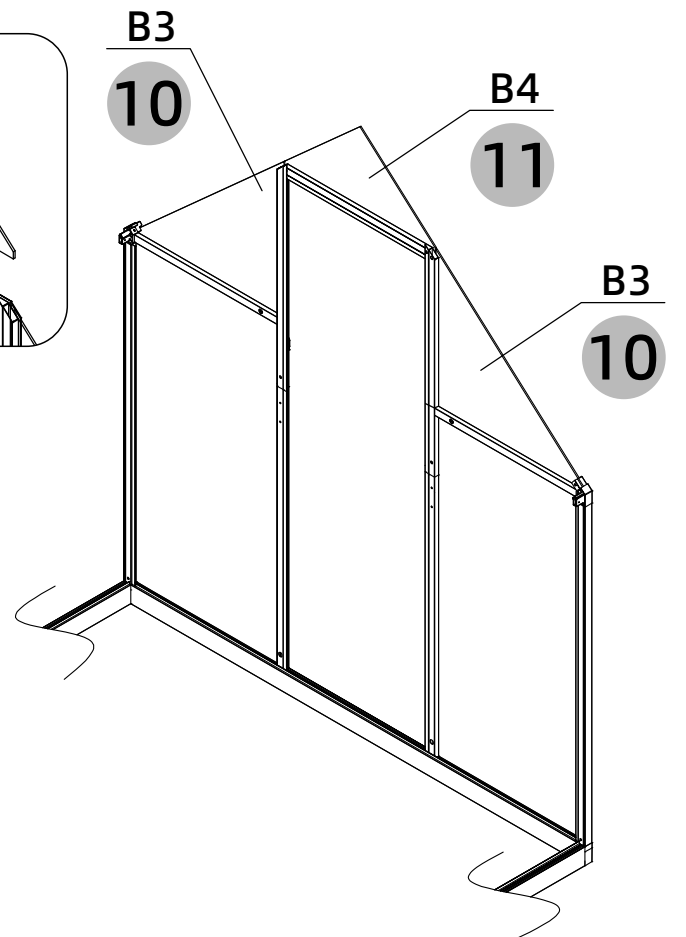
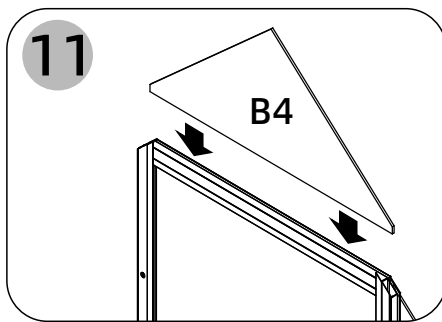

Picture	NO.	Qty.
	B3	x2
	B4	x1

Step 10-11

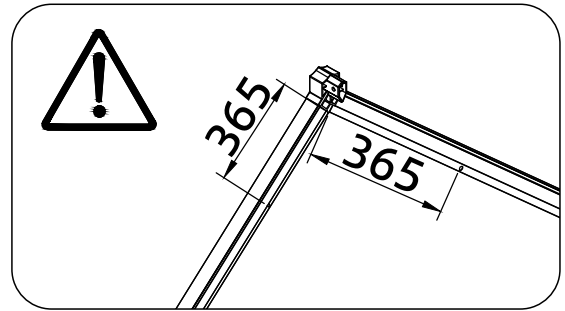
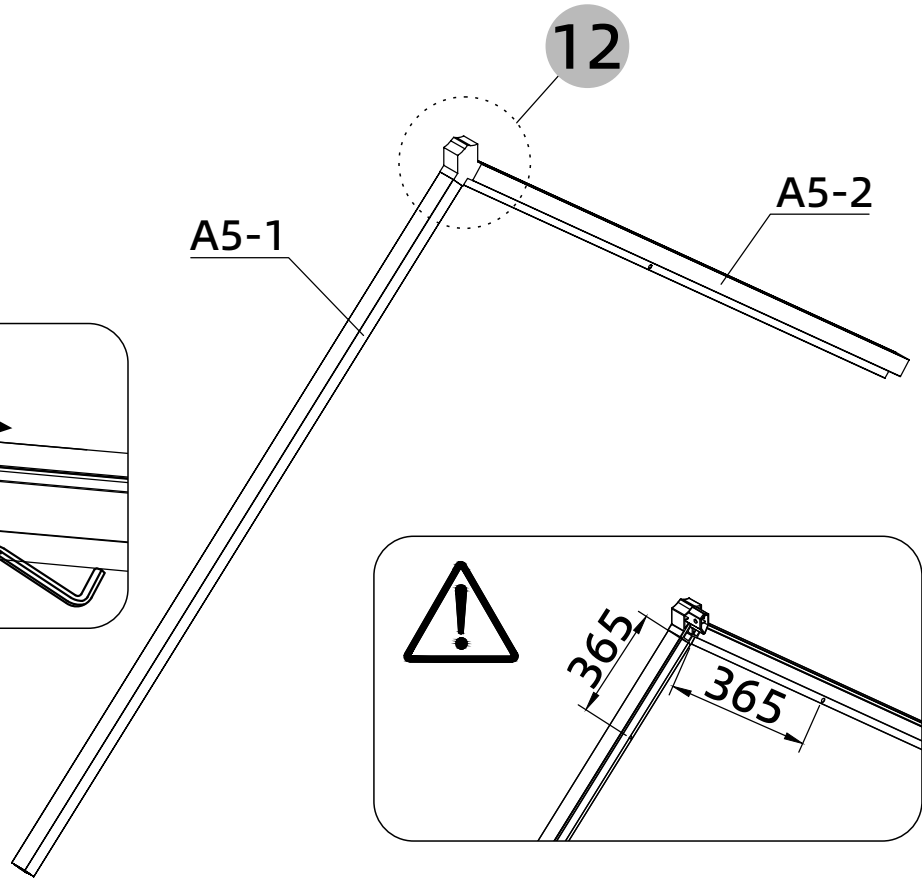
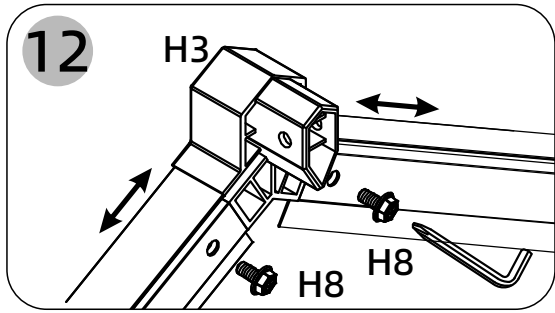
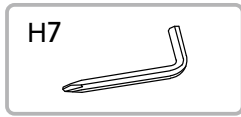

Picture	NO.	Qty.
	A5-1	x1
	A5-2	x1
	H3	x1
	H8	x2



Picture	NO.	Qty.
	H8	x4

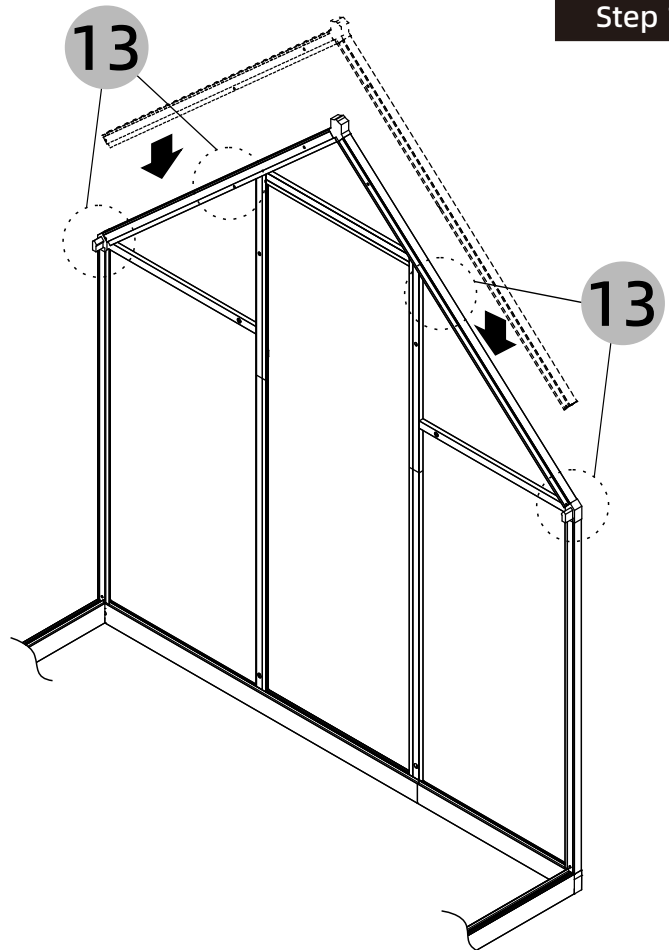
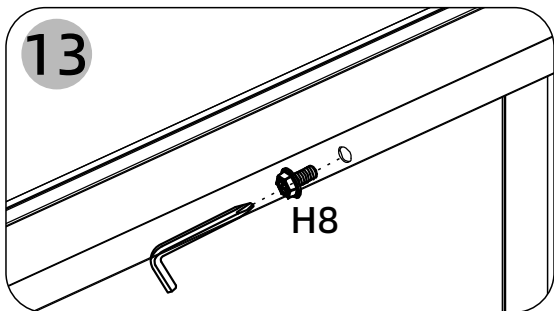
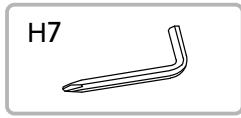

Step 14-16

Picture	NO.	Qty.
	A9-1	x1
	A9-2	x1
	A9-3	x2
	B1	x2

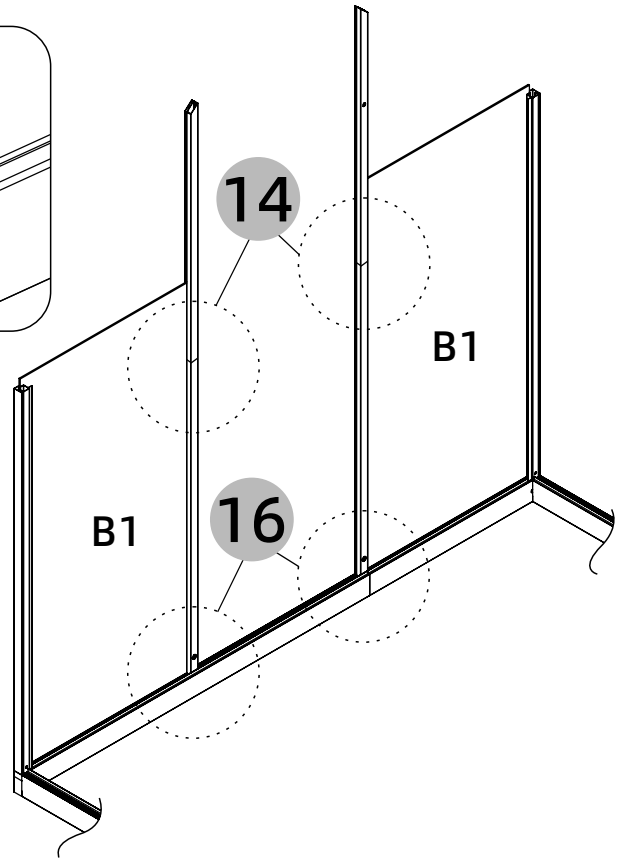
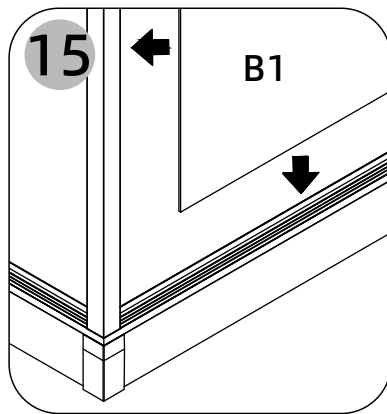
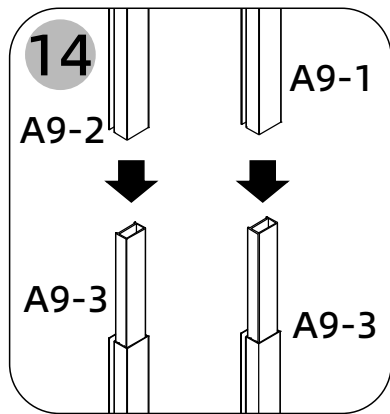
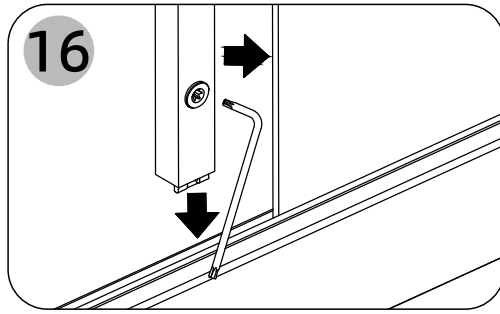
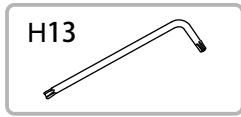

Step 17-18

Picture	NO.	Qty.
	H2	x1
	H8	x2
	B1	x1

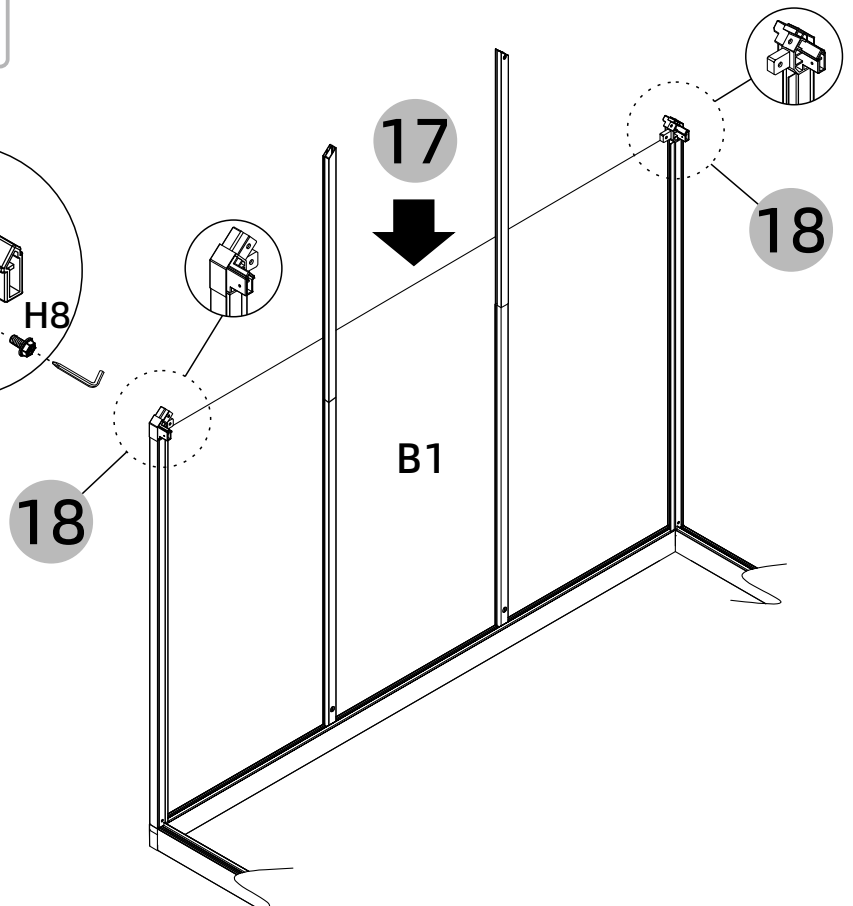
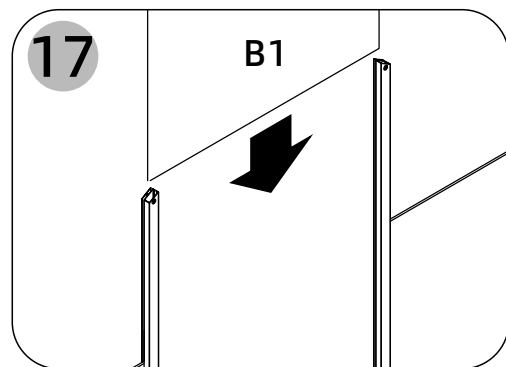
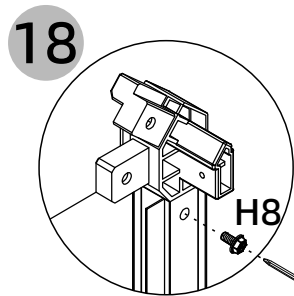

Step 19-21

Picture	NO.	Qty.
	A10	x2
	A11	x1
	H8	x4

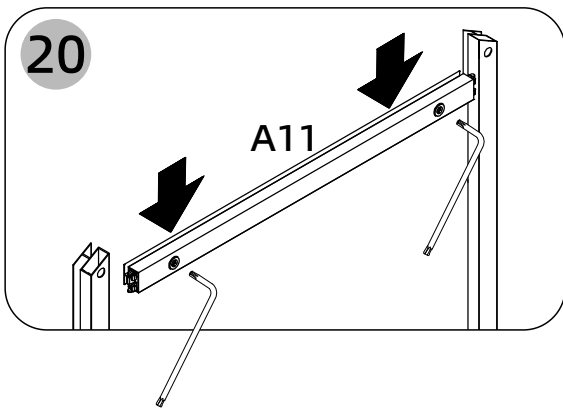
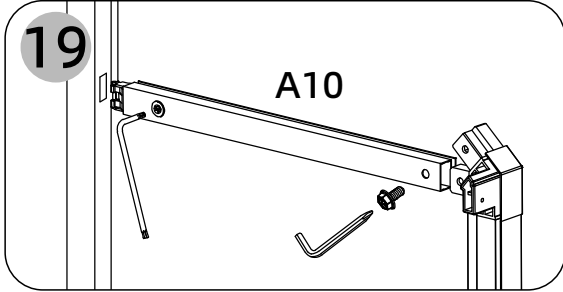
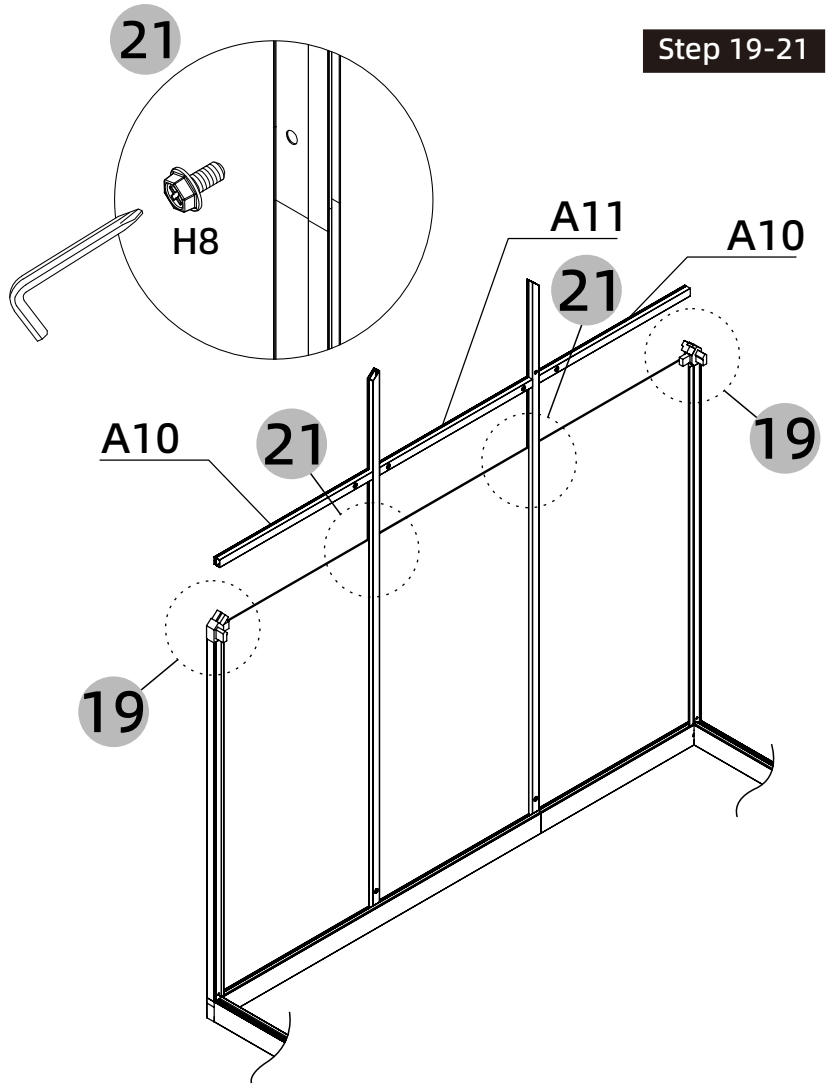
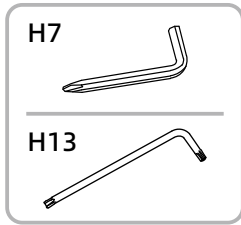

Picture	NO.	Qty.
	A5-2	x1
	A5-3	x1
	H3	x1
	H8	x2
	B3	x2
	B7	x1

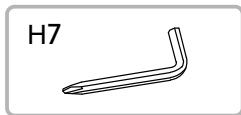



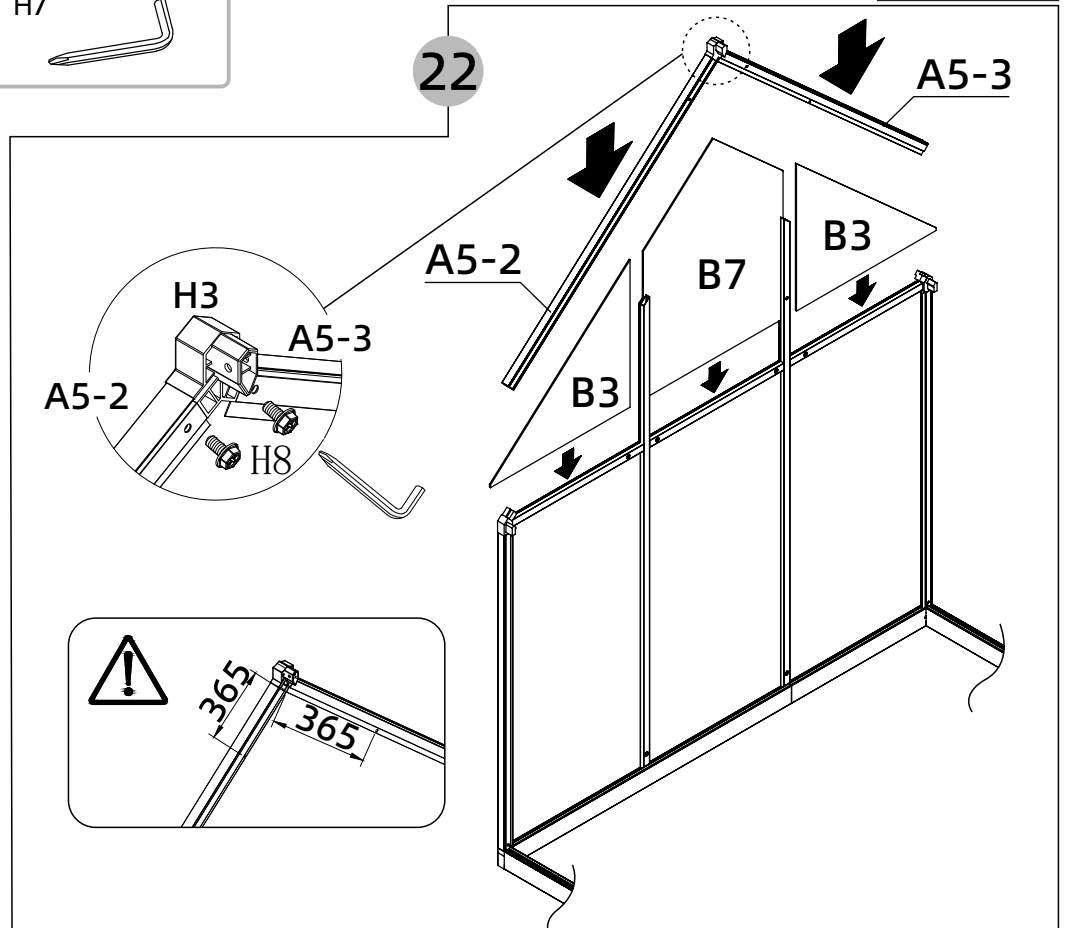

Step 22



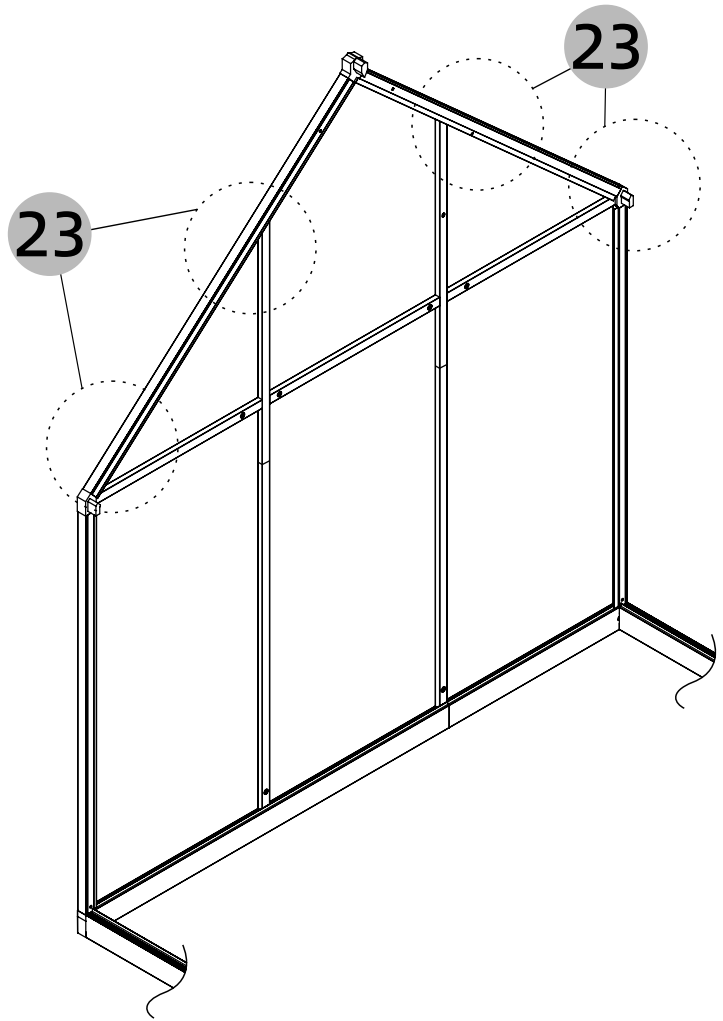
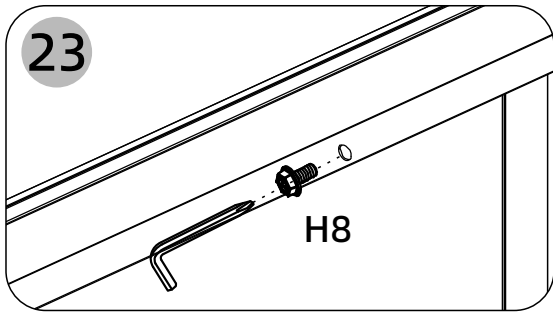
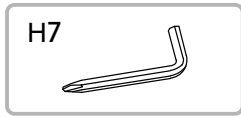

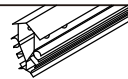
Step 23

Picture	NO.	Qty.
 M6x12	H8	x4





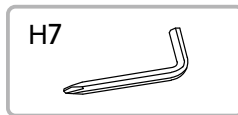

Picture	NO.	Qty.
	A3	x1
	A22-1	x1
	A22-2	x1
	H15	x1

Picture	NO.	Qty.
 M4x8	H20	x2
 window	B6	x1

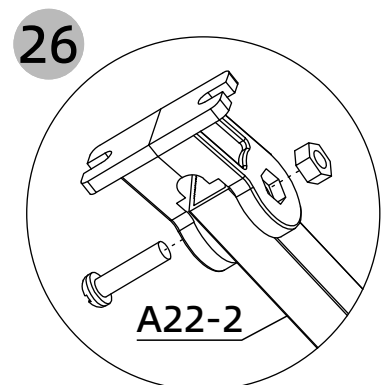
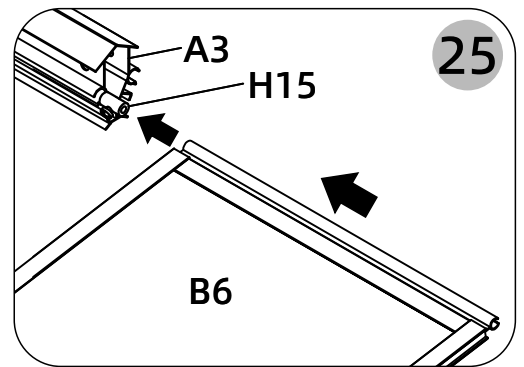
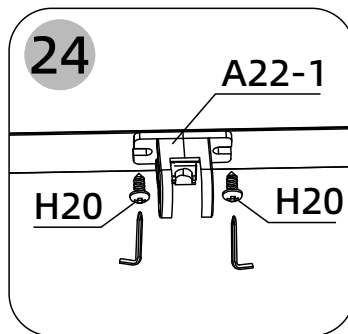
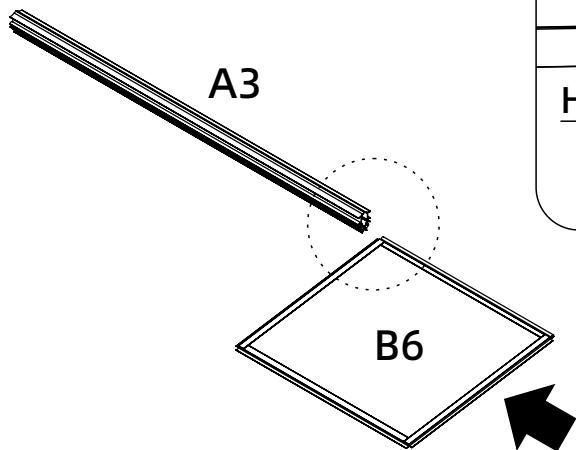

Step 24-26



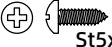

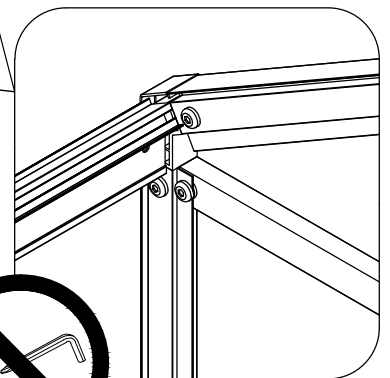
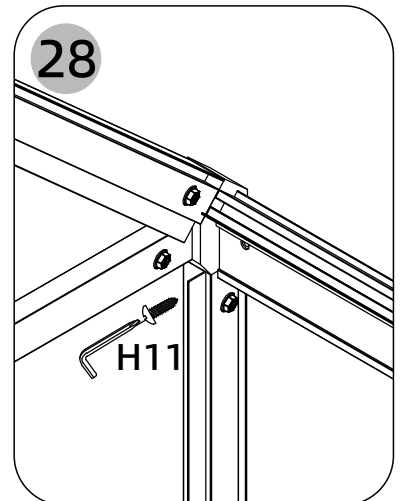
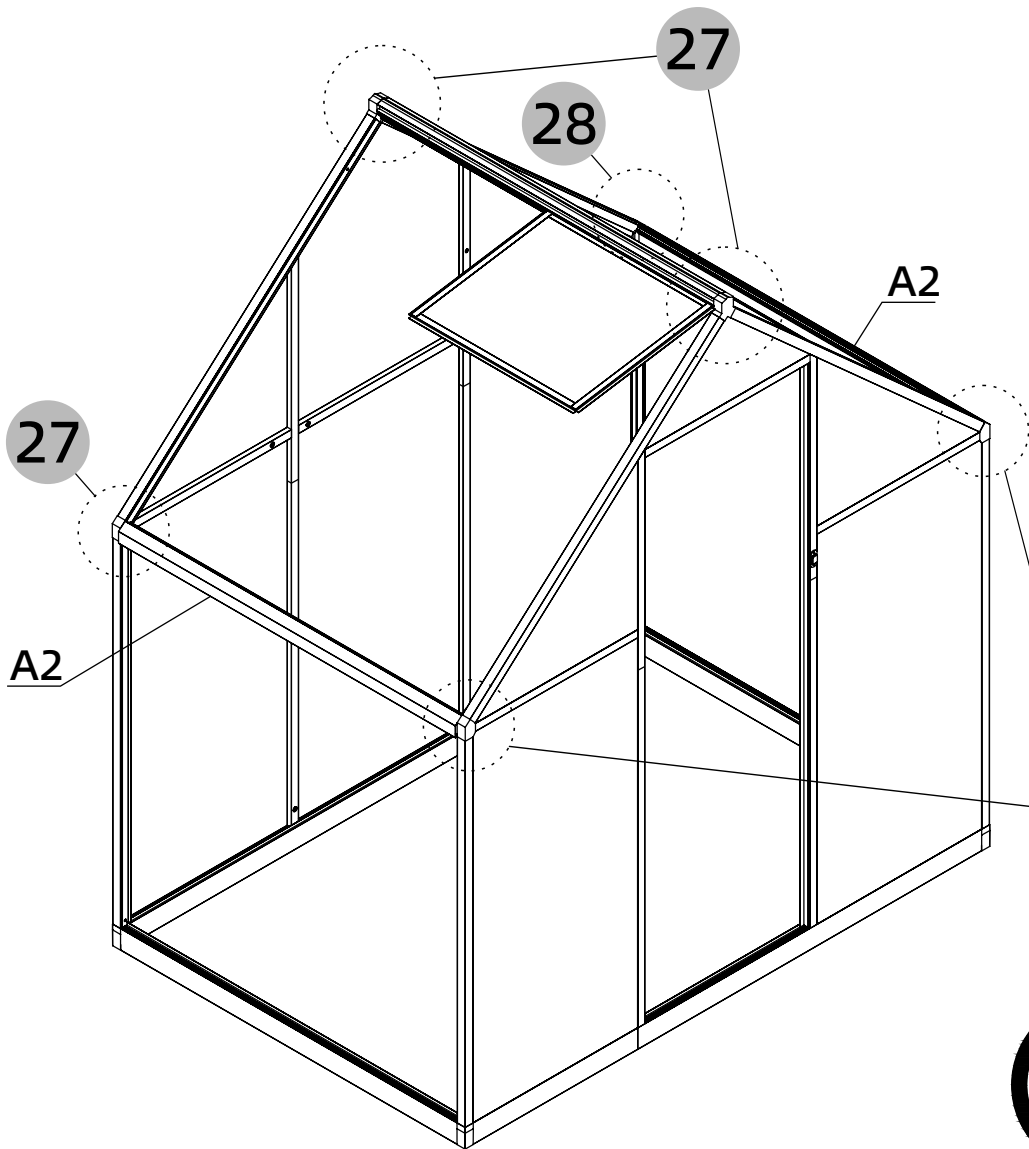
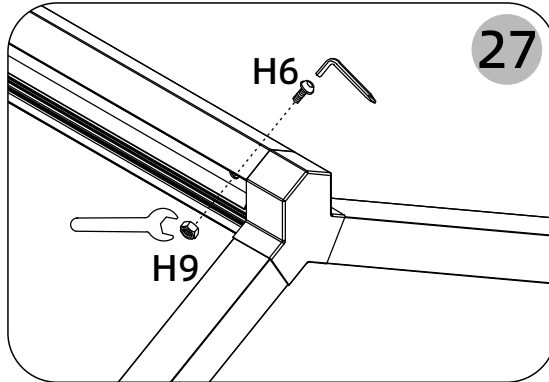
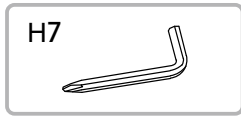
Picture	NO.	Qty.
	A2	x2
	M6x30	x2
	H9	x2
	St5x10	x2

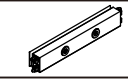
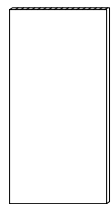

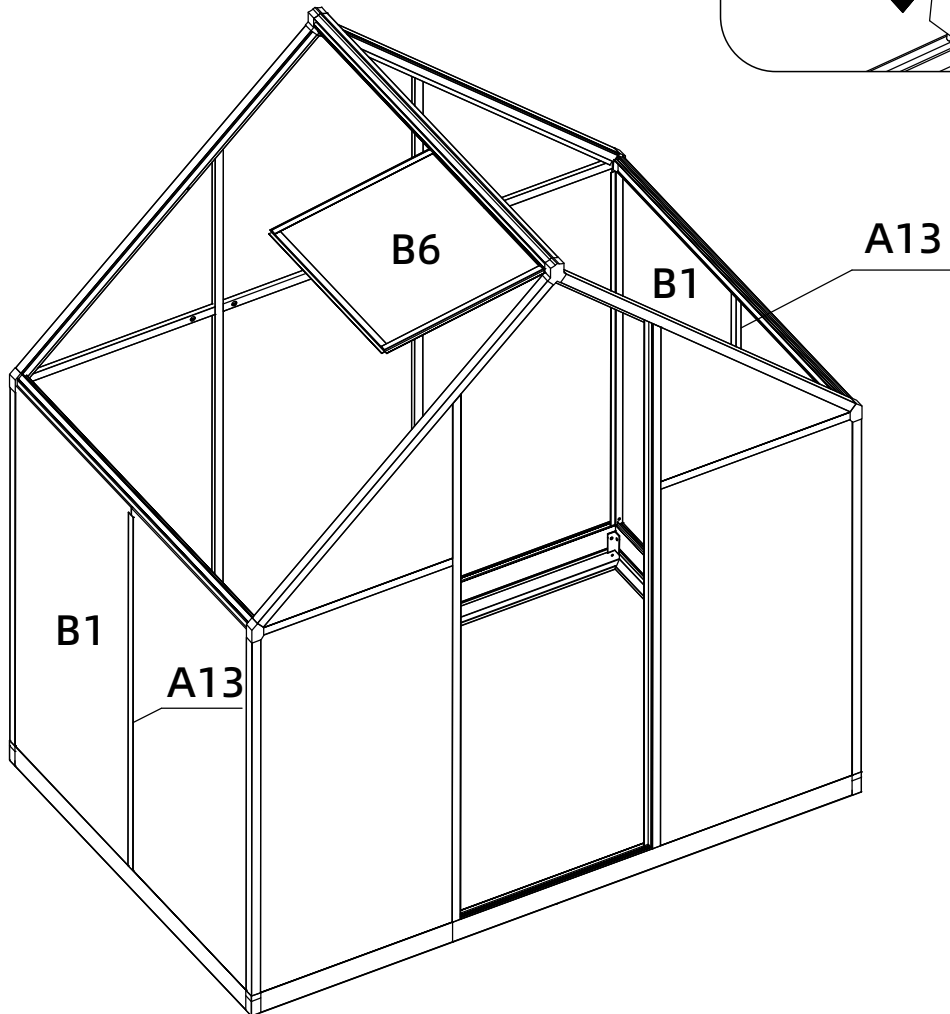
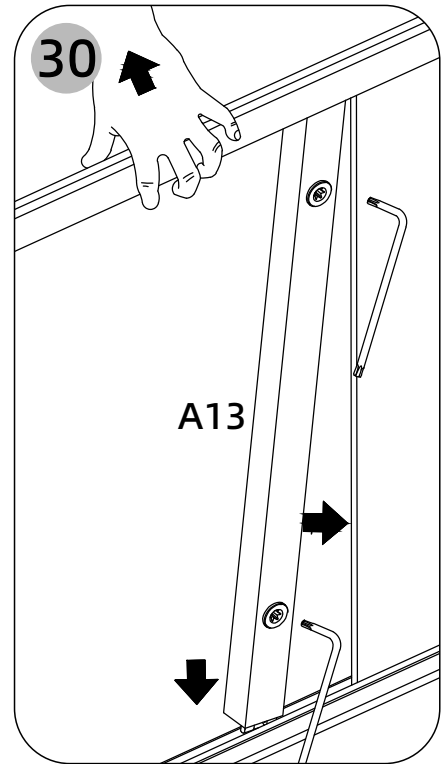
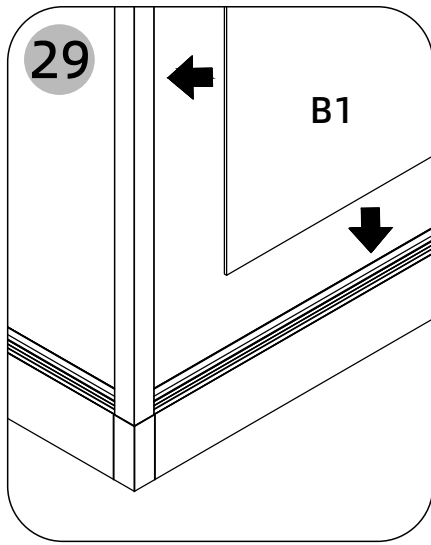
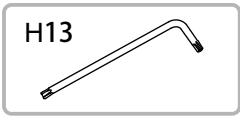

Picture	NO.	Qty.
	A13	x2
	B1	x2

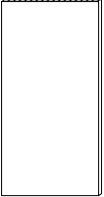

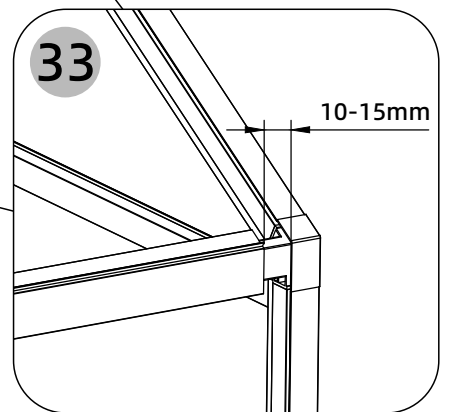
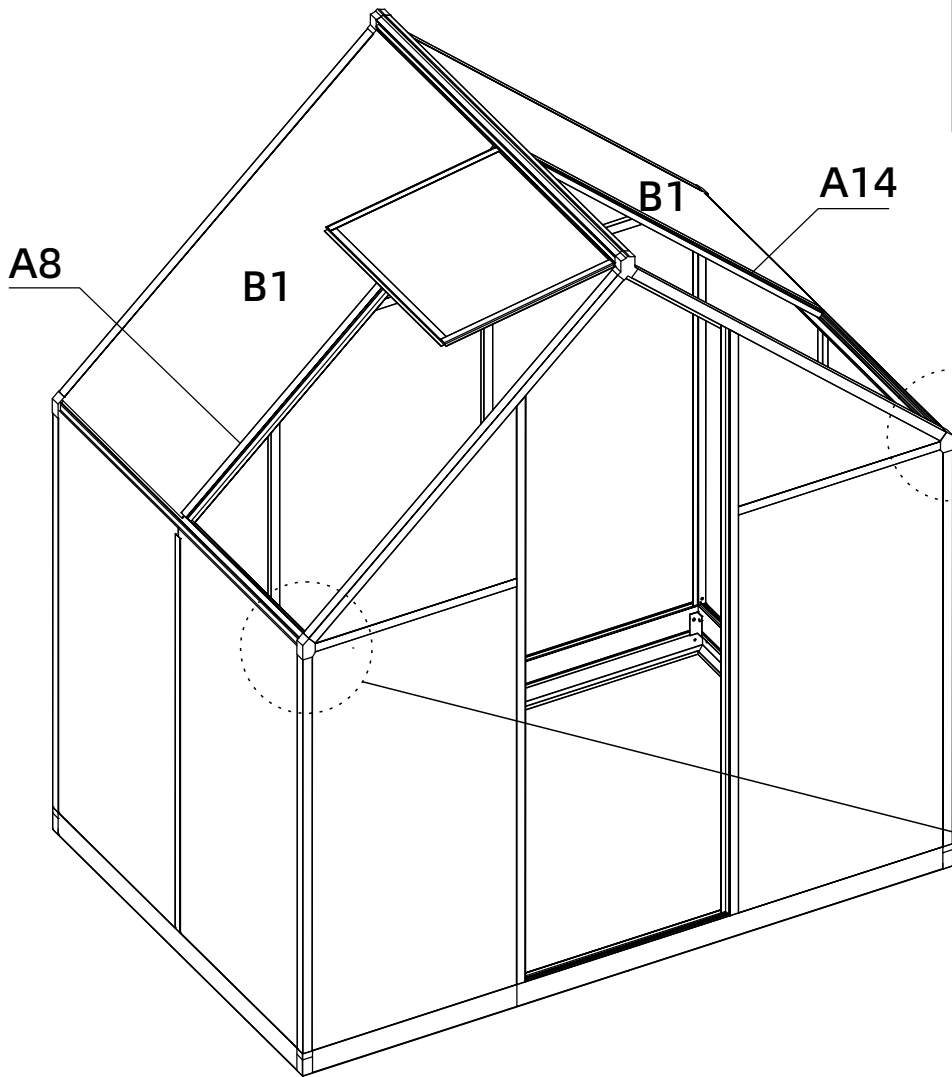
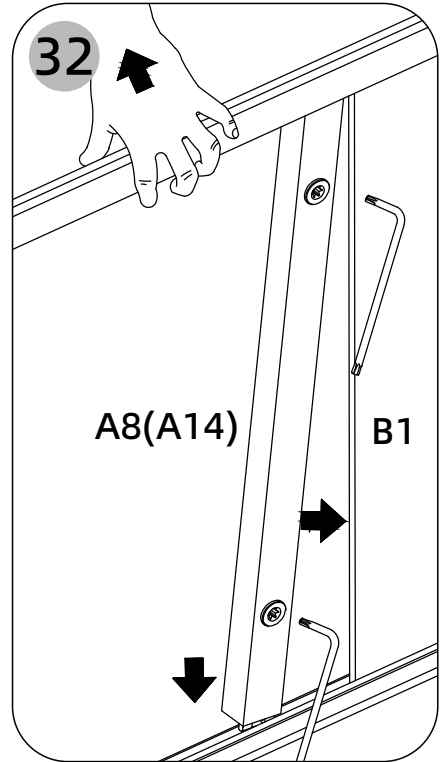
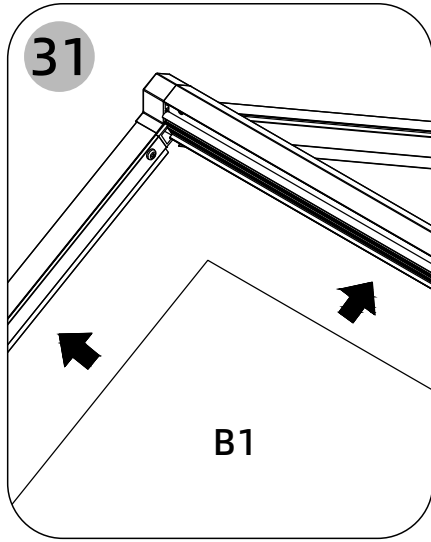
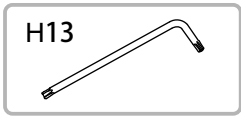

Picture	NO.	Qty.
	A8	x1
	A14	x1
	B1	x2

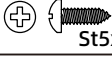
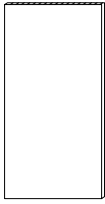
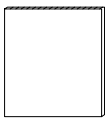

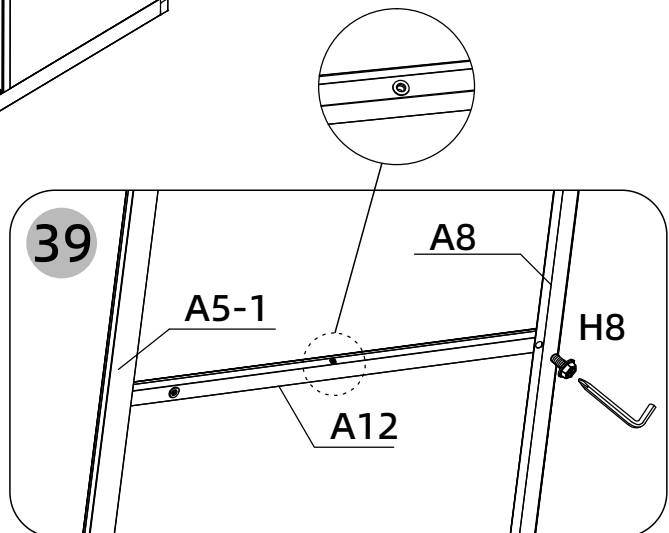
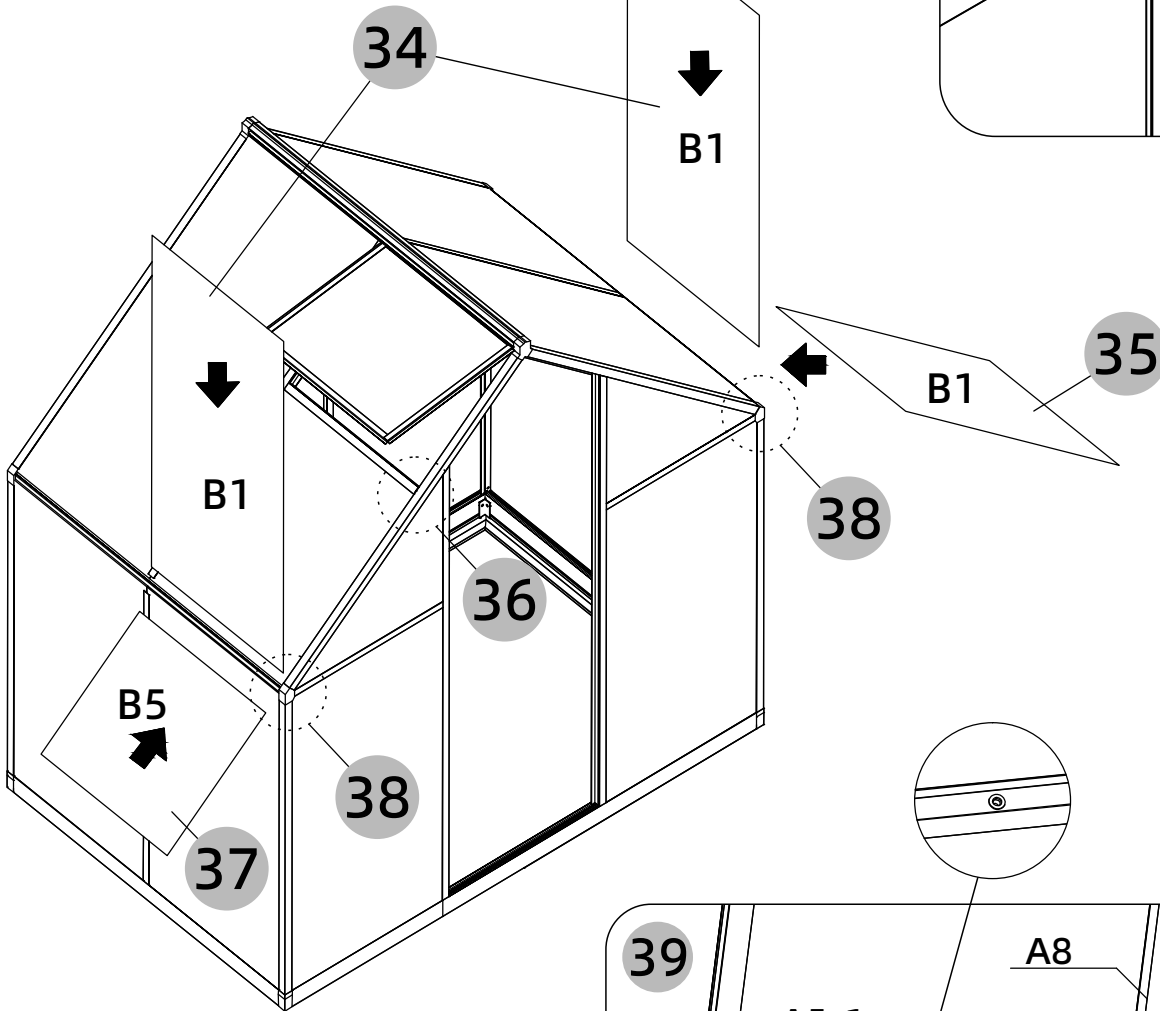
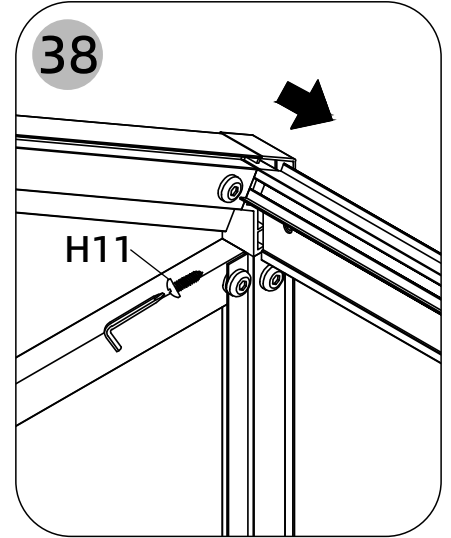
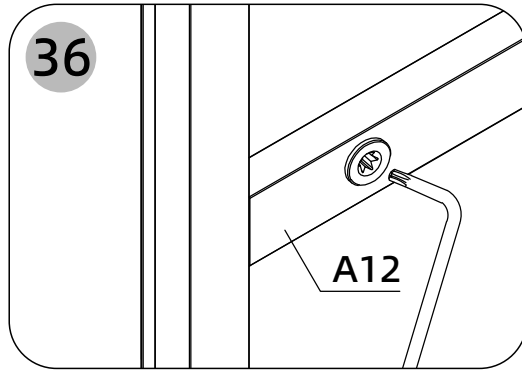
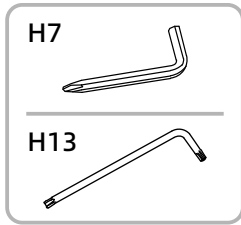

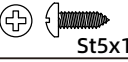
Picture	NO.	Qty.
	A12	x1
	H8	x1
	H11	x2
	B1	x3
	B5	x1

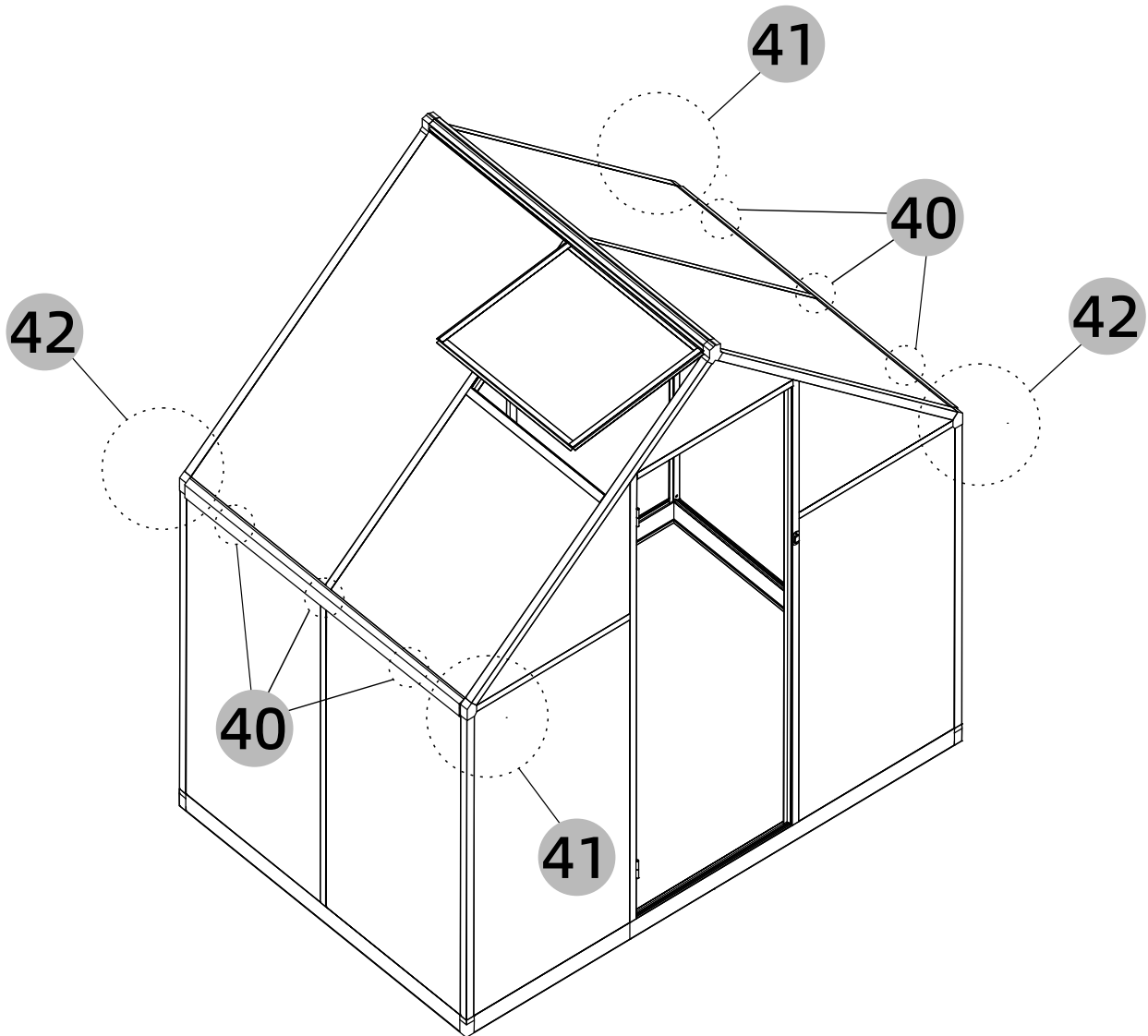
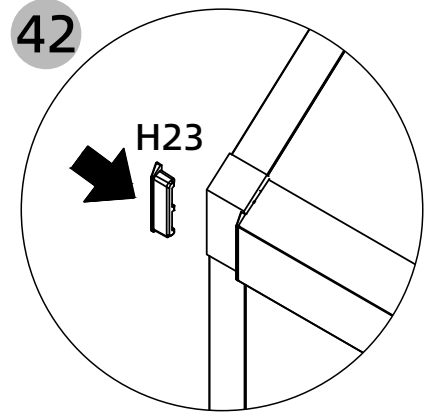
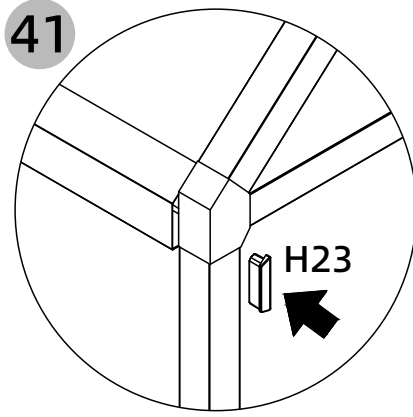
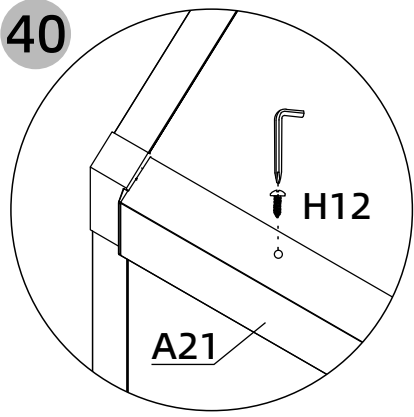
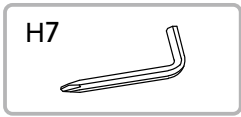

Picture	NO.	Qty.
	A21	x2
 St5x16	H12	x6
	H23	x2



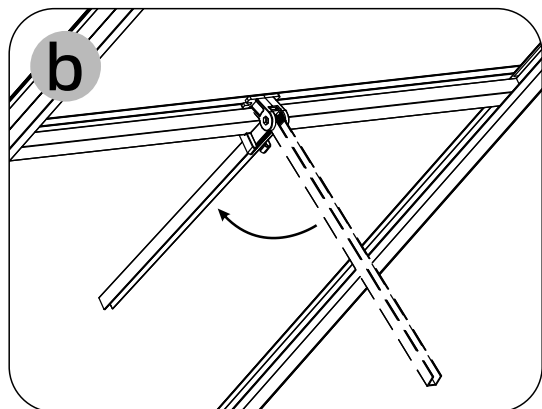
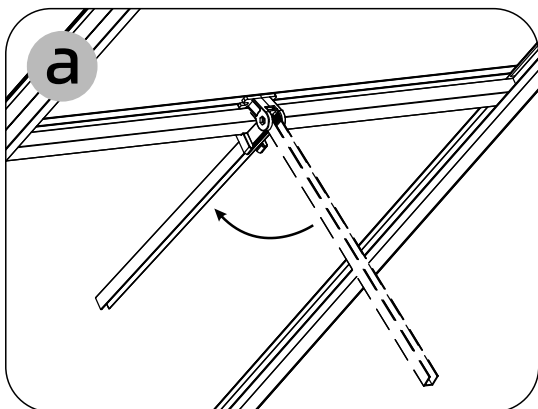
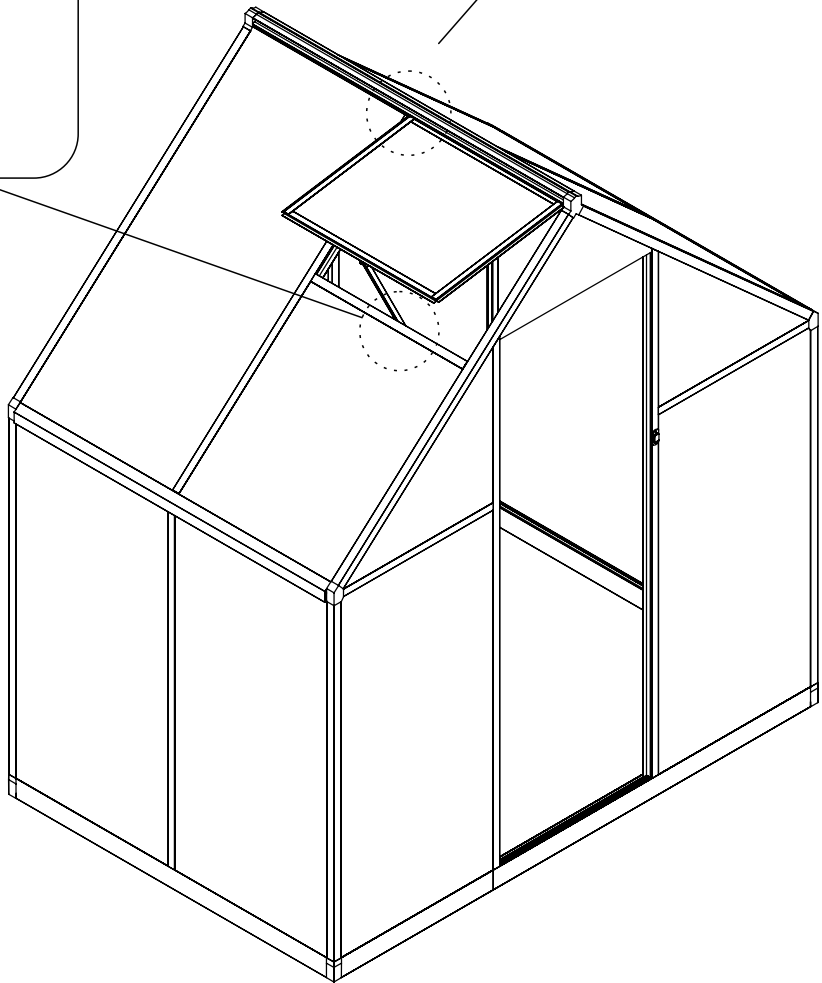
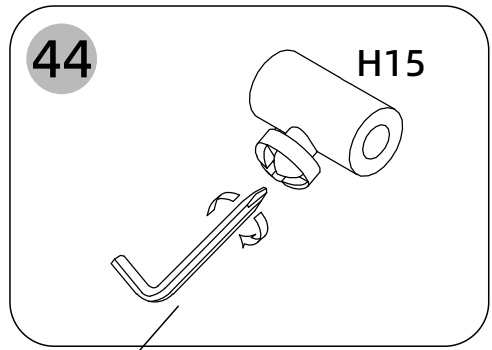
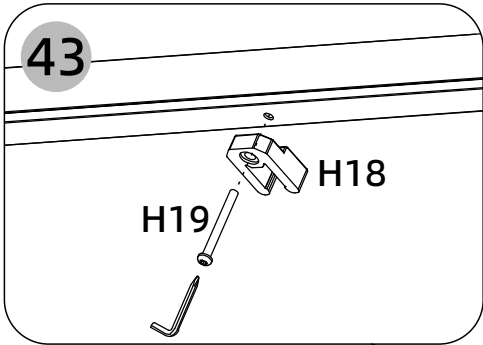
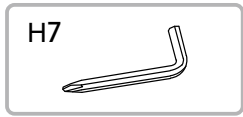

Picture	NO.	Qty.
	H18	x1
	H19	x1

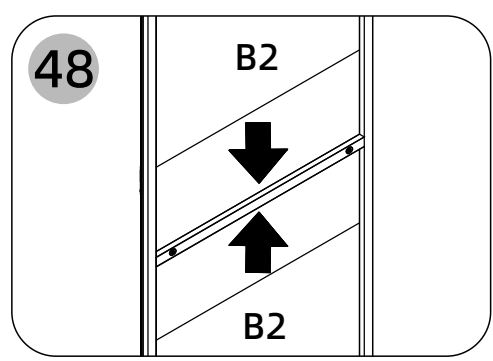
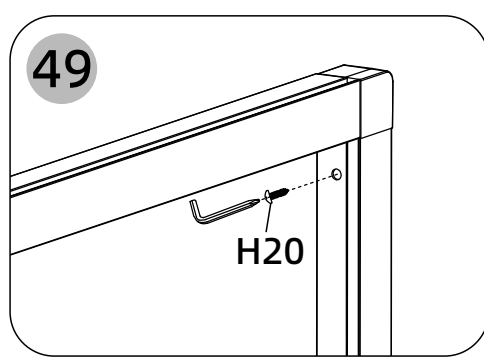
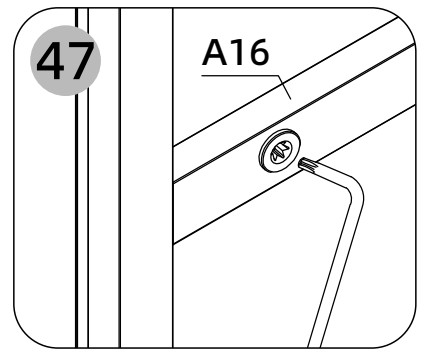
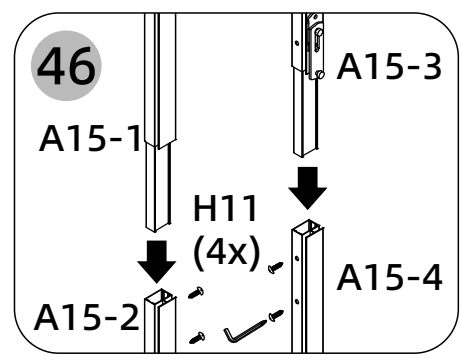
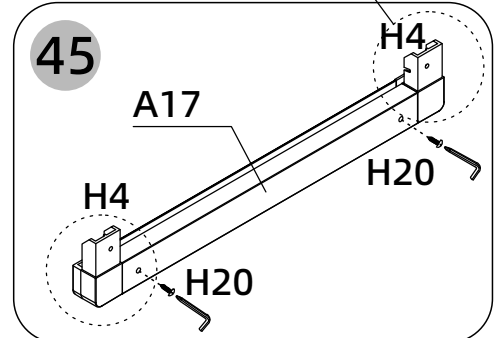
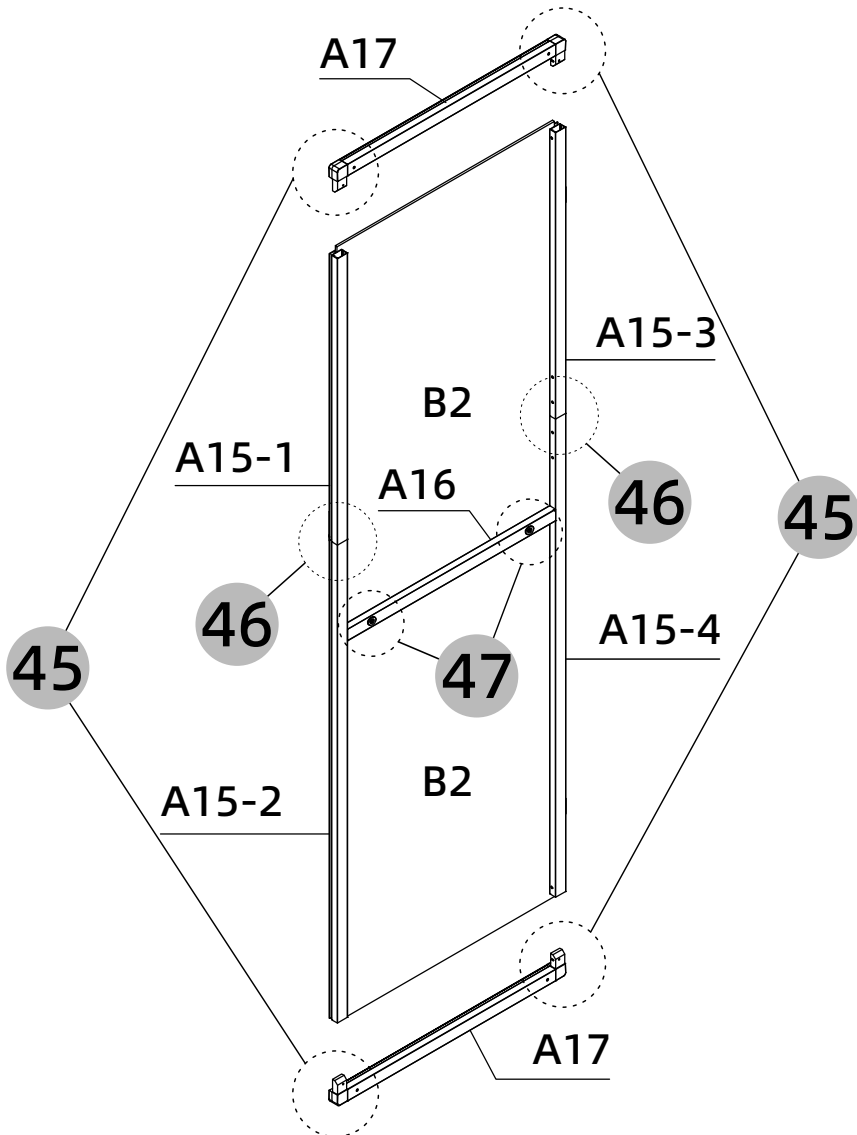
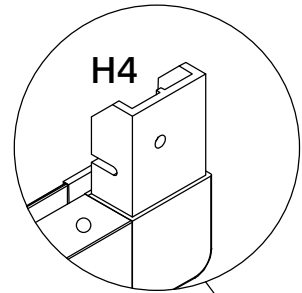
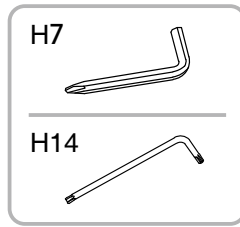

Picture	NO.	Qty.	Picture	NO.	Qty.
	A15-1	x1		H4	x2
	A15-2	x1		H11	x4
	A15-3	x1		H20	x8
	A15-4	x2		B2	x2
	A16	x1			
	A17	x2			

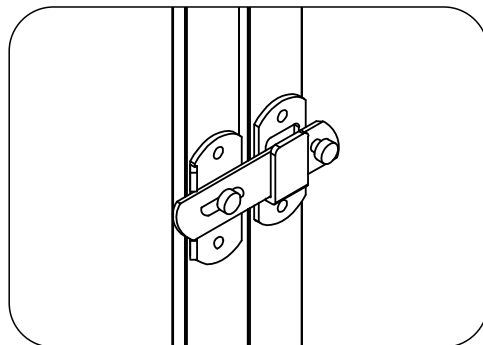
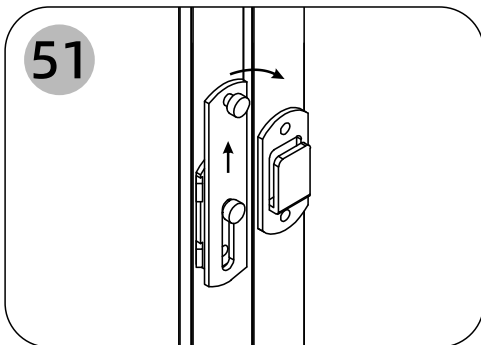
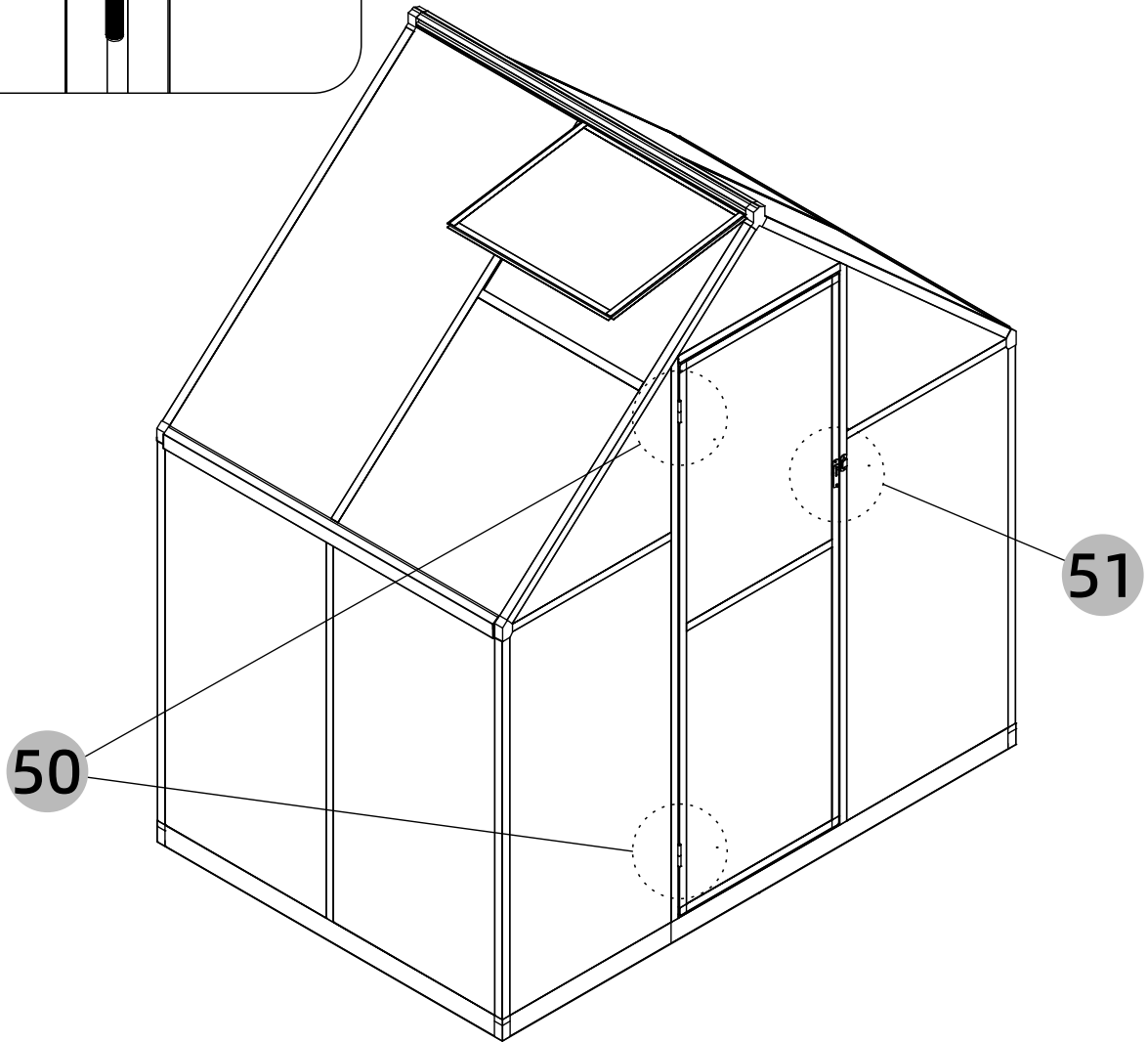
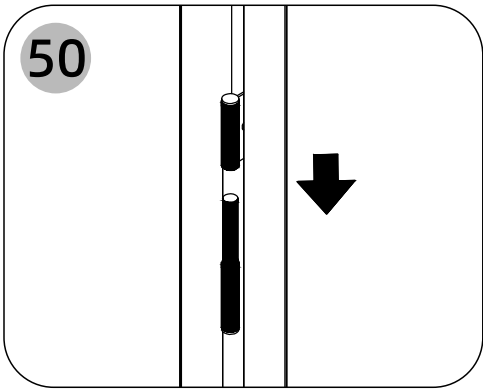



Picture	NO.	Qty.
	A23	x2
	H24	x4

