

HOME SOURCE[®]

ASSEMBLY INSTRUCTION

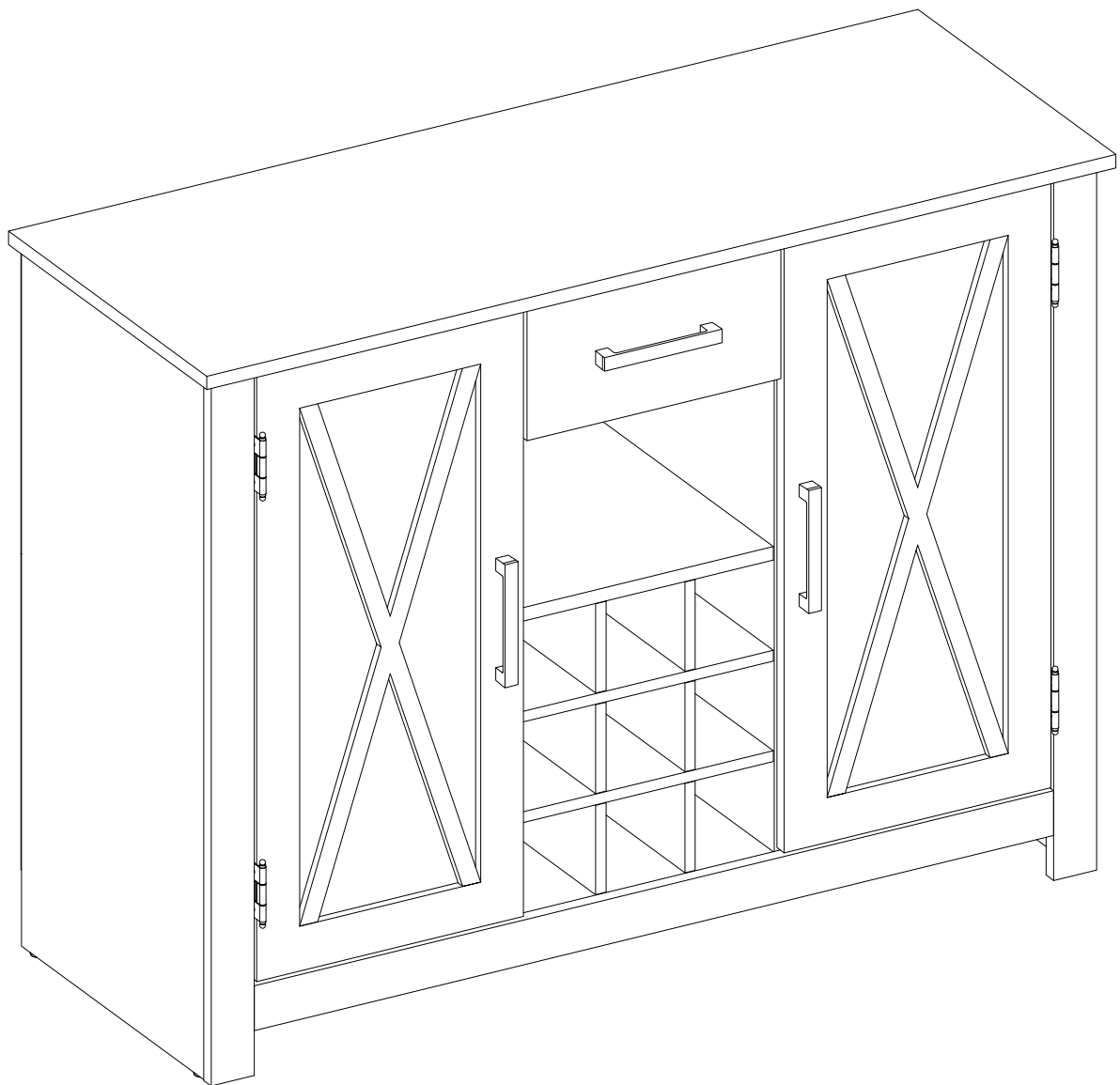





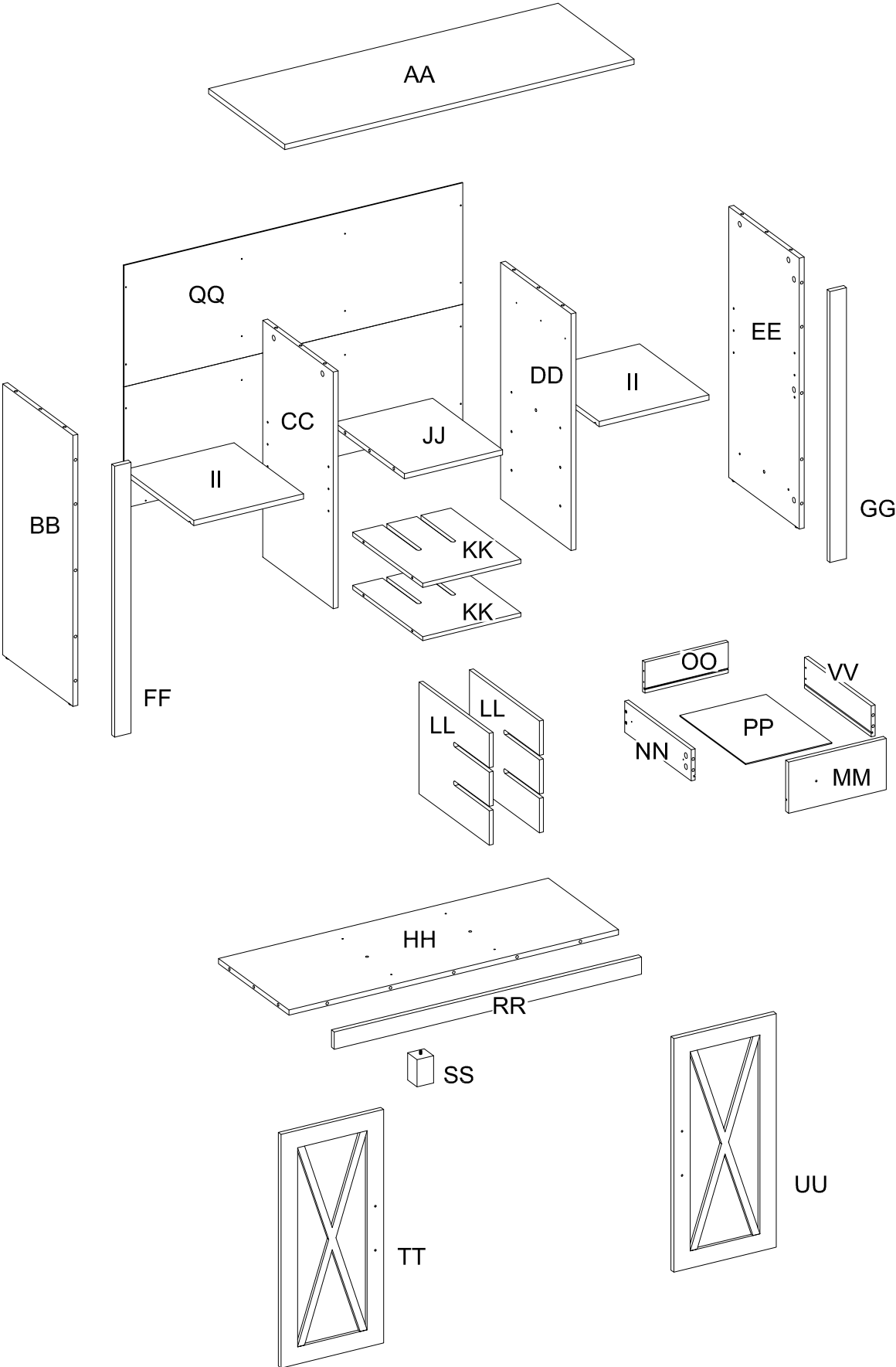











MODEL: JZ66-BASE



Parts List

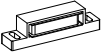

Hardware List

1		Ø6x35mm	Cam bolt	29 pcs
2		Ø8x30mm	Wood dowel	16 pcs
3		Ø15x11mm	Cam lock	25 pcs
4		Ø15x9mm	Small cam lock	4 pcs
5		Ø4x32mm	Fast screw	4 pcs
6			Drawer slider	1 set
7		Ø3.5x12mm	Screw	28 pcs
8			Handle	3 pcs
9		Ø4x22mm	Handle bolt	6 pcs
10			Door hinge	4 pcs
11		Ø3x12mm	Screw	2 pcs
12			Support pin	8 pcs
13			Screw	21 pcs
14		Ø4x44mm	Fast screw	4 pcs
15			Magnetic piece	2 pcs
16			Magnetic catch	2 pcs
17			Glue	1 pcs
18		Ø3x15mm	Screw	4 pcs
19		Ø6x30mm	Wood dowel	8 pcs
20		M4mm	Hexagon socket key	1 pcs

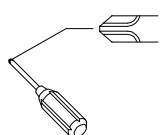

Philips head screwdriver required for assembly
(not included)

Step 1

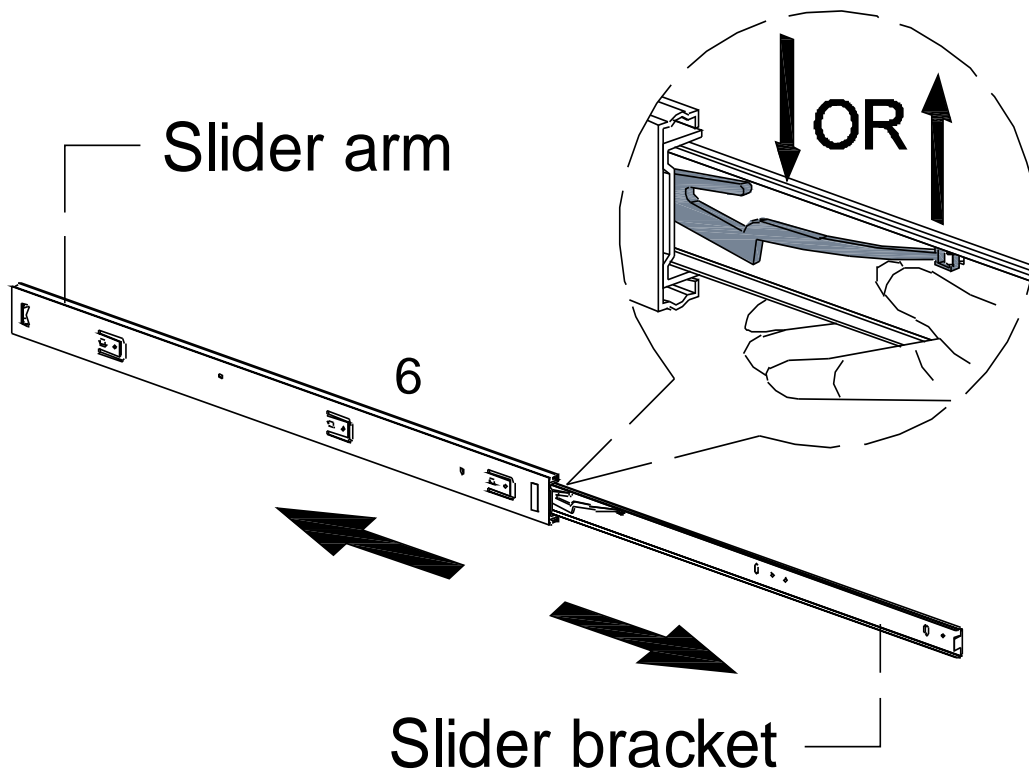

Step 2

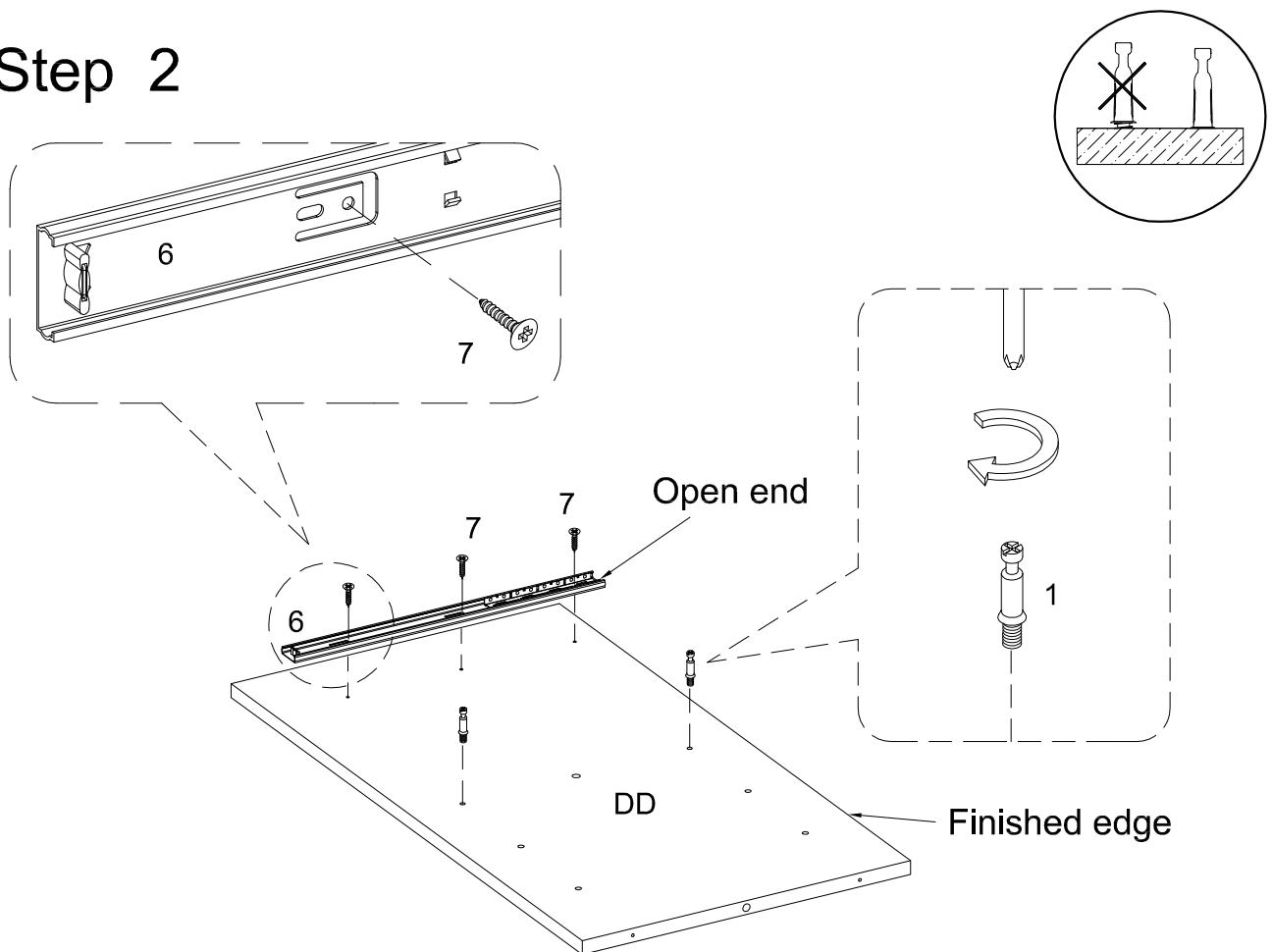

Step 3

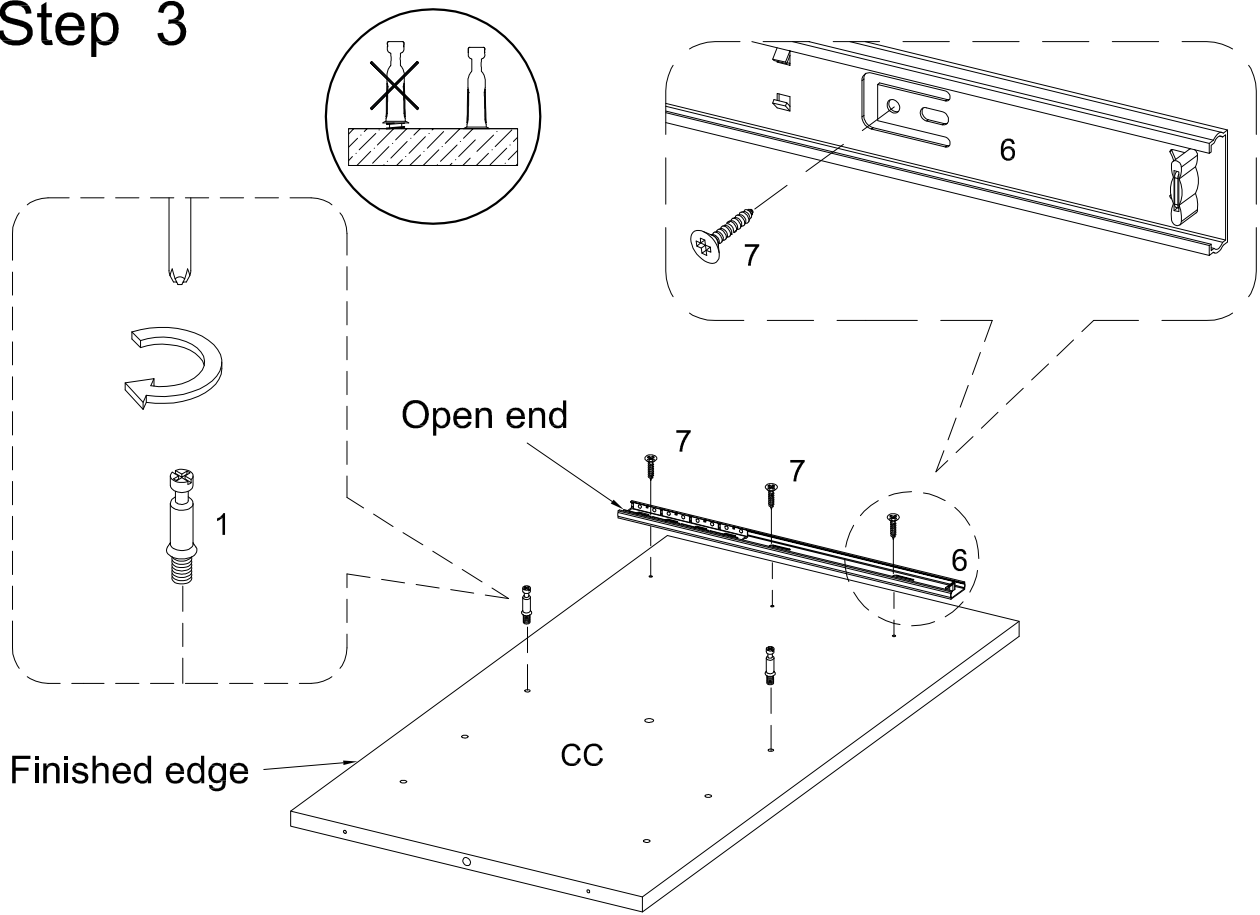

Step 4

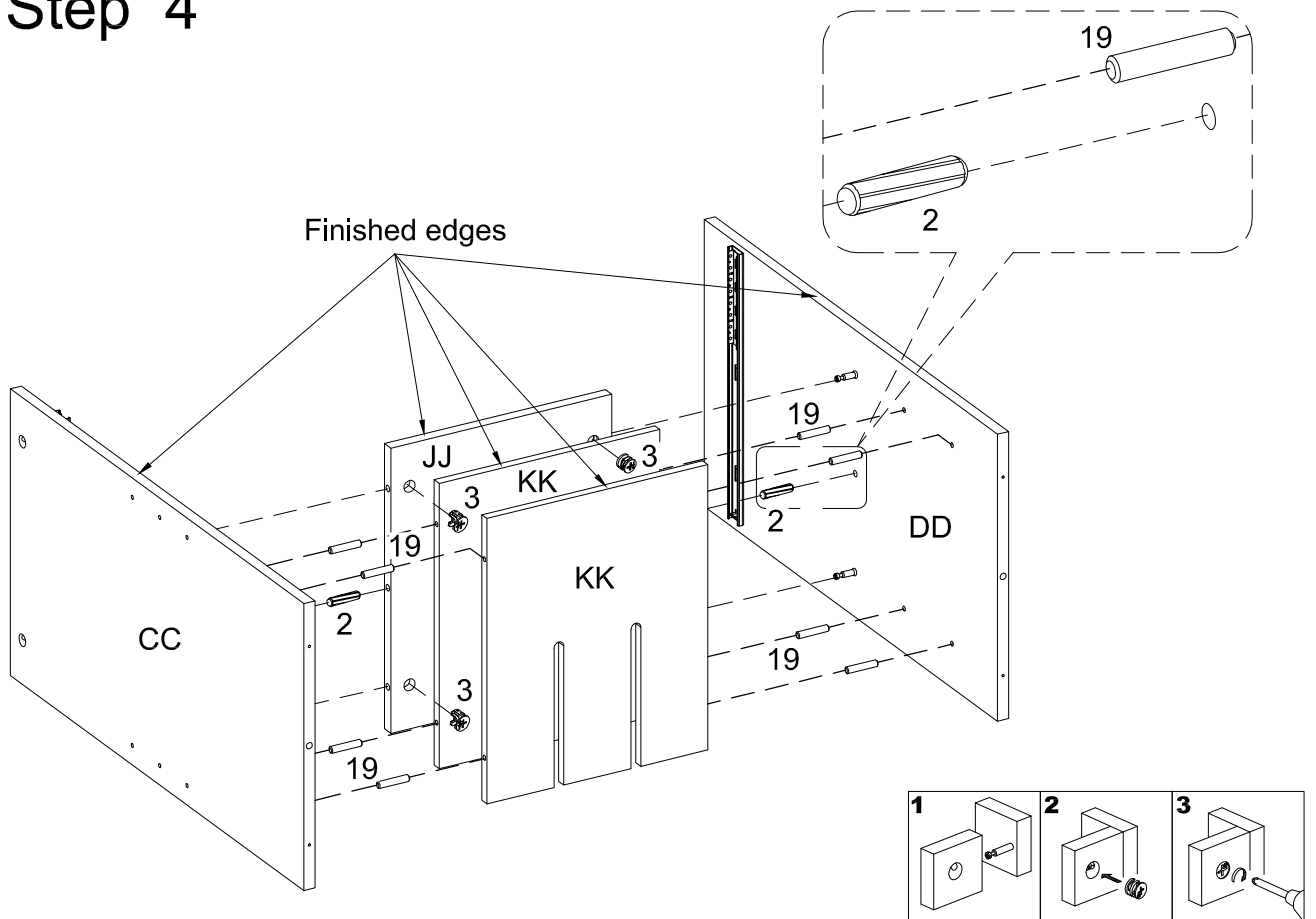

Step 5

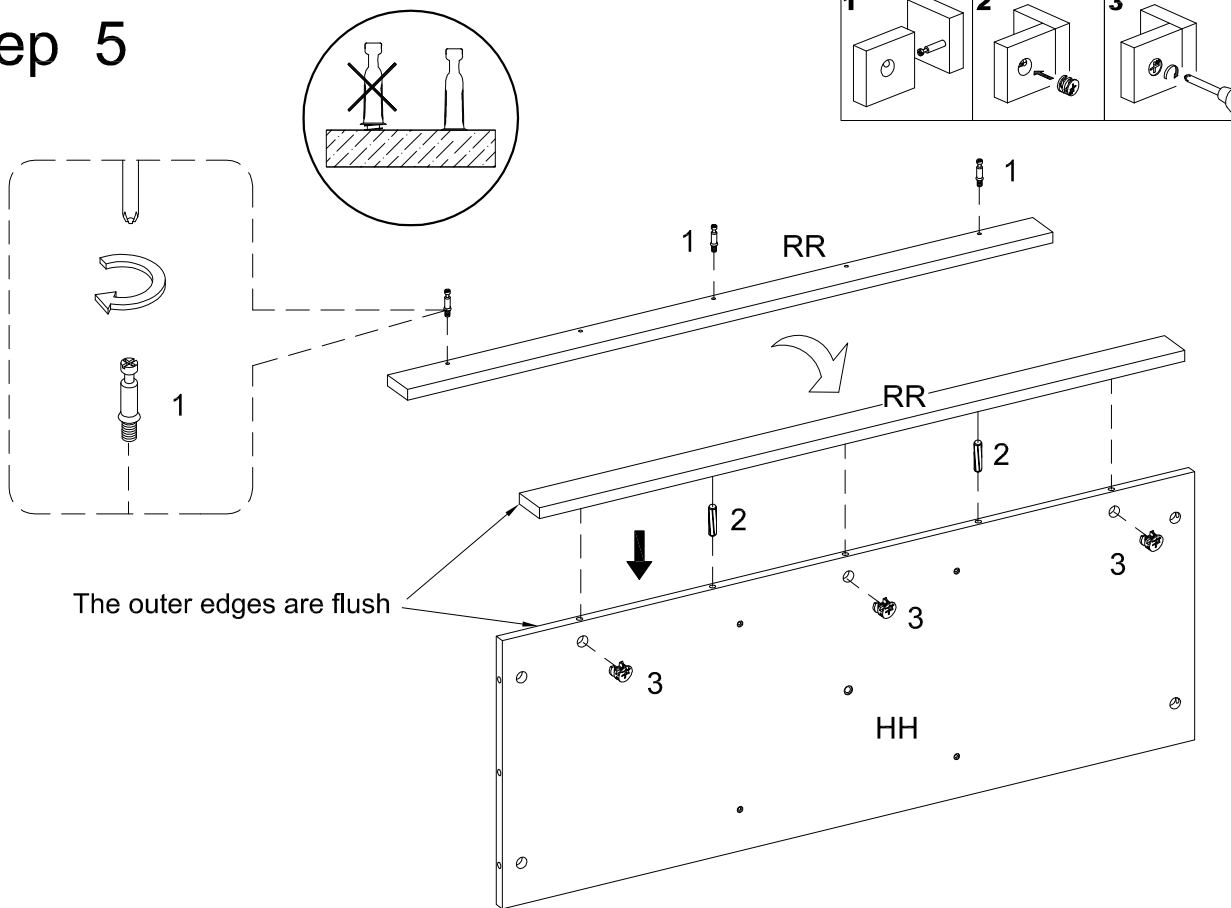

Step 6

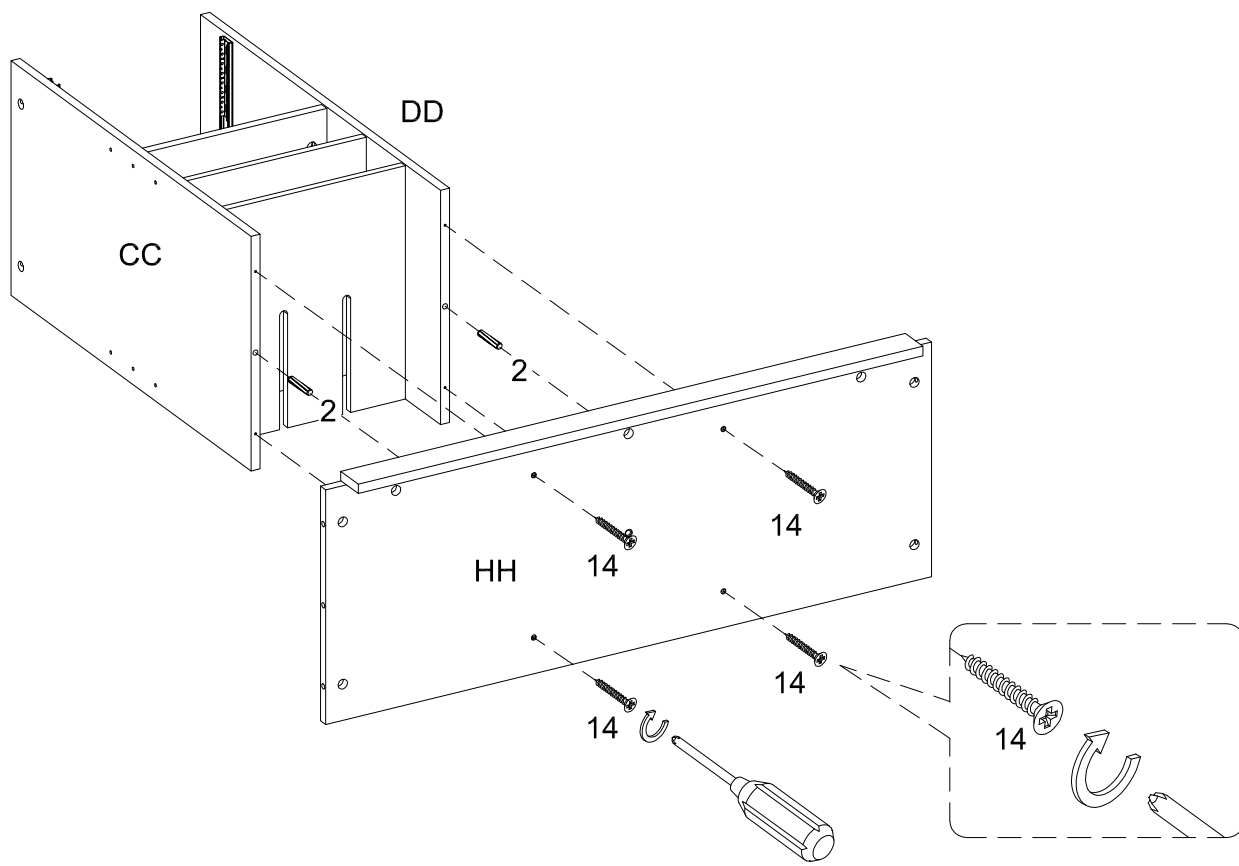

Step 7

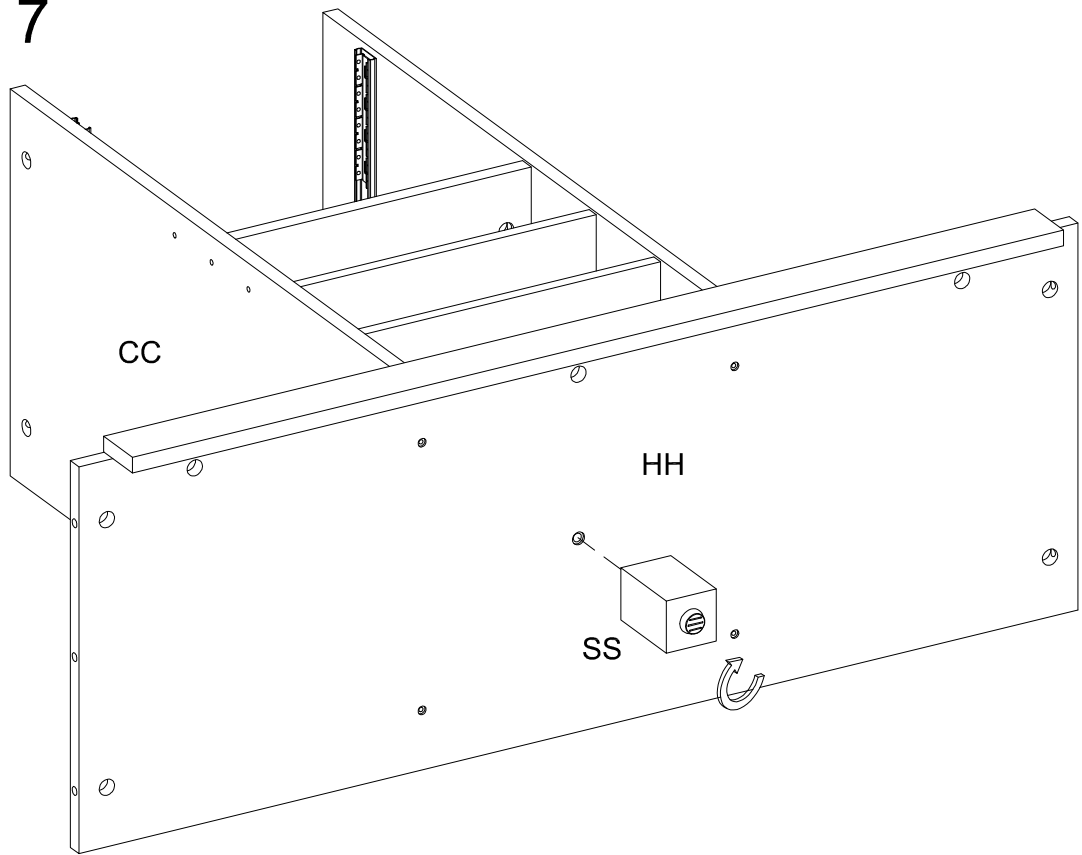

Step 8

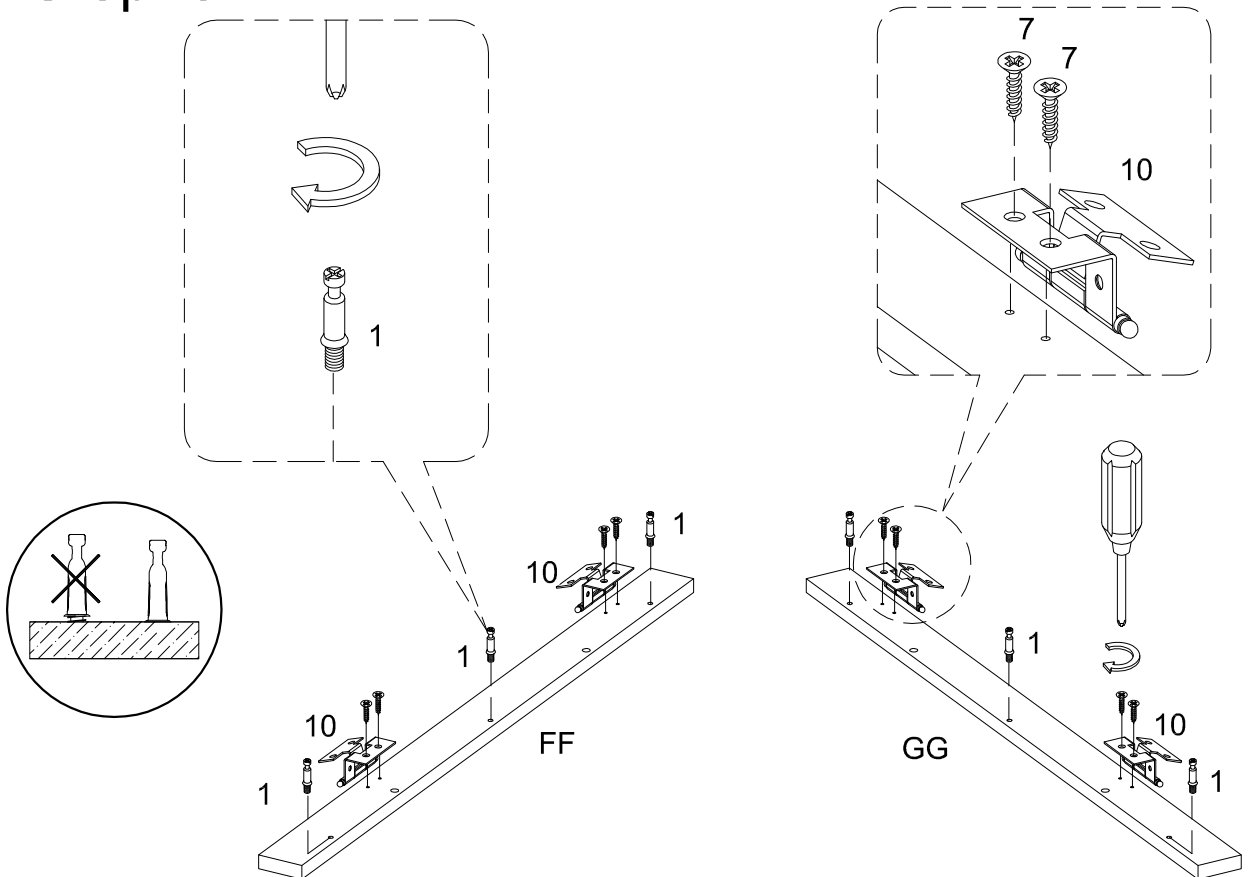

Step 9

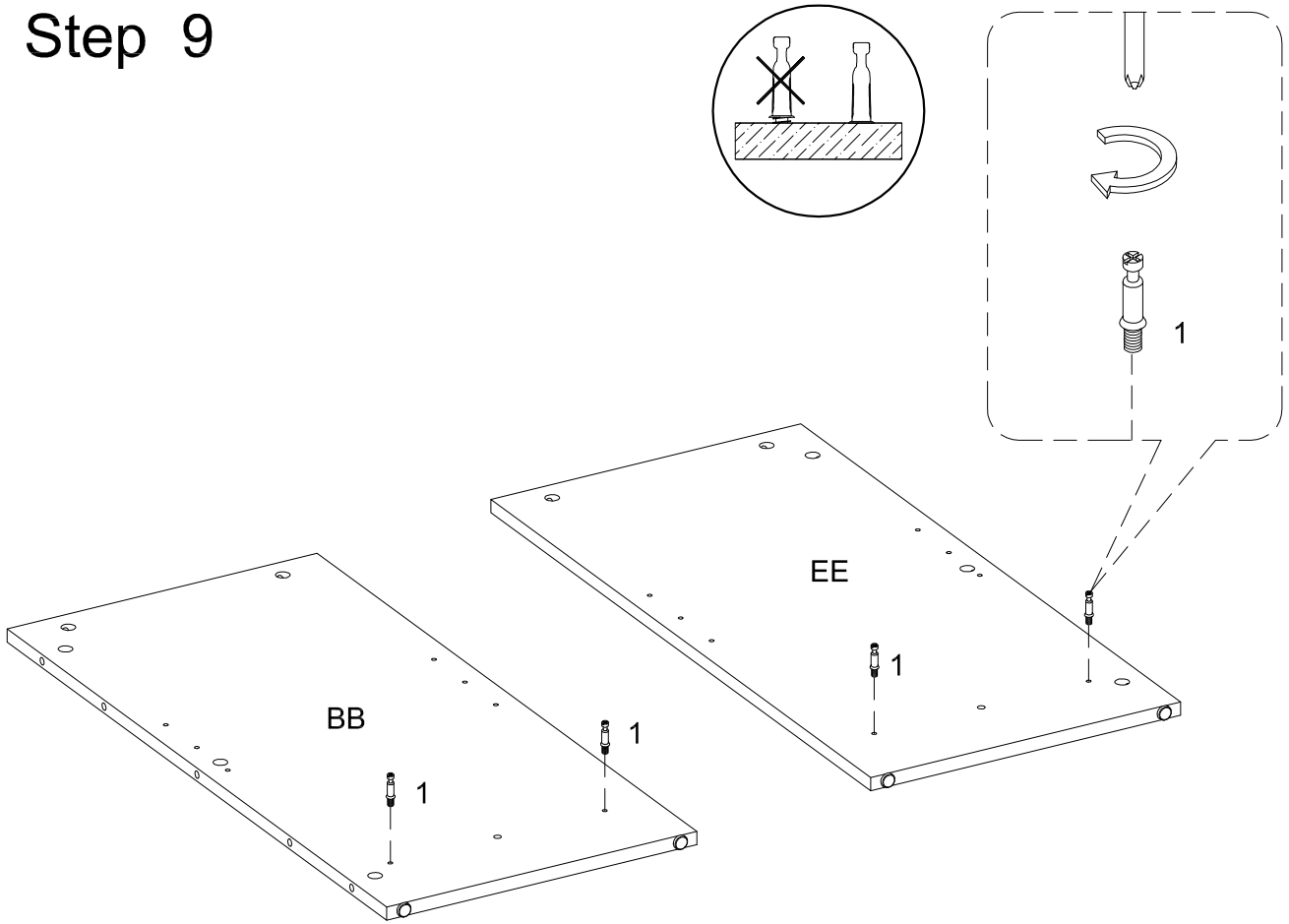

Step 10

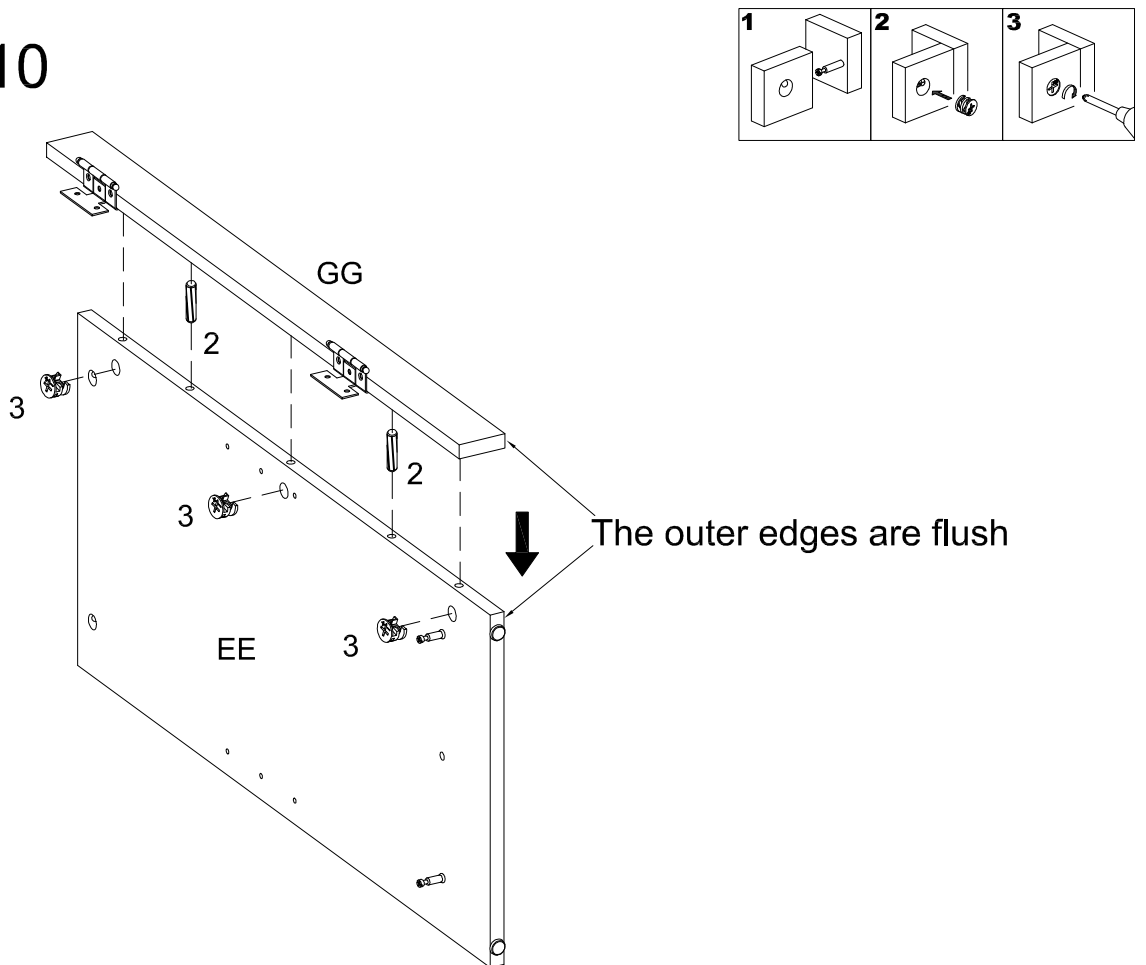

Step 11

The outer edges are flush

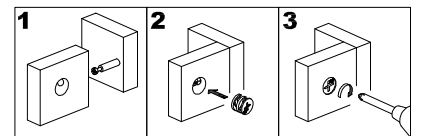
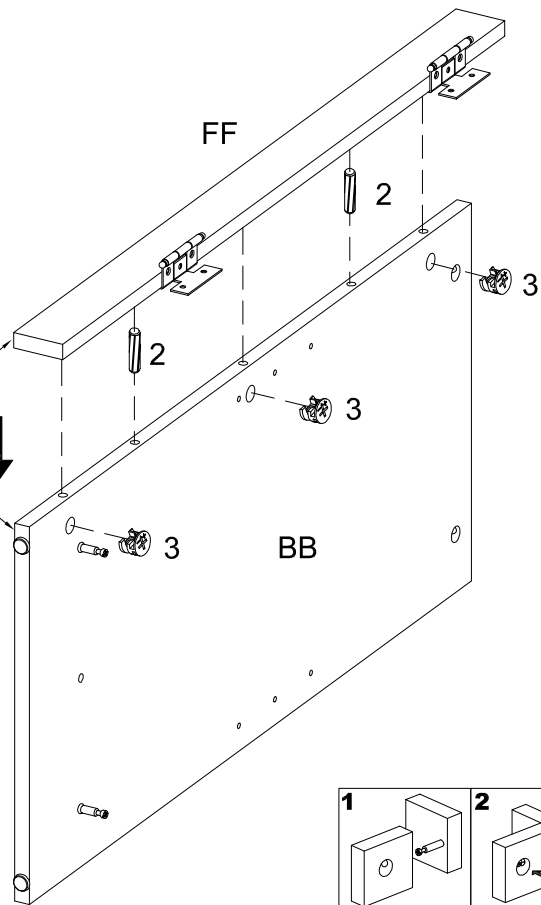

Step 12

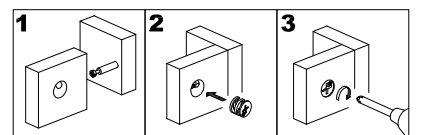
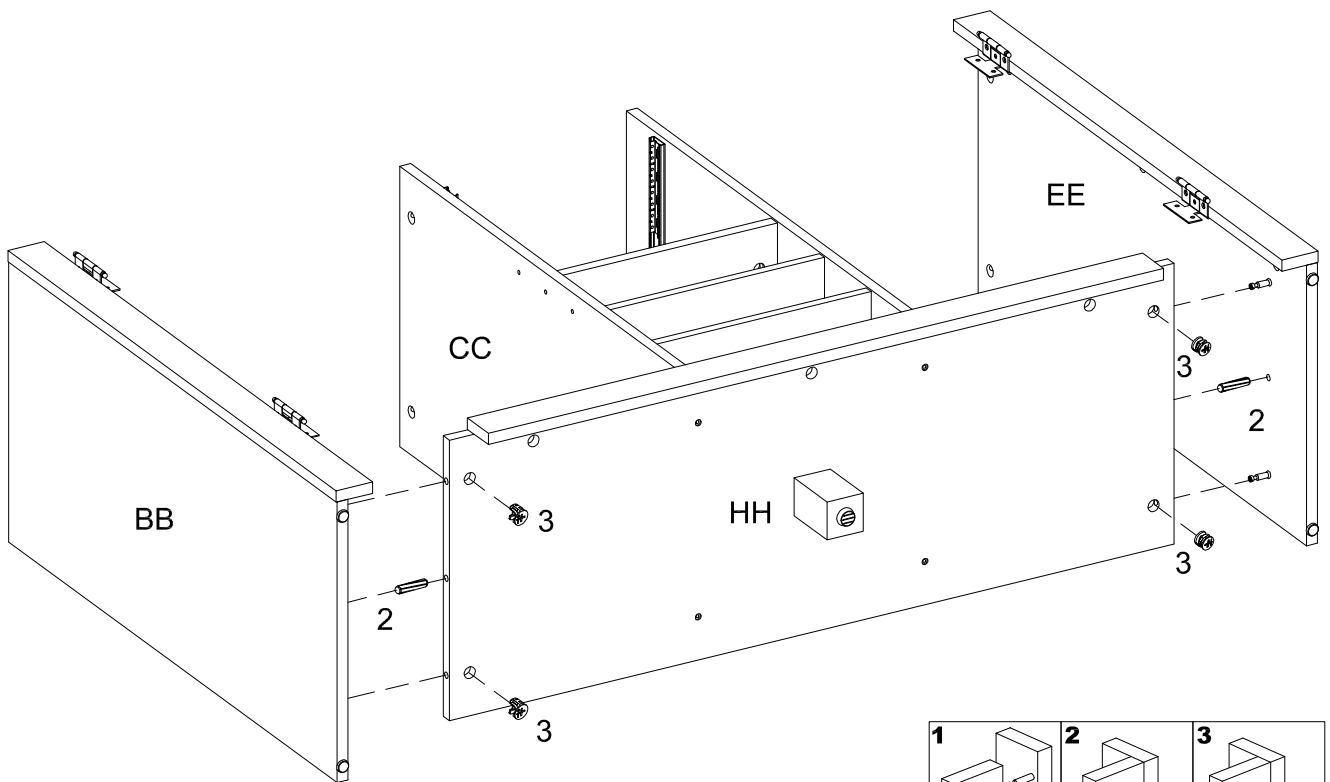

Step 13

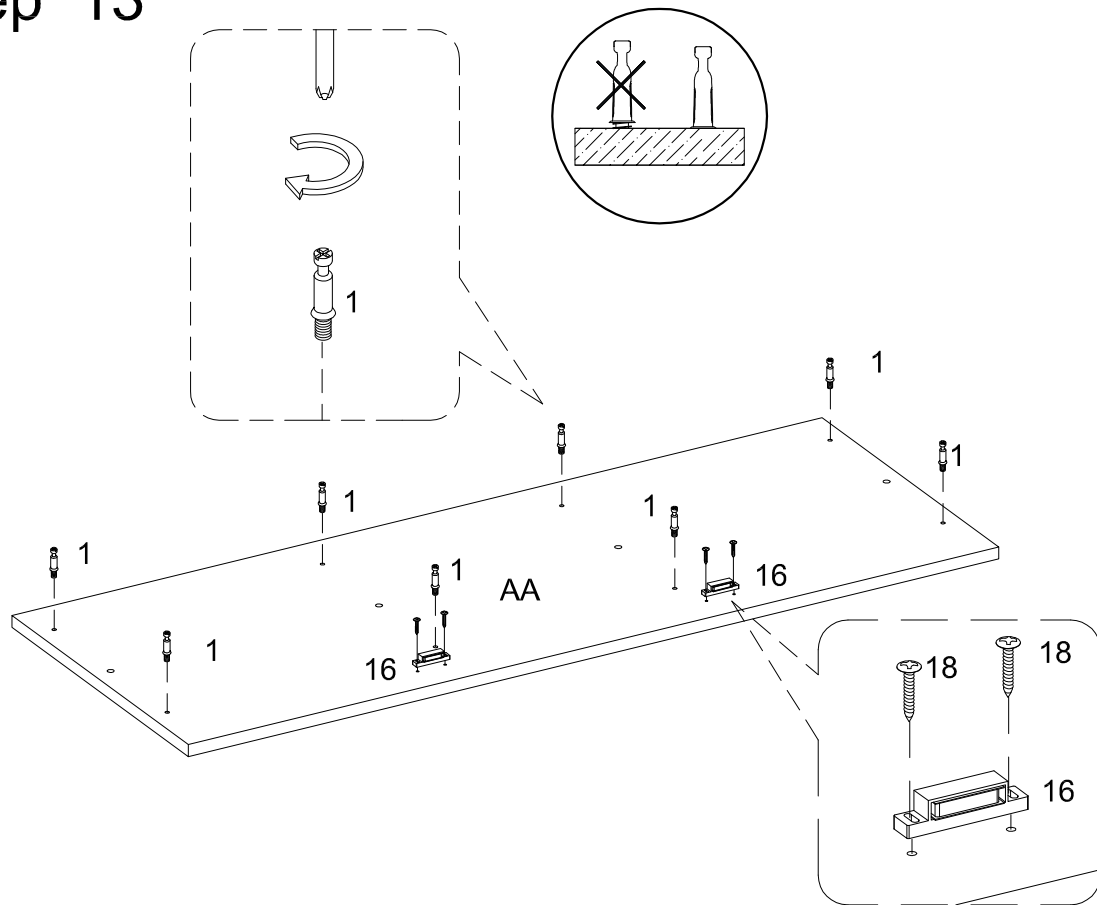

Step 14

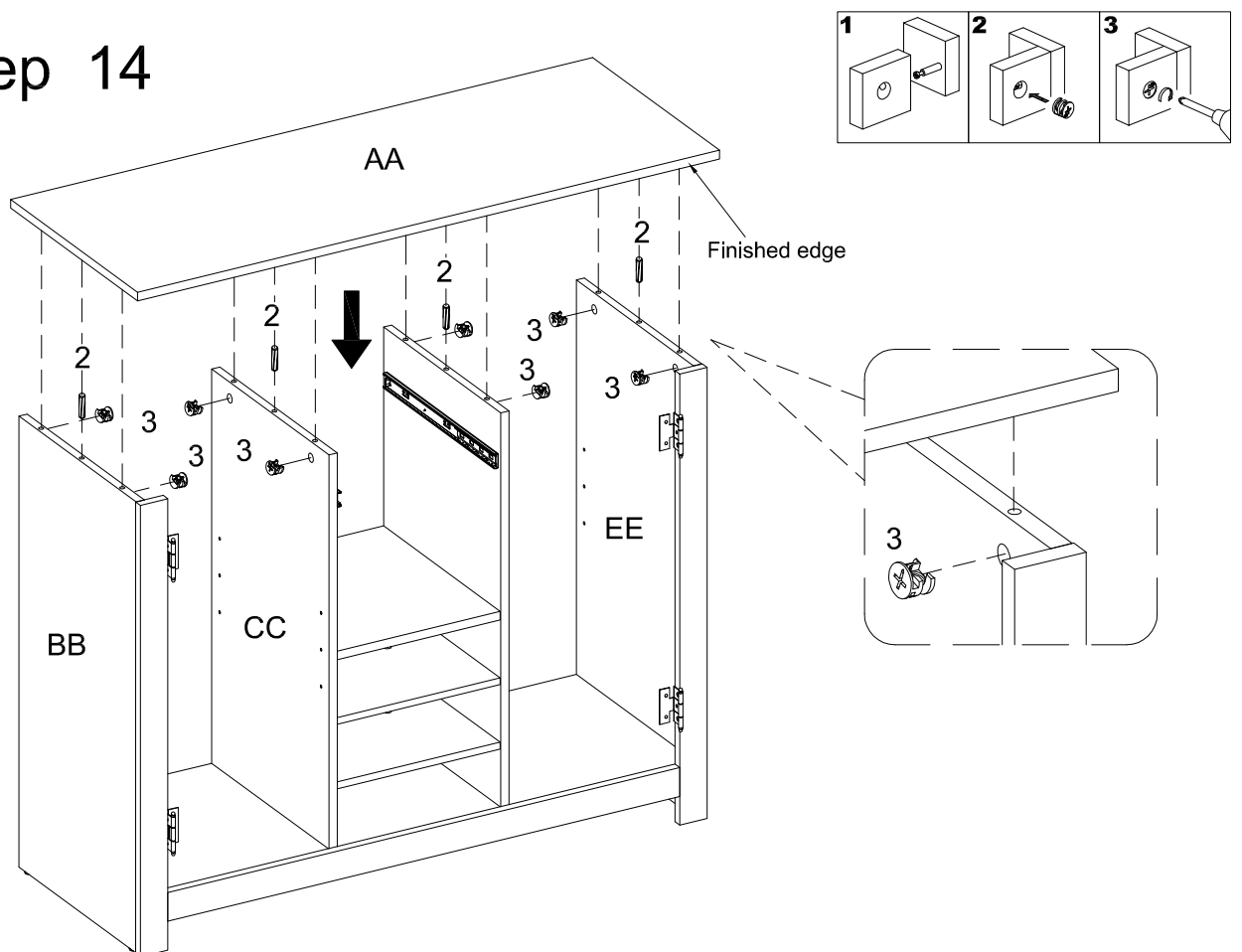

Step 15

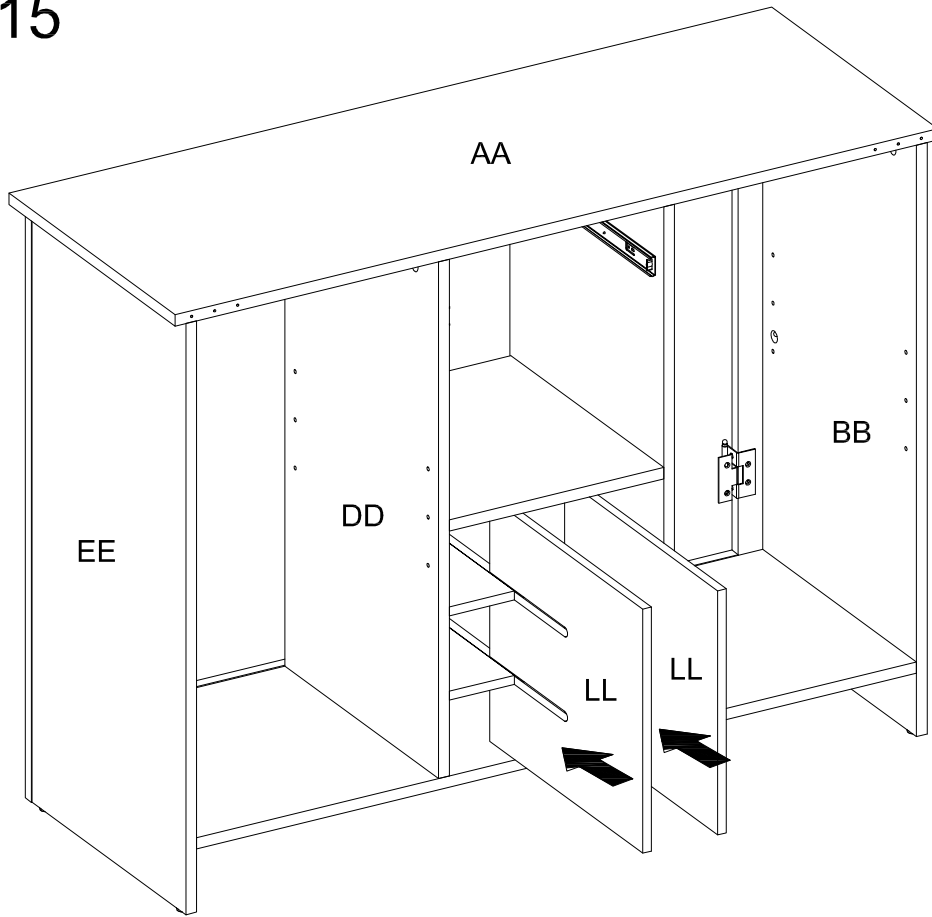

Step 16

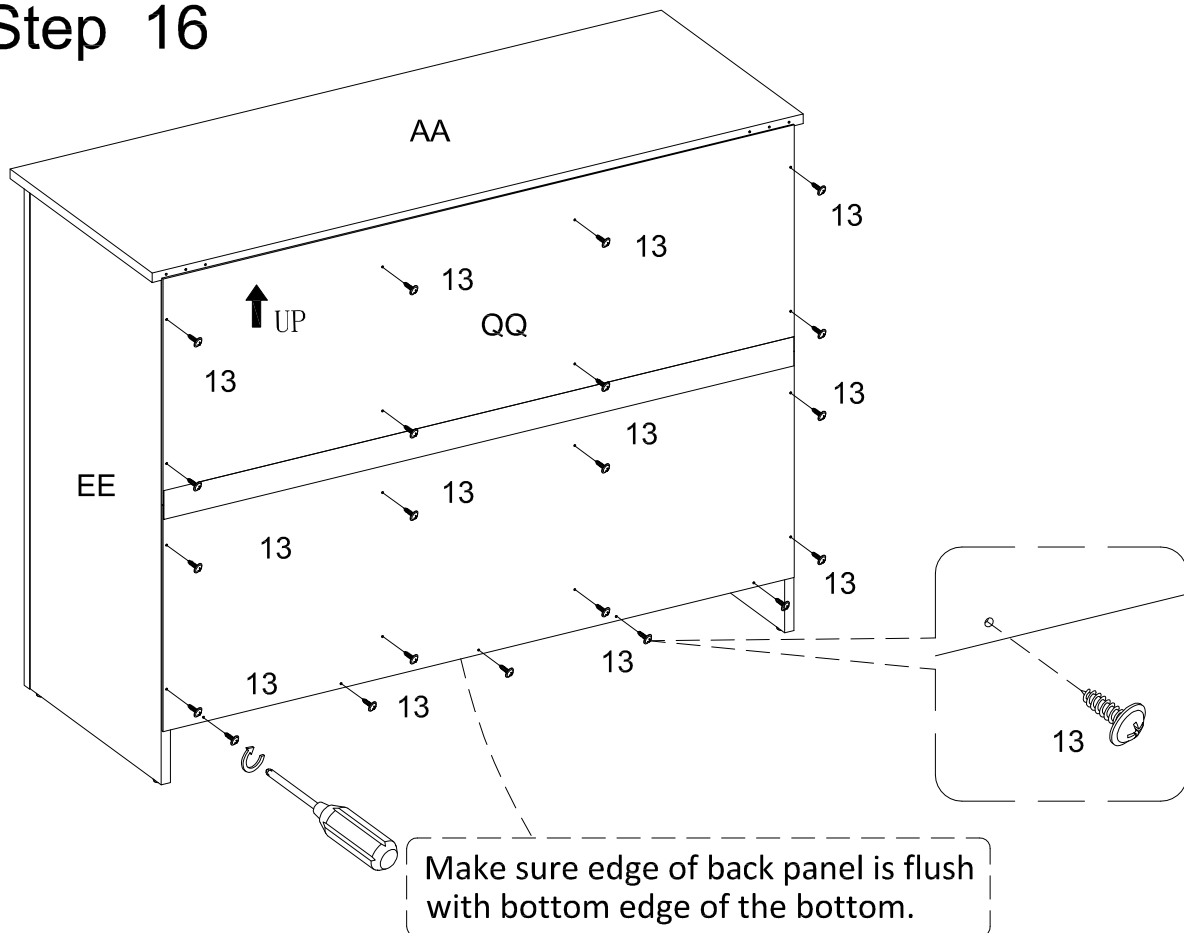

Step 17

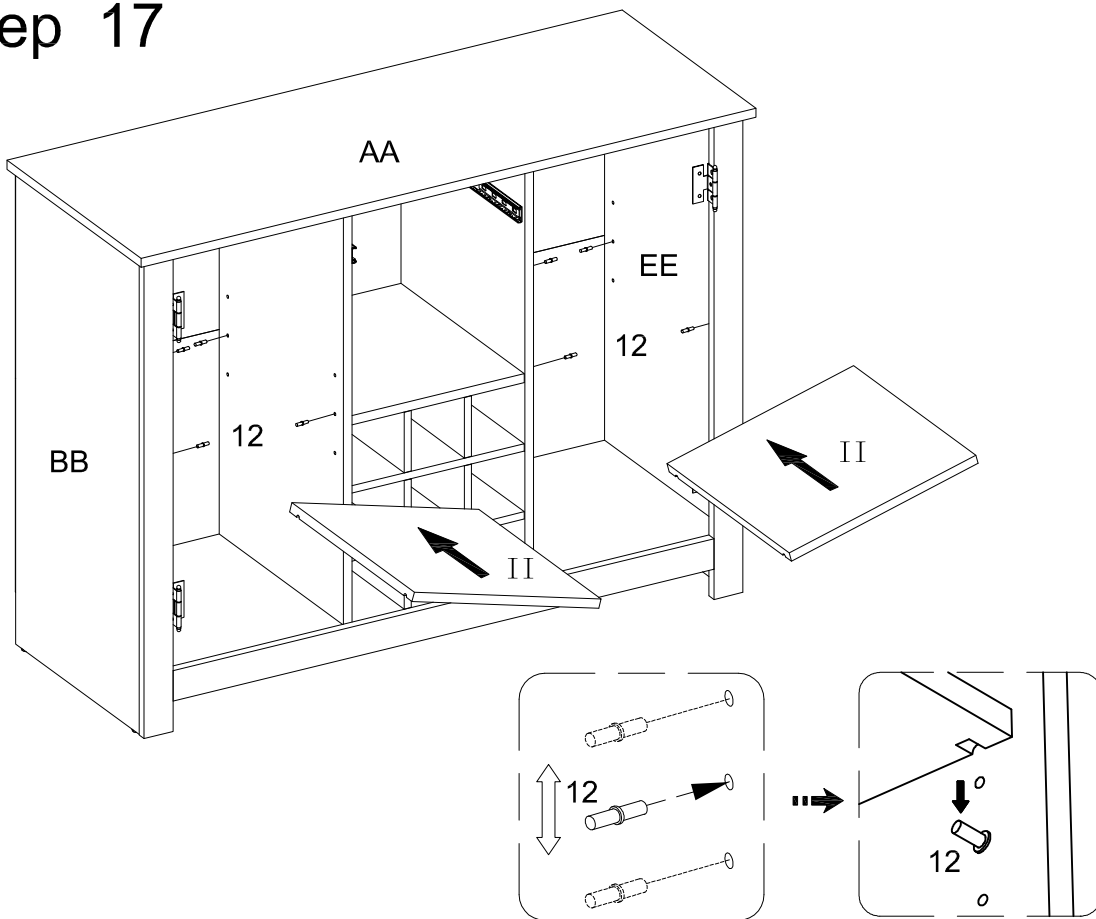

Step 18

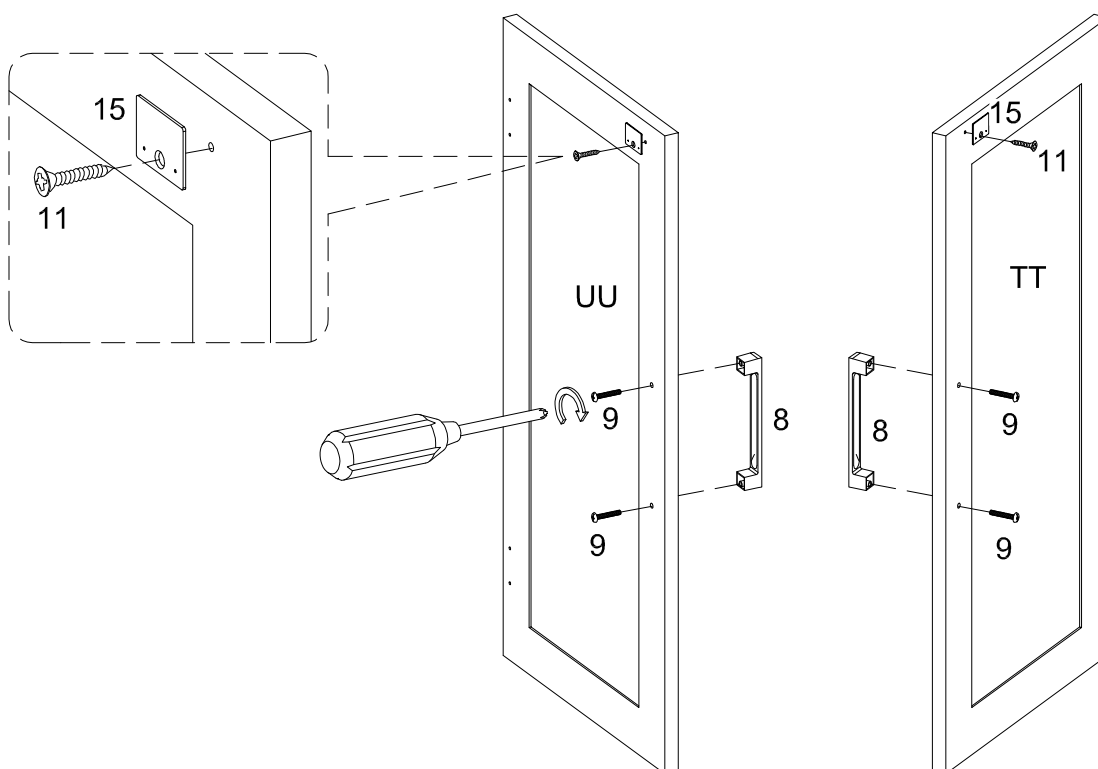

Step 19

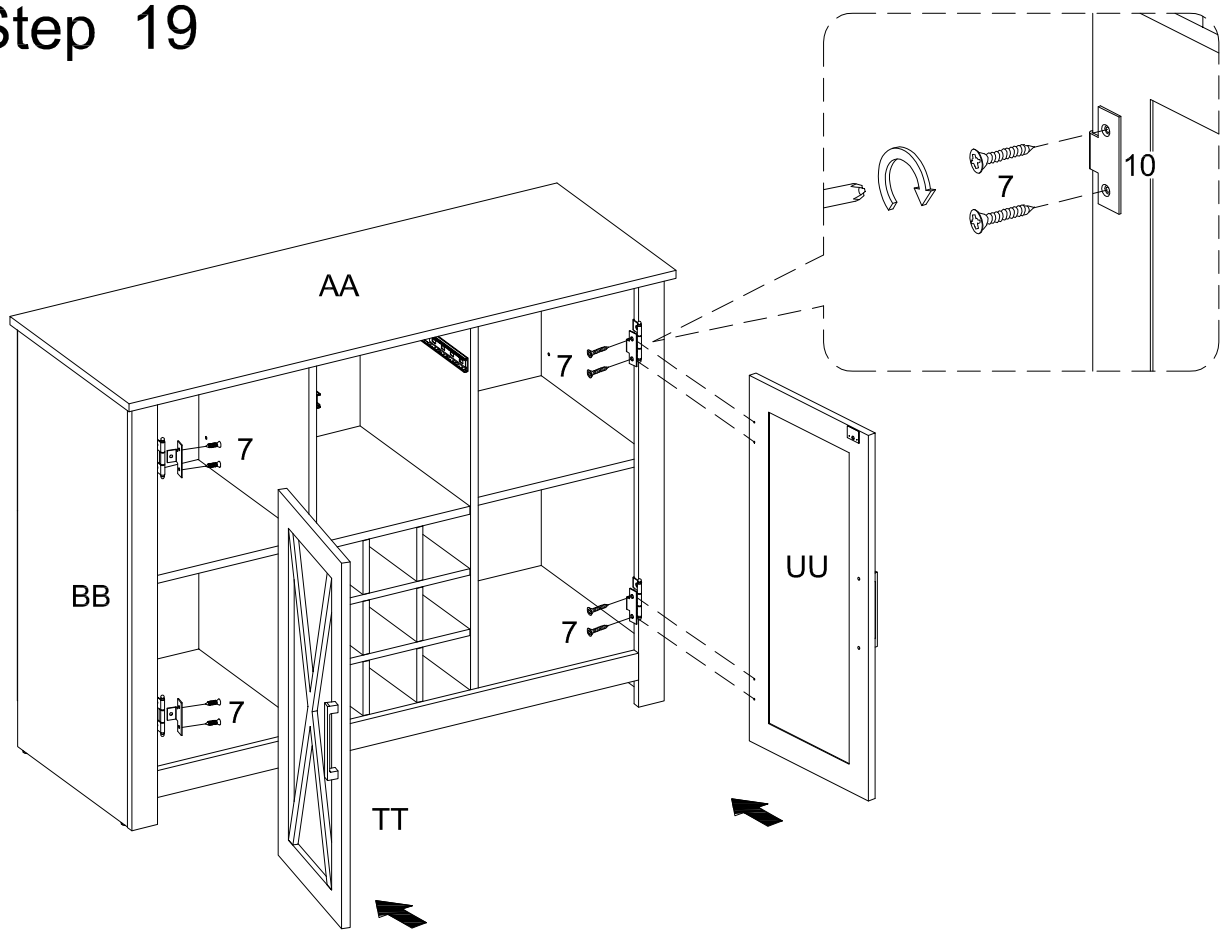

Step 20

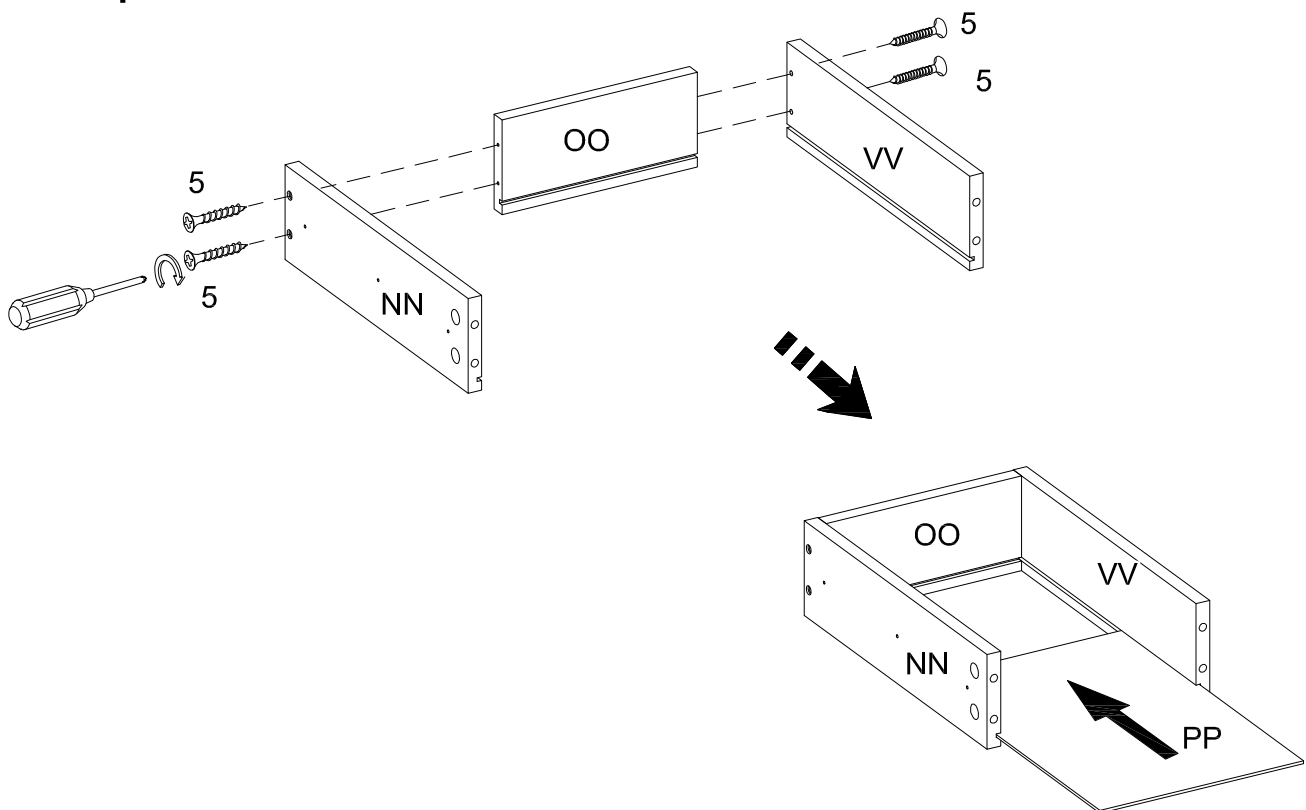

PRODUCT RECOMMENDATION

Combine with matching hutch for additional work center storage.

