

# ASSEMBLY INSTRUCTION

## PATIO FURNITURE SETS

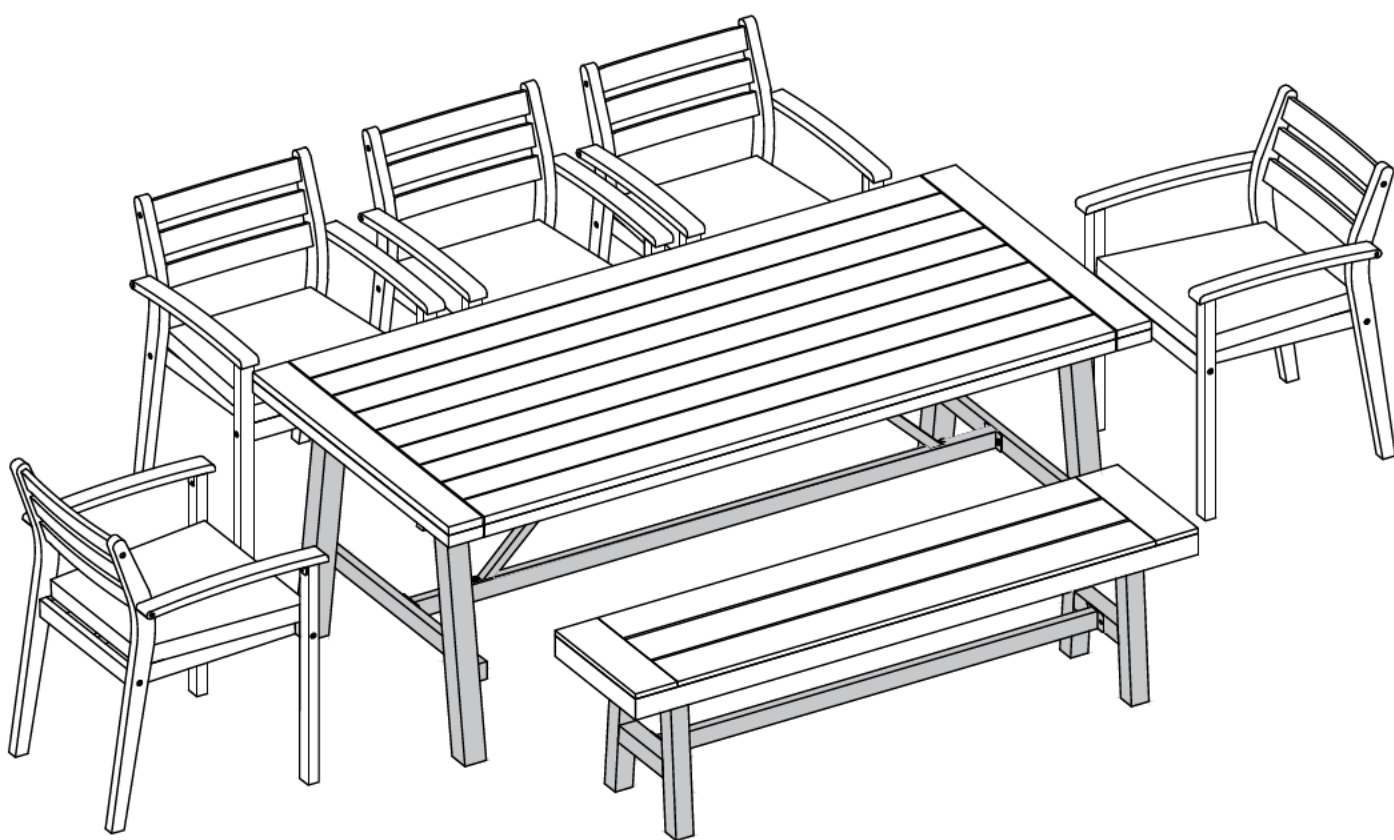

X1

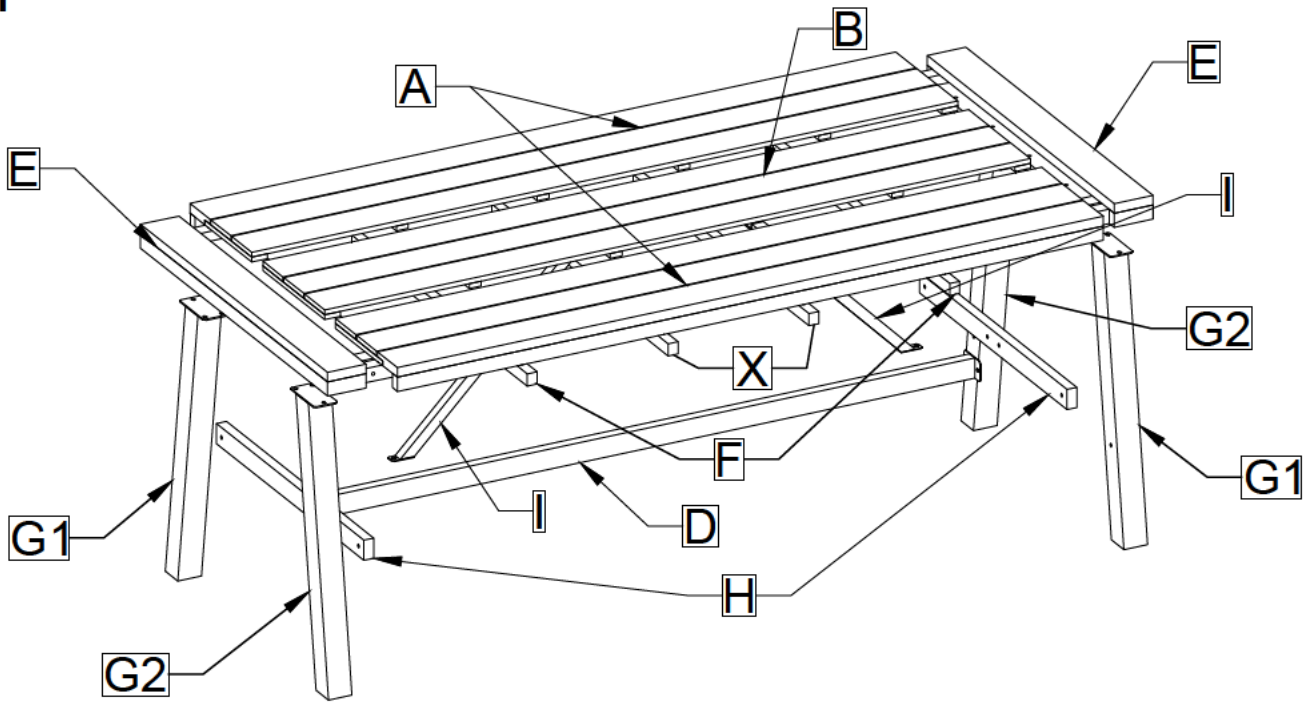

X1

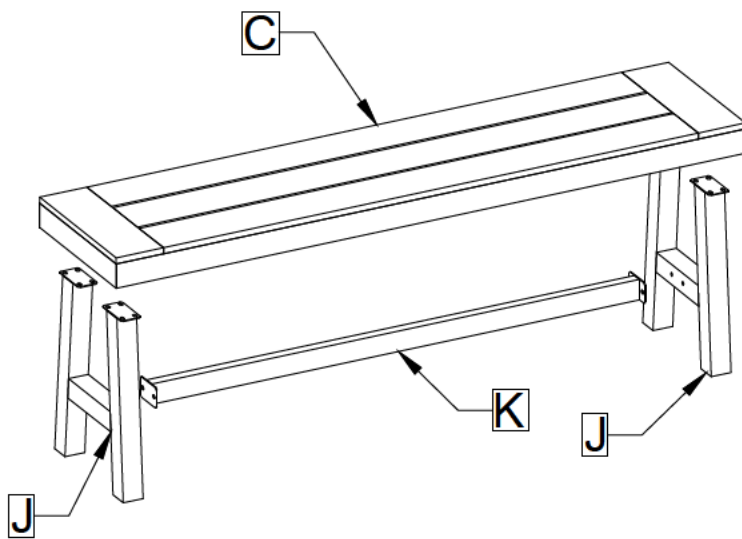

X5

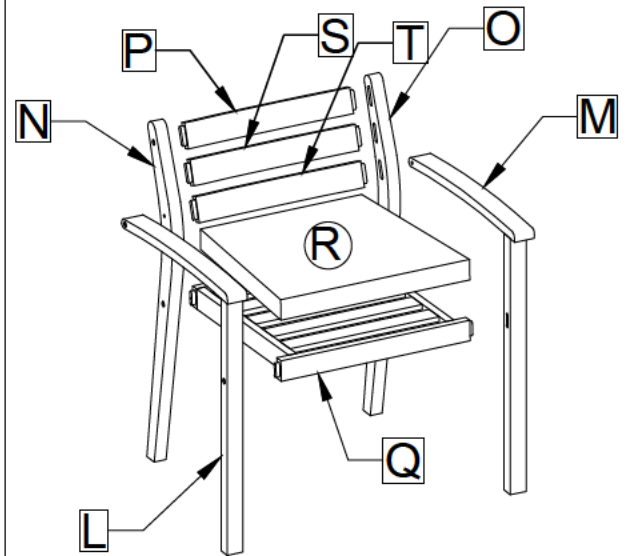

Note:

1. 50% Tighten before fixing all screws, Allen wrench is recommended instead of an electric drill.
2. Place the item on a flat ground to adjust and make sure it remains stable.
3. Tighten up all screw with tools gradually.
4. If screw are not aligned with holes during assembly, please loosen all the other screws to 50% and continue the assembly process.
5. If the item is not stable, please loosen all screws, adjust it on a flat ground and tighten up all screws again.
6. Note: If one or some screws are fully tighten during assembly, chances are the others will not be aligned with holes. In addition, all the holes are designed to be relatively larger to provide more space for the adjustment of the screws.

CARTON CONTENT:

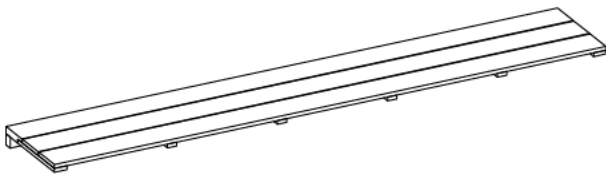

Ⓐx2

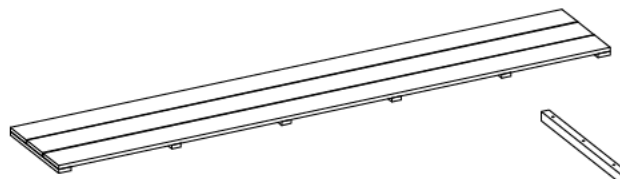

Ⓑx1

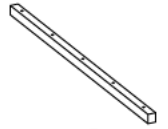

ⓧx2

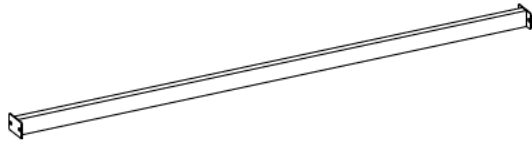

Ⓓx1

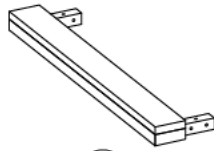

Ⓔx2

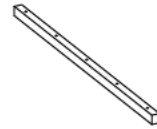

Ⓕx2



Ⓖ1x2



Ⓖ2x2

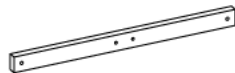

Ⓗx2



Ⓘx2



Ⓙx5



Ⓚx1



Ⓝx1



Ⓞx1



Hardware

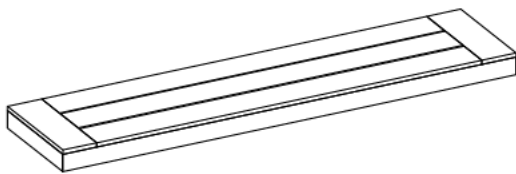

Ⓒx1



Ⓝx4



Ⓞx4



Ⓟx5

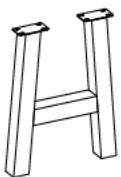

Ⓙx2

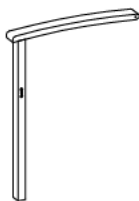

Ⓛx5



Ⓜx5

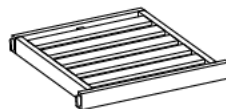

Ⓠx5

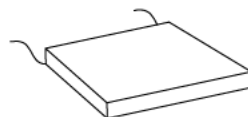









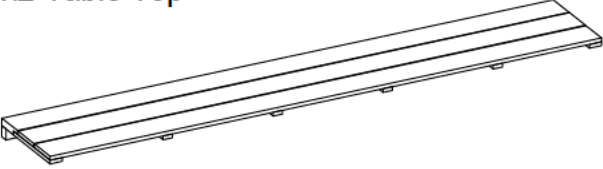
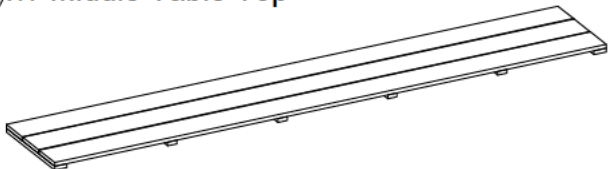
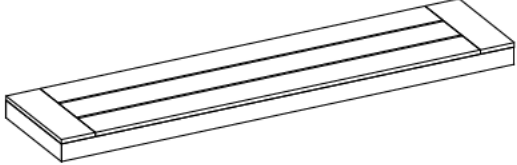
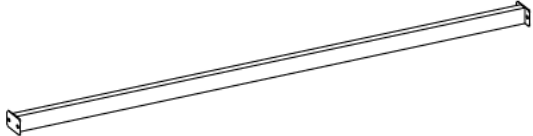
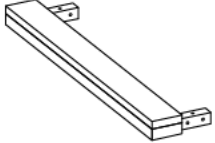
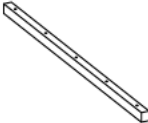



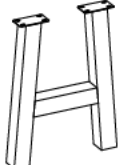

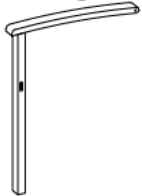
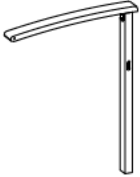

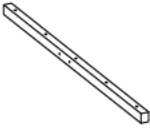

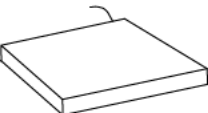







Ⓡx5



Ⓢx5

# Part List & Hardware List:

<b>A</b> x2-Table Top 		<b>B</b> x1-Middle Table Top 			
<b>C</b> x1-Seat Bench 		<b>D</b> x1-Bottom Table 			
<b>E</b> x2-Side Table Top 	<b>F</b> x2-Support Table Top 	<b>G1</b> x2-Right Table Leg 	<b>G2</b> x2-Left Table Leg 	<b>H</b> x2-Front Table Leg 	
<b>I</b> x2- Support Table Leg 	<b>J</b> x2-Bench Leg 	<b>K</b> x1-Support Bench Leg 	<b>L</b> x5-Arm Right 		
<b>M</b> x5-Arm Left 	<b>N</b> x5-Right Back Leg 	<b>O</b> x5-Left Back Leg 	<b>X</b> x2-Support Middle Table Top 		
<b>Q</b> x5-Seat 	<b>R</b> x5-Seat Cushion 	<b>S</b> x5-Back Middle 	<b>P</b> x5-Back Top 	<b>T</b> x5-Back Bottom 	
<b>1</b> x38-Bolt M6 x 20MM extra (3) 	<b>2</b> x4-Bolt M6 x 45MM extra (1) 	<b>3</b> x46 Flat Washer extra (4) 	<b>4</b> x4-Scew Bolt M6 x 20MM extra (1) 	<b>5</b> x8- Scew Bolt M6 x 30MM extra (1) 	<b>6</b> x12-Scew Bolt M6 x 45MM extra (2) 
<b>7</b> x10-Scew Bolt M6 x 90MM extra (1) 	<b>8</b> x2-Allen Key 	<b>9</b> x10-Scew Bolt M6 x 60MM extra (1) 	<b>10</b> x10-Scew Bolt M7 x 60MM extra (1) 	<b>11</b> x10-Scew Bolt M7 x 90MM extra (1) 	<b>12</b> x24-Scew Bolt M6 x 50MM extra(3) 

- A** x2
- B** x1
- E** x2
- 5** x8

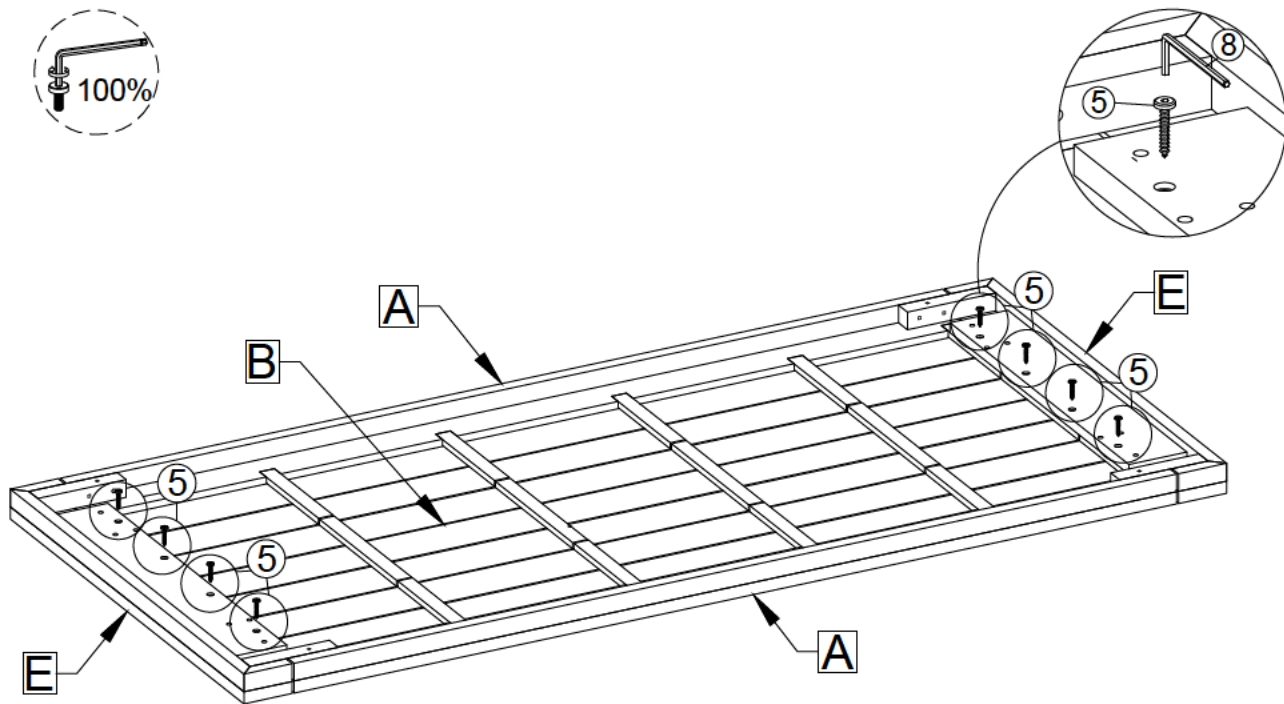

Step 1: Connect Table Top (A) & Middle Table Top (B), Side Table Top (E), tighten Screw Bolt (5) with Allen Key (8).

- 6** x12

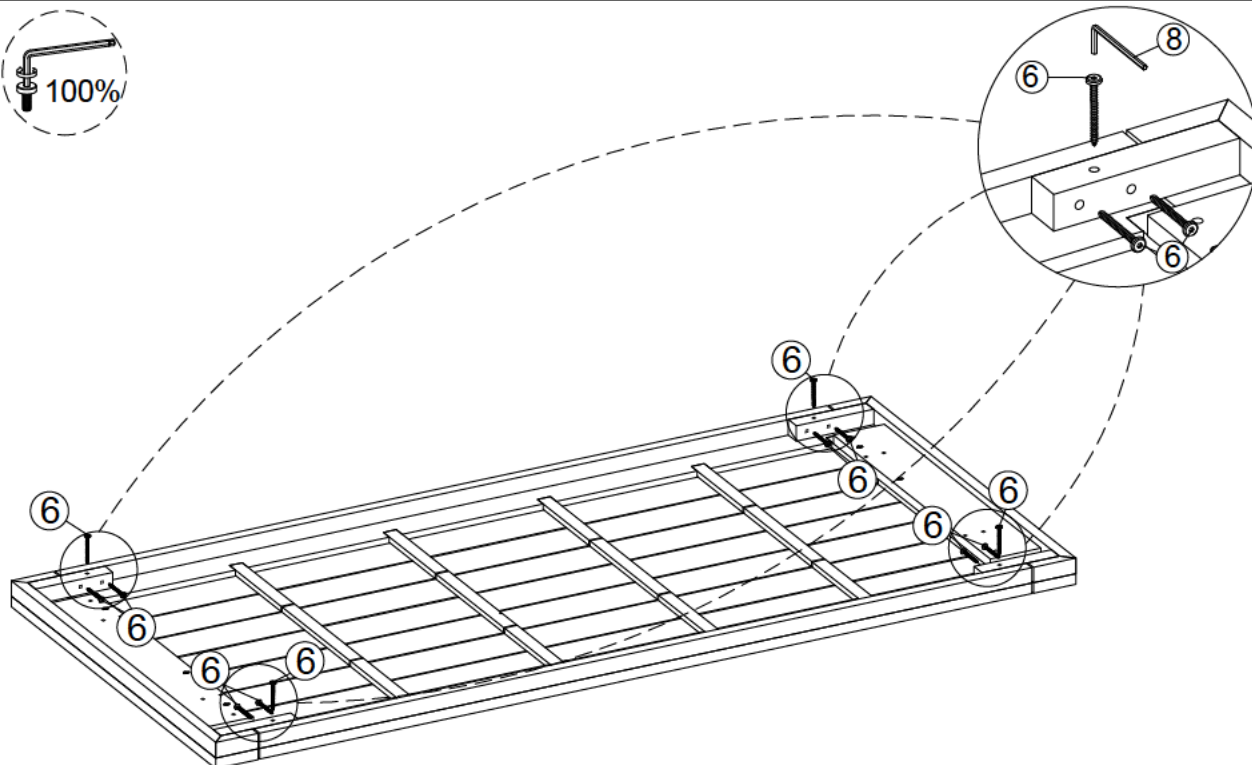

Step 2: Connect The Part from Step 1, tighten Screw Bolt (6) with Allen Key (8).

- F**x2
- X**x2
- 12**x24

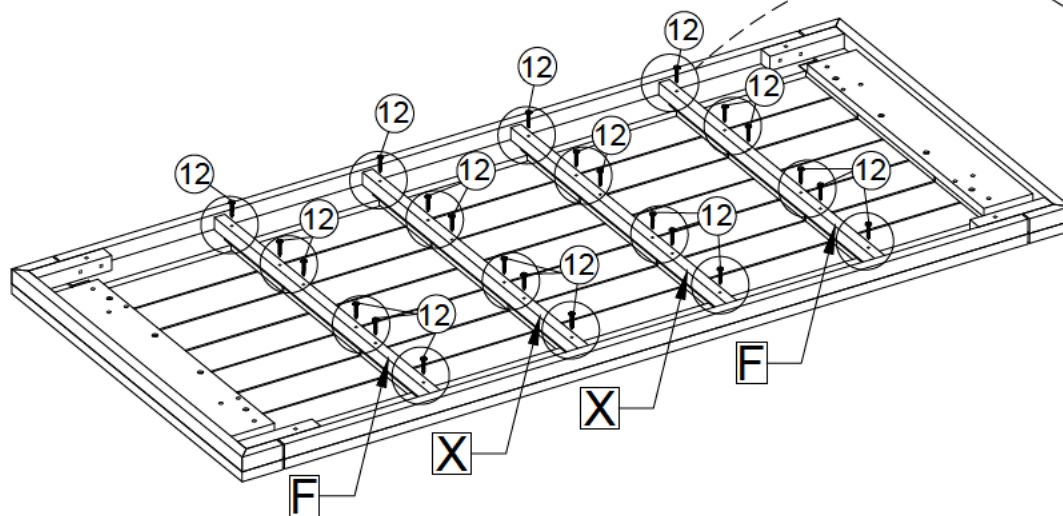
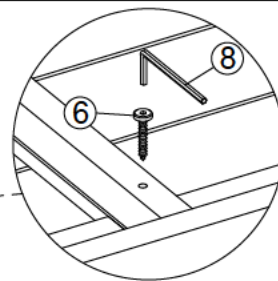

**Step 3: Connect The Part from Step 2 & Support Table Top (F), Support Middle Table Top (X), tighten Screw Bolt (12) with Allen Key (8).**

- G1**x2
- G2**x2
- 1**x12
- 3**x12

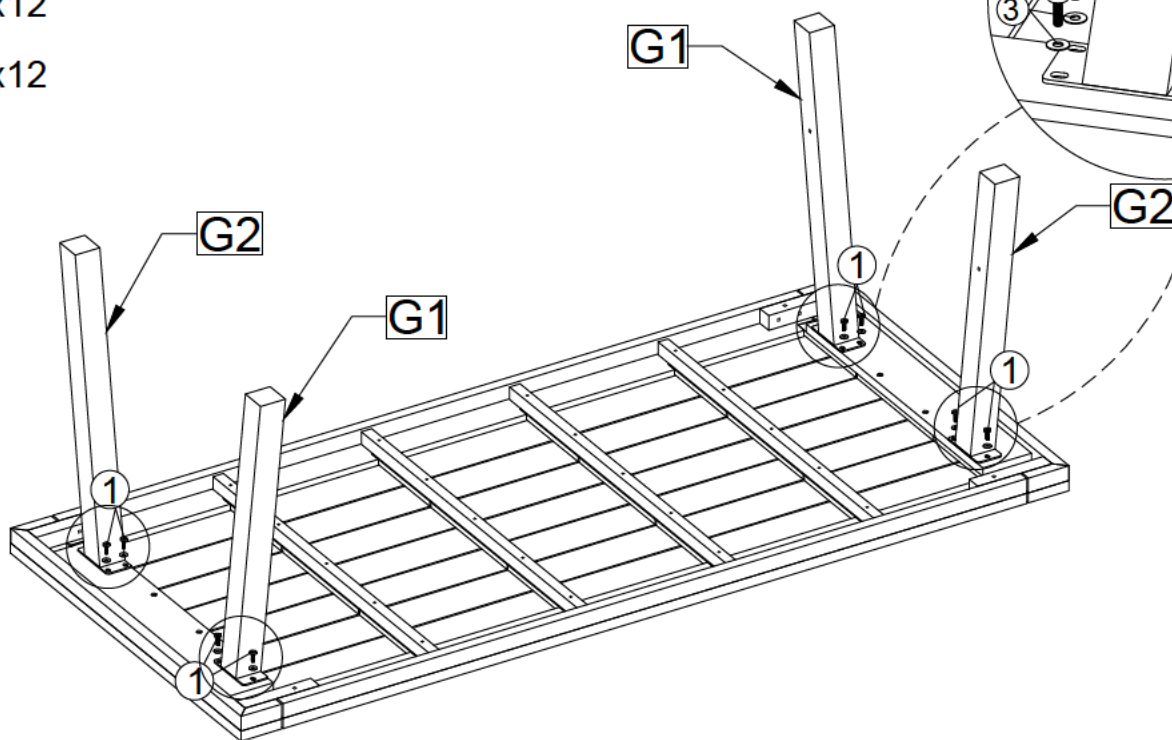
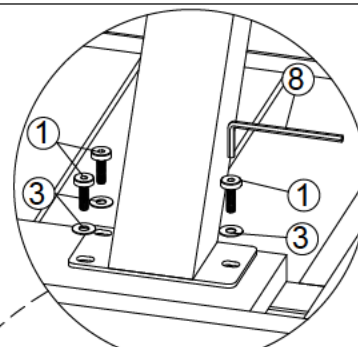

**Step 4: Connect The Part from 3 & Right Table Leg (G1), Left Table Leg (G2) tighten Bolt (1), Flat Washer (3) with Allen Key (8).**

- H**x2
- 2**x4
- 3**x4

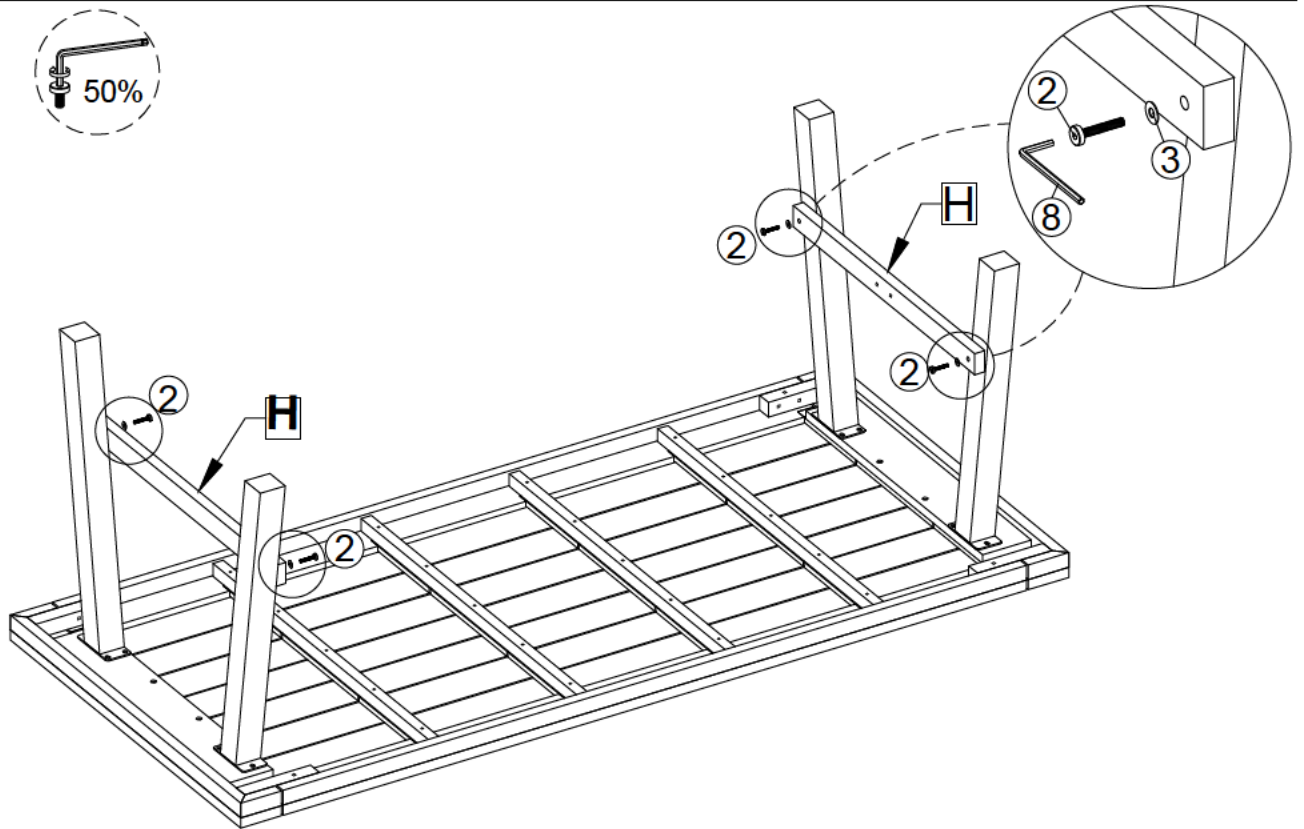

Step 5: Connect The Part from Step 4 & Front Table Leg (H), tighten Bolt (2), Flat Washer (3) with Allen Key (8).

- D**x1
- 1**x4
- 3**x4

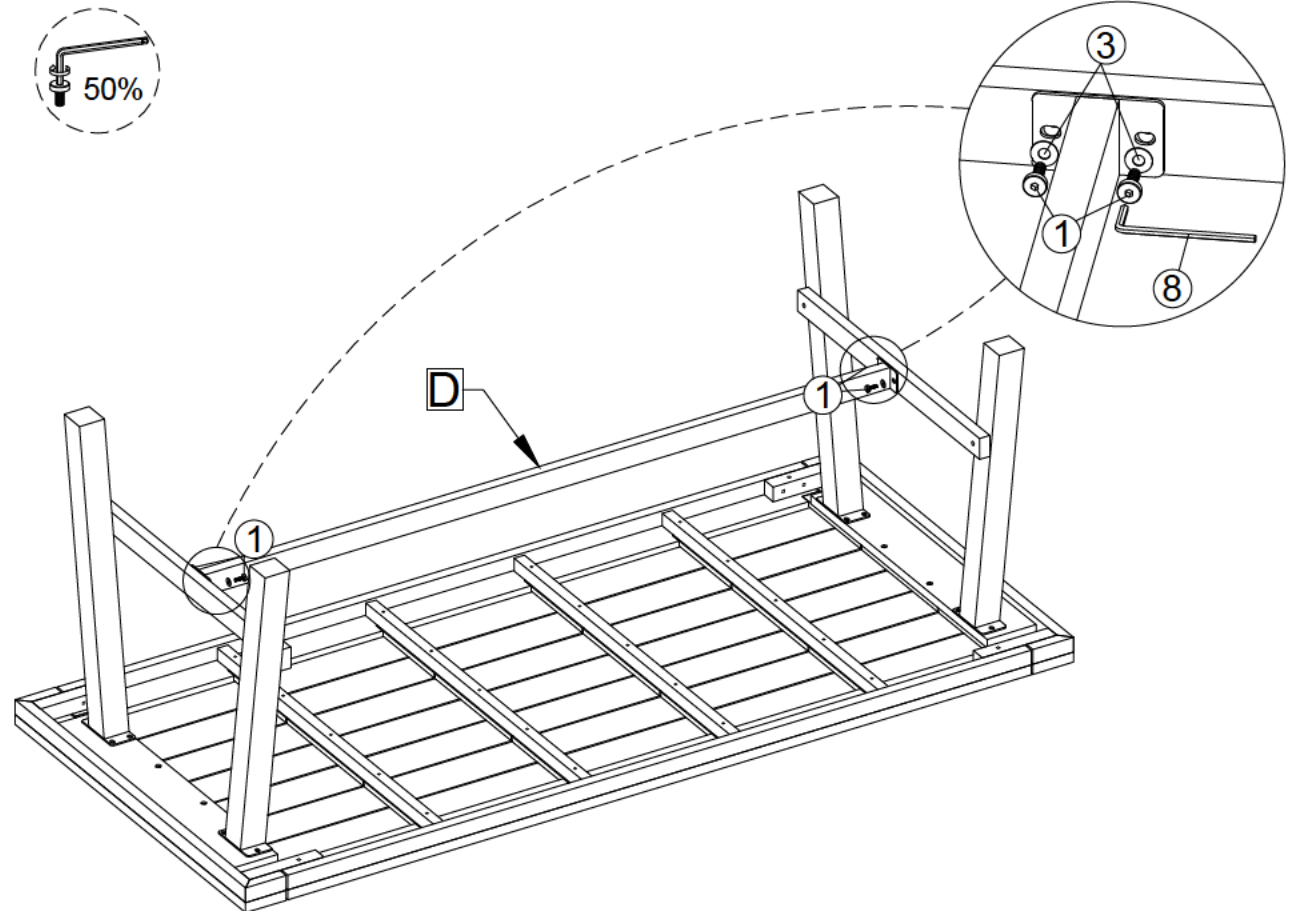

Step 6: Connect The Part from Step 5 & Bottom Table (D), tighten Bolt (1), Flat Washer (3) with Allen Key (8).

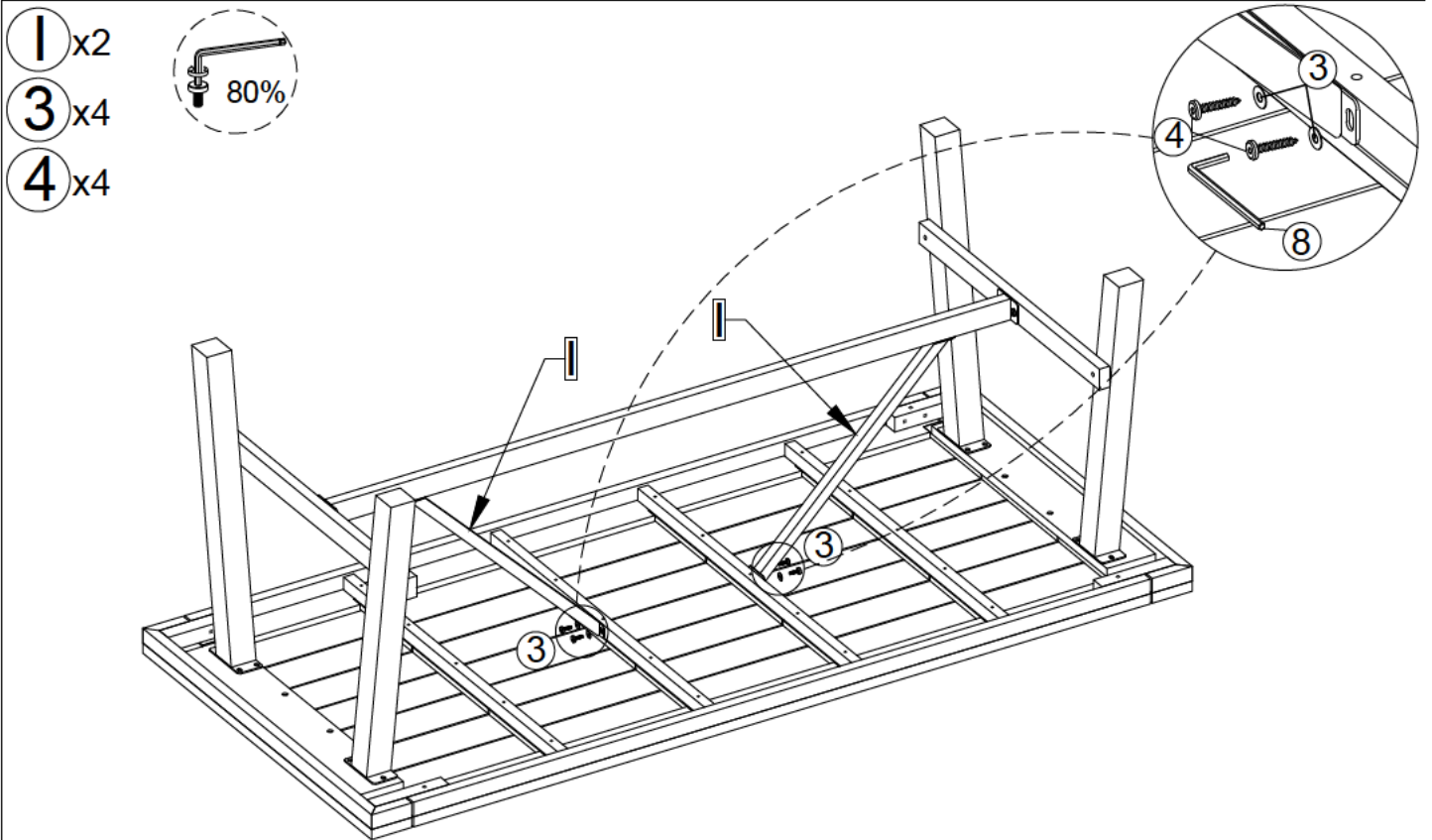

Step 5: Connect The Part from Step 4 & Support Table Leg (1), tighten Screw Bolt (4), Flat Washer (3) with Allen Key (8).

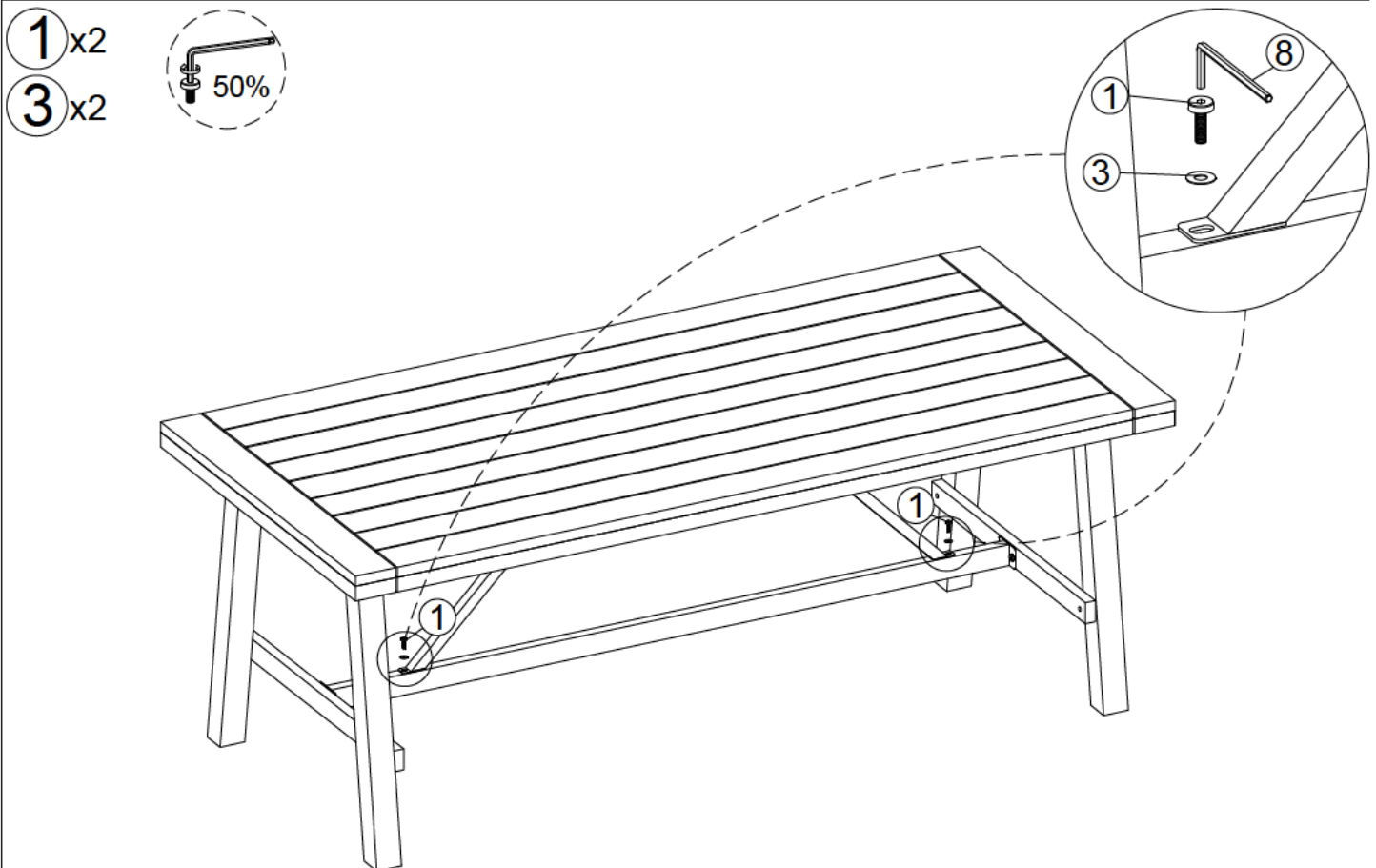

Step 6: Connect The Part from Step 5 , tighten Bolt (1), Flat Washer (6) with Allen Key (8).



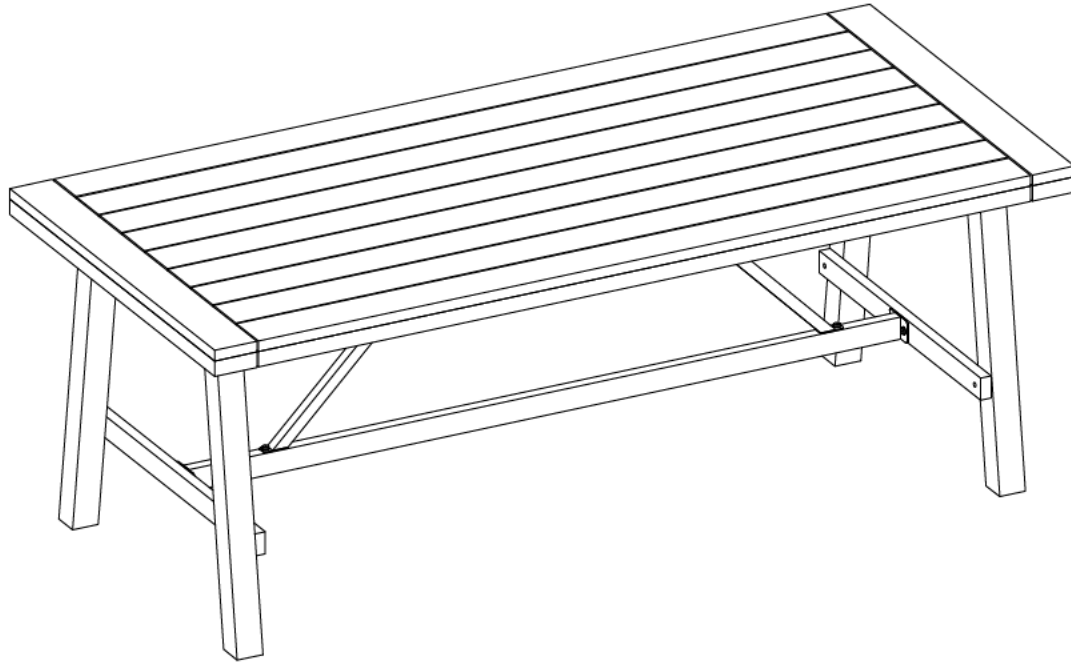
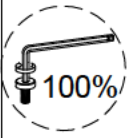

Step 7: Put the Table upright and make sure all legs are level, then firmly tighten Bolts with Allen Key (8).

**C** x1

**J** x2

**1** x 16

**3** x 16

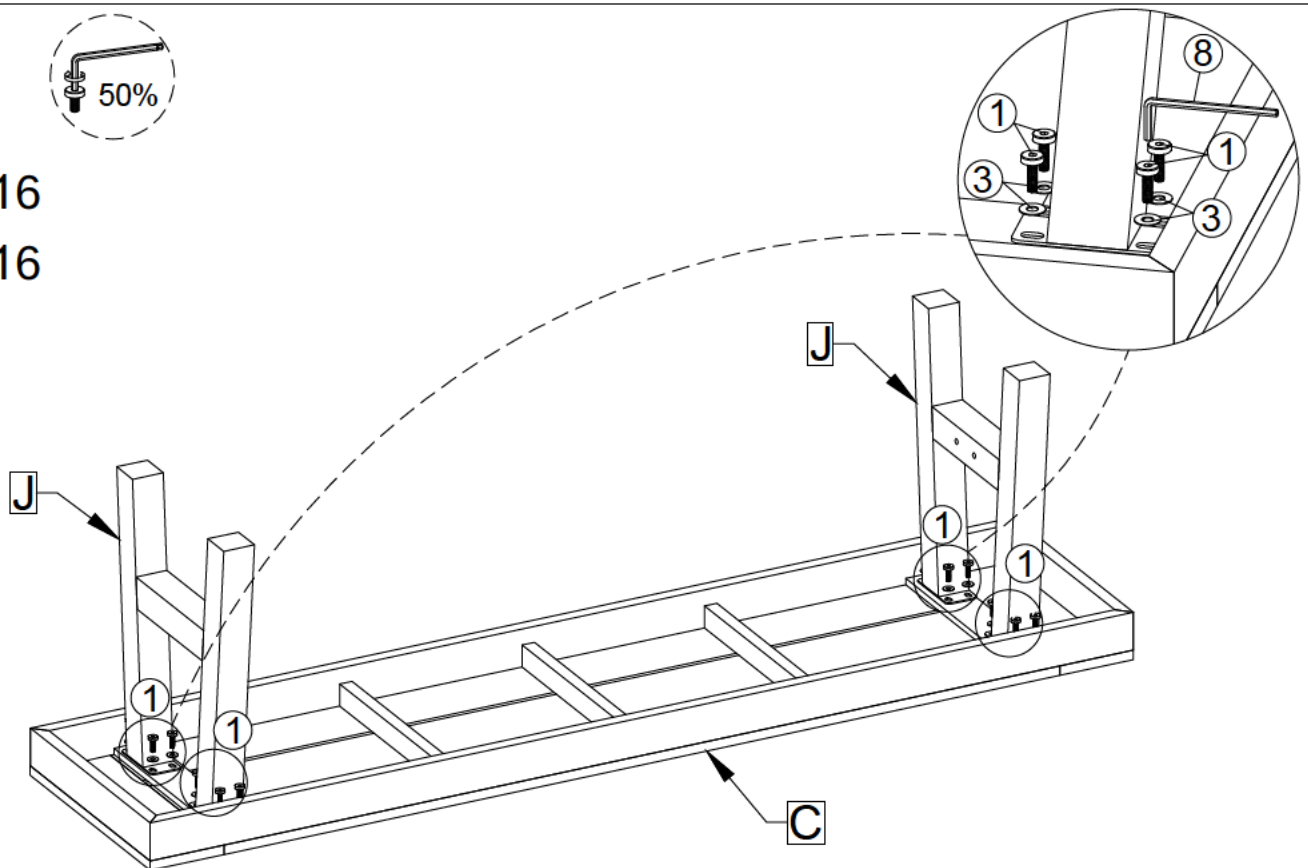

Step 8: Connect seat Bench (C) & Bench Leg (J), tighten Bolt (1), Flat Washer (3) with Allen Key (8).

**K**x1  
**1**x4  
**3**x4

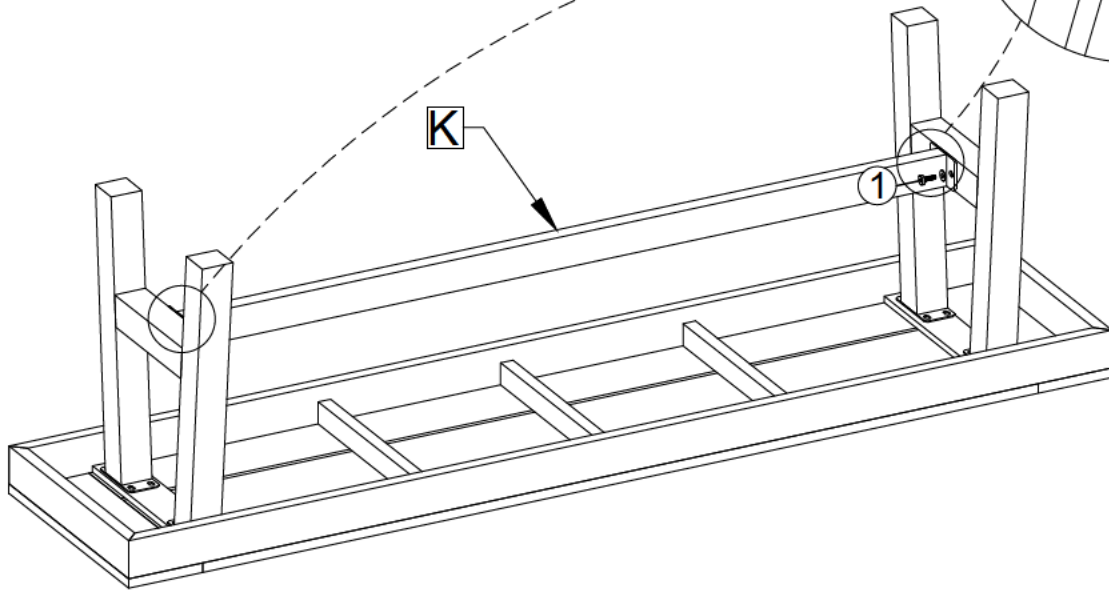
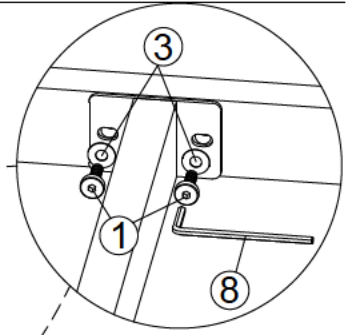

Step 9: Connect The Part from Step 8 & Support Bench Leg (K), tighten Bolt (1), Flat Washer (3) with Allen Key (8).

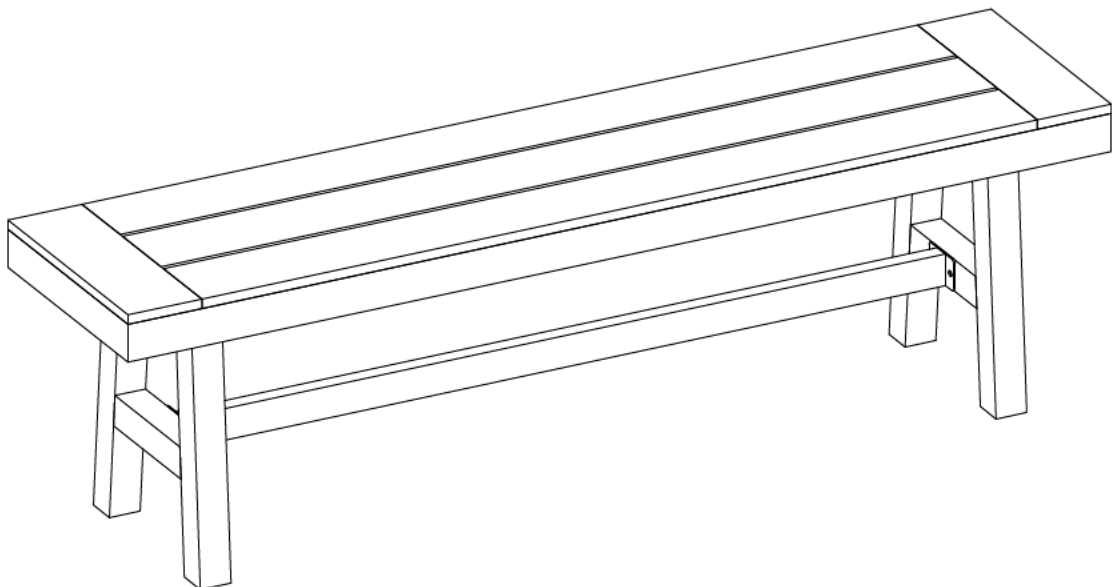
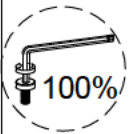

Step 10: Put the Bench upright and make sure all legs are level, then firmly tighten Bolts with Allen Key (8).

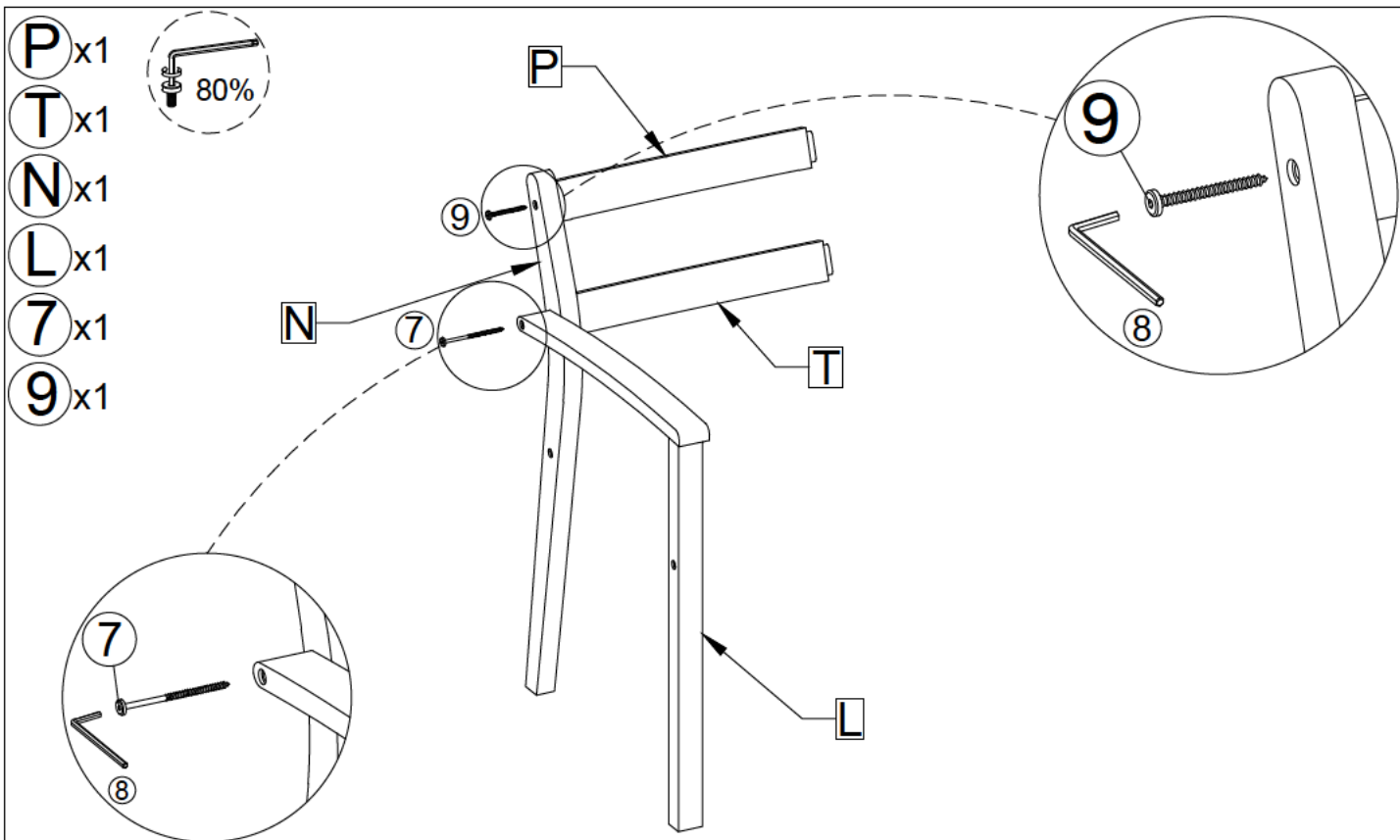

Step 11: Connect Arm Right (L) & Right Back Leg (N), Back Top (P), Back Bottom (T), tighten Screw Bolt (7),(9) with Allen Key (8).

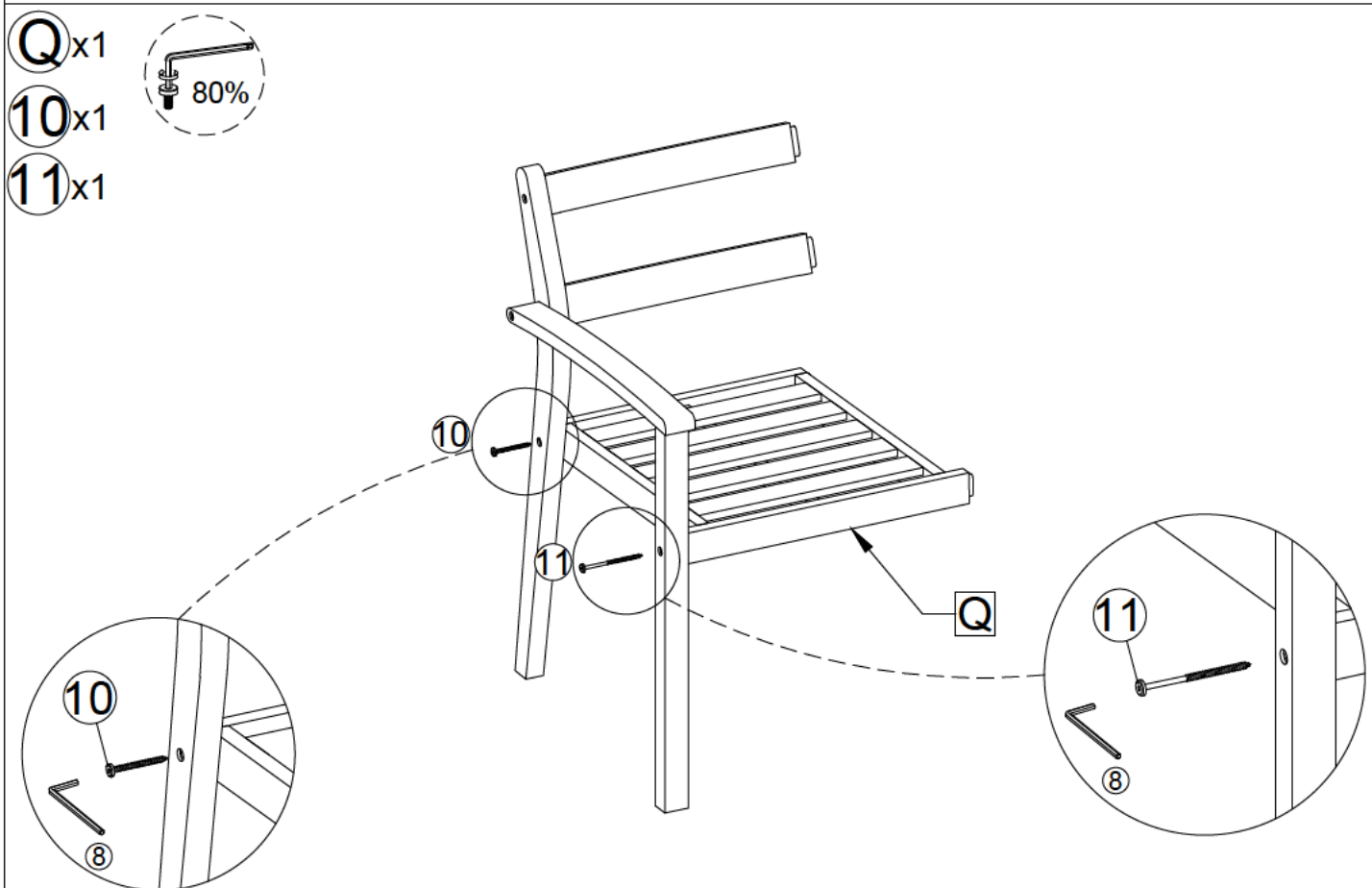

Step 12: Connect The Part from Step 11 & Seat (Q), tighten Screw Bolt (10),(11) with Allen Key (8).

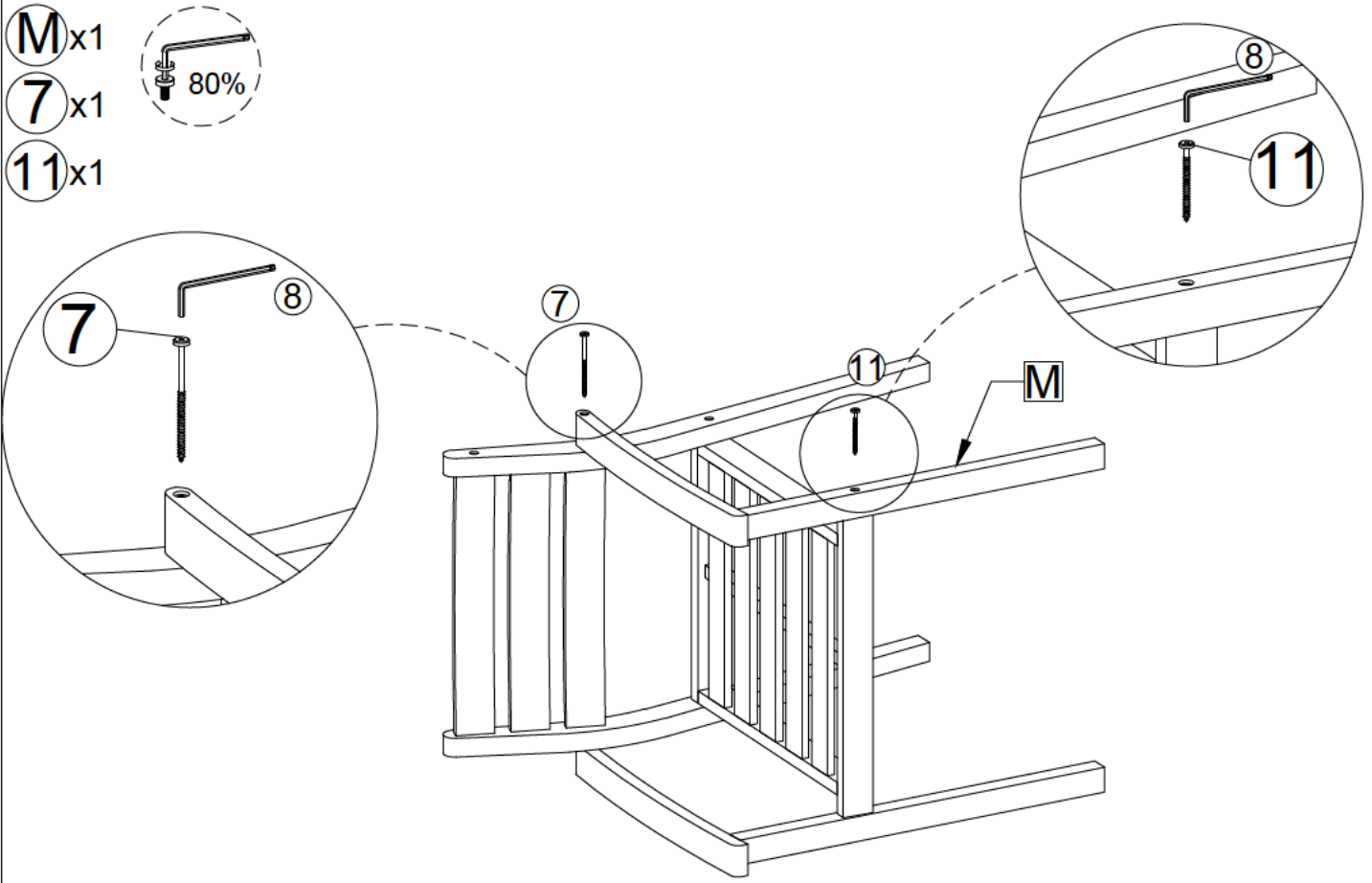
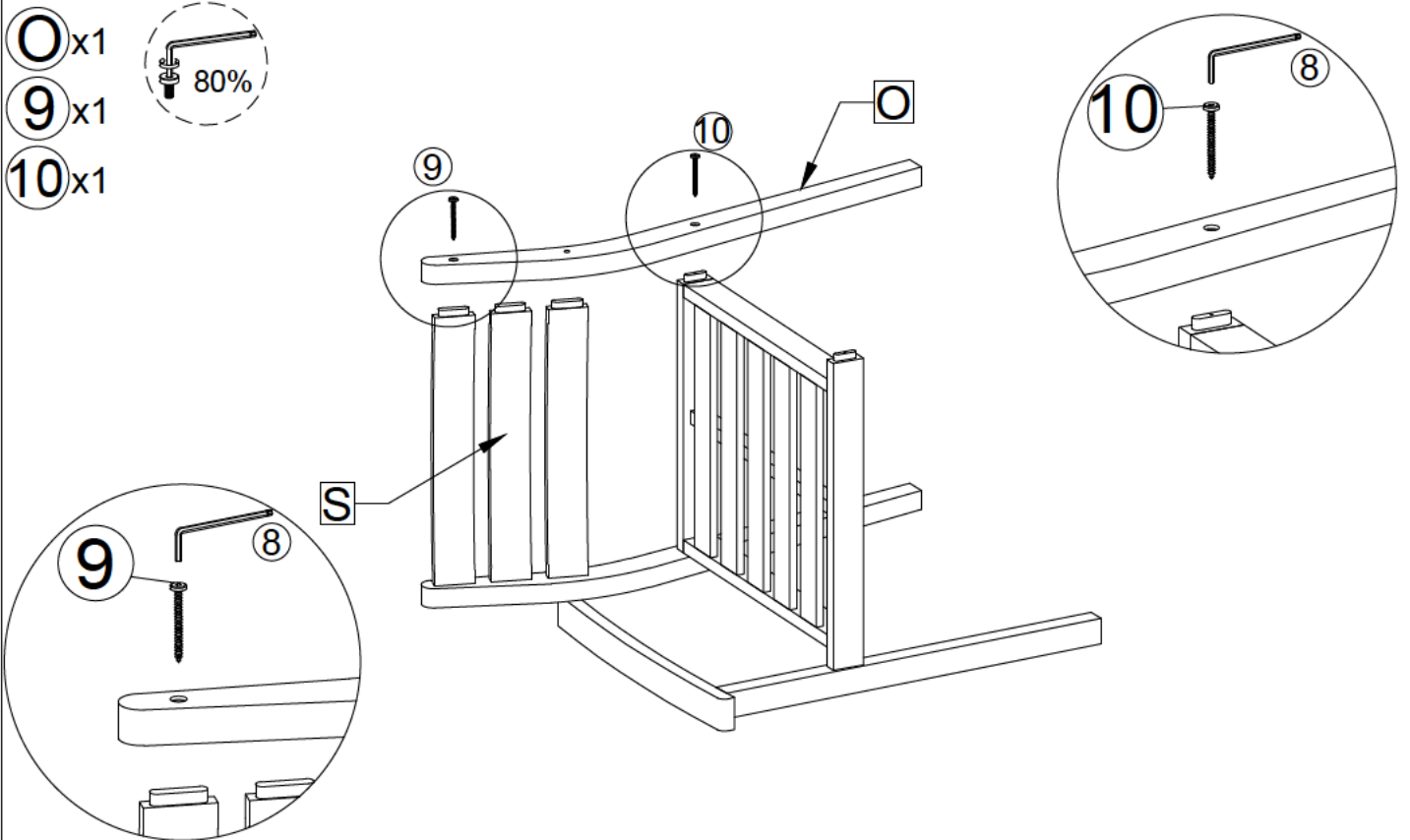

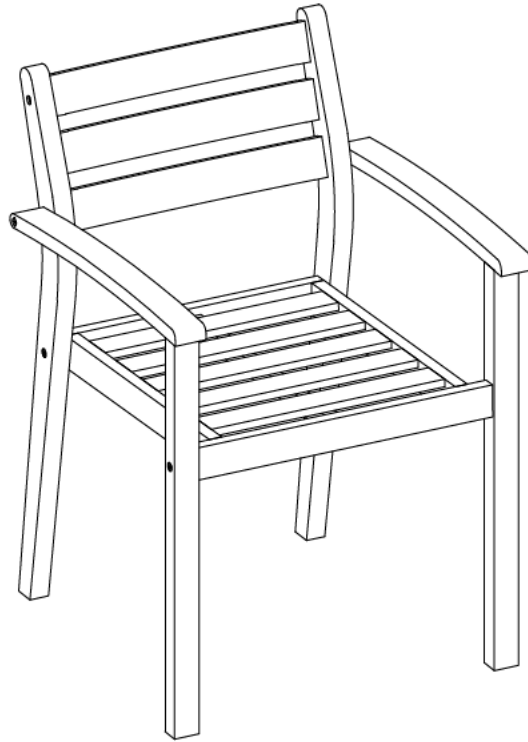
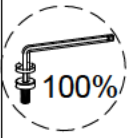

Step 14: Put the Chair upright and make sure all legs are level, then firmly tighten Bolts with Allen Key (8).

**R**x1

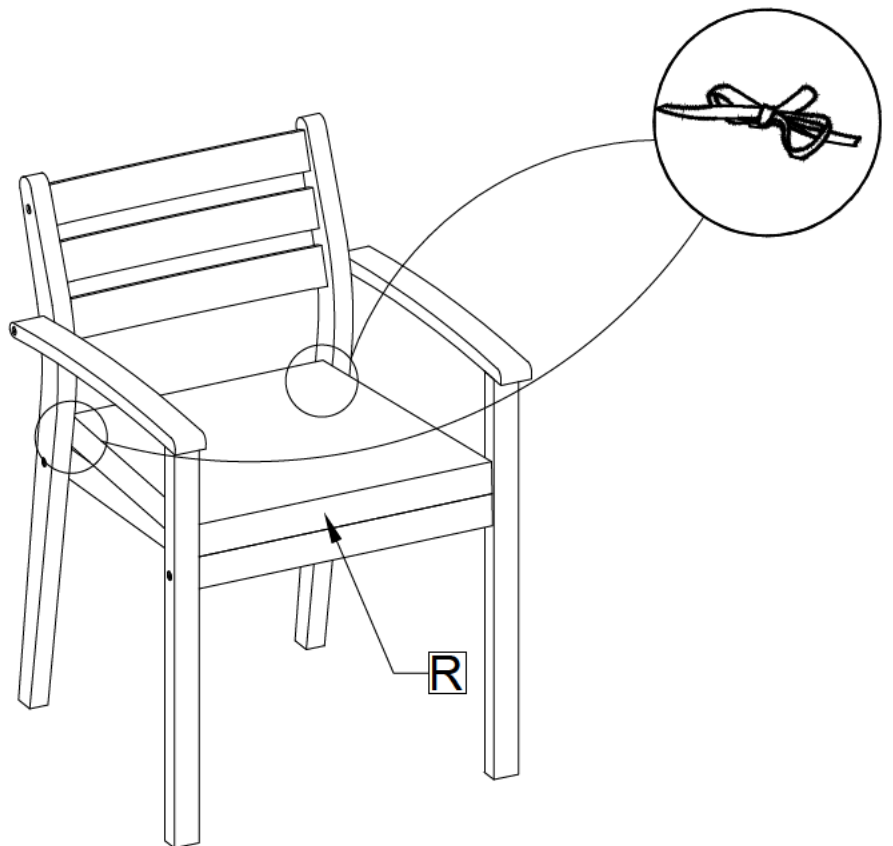

Step 15: Put on Seat Cushion (K) to finish Chair.