

Full Bed

Assembly Instructions

1 Assembled View

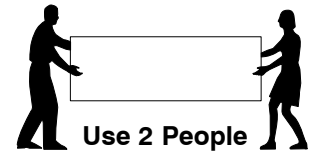
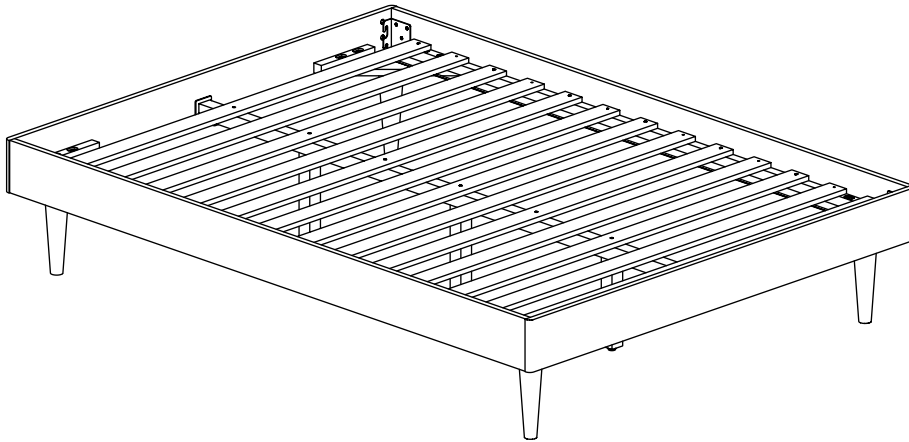

Note: Do not assemble using power tools. This can cause the bolts to be overtightened

2 Parts List

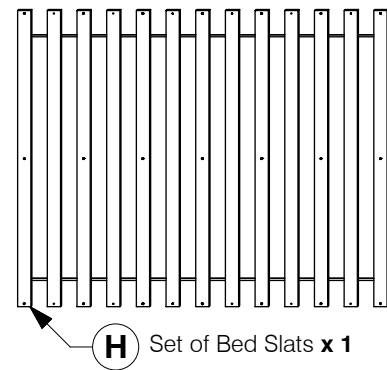
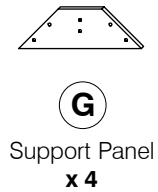
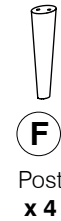
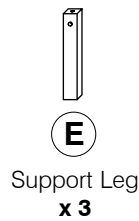
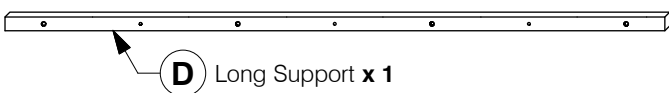
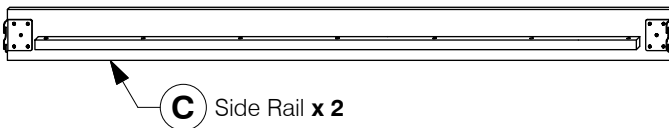
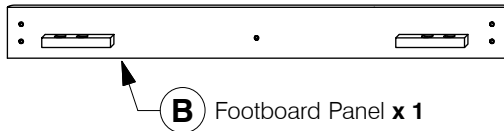
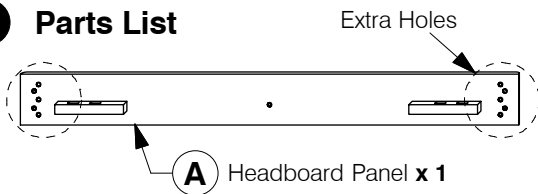

3 Hardware List

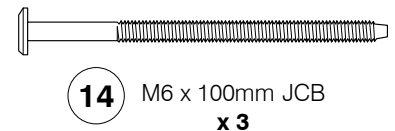
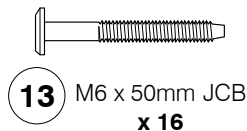
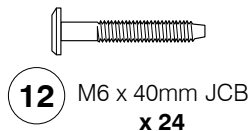
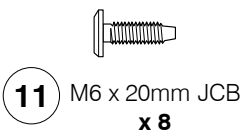
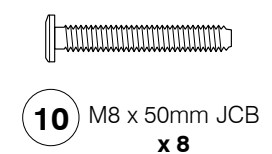
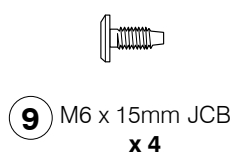
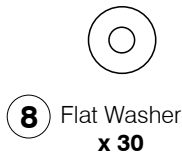
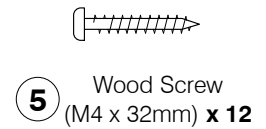
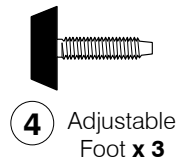
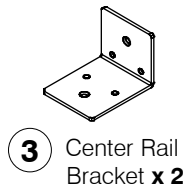
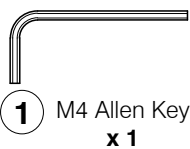

Full Bed

Assembly Instructions

- 4** Fix the Adjustable foot to the bottom of the Support Leg (E).

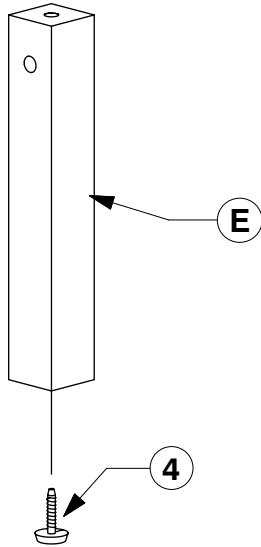

- 5** Fit the Post (F) to the Support Panel (G).

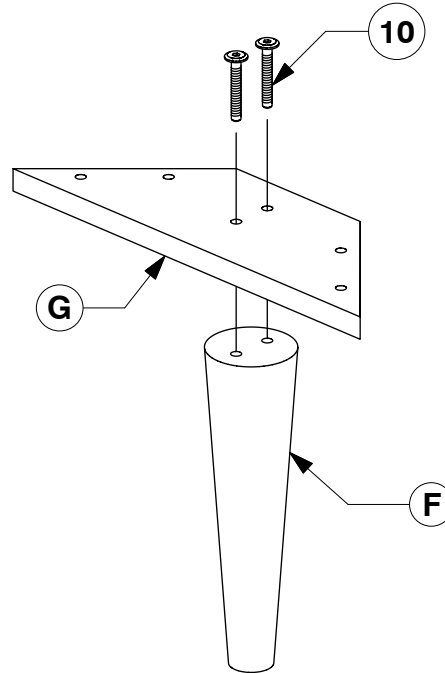

- 6** Fit the Center Rail Bracket to the Headboard Panel (A).

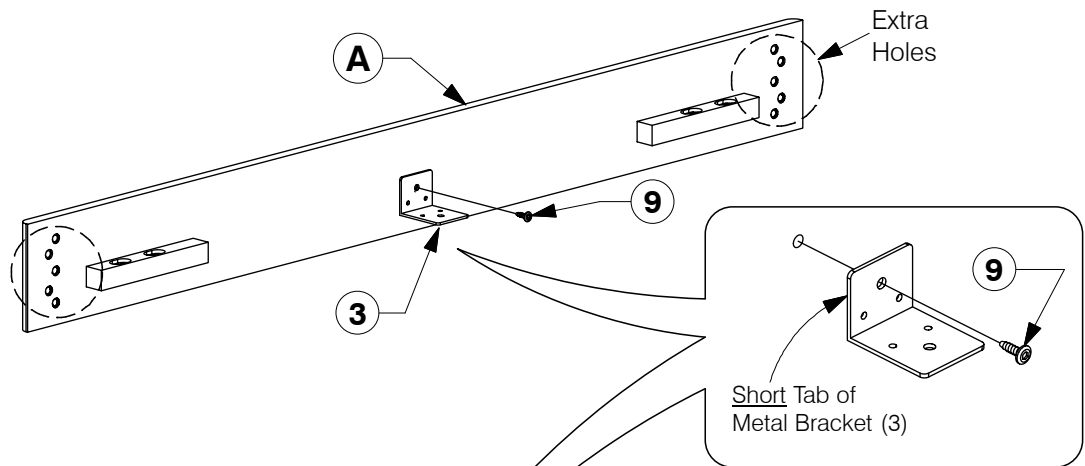

- 7** Fit the Center Rail Bracket to the Footboard Panel (B).

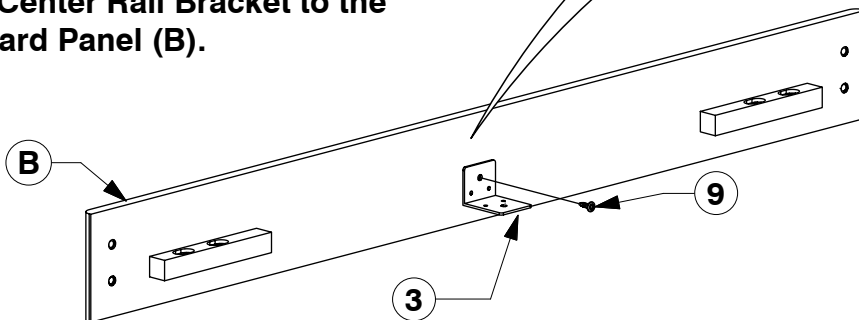

Full Bed

Assembly Instructions

- 8** Bolt the assembled Support Panel (G) to the Side Rail (C).

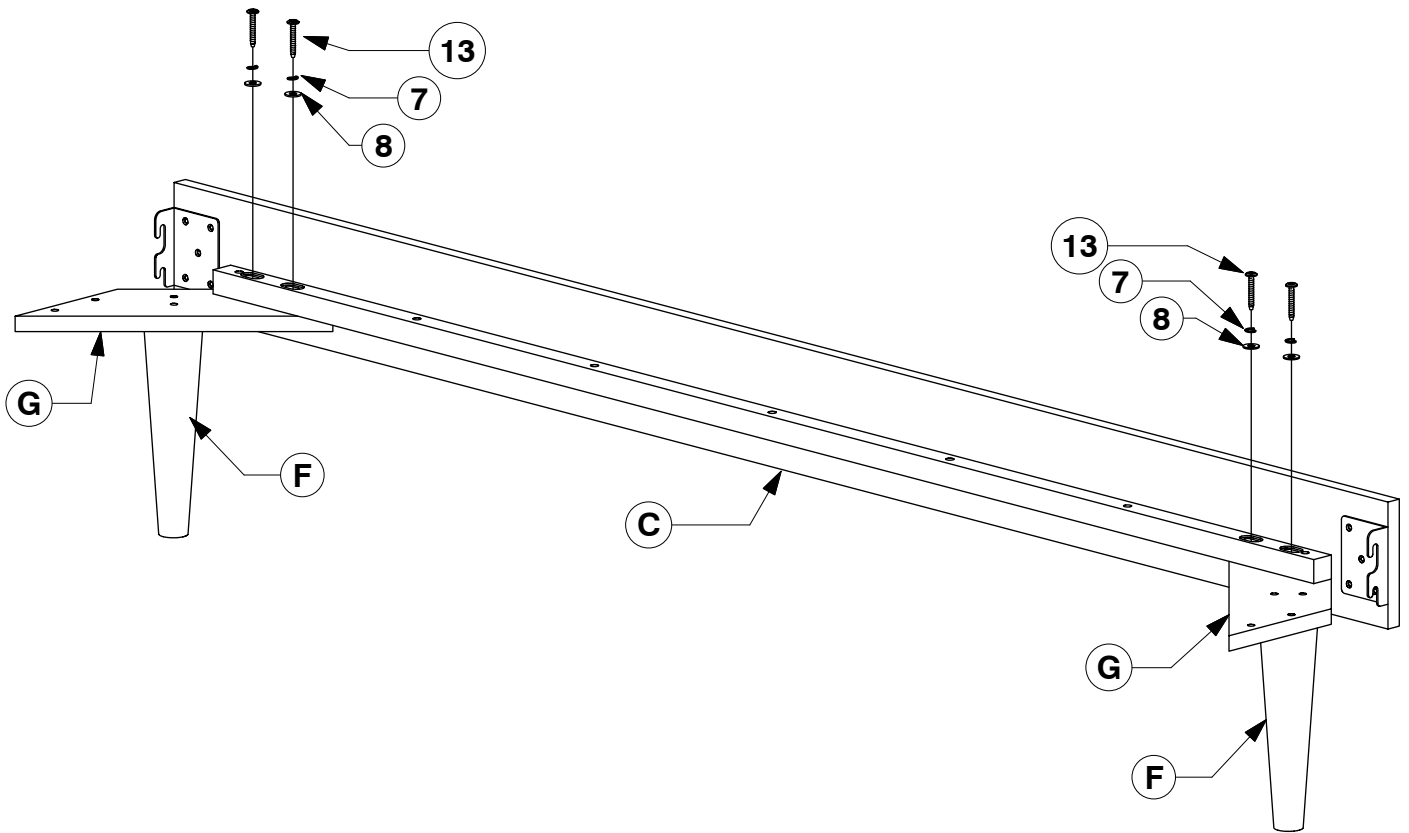

- 9** Assemble the Side Rail (C) to the Headboard and Footboard Panel (A & B).

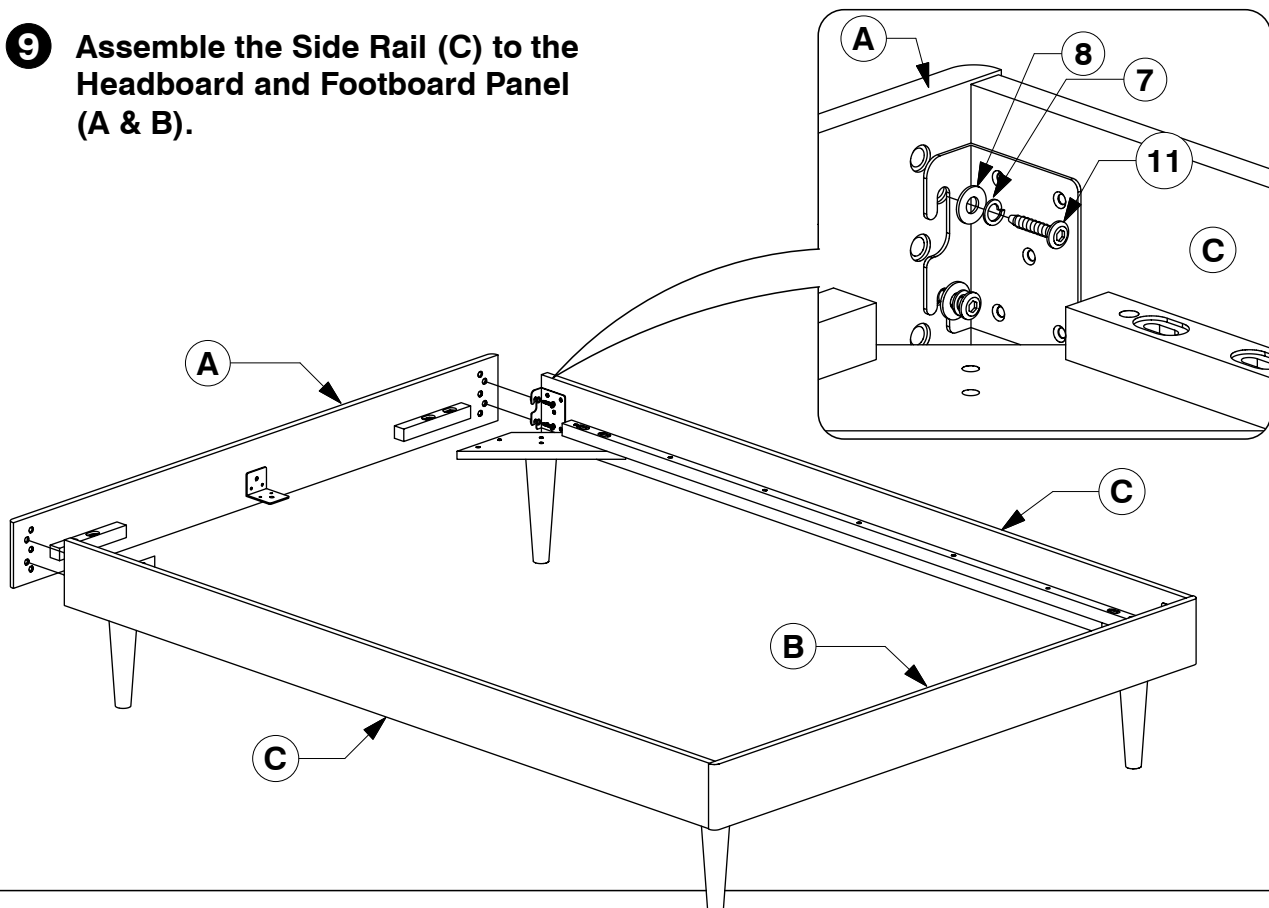

Full Bed

Assembly Instructions

- 10** Bolt the assembled Support Panel (G) to the Headboard and Footboard Panel (A & B).

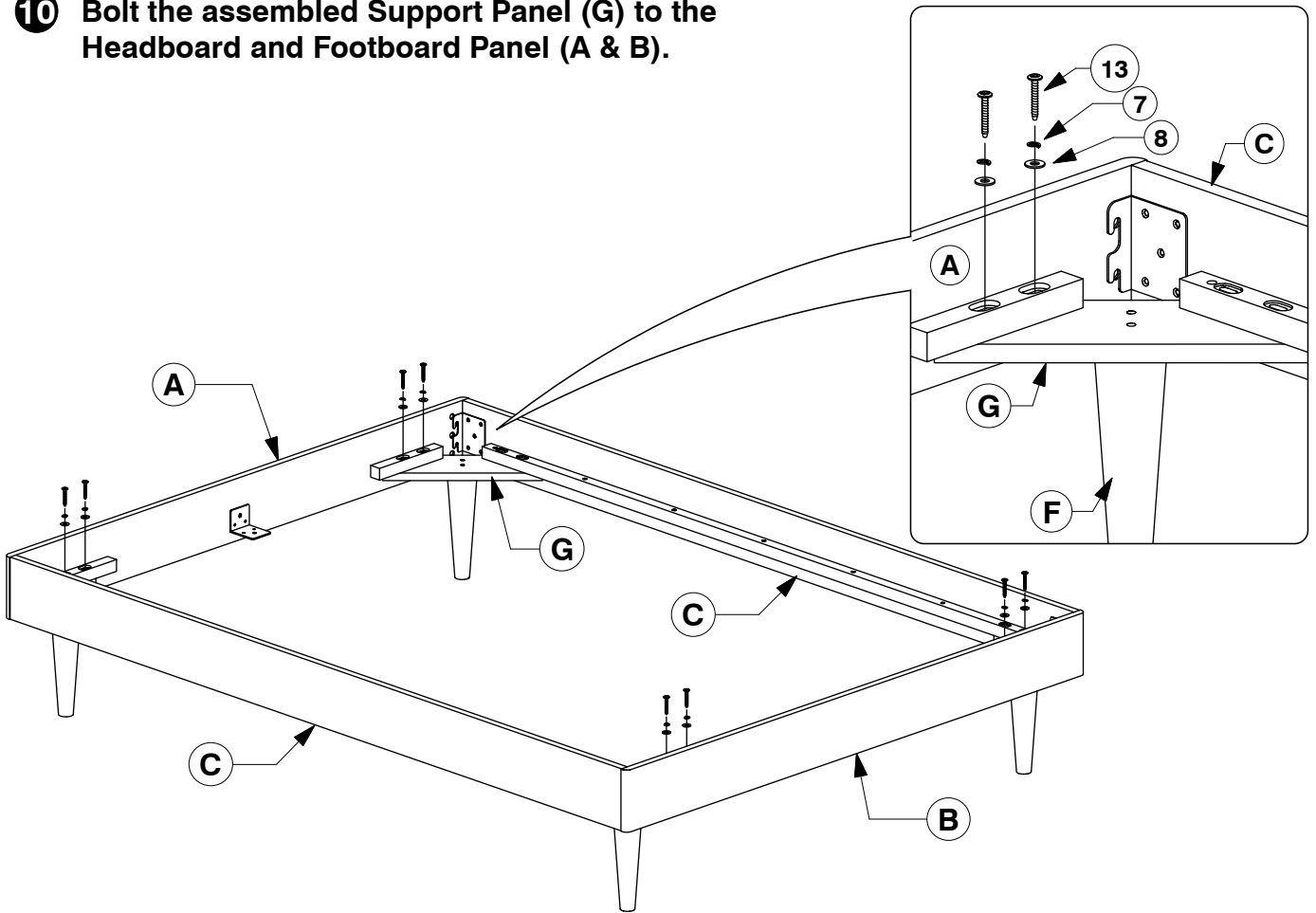

- 11** Bolt the Long Support (D) to the Center Rail Brackets (3) on the Headboard and Footboard Panel (A & B).

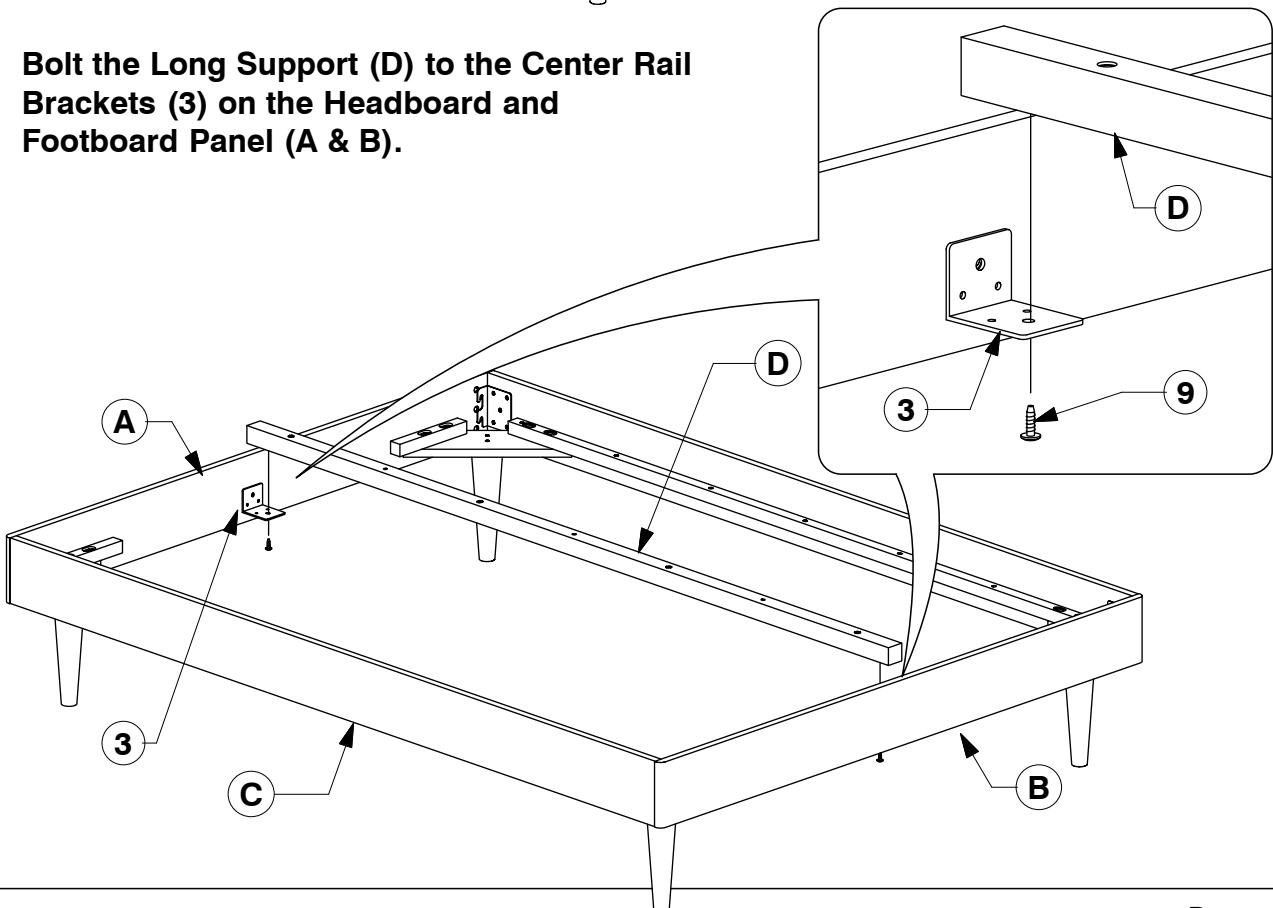

Full Bed

Assembly Instructions

- 12** Fit the first 3 Slats and assemble the Support Leg (E) to the Bed Slat (H). Bolt & screw the Bed Slats (H) to the Side Rail (C) & Long Support (D).

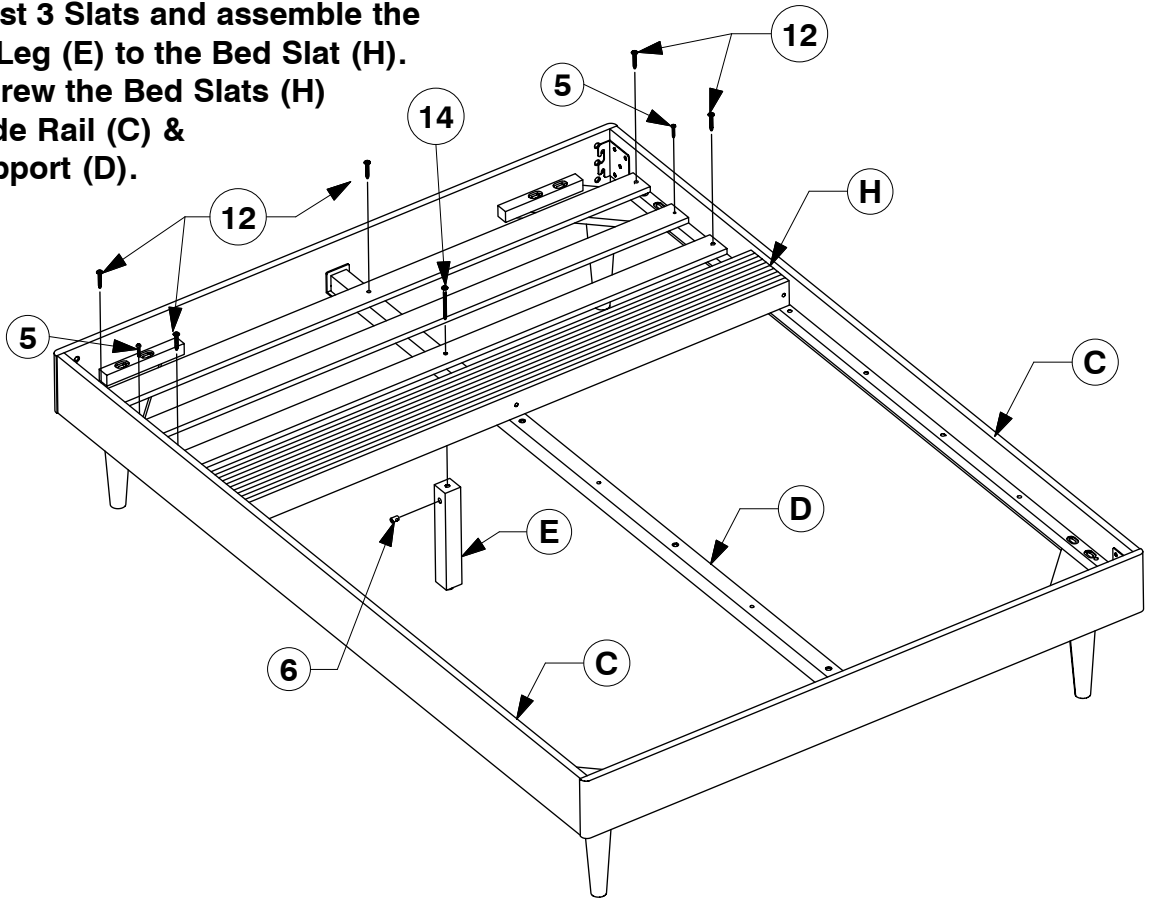

- 13** Fit the other Slats out and assemble the Support Leg (E) to the Bed Slat (H). Bolt & screw the Bed Slats (H) to the Side Rail (C) & Long Support (D).

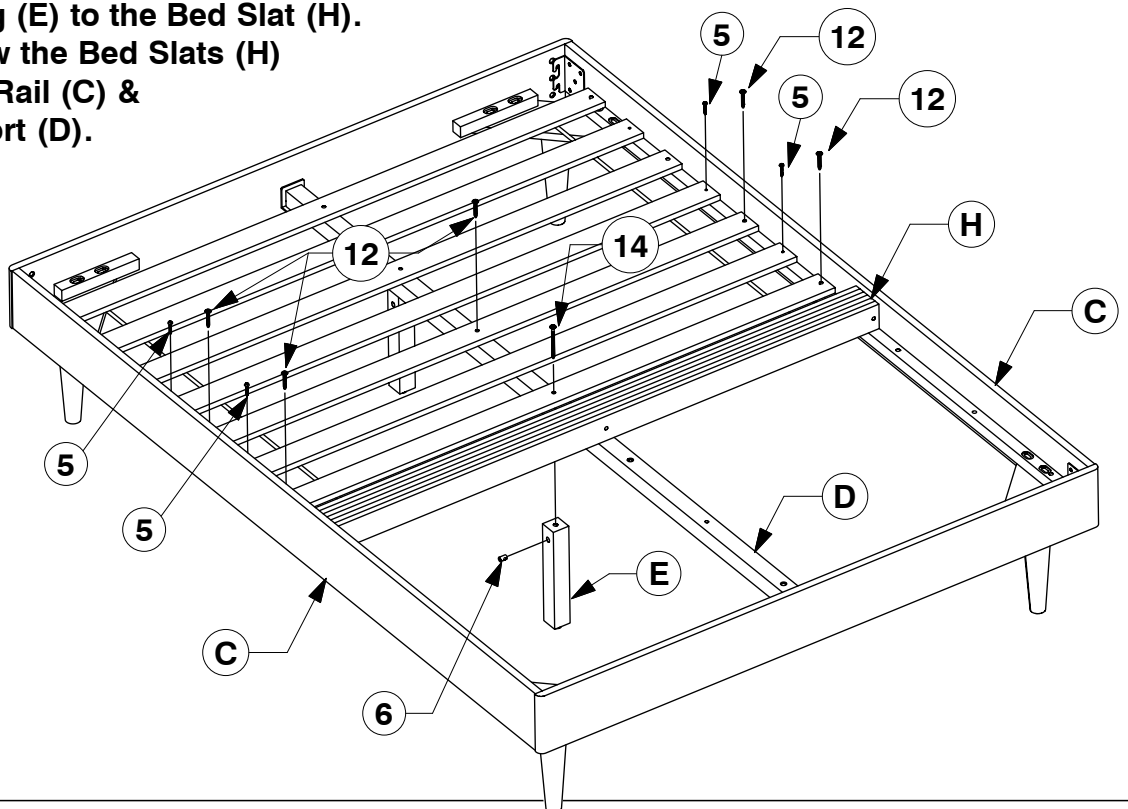

Full Bed

Assembly Instructions

- 14** Fit the other Slats out and assemble the Support Leg (E) to the Bed Slat (H). Bolt & screw the Bed Slats (H) to the Side Rail (C) & Long Support (D).

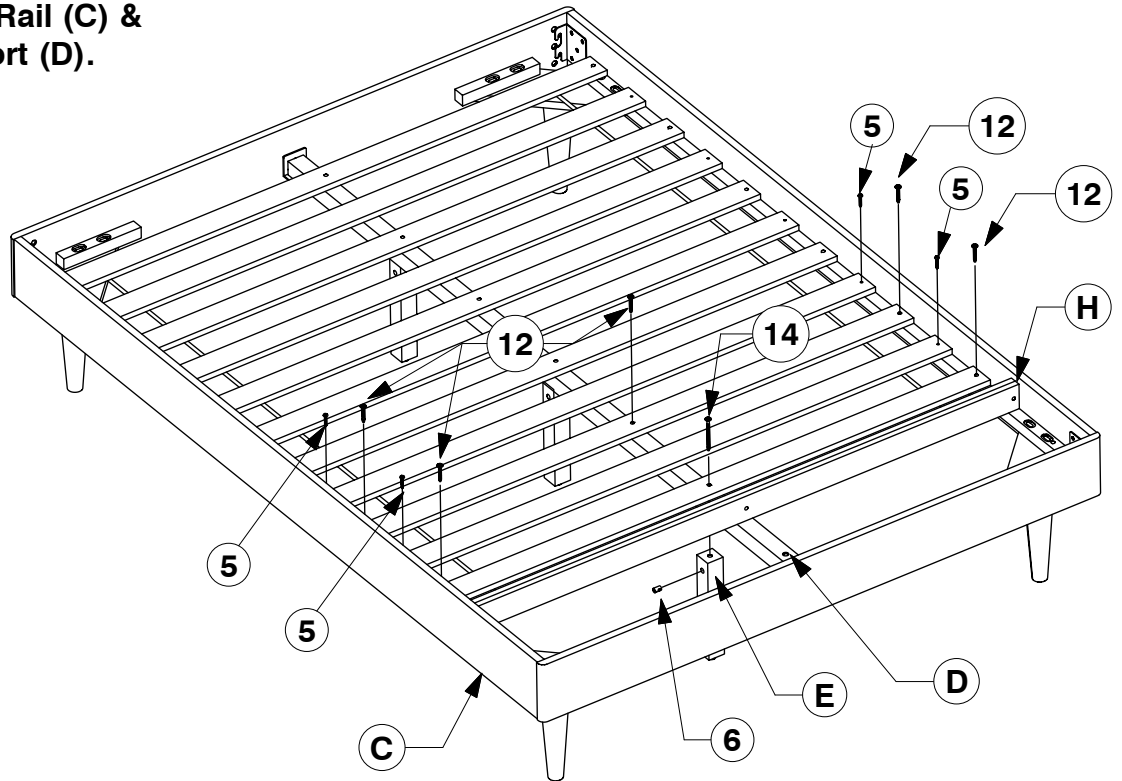

- 15** Bolt & screw the remaining Bed Slats (H) to the Side Rail (C).

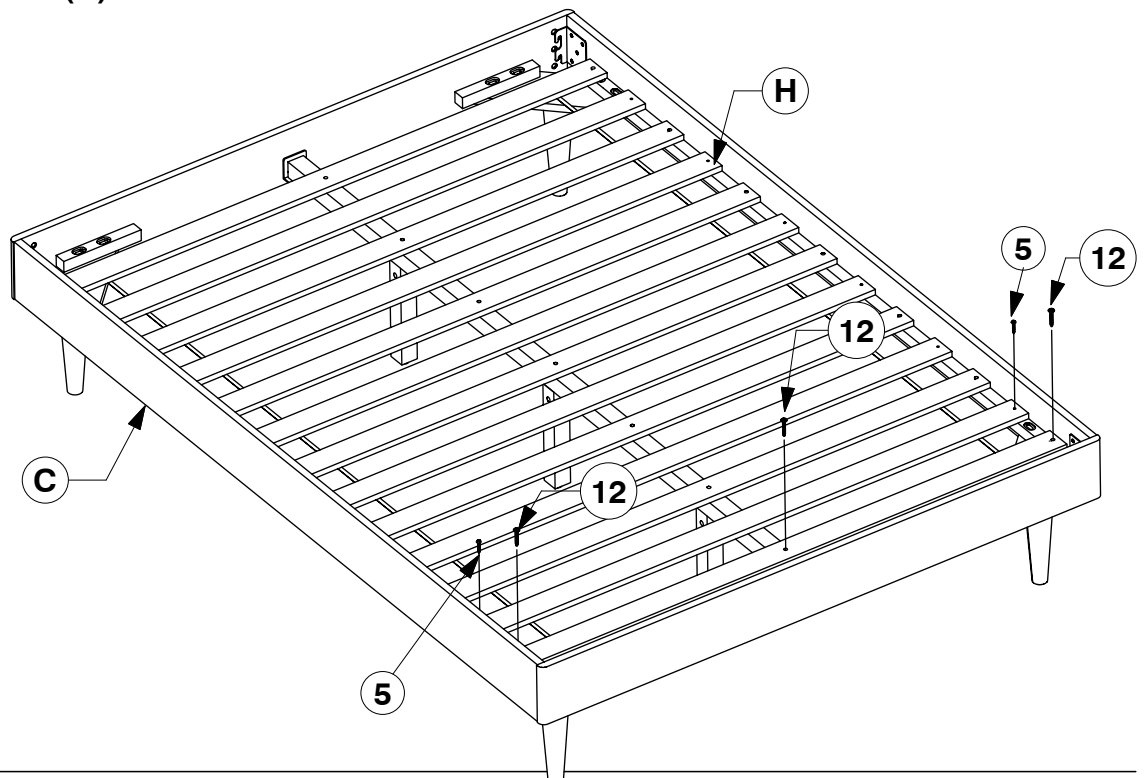

Full Headboard

Assembly Instructions

1 Parts List

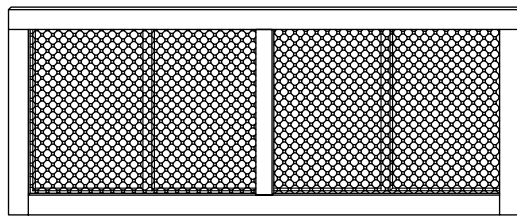
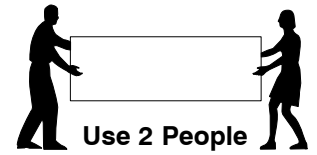

A Headboard Panel x 1

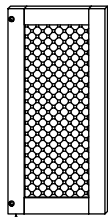

B Headboard Side Panel (Left hand) x 1

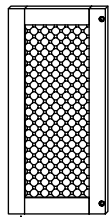

C Headboard Side Panel (Right hand) x 1

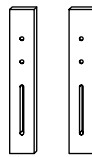

D Support Bar x 2



Note: Do not assemble using power tools. This can cause the bolts to be overtightened

2 Hardware List



1 M6 x 60mm JCB x 4

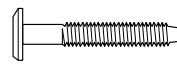

2 M6 x 35mm JCB x 4



3 Barrel Nut x 4



4 Wood Dowel (M10 x 40mm) x 4



5 Spring Washer x 4



6 Flat Washer x 4



7 M4 Allen Key x 1

3 Fit the Headboard Side Panel (B & C) to the Headboard Panel (A).

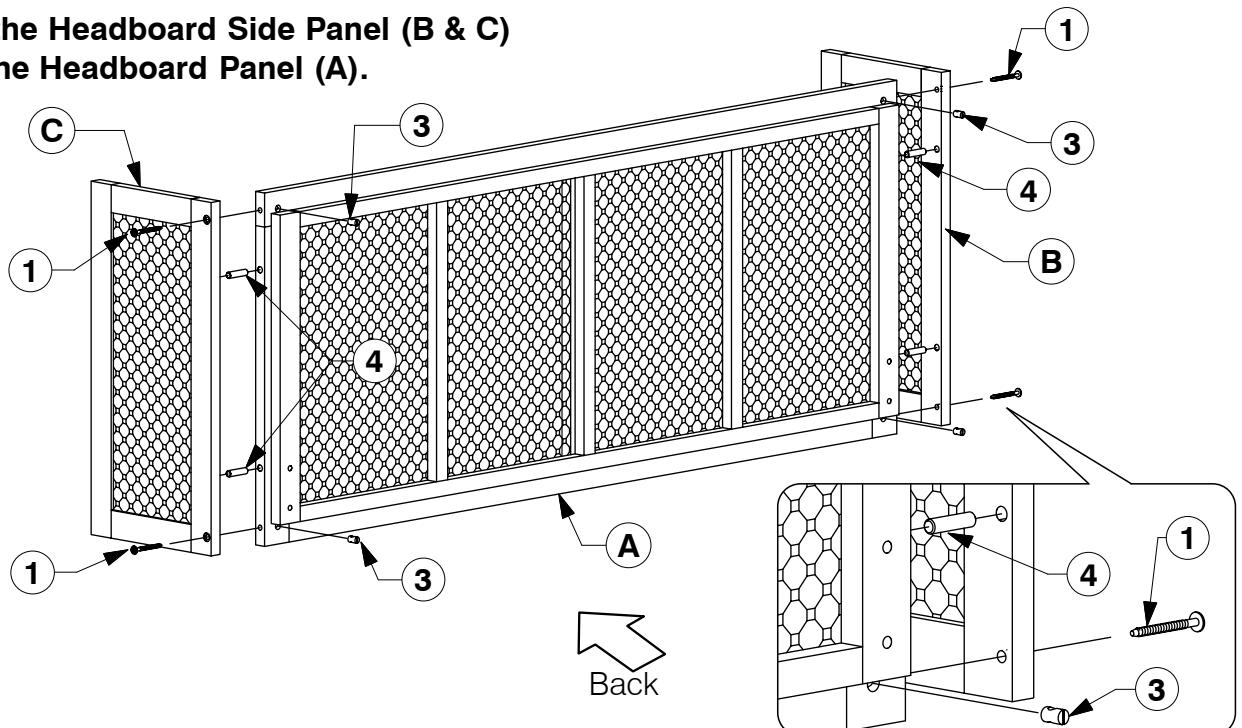

Full / Queen Headboard

Assembly Instructions

4 Assemble the Support Bars (D) to the Headboard Panel.

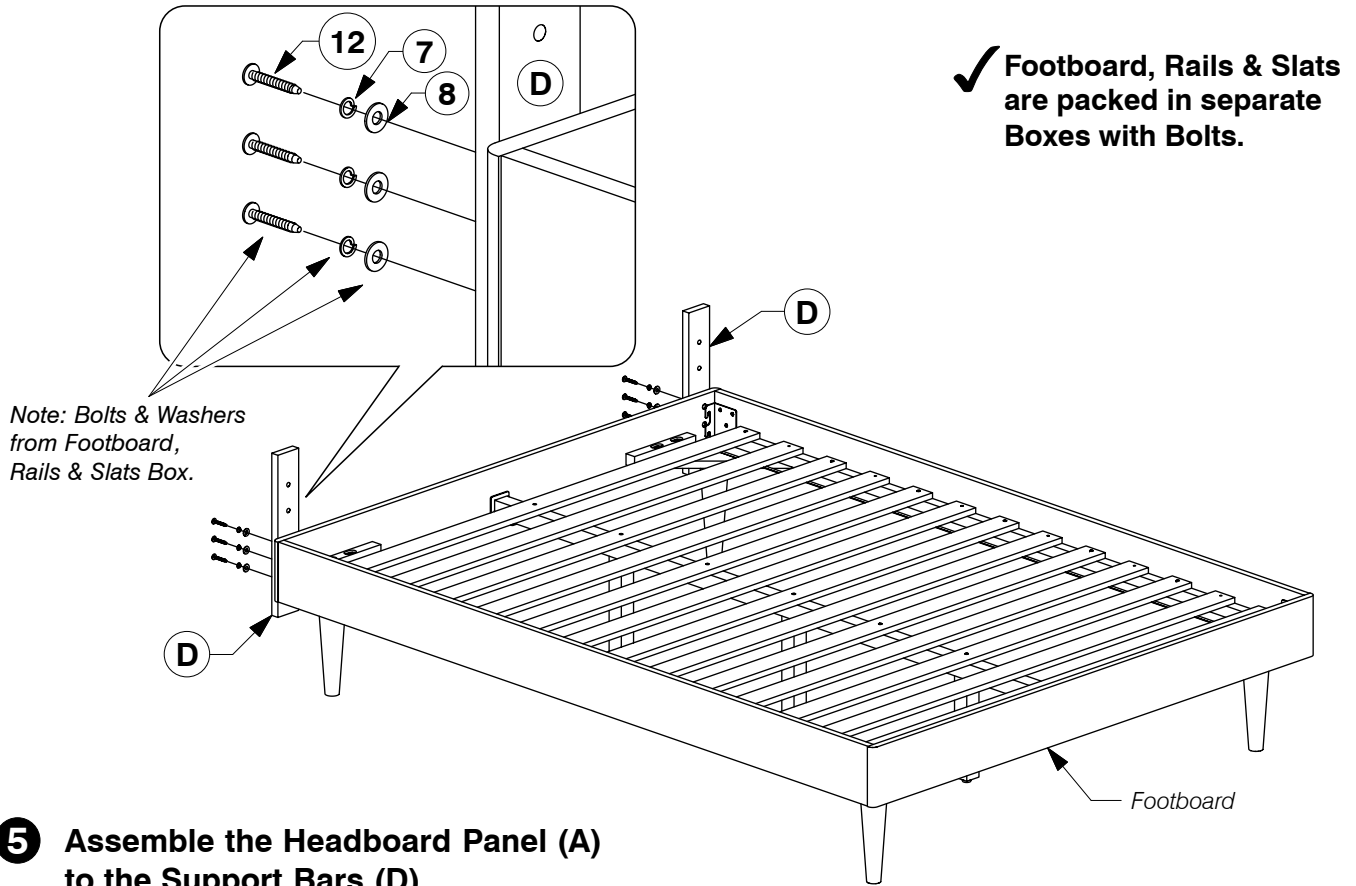

5 Assemble the Headboard Panel (A) to the Support Bars (D).

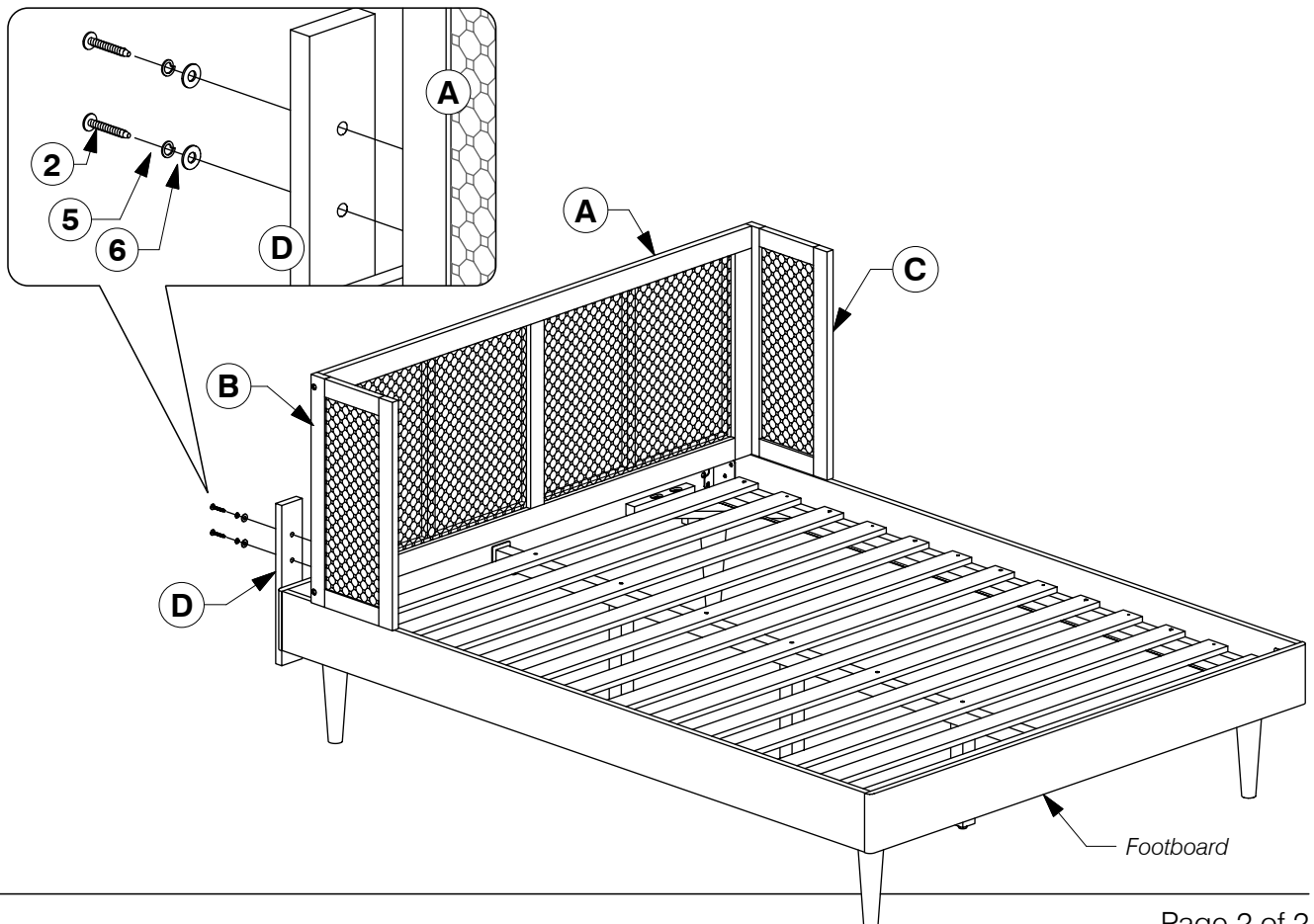

2 Drawer Nightstand

Assembly Instructions

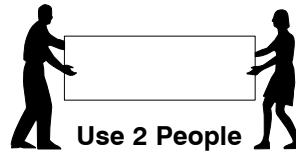
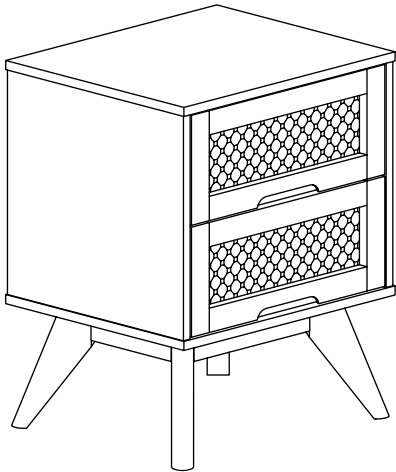

Note: Do not assemble using power tools. This can cause the bolts to be overtightened

1 Parts List

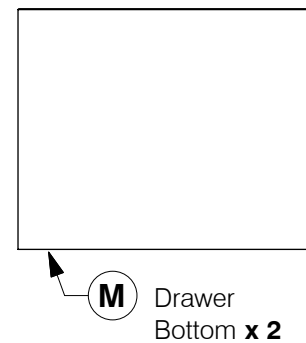
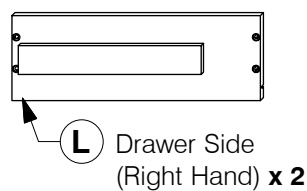
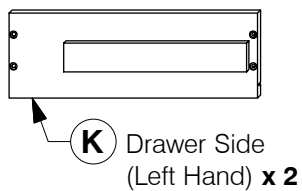
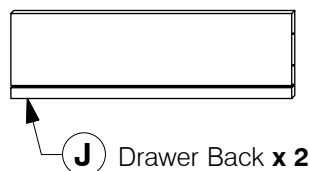
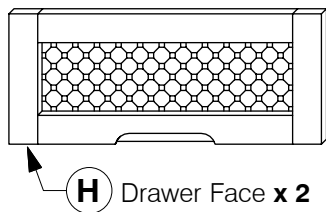
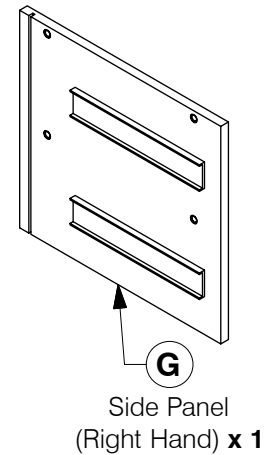
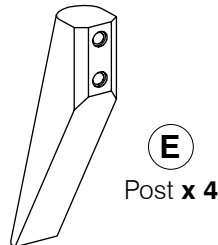
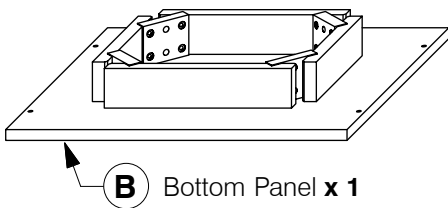
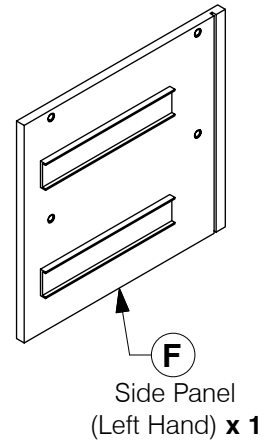
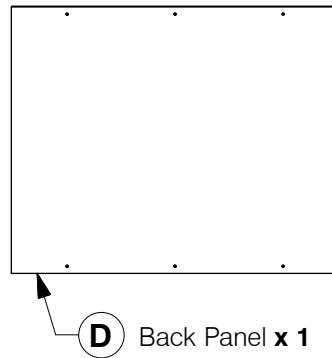
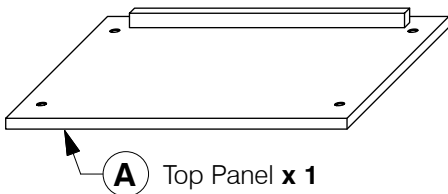

2 Drawer Nightstand

Assembly Instructions

2 Hardware List

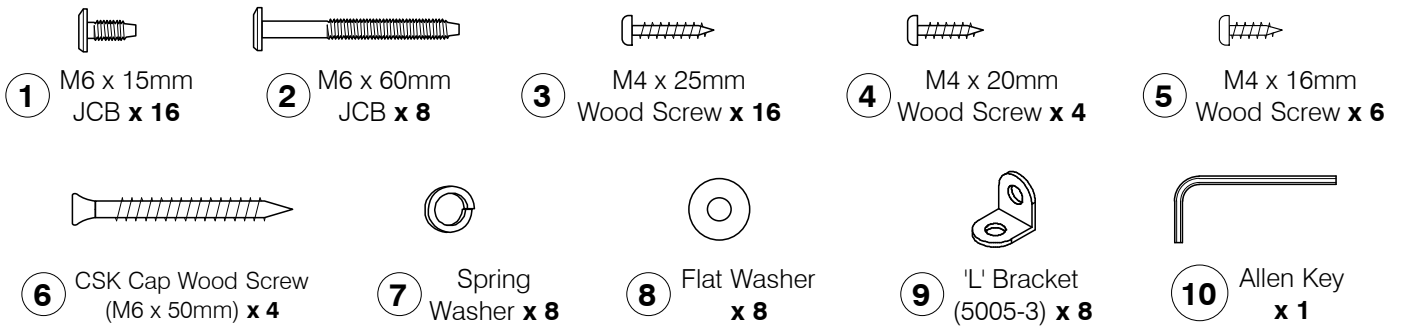

3 Assemble the Drawer Sides (K & L) to the Drawer Face (H).

x2

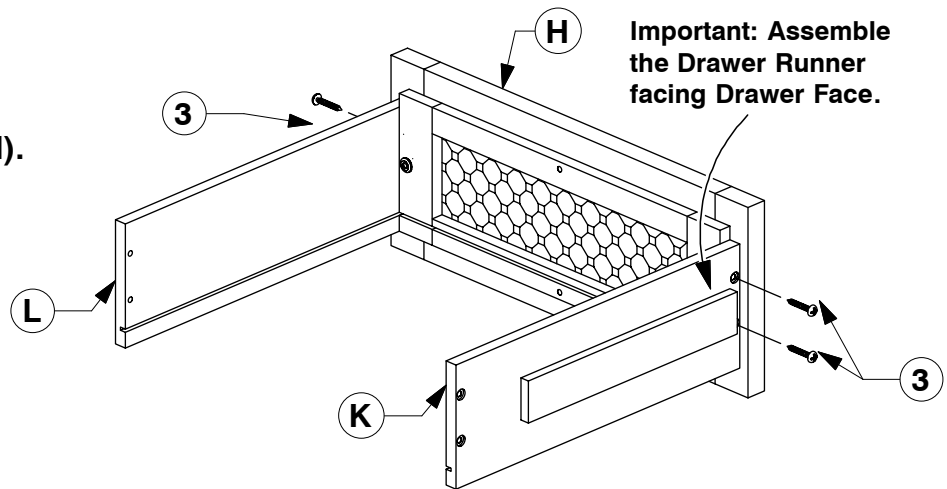

4 Slide the Drawer Bottom (M) into the groove on the Drawer Sides (K & L).

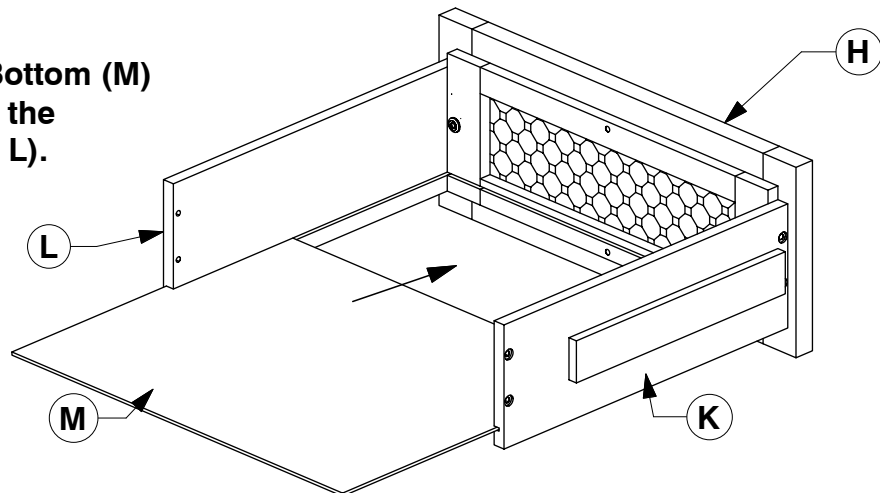

5 Assemble the Drawer Back (J) to the Drawer Sides (K & L).

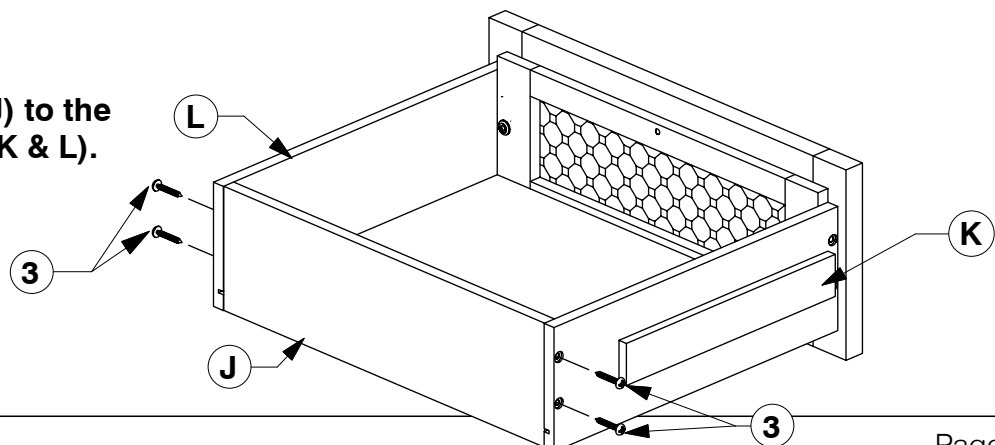

2 Drawer Nightstand

Assembly Instructions

6 Fit the 'L' Bracket to the Side Panel (F & G).

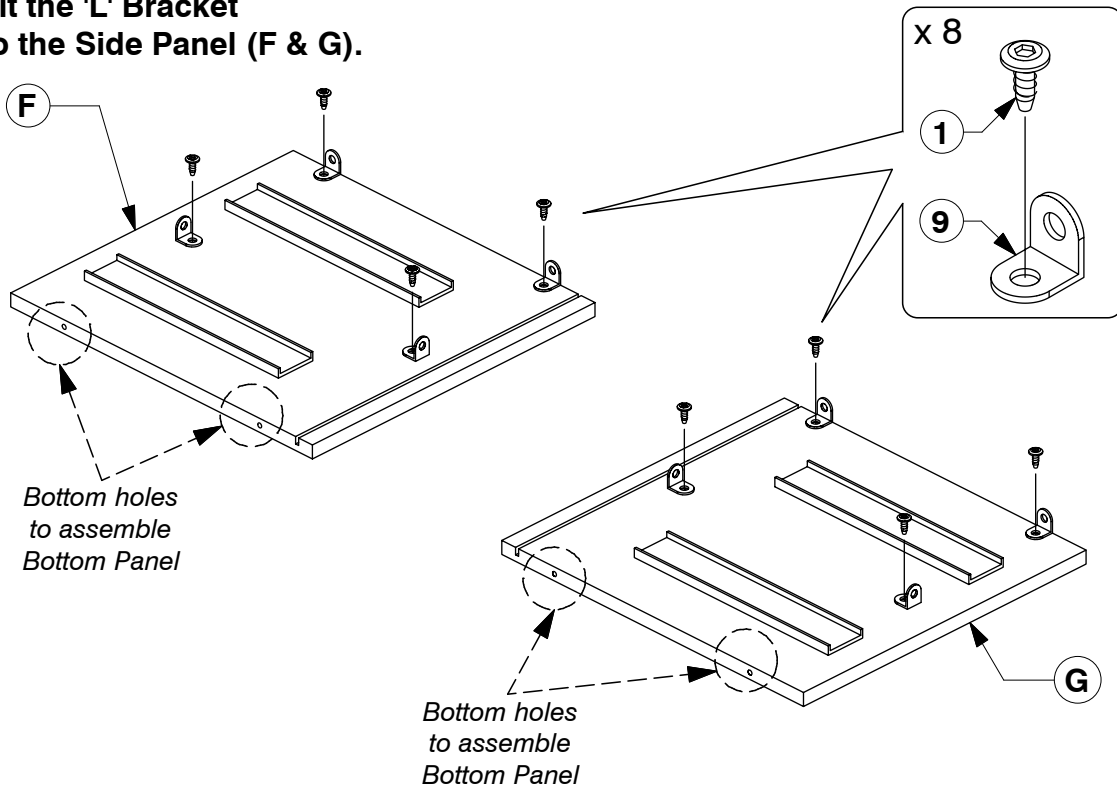

7 Assembled the Side Panel (F & G) to the Top Panel (A).

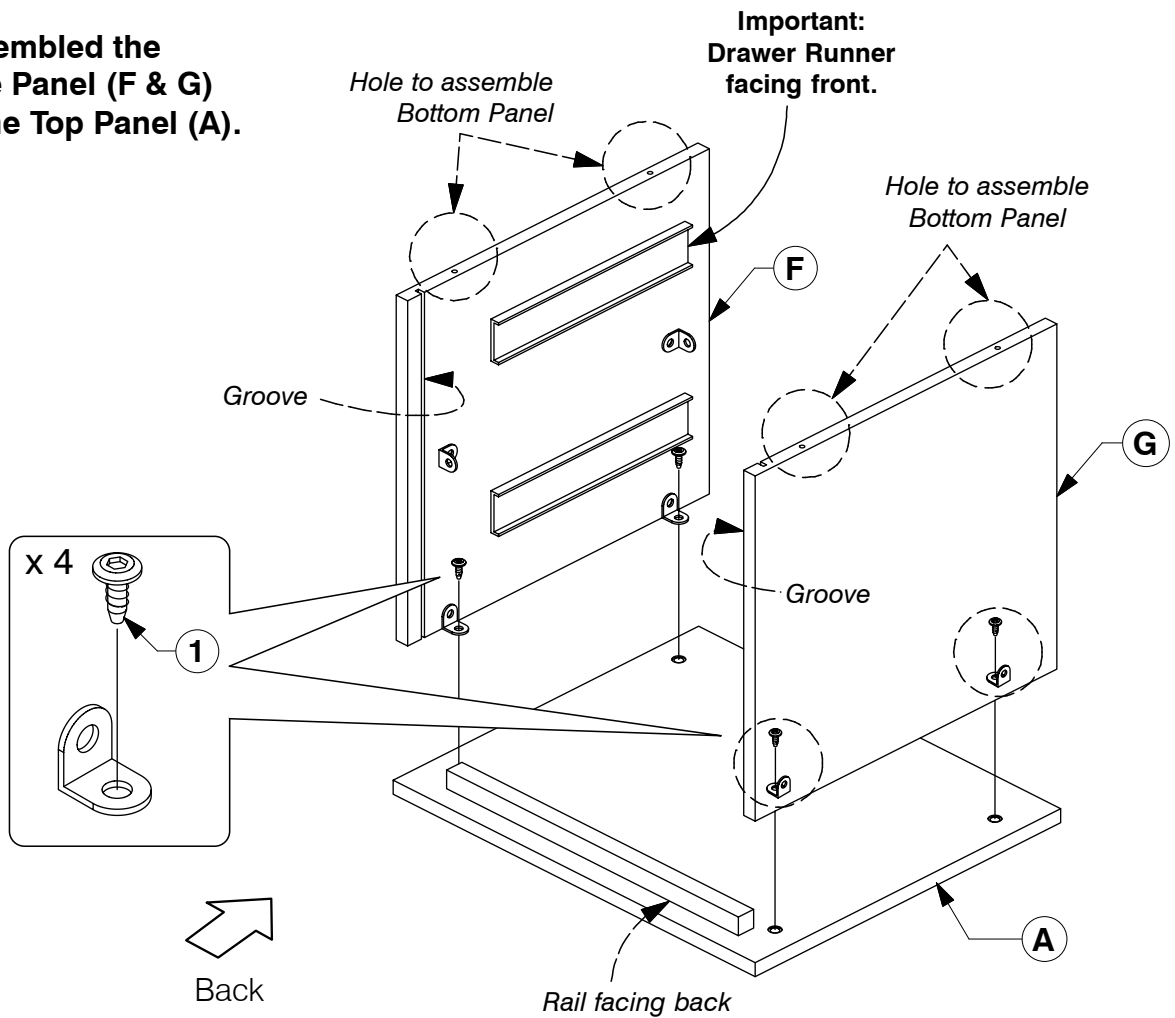

2 Drawer Nightstand

Assembly Instructions

- 8** Fit the Support Bar (C) to the Side Panel (F & G).

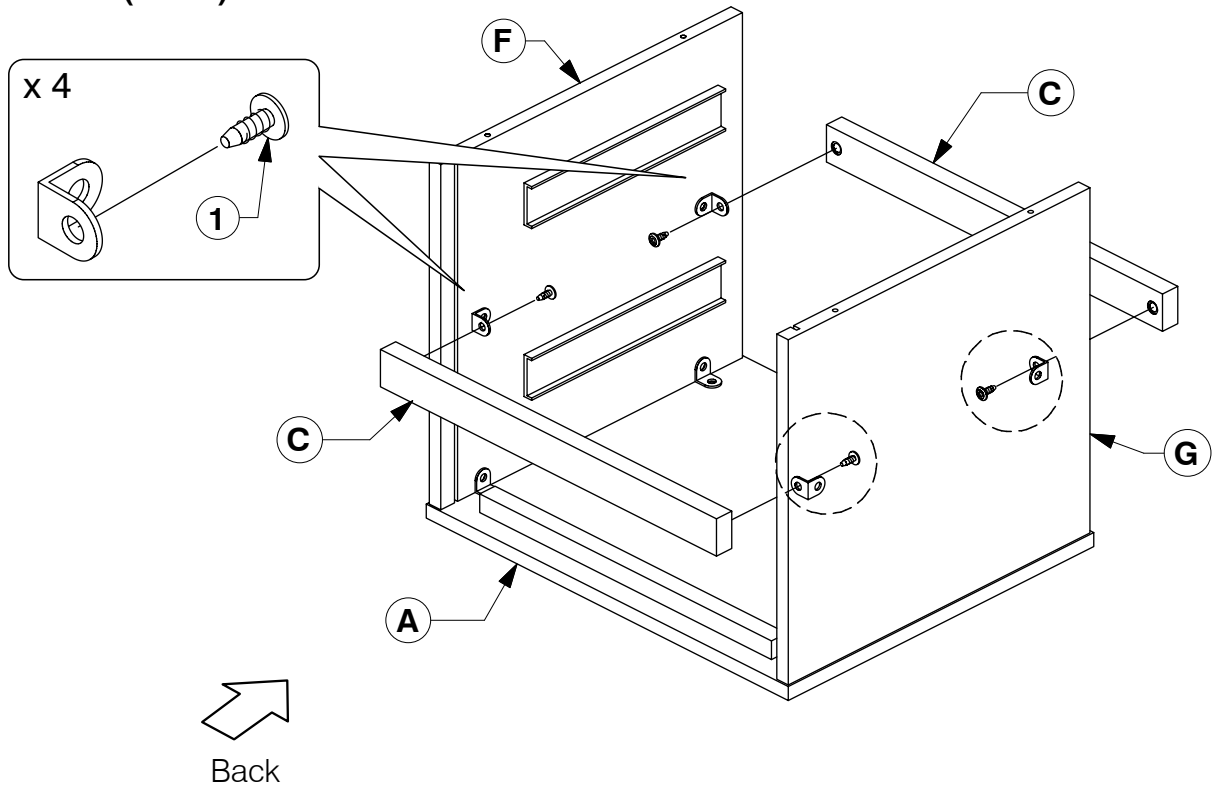

- 9** Slide the Back Panel (D) into the groove on the back of the Side Panel (F & G).

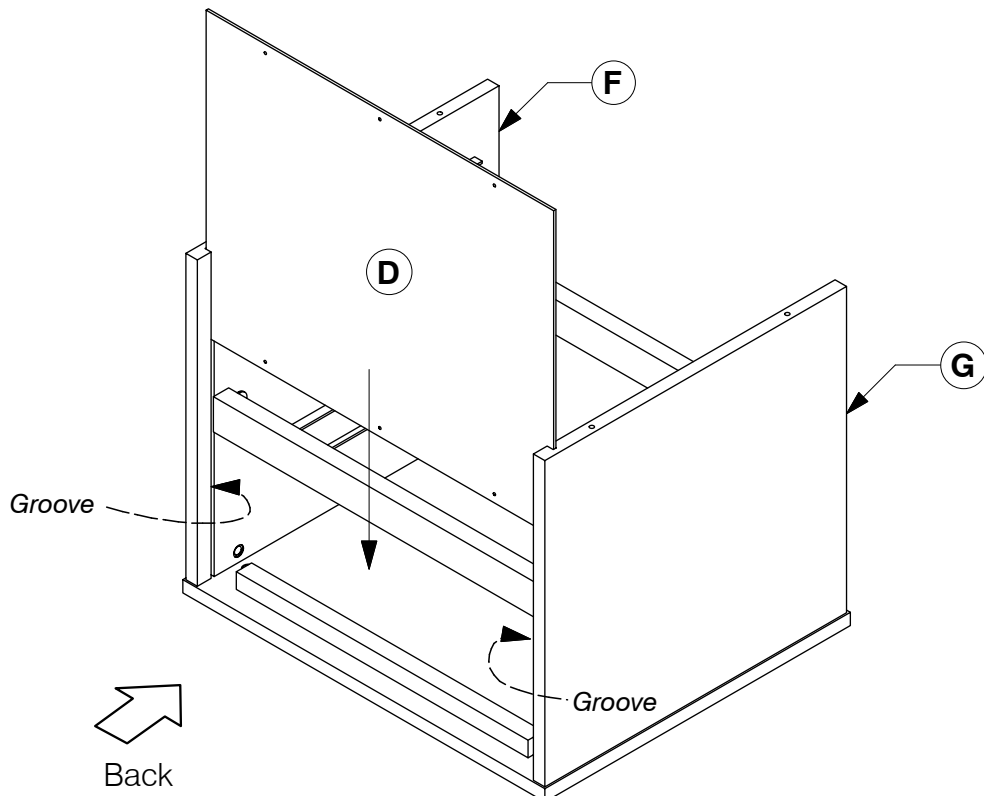

2 Drawer Nightstand

Assembly Instructions

- 10** Fit the Bottom Panel (B) to the Bottom of the Side Panel (F & G).

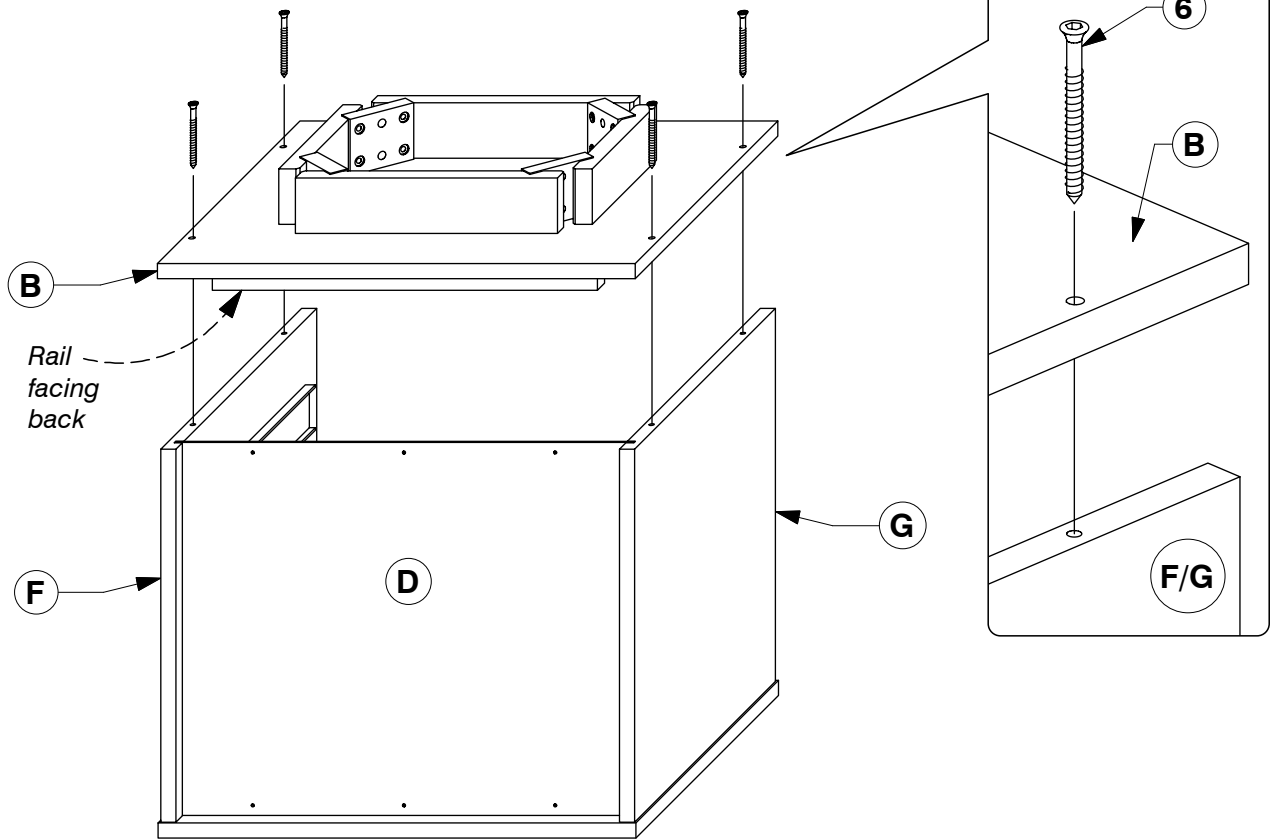

- 11** Use screws to tighten the Back Panel (D) to the back of the frame.

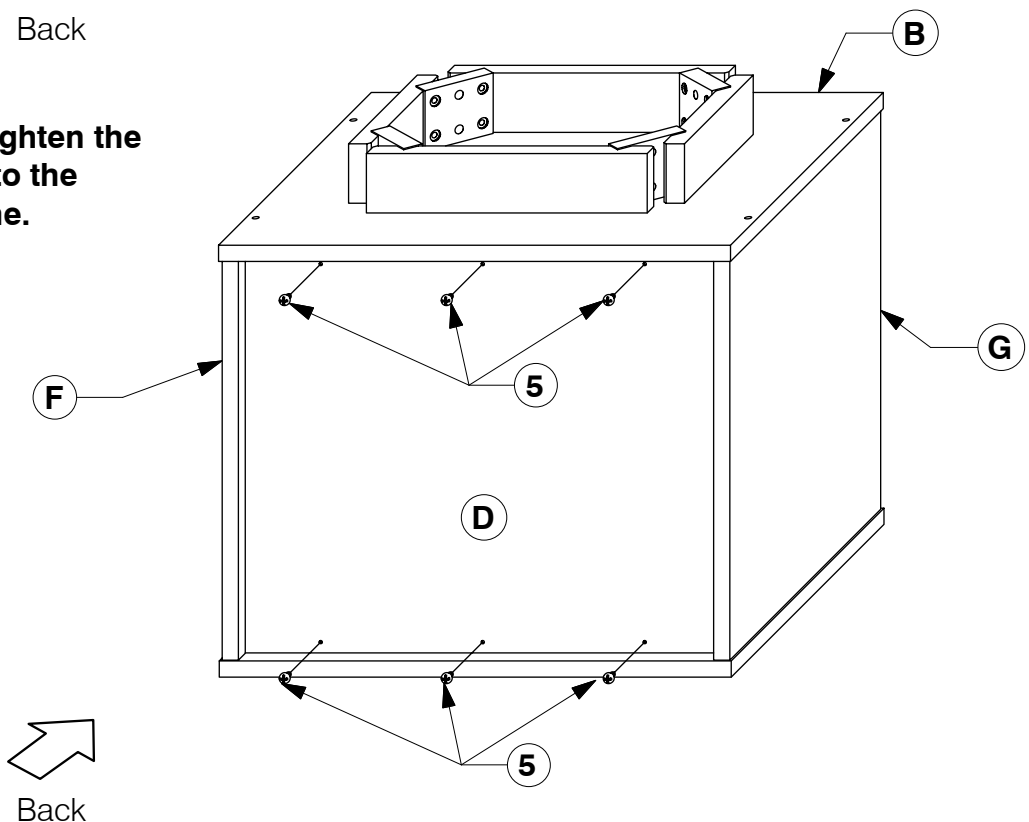

2 Drawer Nightstand

Assembly Instructions

12 Fit the Post (E) to the Bottom Panel (B).

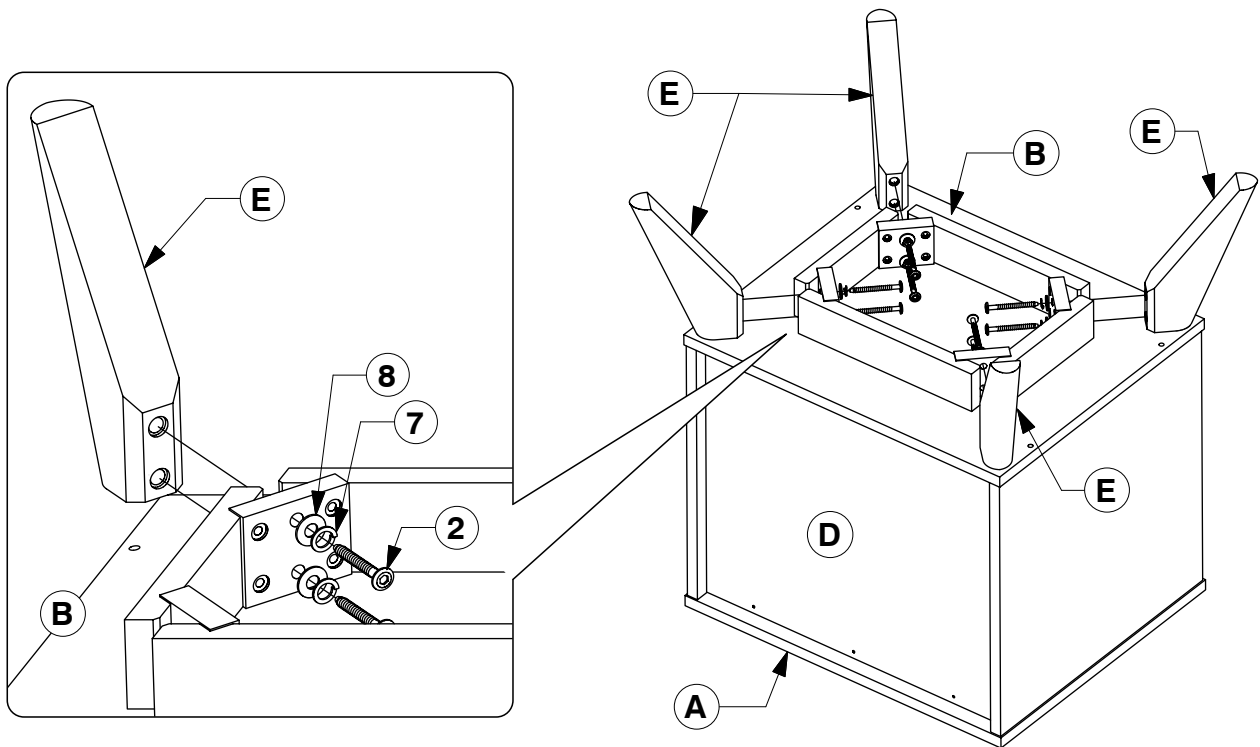

13 Fit and adjust the Drawer Face (H).

* NOTE: Before fitting the Wood Screws.
Loosen the JCBs on the Drawer Face if
the face needs alignment.

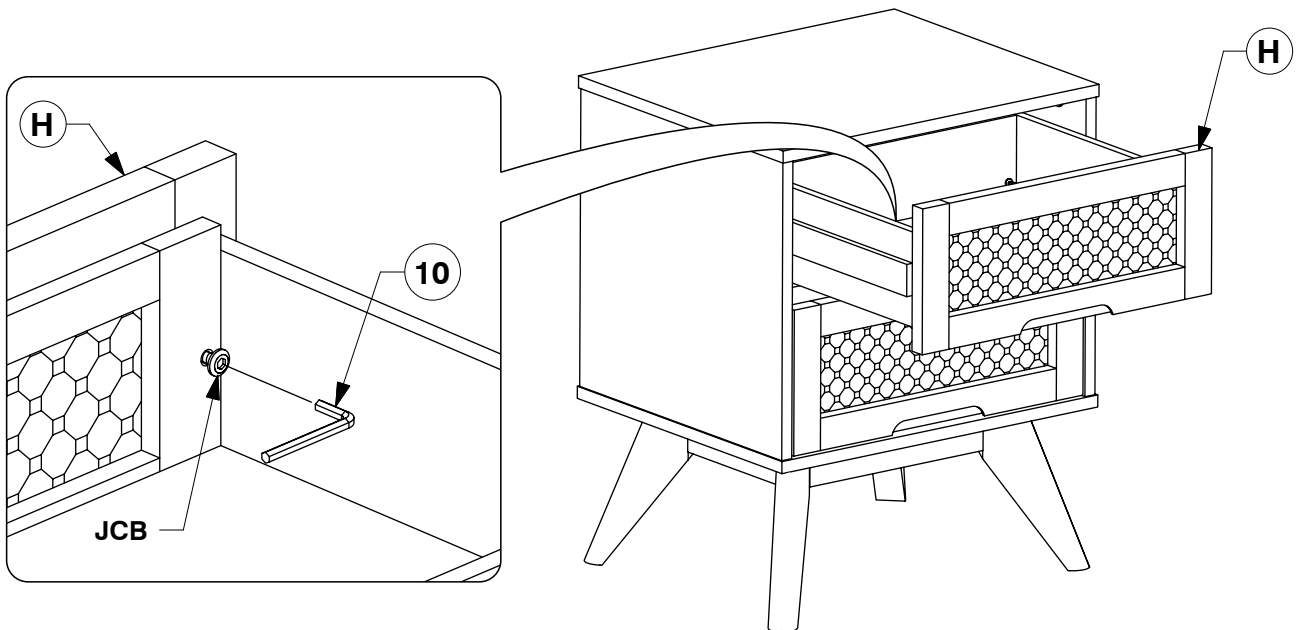

2 Drawer Nightstand

Assembly Instructions

14 After the Drawer Faces (H) are aligned, secure with wood screws.

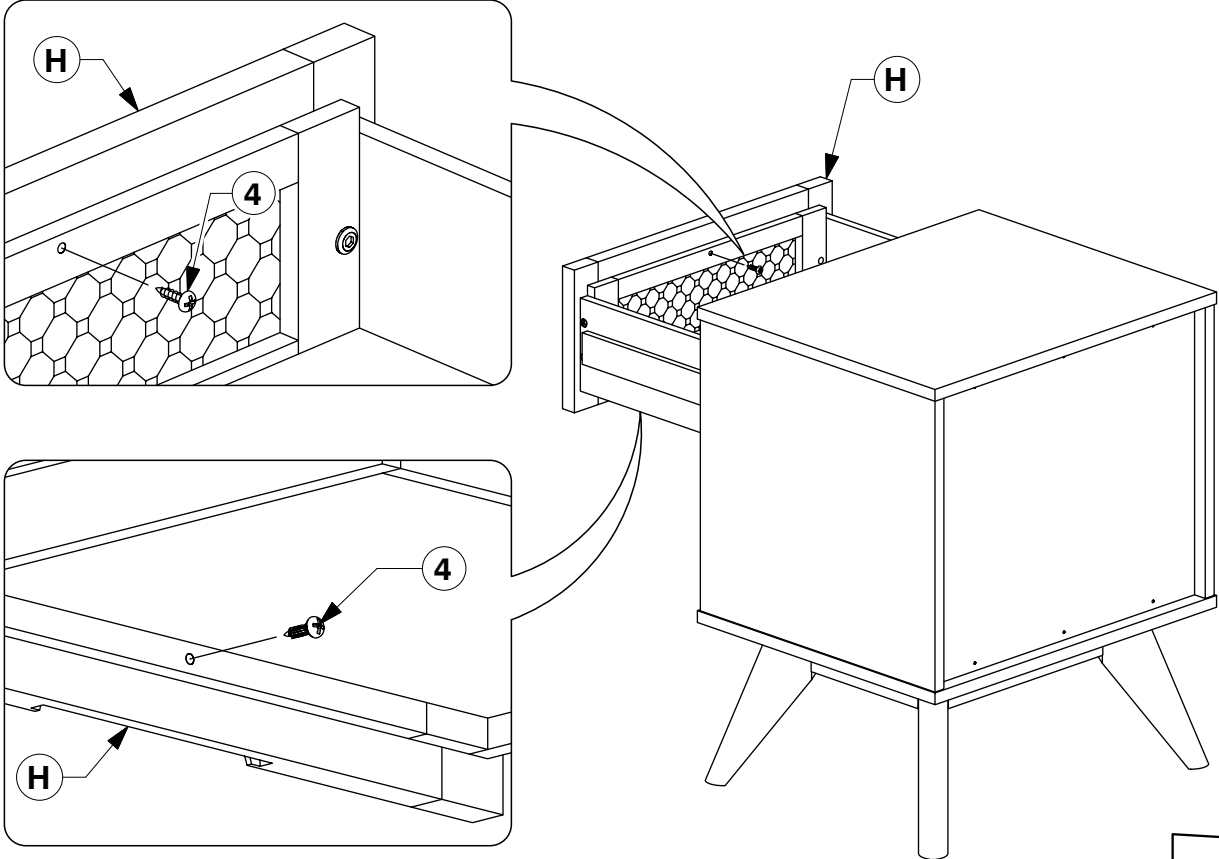

Back