

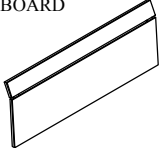

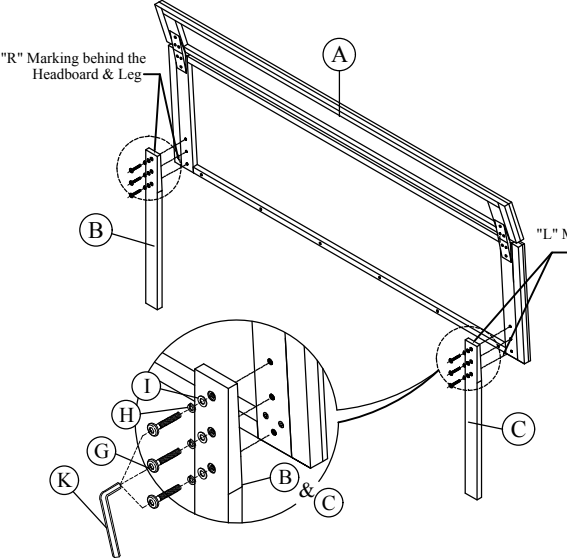

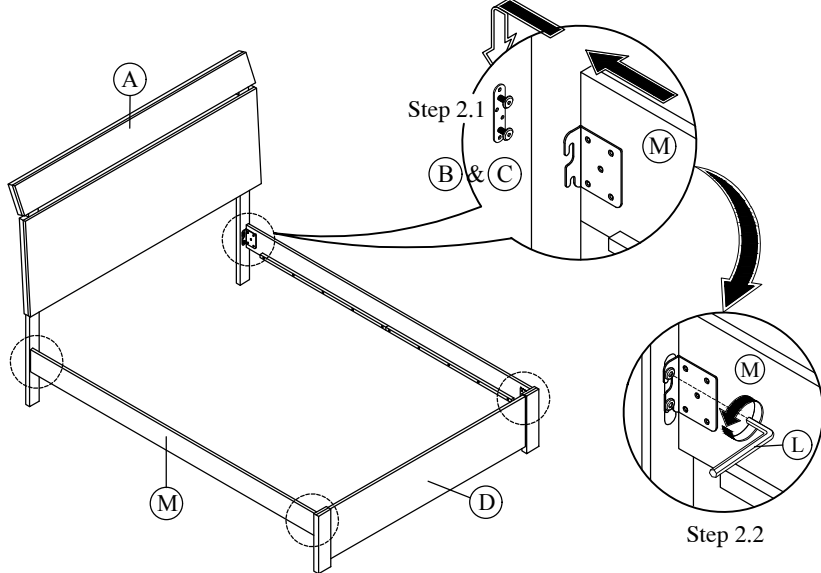

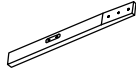

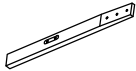
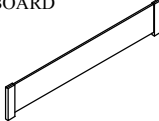
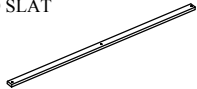
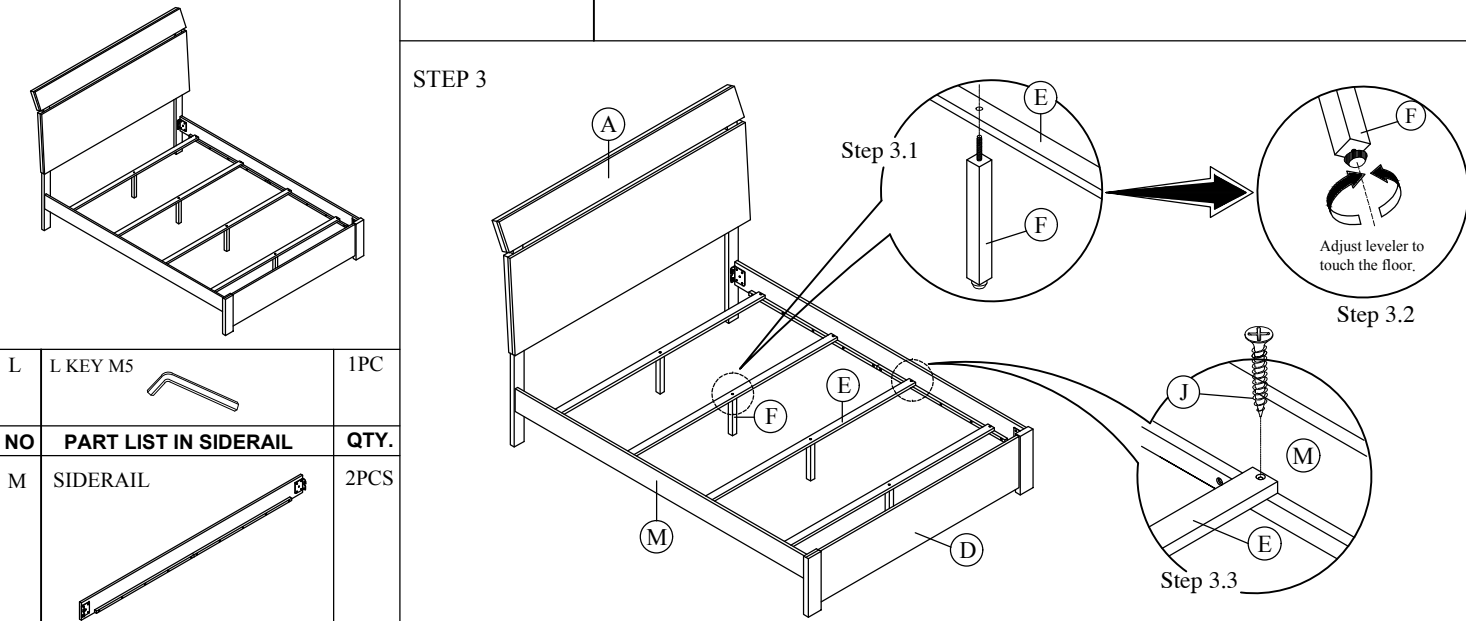

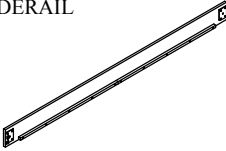

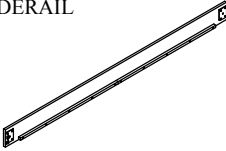
ASSEMBLY INSTRUCTION QUEEN SIZE BED

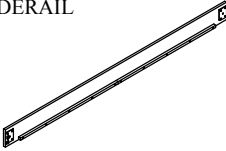
NO	PART & HARDWARE LIST IN HEADBOARD	QTY.	STEP 1	STEP 2									
A	HEADBOARD 	1PC	 <p>"R" Marking behind the Headboard & Leg</p> <p>"L" Marking behind the Headboard & Leg</p>	 <p>Step 2.1</p> <p>Step 2.2</p>									
B	HEADBOARD LEG RIGHT (R) 	1PC											
C	HEADBOARD LEG LEFT (L) 	1PC											
D	FOOTBOARD 	1PC											
E	BED SLAT 	4PCS	 <p>STEP 3</p> <p>Step 3.1</p> <p>Step 3.2 Adjust leveler to touch the floor.</p> <p>Step 3.3</p>	<table border="1" style="width: 100%; border-collapse: collapse;"> <tr> <td style="width: 5%;">L</td> <td style="width: 20%;">L KEY M5 </td> <td style="width: 5%;">1PC</td> </tr> <tr> <td style="width: 5%;">NO</td> <td style="width: 20%;">PART LIST IN SIDERAIL</td> <td style="width: 5%;">QTY.</td> </tr> <tr> <td style="width: 5%;">M</td> <td style="width: 20%;">SIDERAIL </td> <td style="width: 5%;">2PCS</td> </tr> </table>	L	L KEY M5 	1PC	NO	PART LIST IN SIDERAIL	QTY.	M	SIDERAIL 	2PCS
L	L KEY M5 	1PC											
NO	PART LIST IN SIDERAIL	QTY.											
M	SIDERAIL 	2PCS											
F	BED SLAT SUPPORT 	4PCS											
G	JCBC SCREW M6 x 35mm 	6PCS											
H	SPRING WASHER Ø1/4" 	6PCS											
I	FLAT WASHER Ø1/4" x 13mm 	6PCS											
J	CSK M4 x 32mm 	8PC											
K	L KEY M4 x 65mm 	1PC											