

# Owner Manual

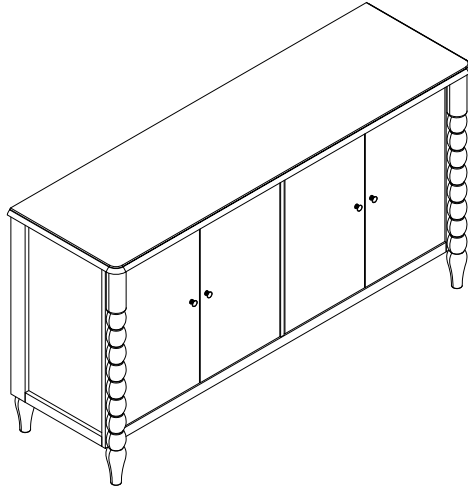

**150 LBS**

---

## **NOTE**





This brochure contains  
IMPORTANT safety info.  
Please read and keep it  
for future reference.

# MAINTENANCE AND WARNINGS



## Before You Start

### ***Please follow the steps below:***



-  Check the packaging for any damage, deformation, or water stains. If there is significant damage, please contact us promptly.
-  Open the packaging and confirm that the panels, hardware, screws, etc are complete.
-  Please read the installation instructions carefully to understand the installation steps and precautions to ensure proper installation.
-  Clean the installation area in advance and ensure the ground is level and there is enough space to avoid damaging the furniture or making installation difficult.
-  Lay a protective mat on the ground to prevent scratching the floor during installation.

### ***After-Sales Service***

- If you encounter any issues or need technical support during use, please contact our after-sales team. We offer long-term maintenance and warranty services.





## Precautions

-  This product for indoor use only. Do not expose it to outdoor elements or high-humidity environments.
-  Keep the product away from high heat or open flames to prevent fire hazards.
-  Do not allow children to climb on the product to prevent personal injury caused by tipping



## Safety Warnings

-  If you notice any loose or damaged parts, stop using the product immediately and contact customer service.
-  Do not attempt to disassemble or replace any components yourself, as this may affect the stability and safety of the product.

### ***Daily Maintenance***

- Regularly clean the surface of the sofa with a soft cloth to prevent dust accumulation.
- Do not use cleaning agents containing acids, alkalis, or corrosive substances, as they may damage the surface. It is recommended to use neutral cleaning agents or specialized furniture cleaners
- Avoid exposing furniture to humid environments for extended periods to prevent swelling or deformation of the boards. Use a dehumidifier or desiccant during humid weather.
- Avoid direct contact of furniture with water. If water is accidentally spilled, wipe it dry immediately.
- Avoid placing excessively heavy objects on the furniture: ensure the weight is within a reasonable load-bearing range.
- Avoid using sharp or rough items on the furniture surface to prevent scratches. Handle items gently when moving them

**Explosive view**

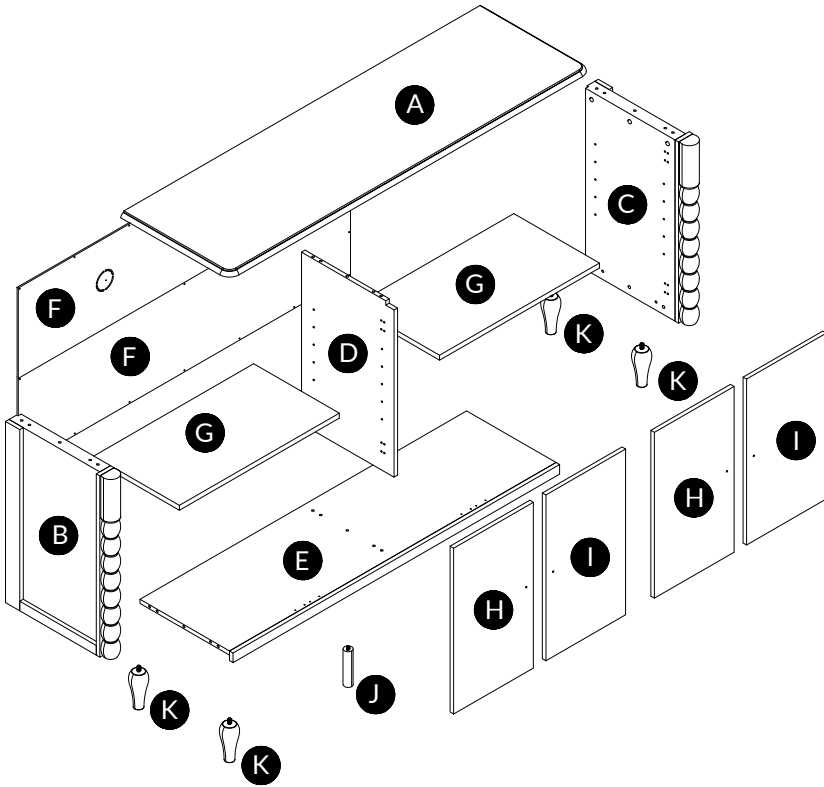

# Parts list

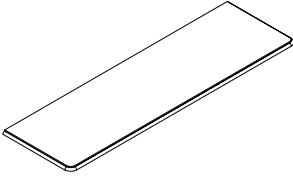
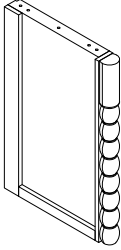
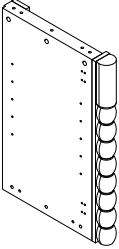
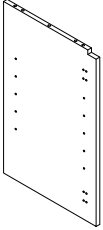
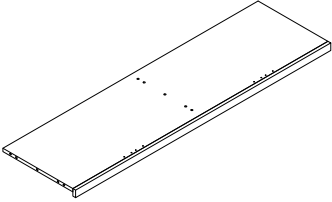
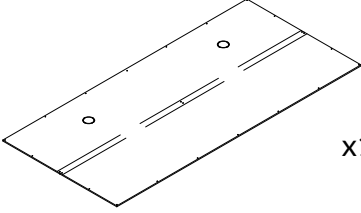
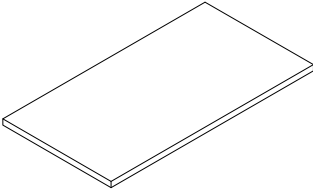
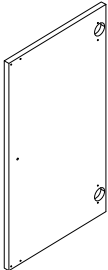
<p><b>A</b></p>  <p>x1</p>	<p><b>B</b></p>  <p>x1</p>
<p><b>C</b></p>  <p>x1</p>	<p><b>D</b></p>  <p>x1</p>
<p><b>E</b></p>  <p>x1</p>	<p><b>F</b></p>  <p>x1</p>
<p><b>G</b></p>  <p>x2</p>	<p><b>H</b></p>  <p>x2</p>



Installation:  
45minutes.



Two Person

## Parts list

I

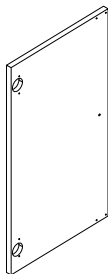

x2

J







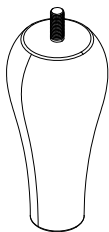

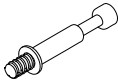

x1

K

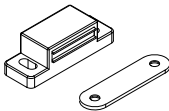

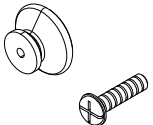



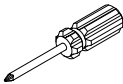
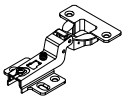

x4

# Hardware List

<p>1</p>  <p><b>x15+2</b></p>	<p>2</p>  <p><b>x15+2</b></p> <p>D15x12mm</p>	<p>3</p>  <p><b>x12+1</b></p> <p>D8x30mm</p>
<p>4</p>  <p><b>x8</b></p>	<p>5</p>  <p><b>x48+4</b></p> <p>D4x16mm</p>	<p>6</p>  <p><b>x3</b></p> <p>D7x40mm</p>
<p>7</p>  <p><b>x4</b></p> <p>D4x22mm</p>	<p>8</p>  <p><b>x8</b></p>	<p>9</p>  <p><b>x15</b></p>
<p>10</p>  <p><b>x20+2</b></p> <p>D3.5x14mm</p>	<p>11</p>  <p><b>x1</b></p>	<p>12</p>  <p><b>x8</b></p>

## Hardware List



<p>13</p>  <p>x1</p>	<p>14</p>  <p>x4</p>	<p>15</p>  <p>x4</p> <p>D4x30mm</p>
<p>16</p>  <p>x4</p>	<p>17</p>  <p>x2</p>	<p>18</p>  <p>x16+2</p> <p>D3x14mm</p>
<p>19</p>  <p>x24+2</p> <p>D3x16mm</p>		

## Step 1

Prepare for part A

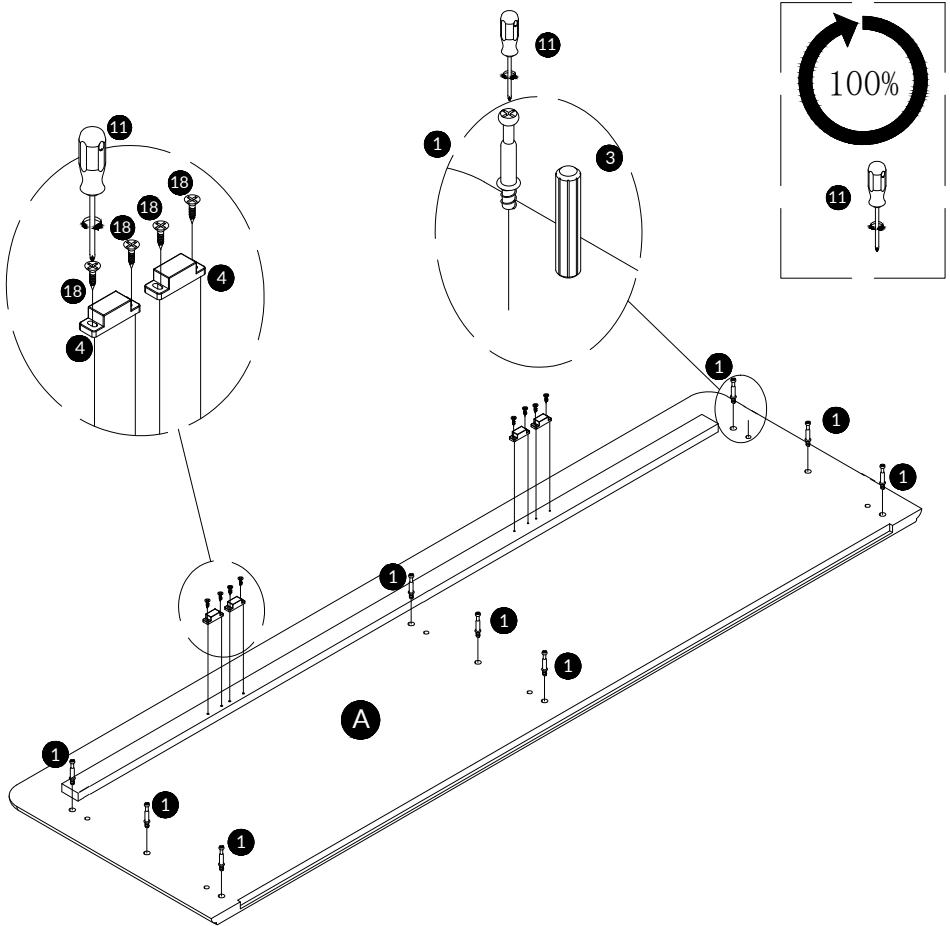
1. Tighten the bolt #1 into the corresponding hole of A with screwdriver #11
2. Use screws #18 to attach part # 4 with screwdriver # 11 as picture shown

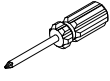
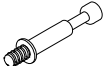

4	x4	18	x8	11	x1	1	x9
							
		D3x14mm				M6x35mm	

## Step 2

Tighten the bolt #1 into the corresponding hole of B&C with screwdriver #11

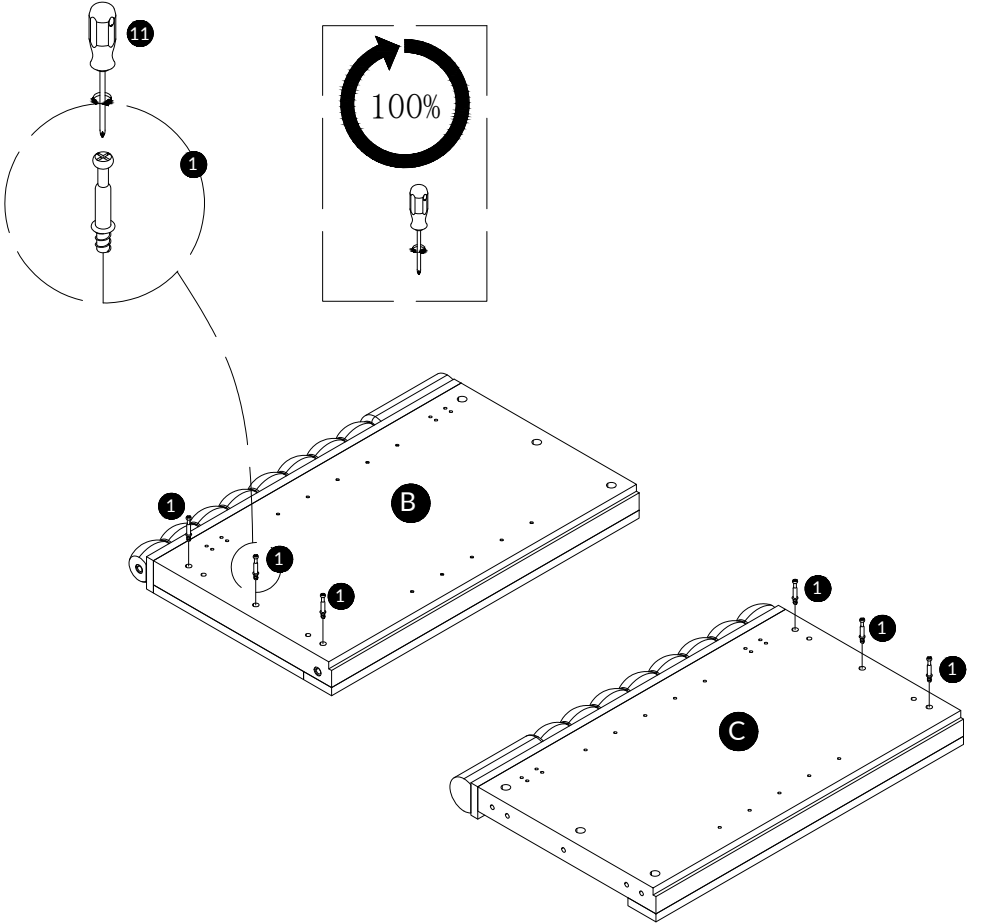

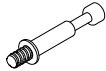
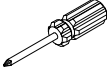

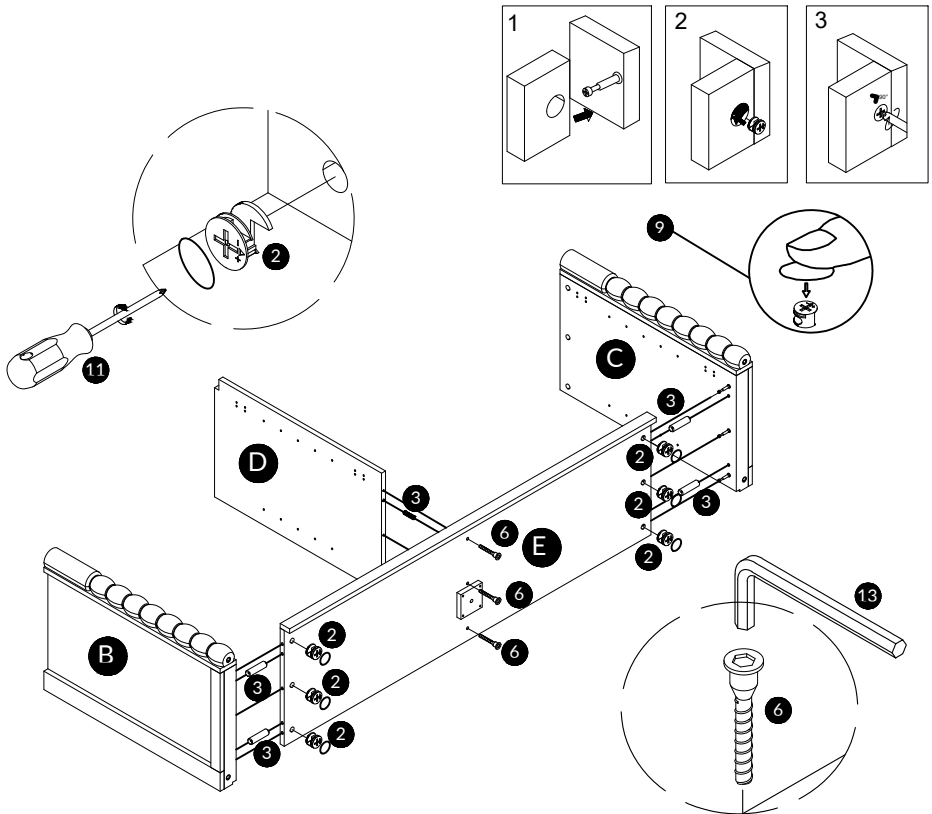

<b>1</b>	x6	<b>11</b>	x1
			
D6x35mm			

## Step 3

- 1.Align the holes in part E,insert wooden dowel #3 by hand
- 2.Connect the part B&C with part E,insert cam bolt #2 into the corresponding hole of panel E.then tighten the cam bolt #2 with screwdriver #11, cover the cam lock #2 with sticker #9
- 3.Use bolt #6 to connect part E&D with Allen key #13

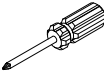

13	x1	6	x3	3	x6	2	x6	9	x6	11	x1
											
		D7x40mm		D8x30mm		D15x12mm					

## Step 4

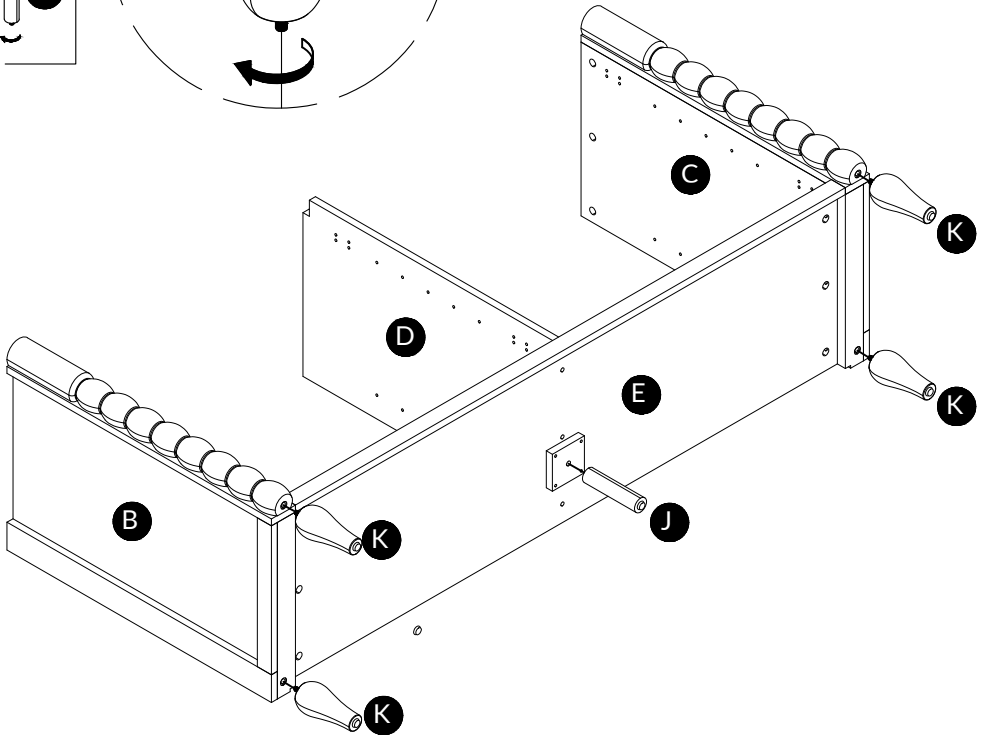
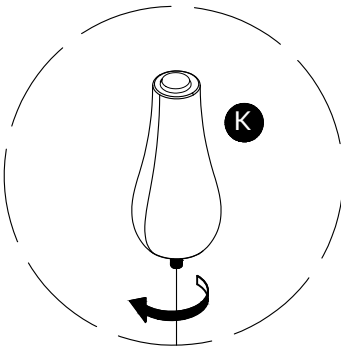
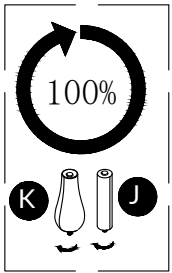

Screw foot L&J into part E by hand as picture shown

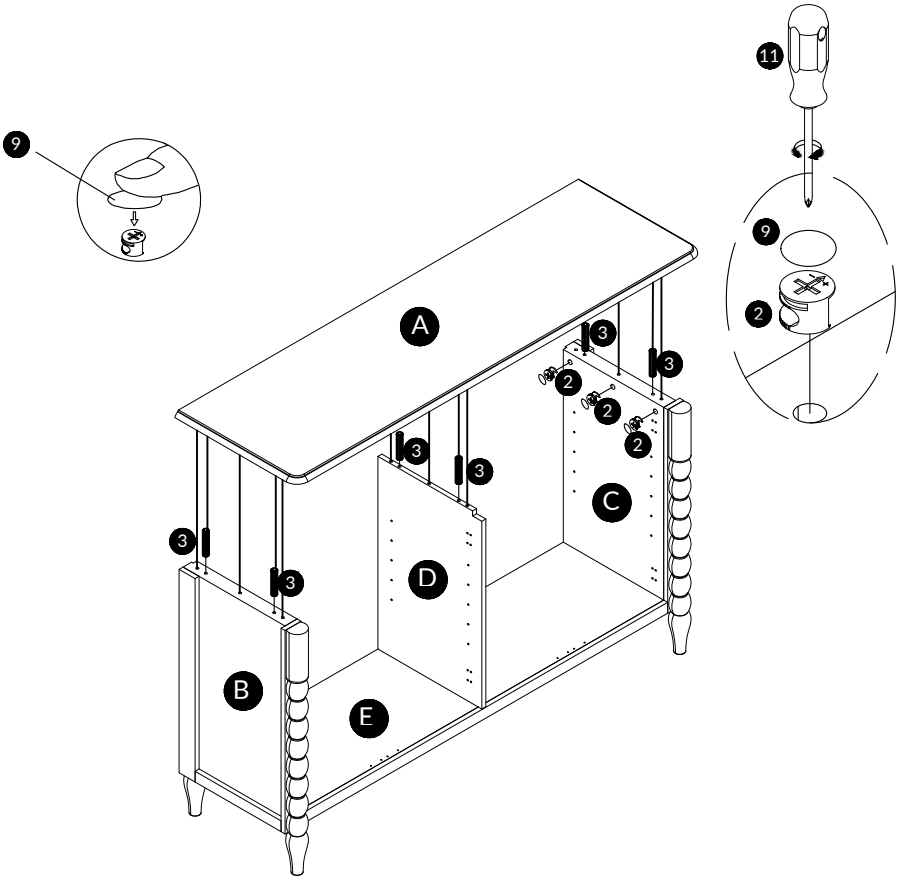

## Step 5

- 1.Align the holes in part B&D&C,insert wooden dowel #3 by hand
- 2.Connect the part B&C&D with part A,insert cam bolt #2 into the corresponding hole of part B&C&D,then tighten the cam bolt #2 with screwdriver #11, cover the cam lock #2 with sticker #9



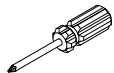

3	x6	2	x9	9	x9	11	x1
							
D8x30mm		D15x12mm					

## Step 6

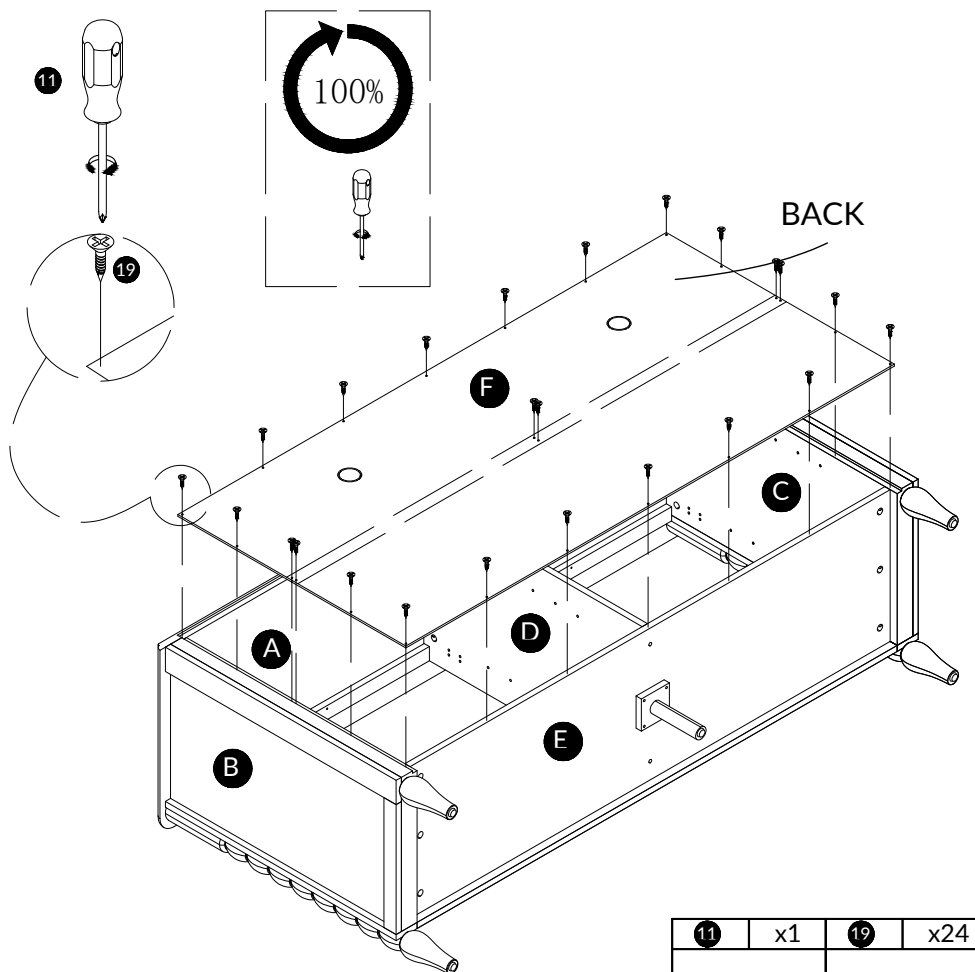
1. Lay down the cabinet on the level and make sure that the cabinet front facing downwards
2. Use screw #19 to attach part F with screwdriver #11 and tighten fully as picture shown
3. Please make sure that the panels which stick "BACK" are towards wall

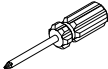



11	x1	19	x24
			
D3x16mm			

## Step 7

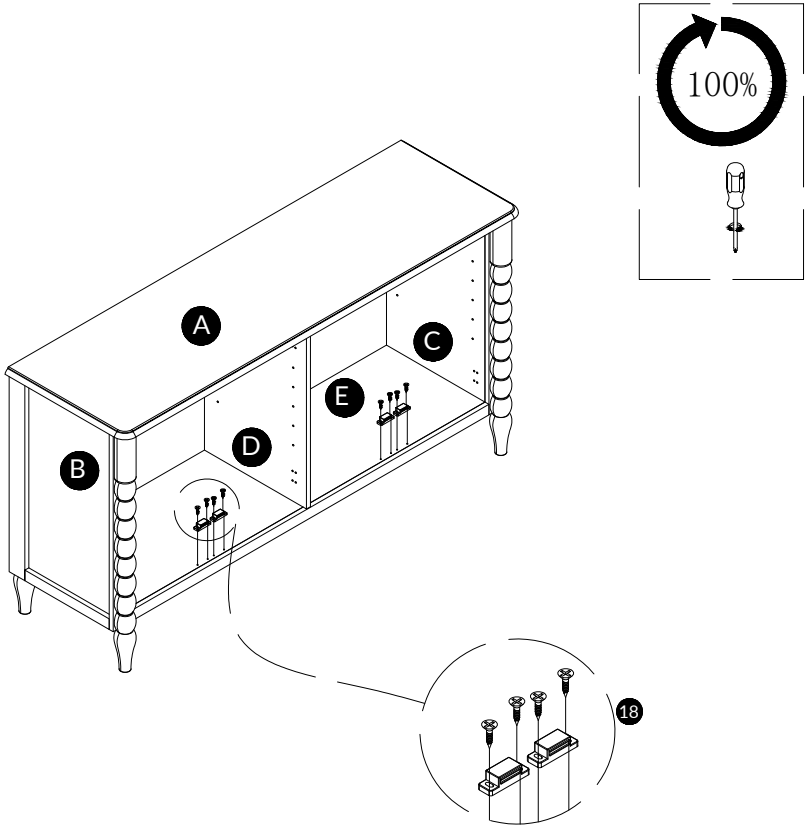
Use screws #18 to attach part # 4 with screwdriver # 11 as picture shown

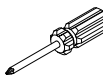

11	x1	4	x4	18	x8
					
				D3x14mm	

## Step 8

Insert shelf support #8 into the holes

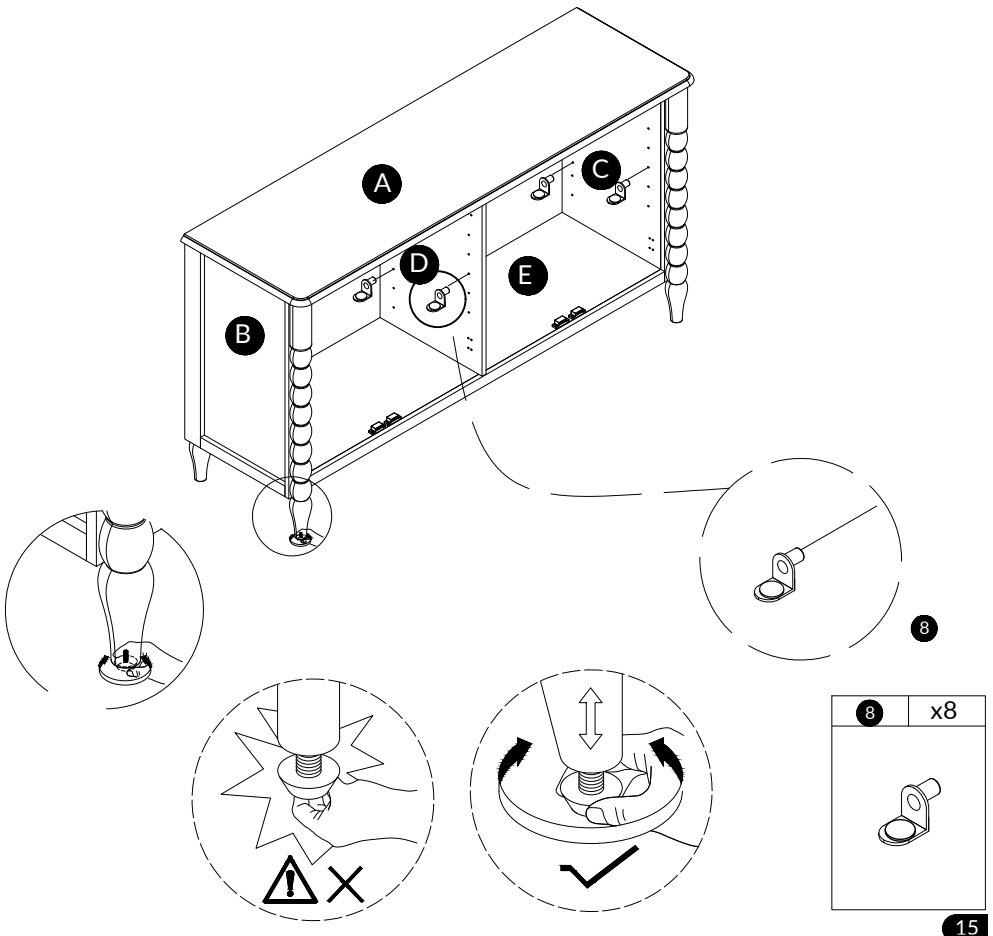

## Step 9

Attach adjustable shelf G to shelf support #8

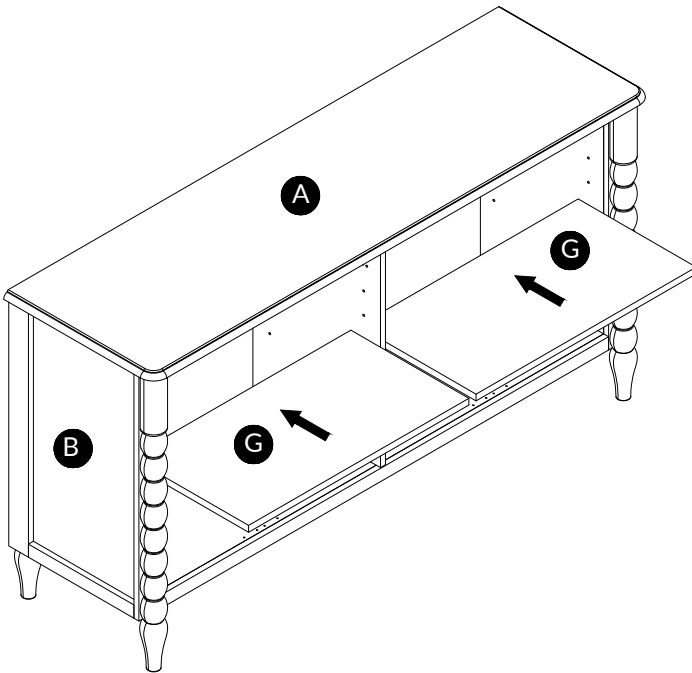

## Step 10

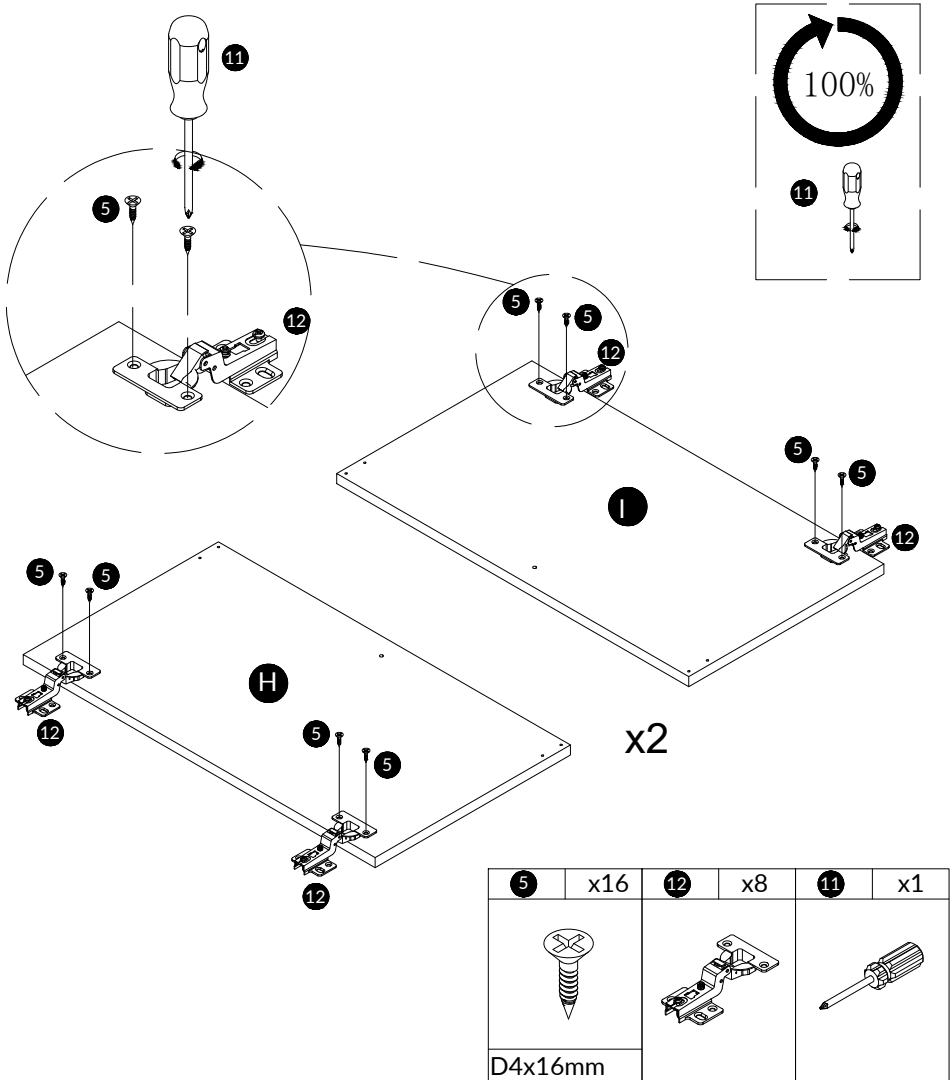

Use screw #5 to attach the hinges #12 to door panel (H&I), tighten screws #5 with screwdriver #11

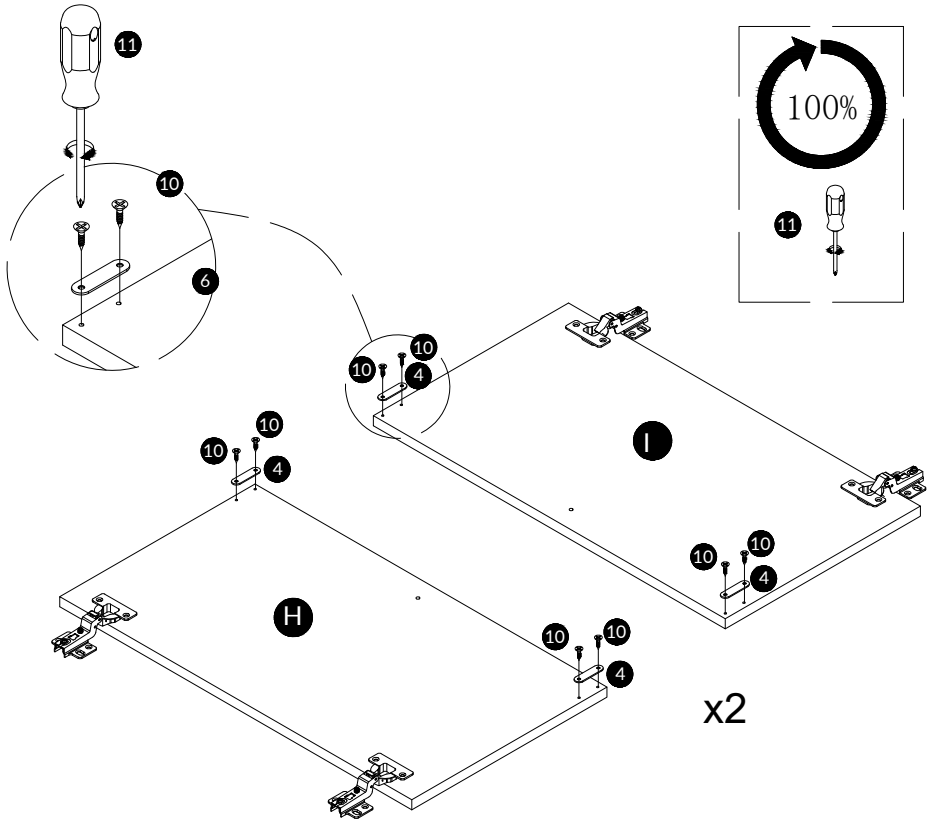

## Step 11

Use screw #10 to attach the hardware #4 to door panel (H&I), tighten screws #10 with screwdriver #11



10	x16	4	x8	11	x1
					
D3.5x14mm					

## Step 12

Use screw #7 to attach the handle #7 to door panel (H&I), tighten screws #7 with screwdriver #11.

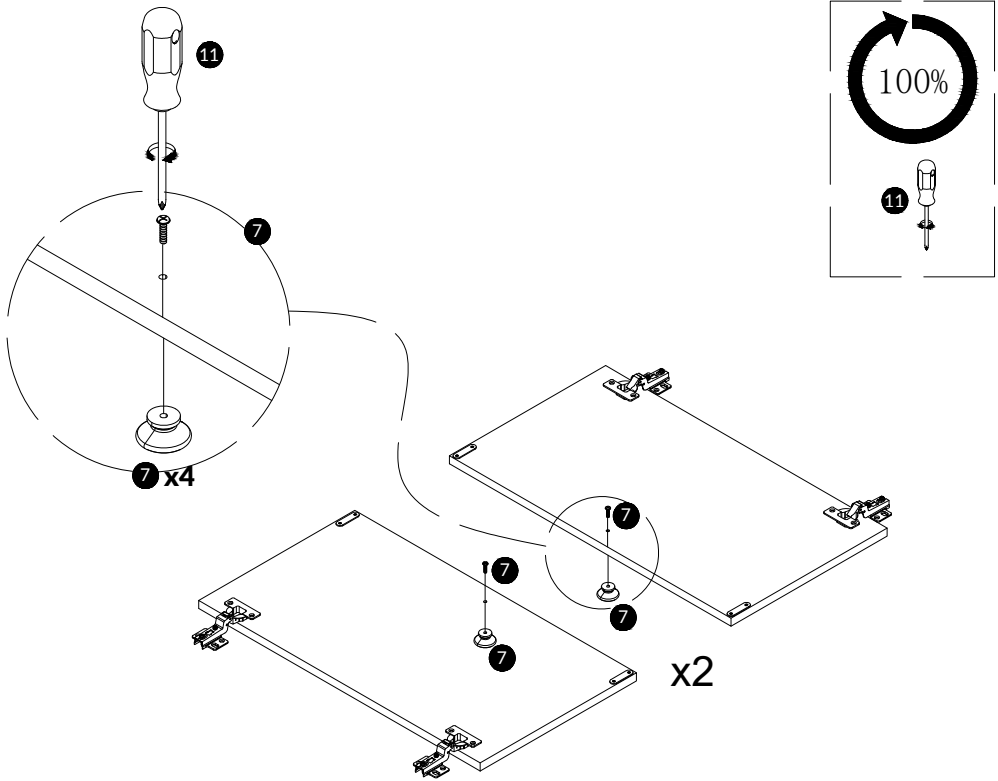

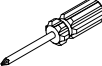
<b>7</b>	x4	<b>11</b>	x1
			
D4x22mm			

## Step 13

Use screw #5 to attach door panel I to part C and part D left side, Tighten screws #5 with screwdriver #19.

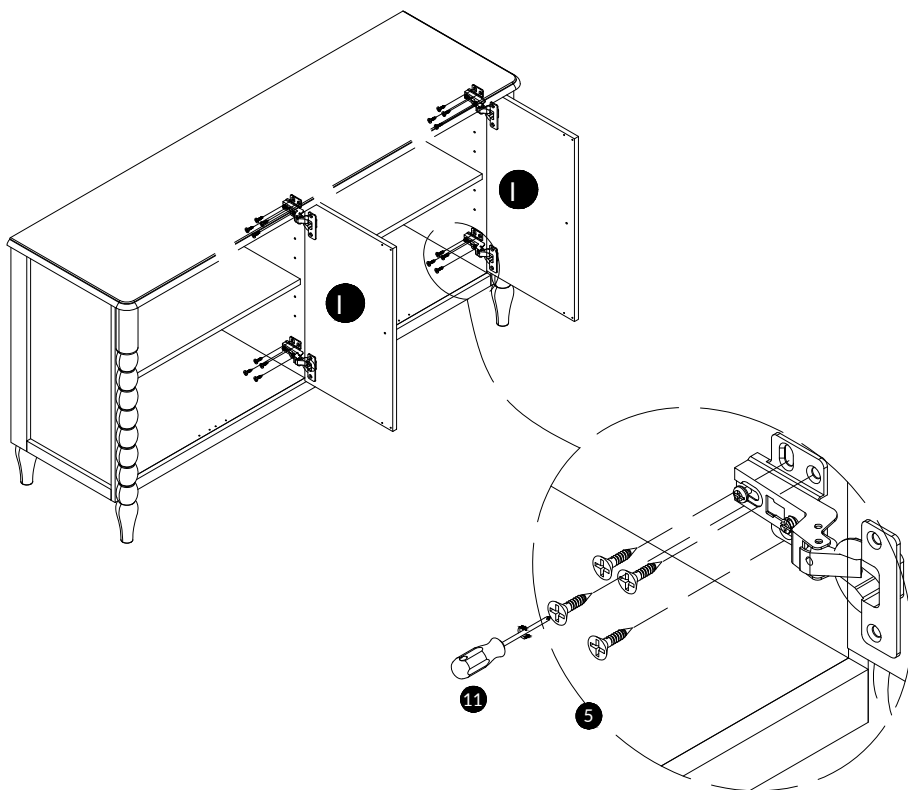

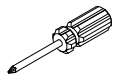
5	x16	11	x1
			
D4x16mm			

## Step 14

Use screw #5 to attach door panel H to part B and part D right side, Tighten screws #5 with screwdriver #19.

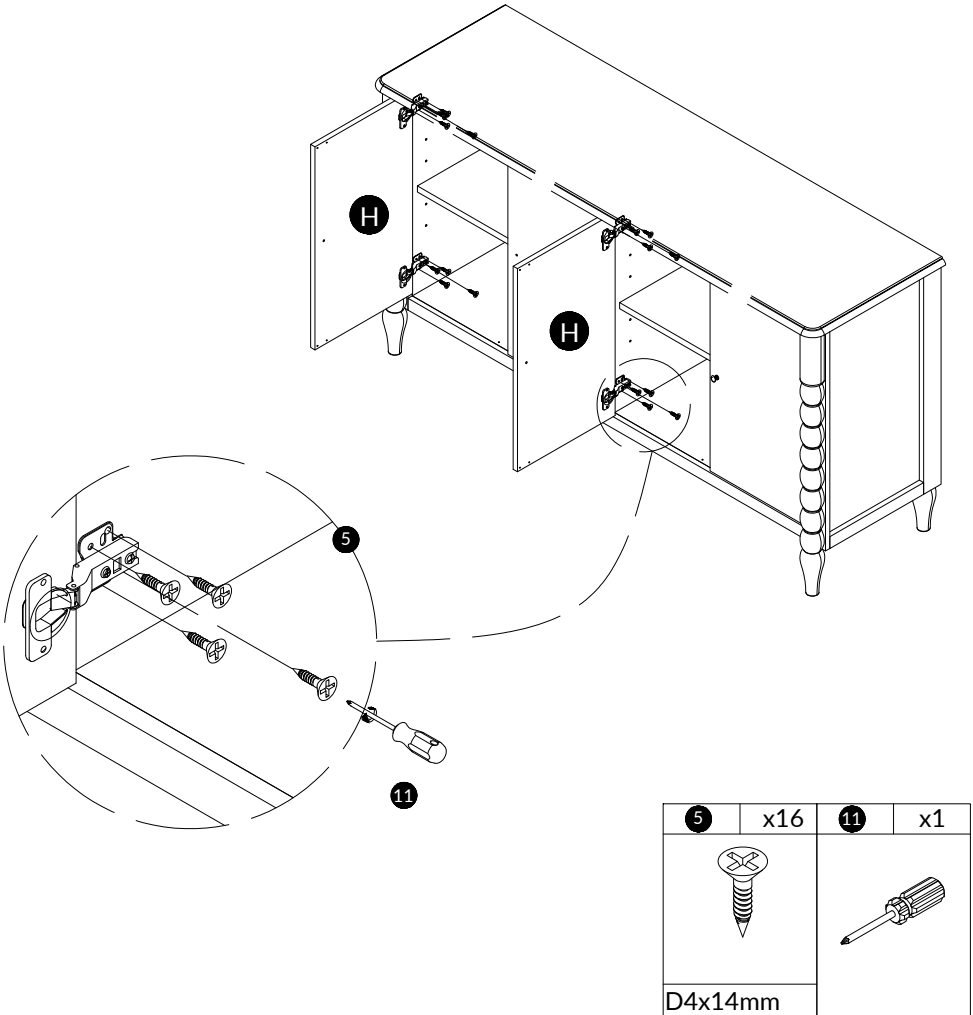

# Door Hinge Adjustment Instructions

Concealed hinges are three-way adjustable:

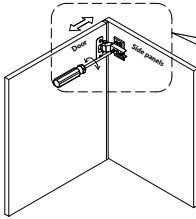

Horizontal  
by screw adjustment!

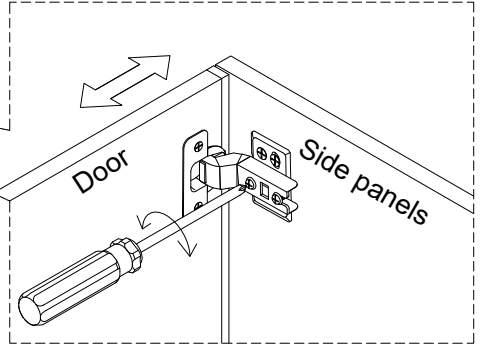

Concealed hinges are three-way adjustable:

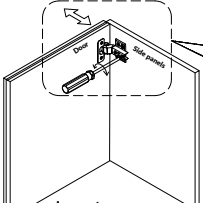

In and out  
by loosening the hinge arm  
mounting screw or via cam  
adjustment!

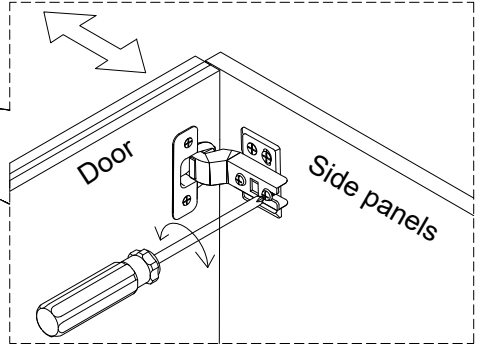

Concealed hinges are three-way adjustable:

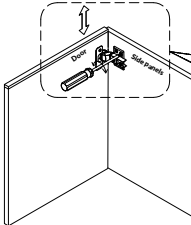

Vertical via slots in  
the mounting plate  
or via cam adjustment!

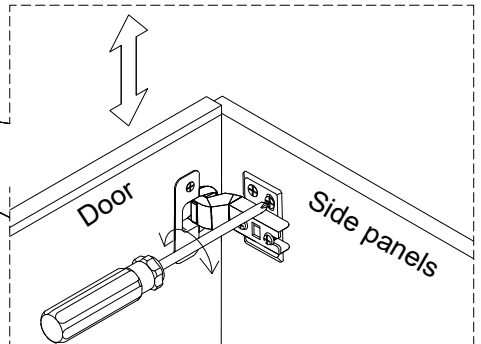



## Hinge adjustment method

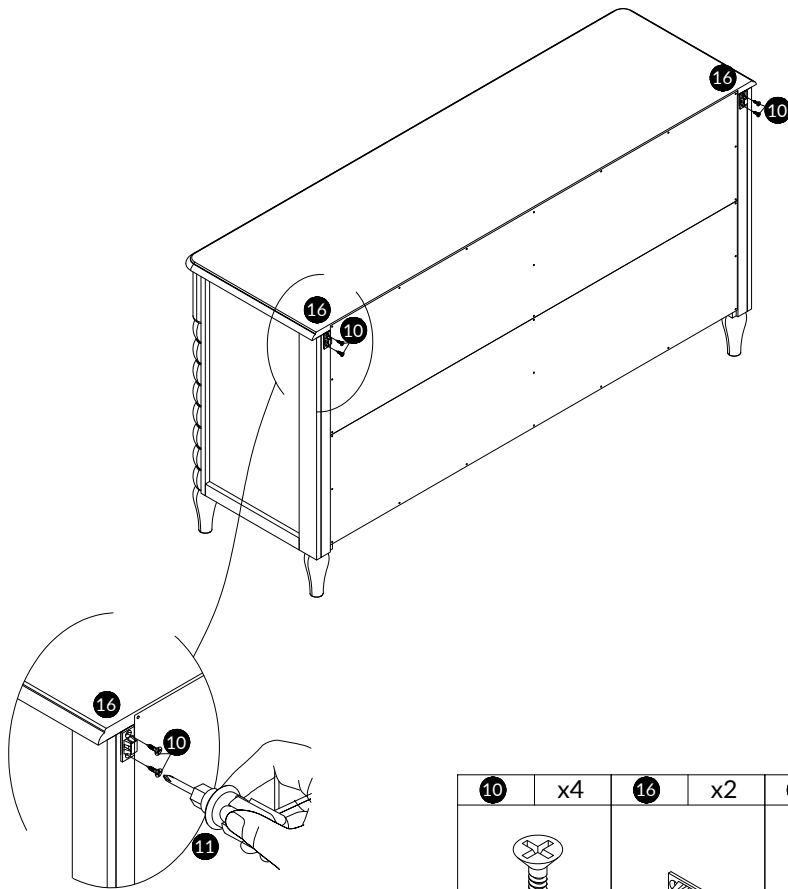

## Step 15

Use screws #10 to attach part #16 with screwdriver #11 as picture shown

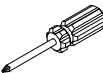

10	x4	16	x2	11	x1
					
D3.5x14mm					

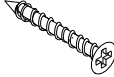
## Step 16

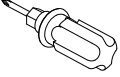
16	x2	15	x4	14	x4	11	x1
		 D4x30mm					

1. Install the anti-collapse device.
2. Mark the position on the wall, that corresponds to the location of part (#16) on the Side panel (B&C); Drill and insert the expandable screw (#14) by hammer.
3. Assemble the part (#16) to the wall. Align the hole in the part (#16) with the expandable screw (#14), use screw (#15) to attach it and tighten by screwdriver (#11)

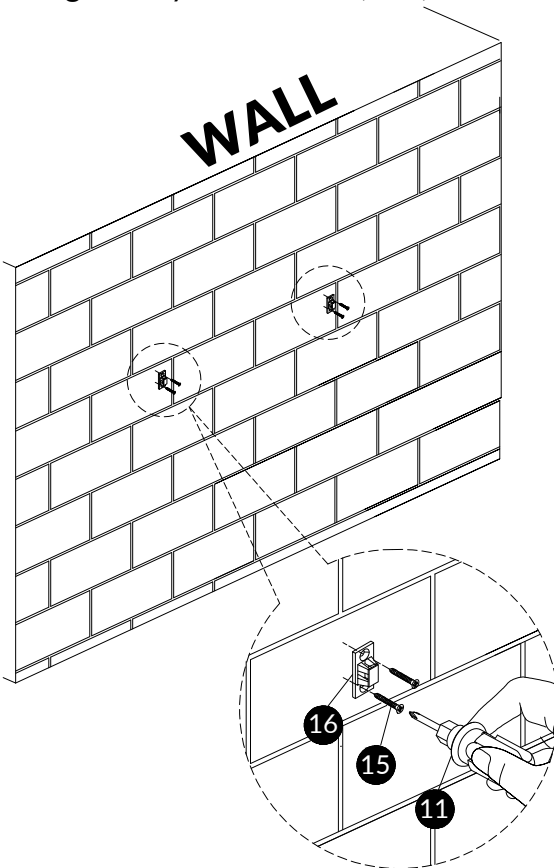

NOT PROVIDED

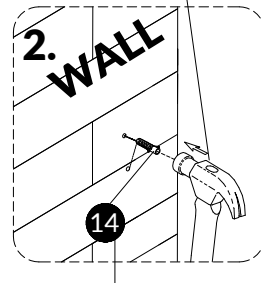
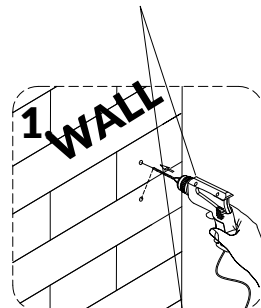

## Step 20

Let the plastic belt #17 pass through the both part #16 and pull tightly

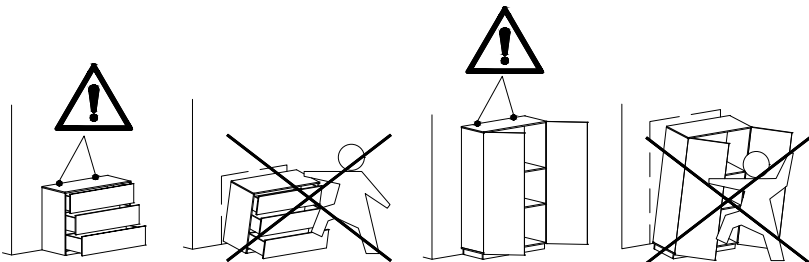
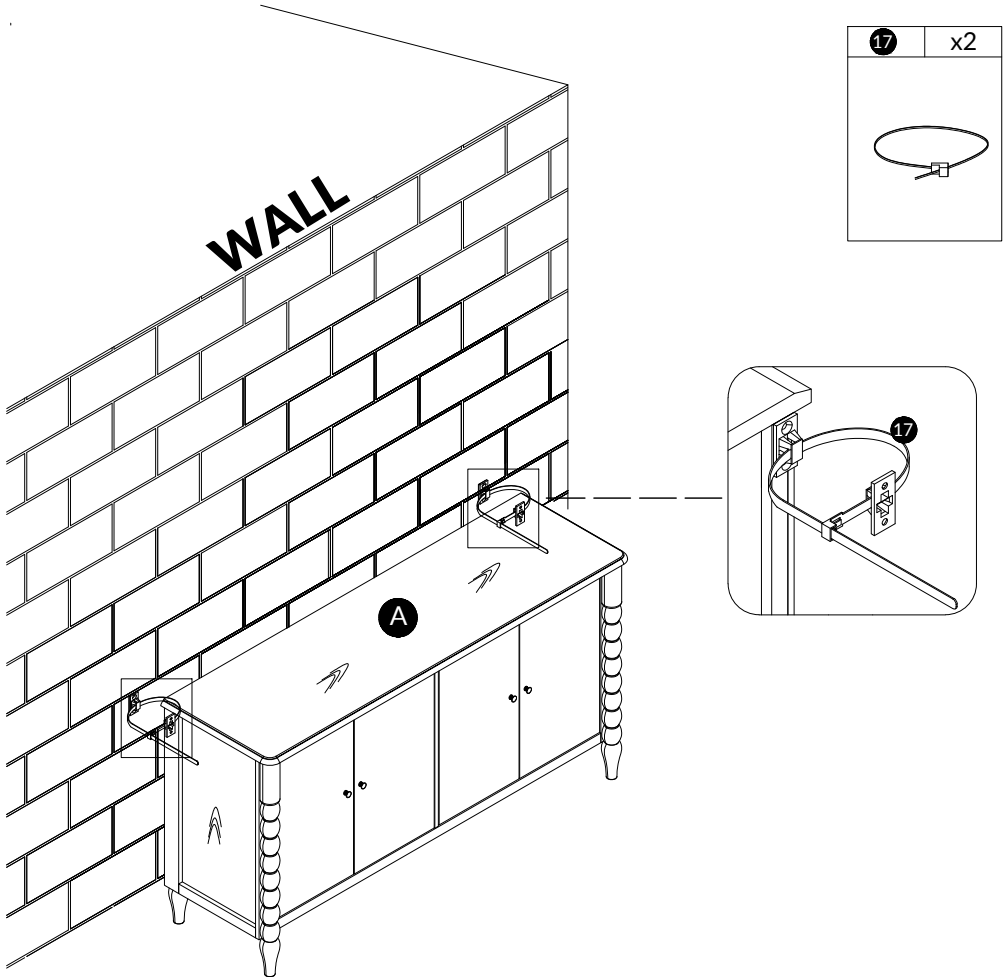

# WARRANTY

- We strive to offer quality products, and we also try our best to satisfy every customer who orders from us with products or services as needed.
- We provide 30 days warranty starting from the time you receive the item. Each customer must provide a record of their orders such as the order number, or item receipt for any items that are out of the warranty period you may also still receive.
- Replacement parts by purchasing them from our company if they are available.
- For return, please check the return policy with the retailer or market place you bought from