

Axis II Chair Instruction Sheet

Checklist of Included Items for Assembly:

- 1.) Frame: Seat Tray (1), Seat Back (1)
- 2.) Seat Base
- 3.) Back Cushion
- 4.) Slipcover (sold separately)
- 5.) Frame Clips (2)
- 6.) Screws (4)
- 7.) Washers (4)
- 8.) Philips Screw Driver (not included)

Step 1

Take the frame and line up the Seat Back with the Seat Tray on one side and affix 2 screws into the corresponding holes where they meet. Attach the screws on the other side the same way.

***Make sure screws are fully secured.**

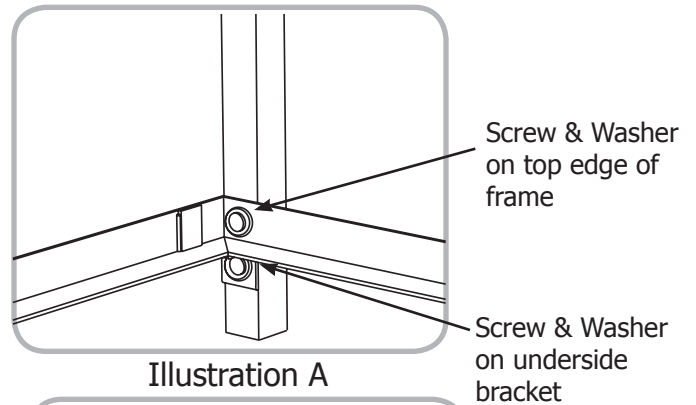

Step 2

The Axis II Collection is designed so you can place multiple units together to create a sectional to perfectly fit your space. Place 2 frames next to each other and place one clip in each corner to secure the two frames together. The clip will be held in place by the clip tab. See Illustration B.

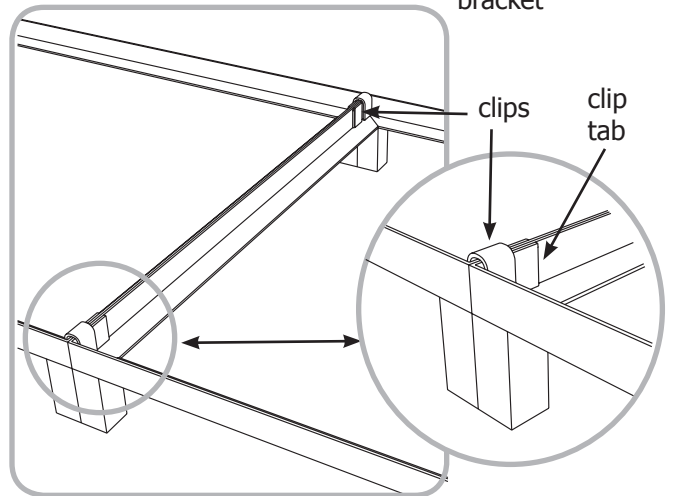

Step 3

Unfold the large slipcover. This is for the base. Lay it open side up on a clean surface. Take the Seat Base and flip it over so the bottom is on top and place it in the slipcover. Line up the corners and pull the slipcover up on all four sides. Once it is in place, take the excess fabric of the cover and fold it over the lip of the Base and attach it to the Velcro®. See Illustration C.



Illustration C

Step 4

Once the cover is secure, flip the Base over and place it in the frame making sure it fits snugly in the Seat Tray on all four sides. Insert the Back Cushion into its slipcover and place it on the Axis II Chair to complete your piece.



Axis II Chair Instruction Sheet

Step 5

The Axis II Cushion Slipcover features Velcro® straps that hold the back cushion in place. Affix the straps to the top bar of the seat back.



Note

The faux leather Slipcovers feature a fabric panel on the bottom of the Back Cushions to allow air to escape providing an even more comfortable Chair.

