

# ASSEMBLY INSTRUCTIONS

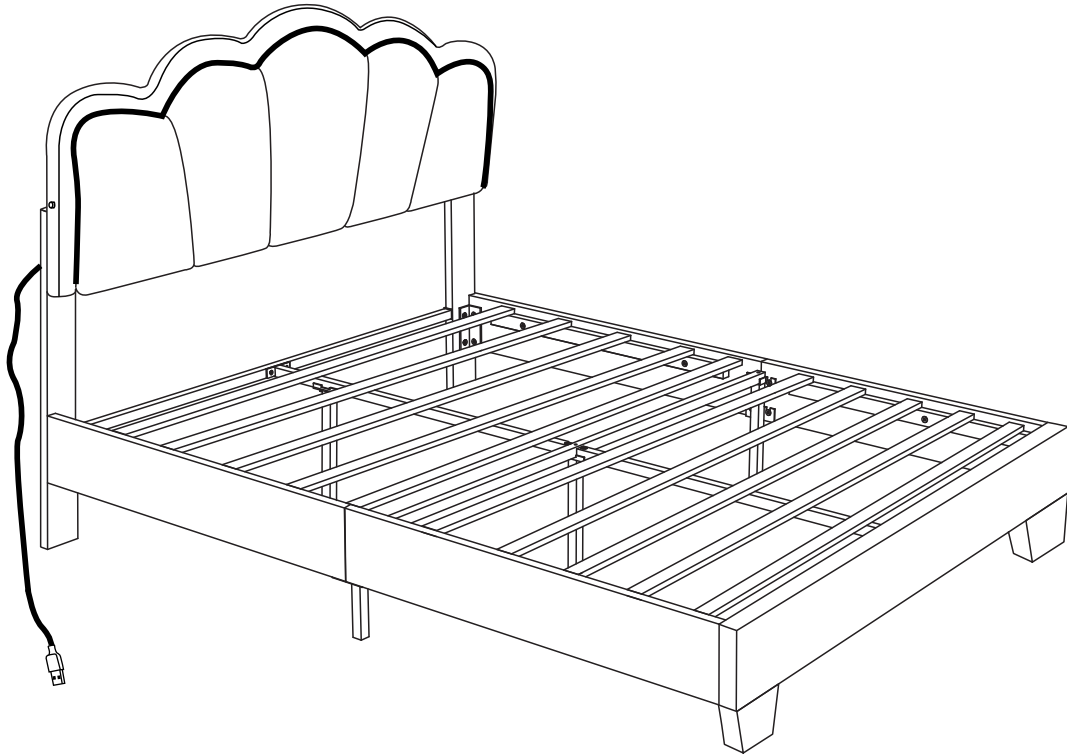

## IMPORTANT NOTE





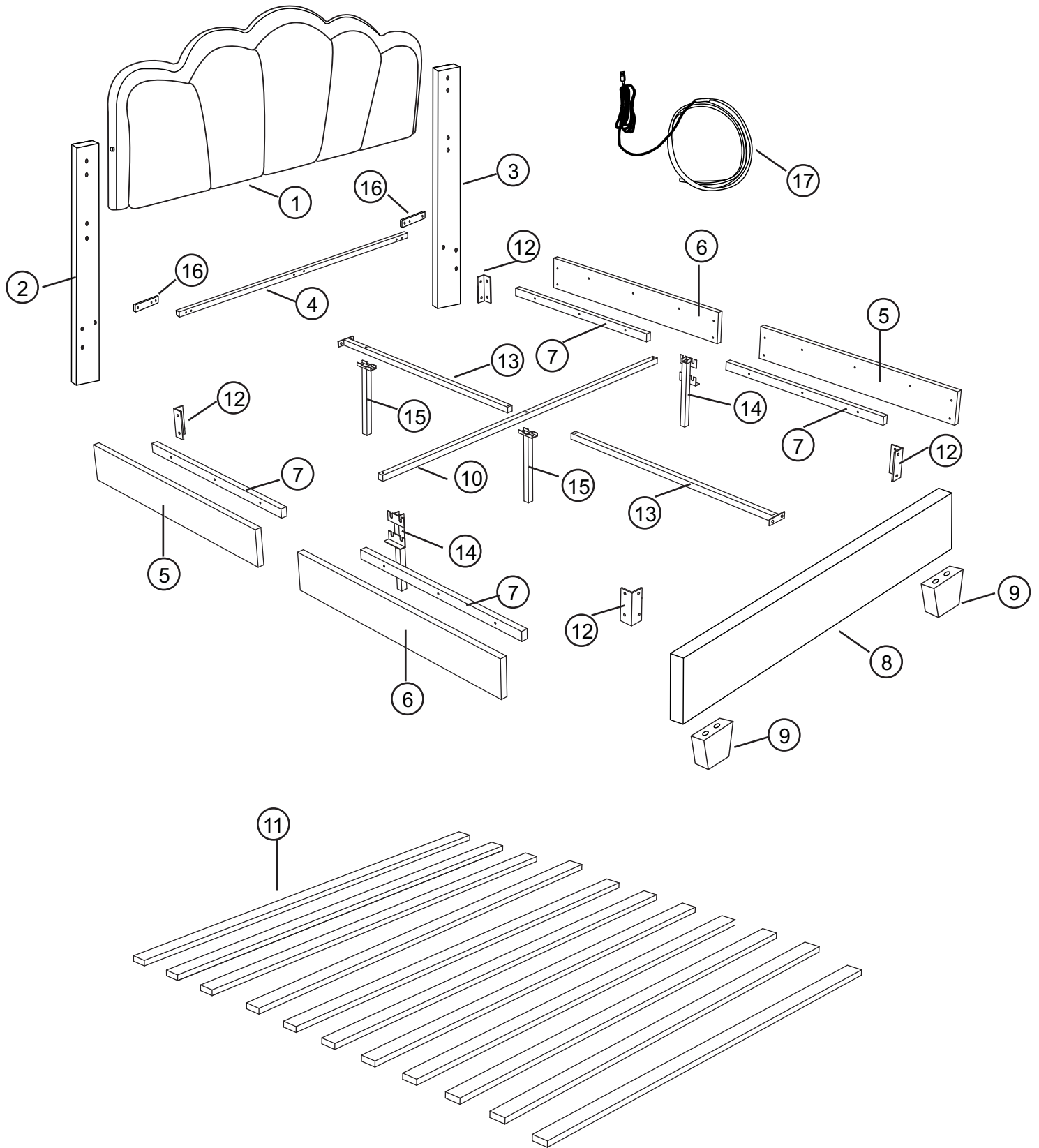



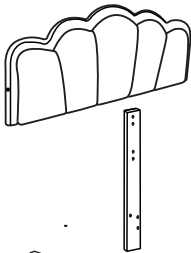

- \*\*PLACE ALL PARTS ON A CLEAN AND SMOOTH SURFACE SUCH AS A RUG OR CARPET TO AVOID THE PARTS FROM BEING SCRATCHED
- \*\*BEFORE YOU BEGIN, KINDY FOLLOW THE ASSEMBLY INSTRUCTIONS STEP BY STEP
- \*\*DO NOT TIGHTEN ALL SCREWS AND BOLTS UNTIL THE BED IS FULLY SET-UP

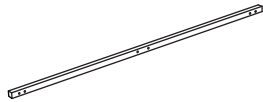
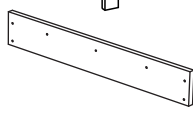
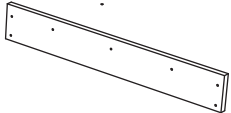
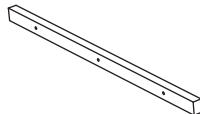
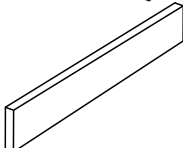
# ASSEMBLY INSTRUCTIONS

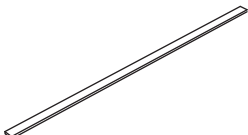
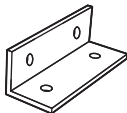



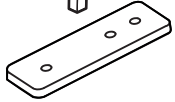

# ASSEMBLY INSTRUCTIONS

## PARTS IDENTIFICATION

1	Headboard		1pc	2	Post		1pc
3	Post		1pc	4	Support Bar		1pc
5	Side Panel		2pcs	6	Side Panel		2pcs
7	Bed side plate		4pcs	8	Footboard		1pc
9	Leg		2pcs	10	Center Rail		1pc
11	SLAT		10pcs	12	Bracket		4pcs
13	Center rail		2pcs	14	Support Leg		2pcs
15	Support Leg		2pcs	16	Bracket		2pcs
17	Light Strip		1pc				

## HARDWARE IDENTIFICATION

### HARDWARES IN

A	Bolt (Ø 6X70mm)		4pcs	B	Bolt (Ø 8X40mm)		22pcs
C	Bolt (Ø8X20mm)		34pcs	D	Allen Wrench (M4x75mm x32mm)		1pc

# ASSEMBLY INSTRUCTIONS

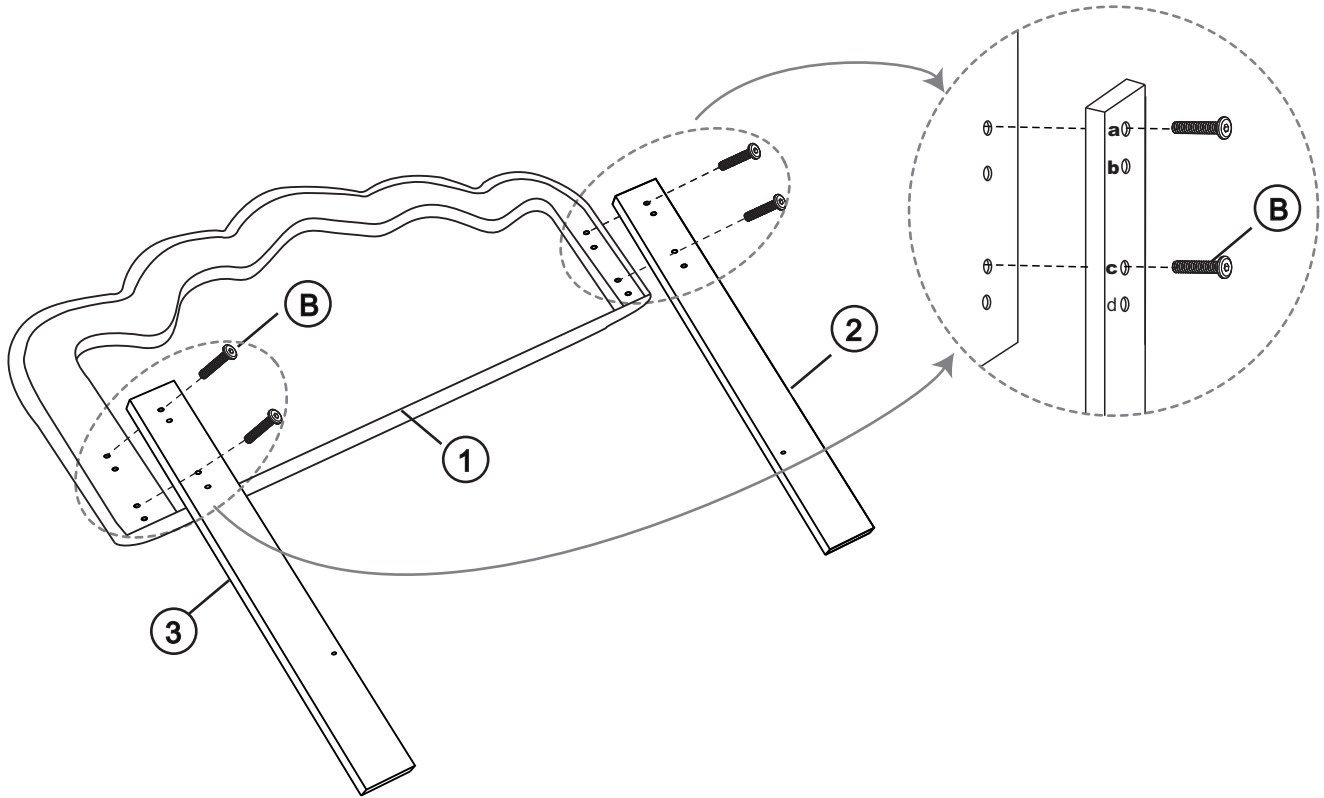

## STEP 1

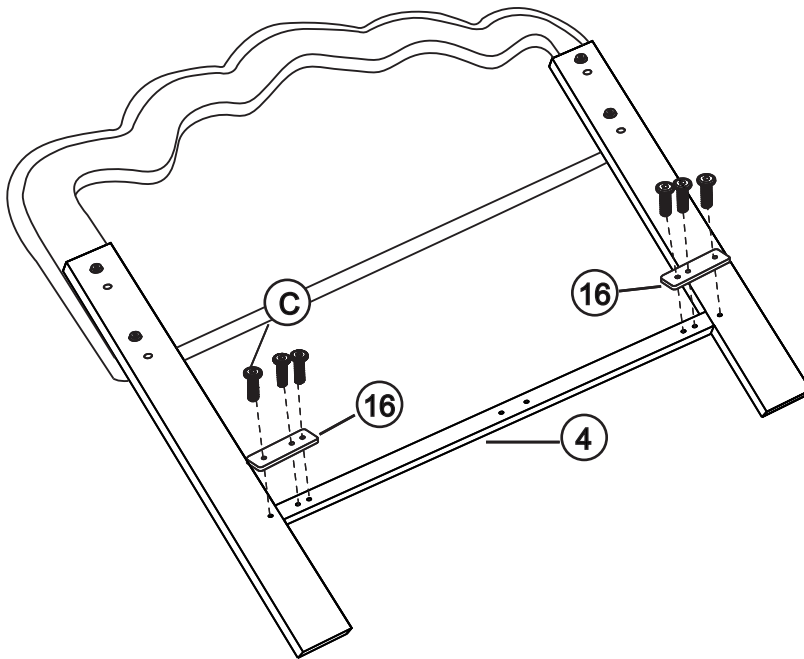

B	Bolt (Ø 8X40mm)		4
---	--------------------	---	---

## STEP 2



16	Bracket		2
C	Bolt (Ø 8X20mm)		6

# ASSEMBLY INSTRUCTIONS

## STEP 3

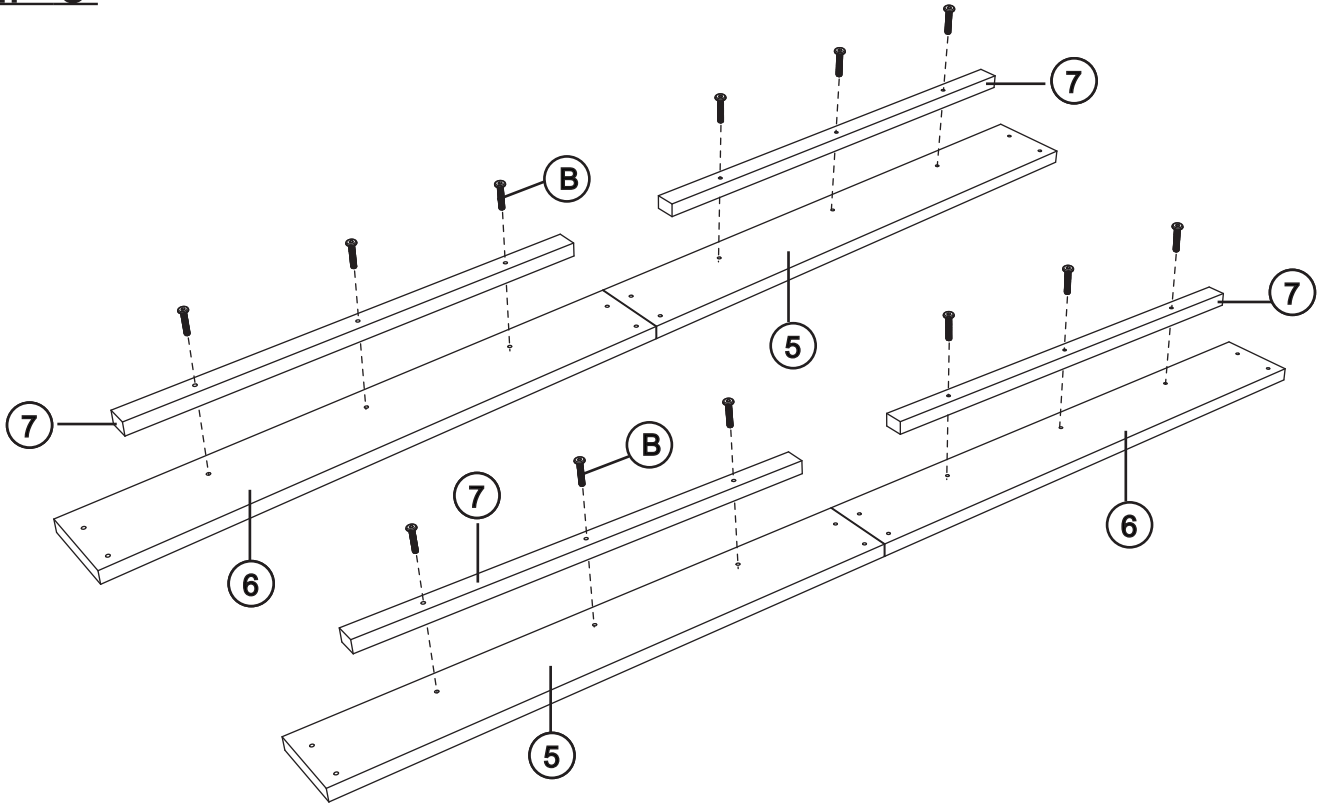

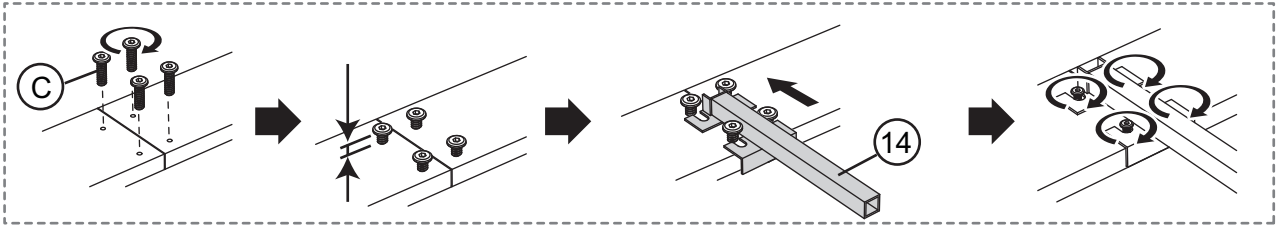

B	Bolt (Ø 8X40mm)		12
---	--------------------	---	----

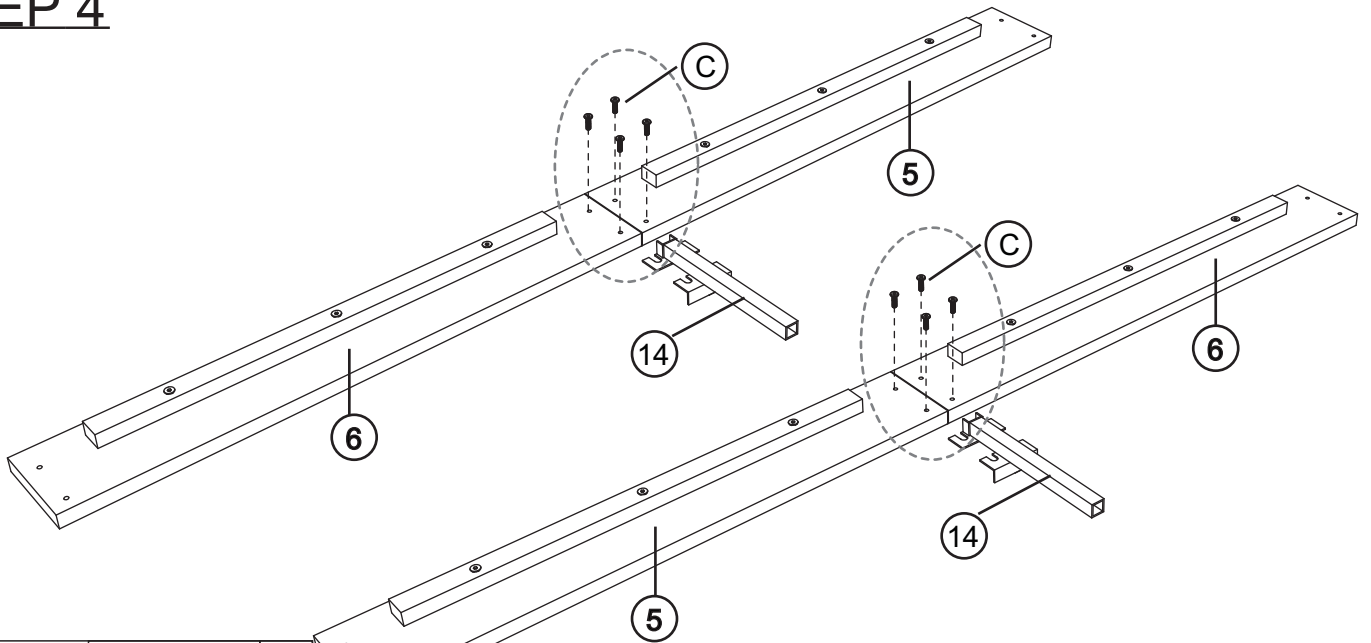

## STEP 4





14	Support Leg		2
C	Bolt (Ø 8X20mm)		8

# ASSEMBLY INSTRUCTIONS

## STEP 5

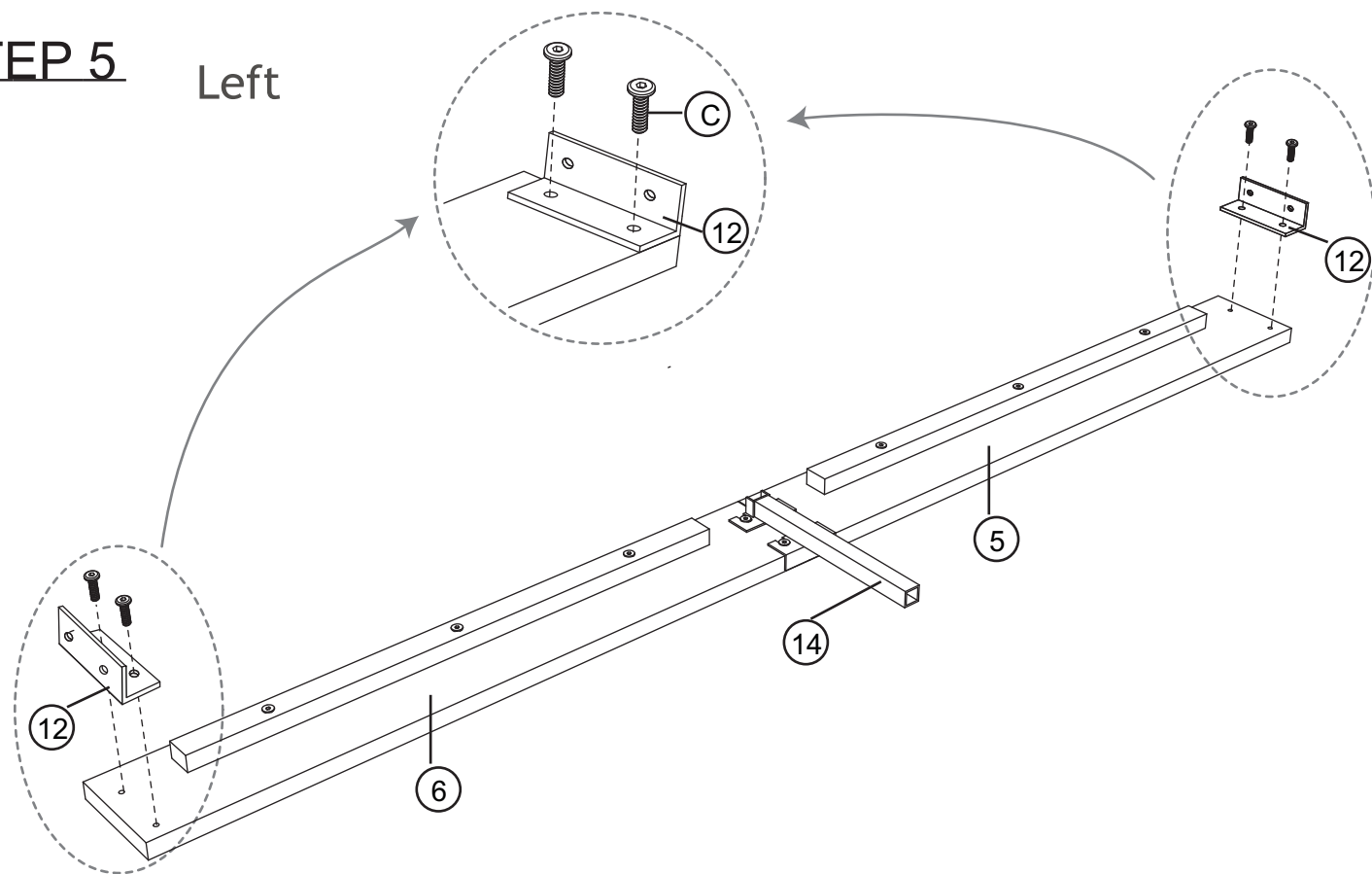
Left





12	Bracket		2
C	Bolt (Ø 8X20mm)		4

## STEP 6

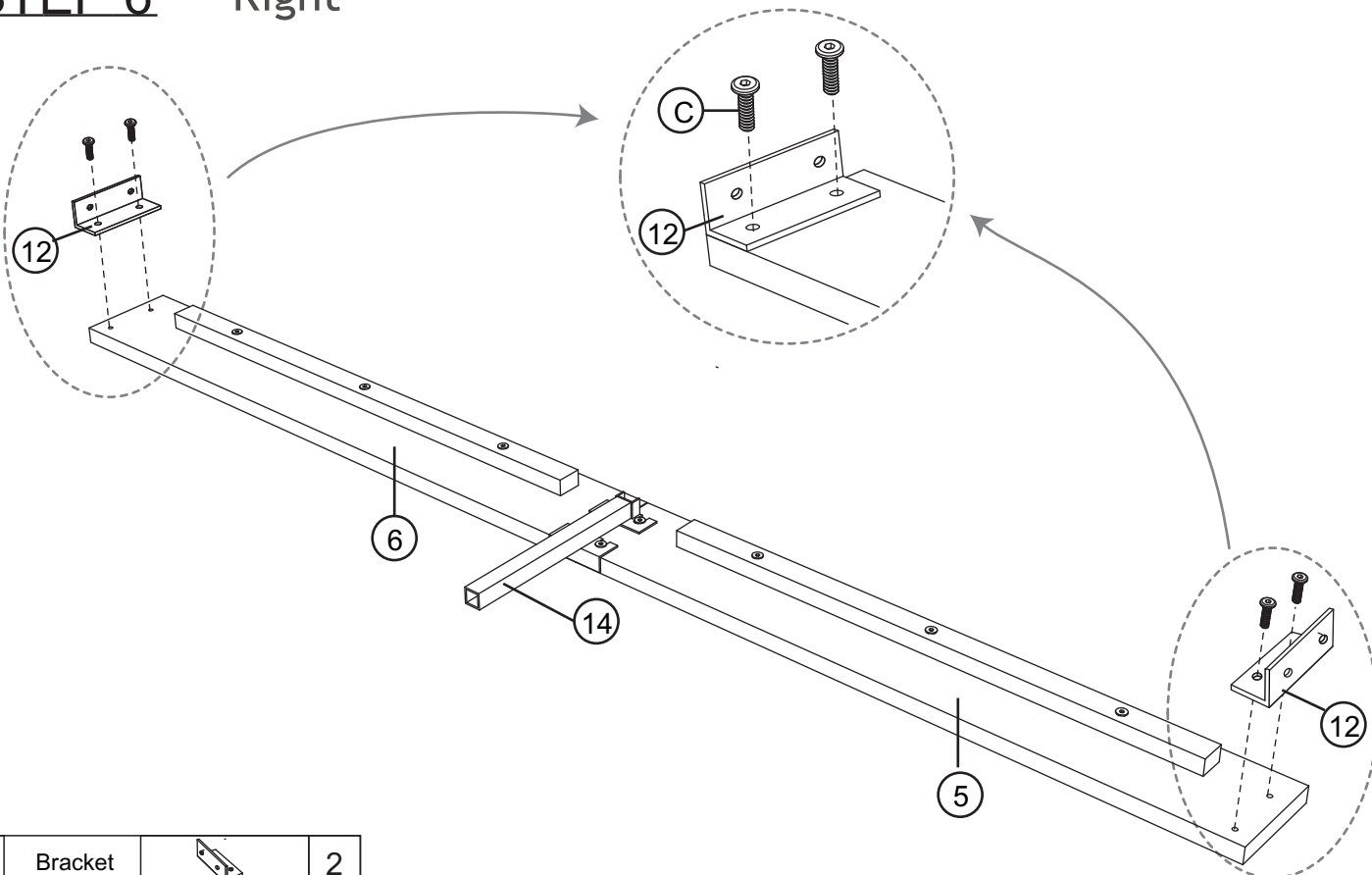
Right





12	Bracket		2
C	Bolt (Ø 8X20mm)		4

# ASSEMBLY INSTRUCTIONS

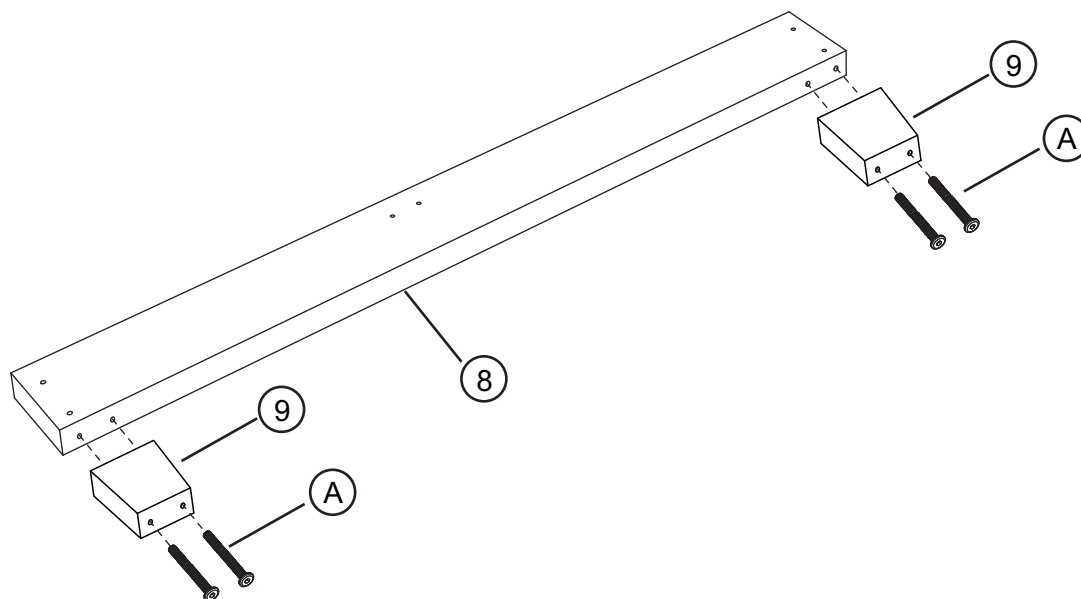
## STEP 7



9	Leg		2
A	Bolt (Ø 6X70mm)		4

## STEP 8

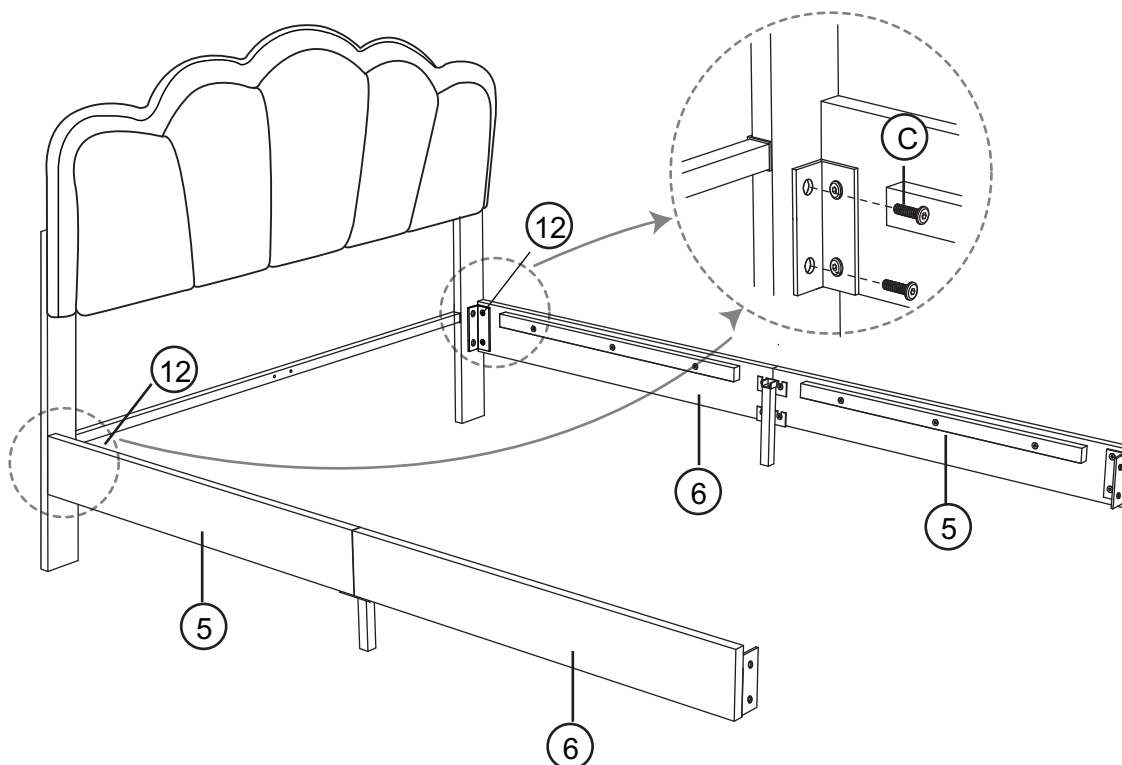

C	Bolt (Ø 8X20mm)		4
---	--------------------	---	---

# ASSEMBLY INSTRUCTIONS

## STEP 9

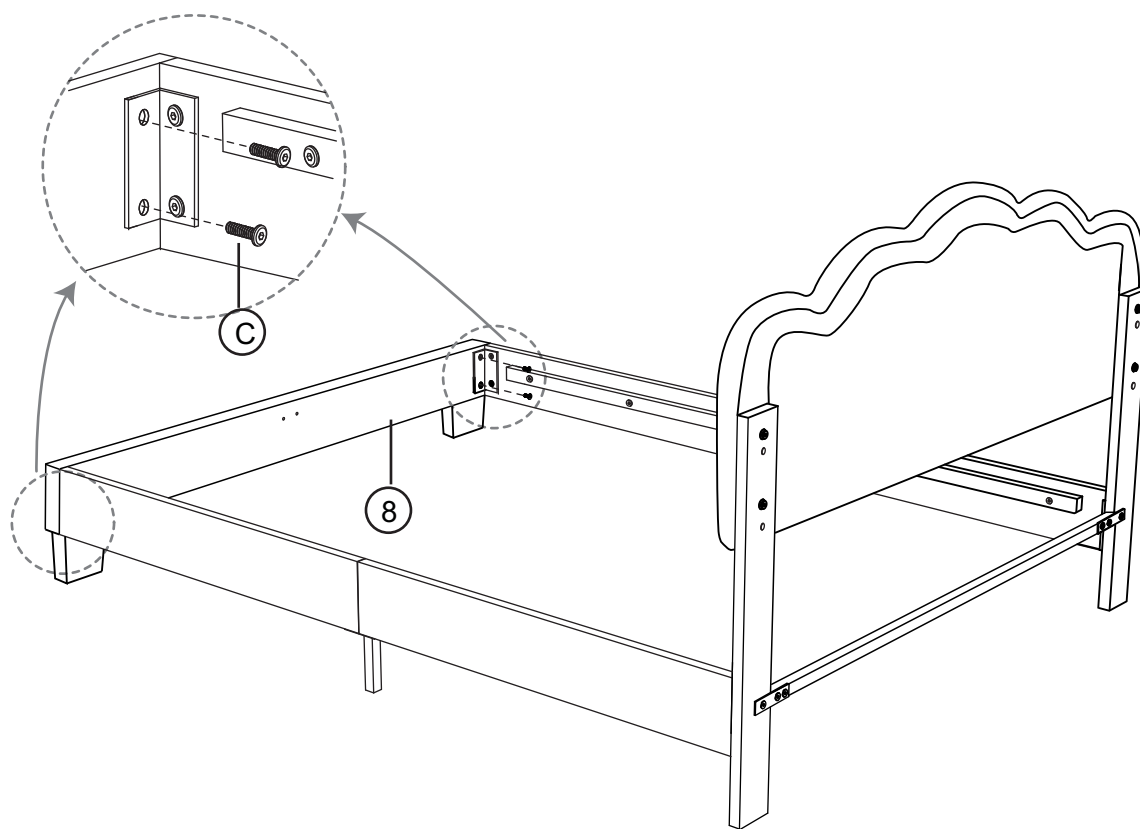

C	Bolt (Ø 8X20mm)		4
---	--------------------	---	---

## STEP 10

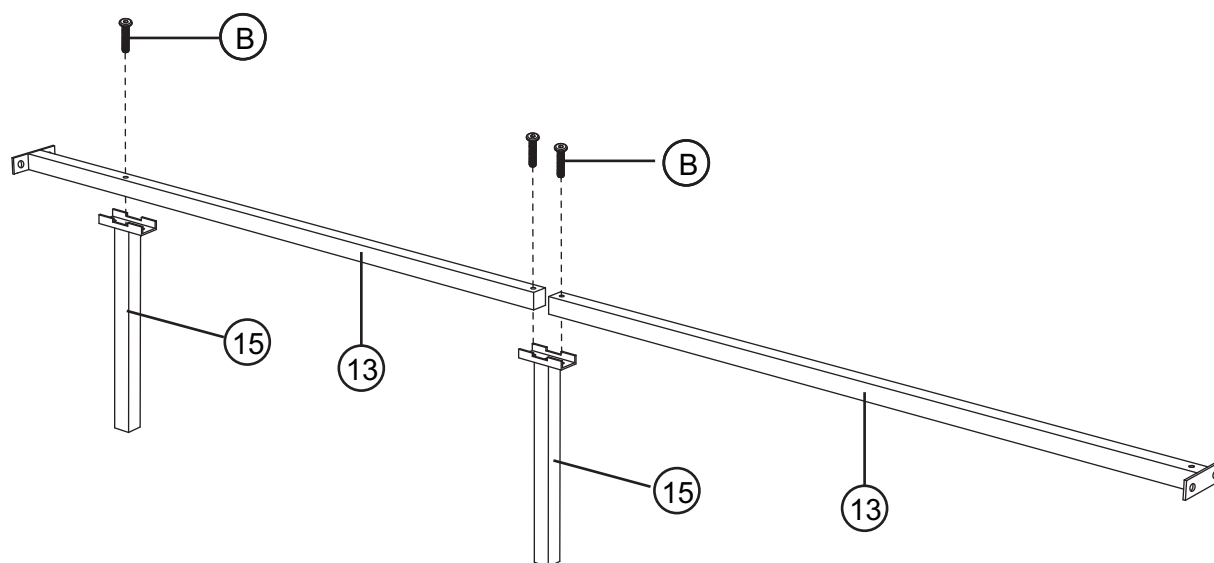

B	Bolt (Ø 8X40mm)		3
---	--------------------	---	---

# ASSEMBLY INSTRUCTIONS

## STEP 11

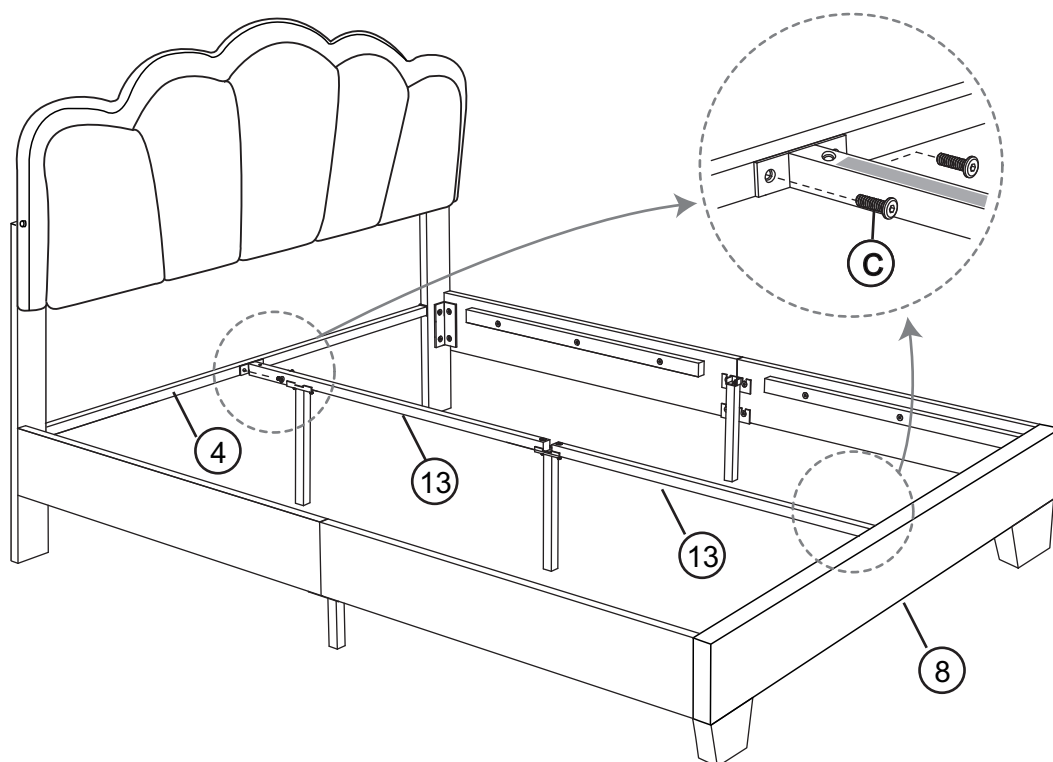

C	Bolt (Ø 8X20mm)		4
---	--------------------	---	---

## STEP 12

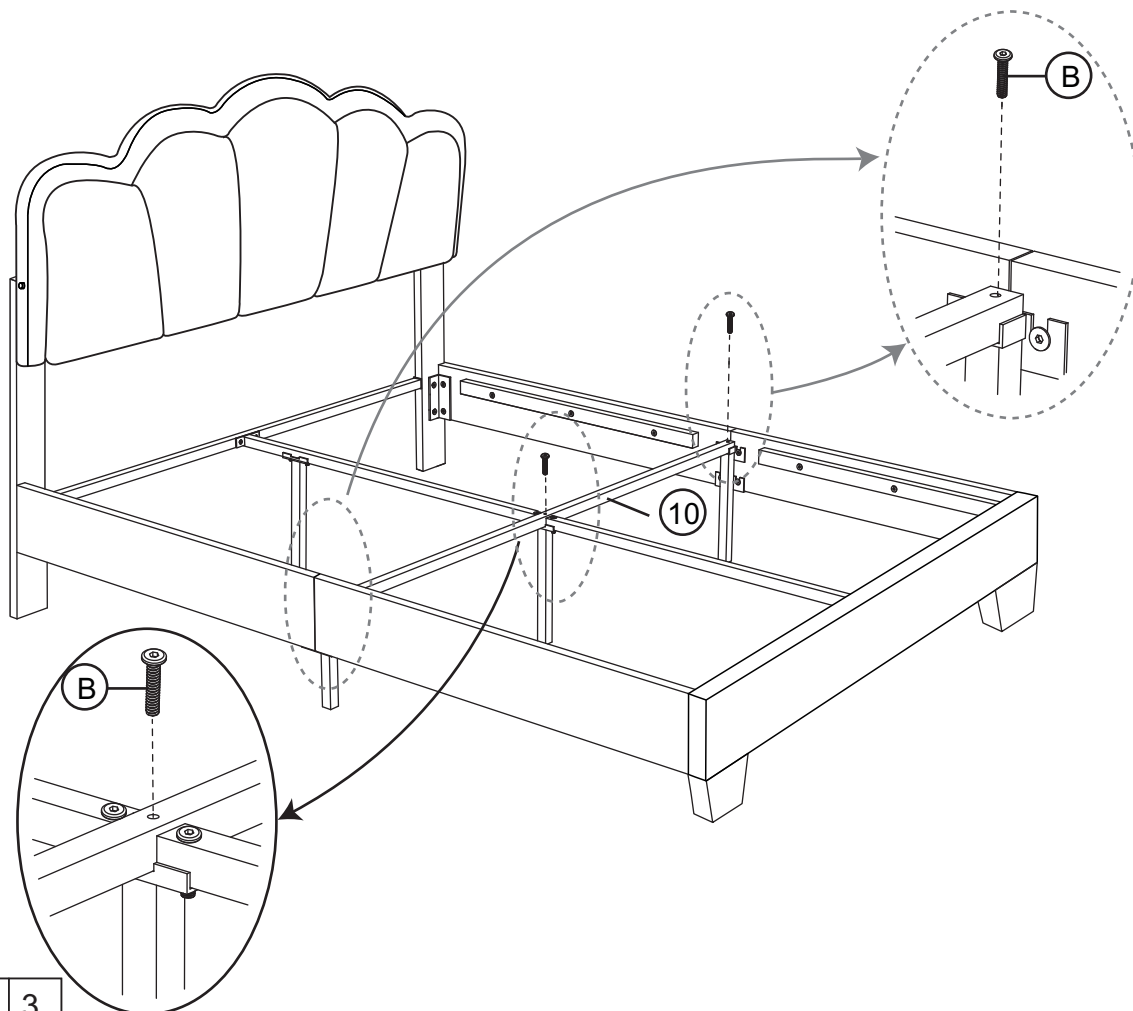

B	Bolt (Ø 8X40mm)		3
---	--------------------	---	---

# ASSEMBLY INSTRUCTIONS

## STEP 13

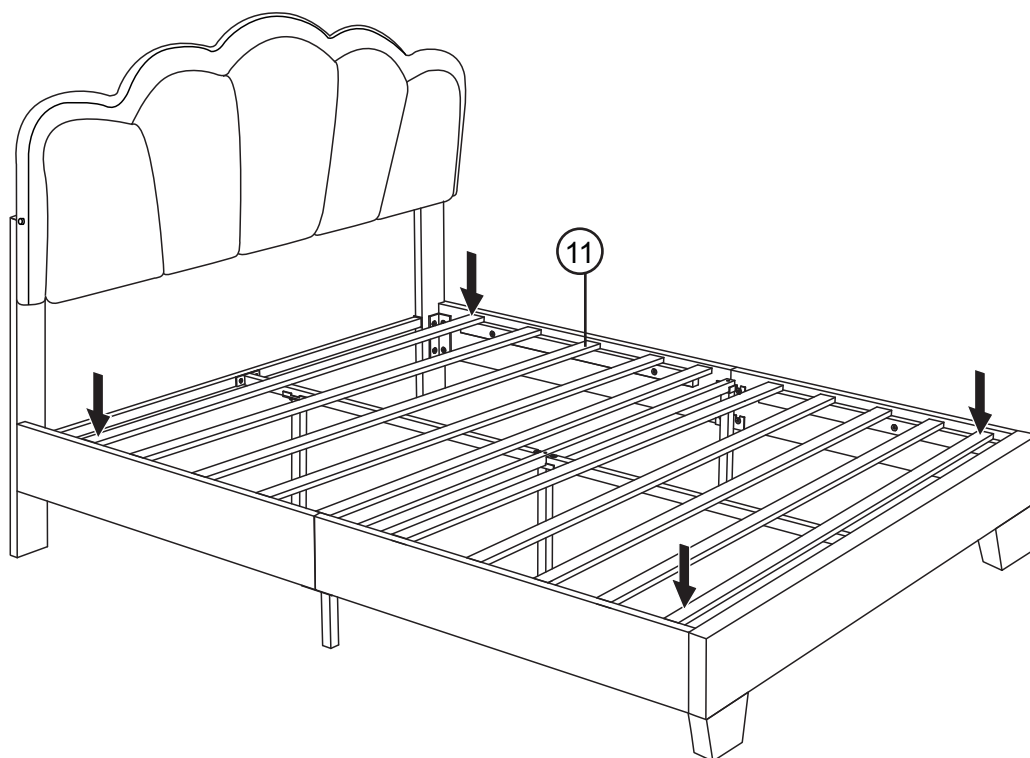

## STEP 14

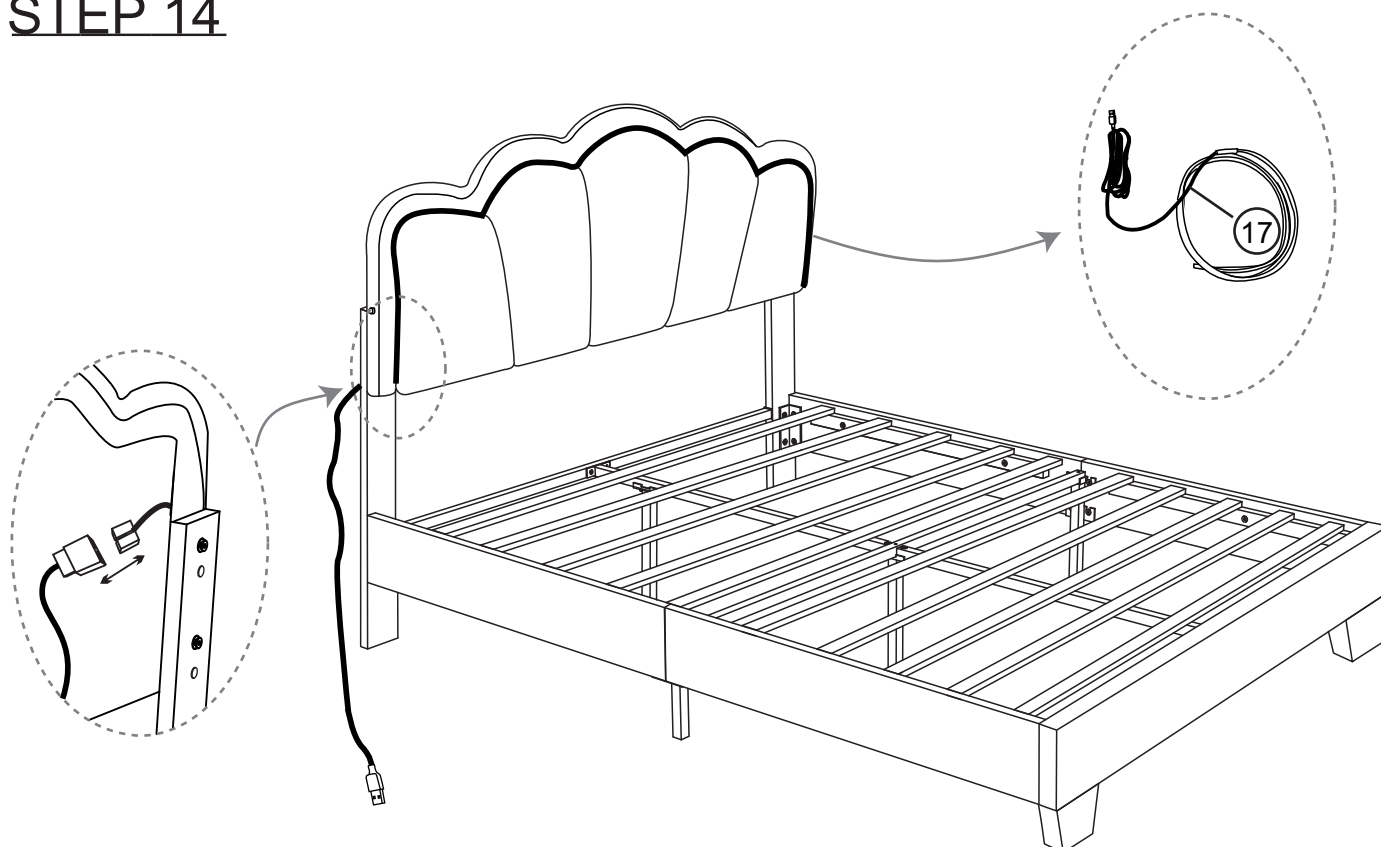

# ASSEMBLY INSTRUCTIONS

STEP 15

COMPLETE

