

OAKHAM

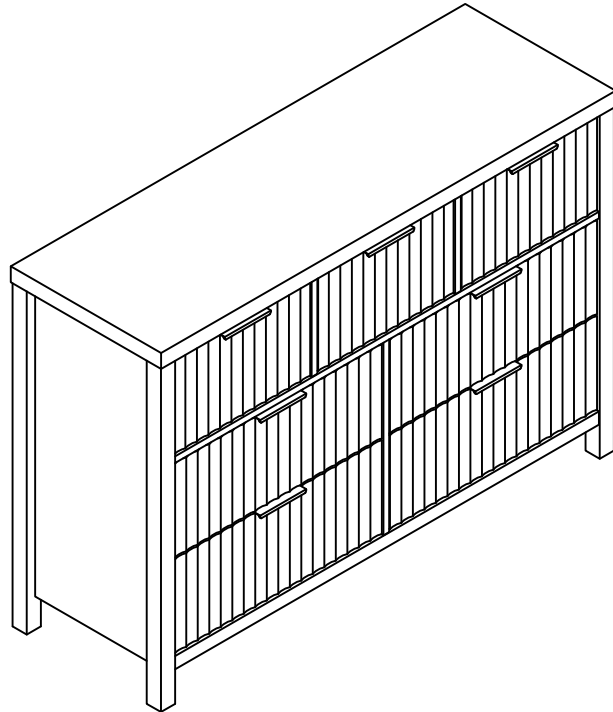

Video instructions can be found at:
<https://oakhamdesign.com/pages/assembly-videos>







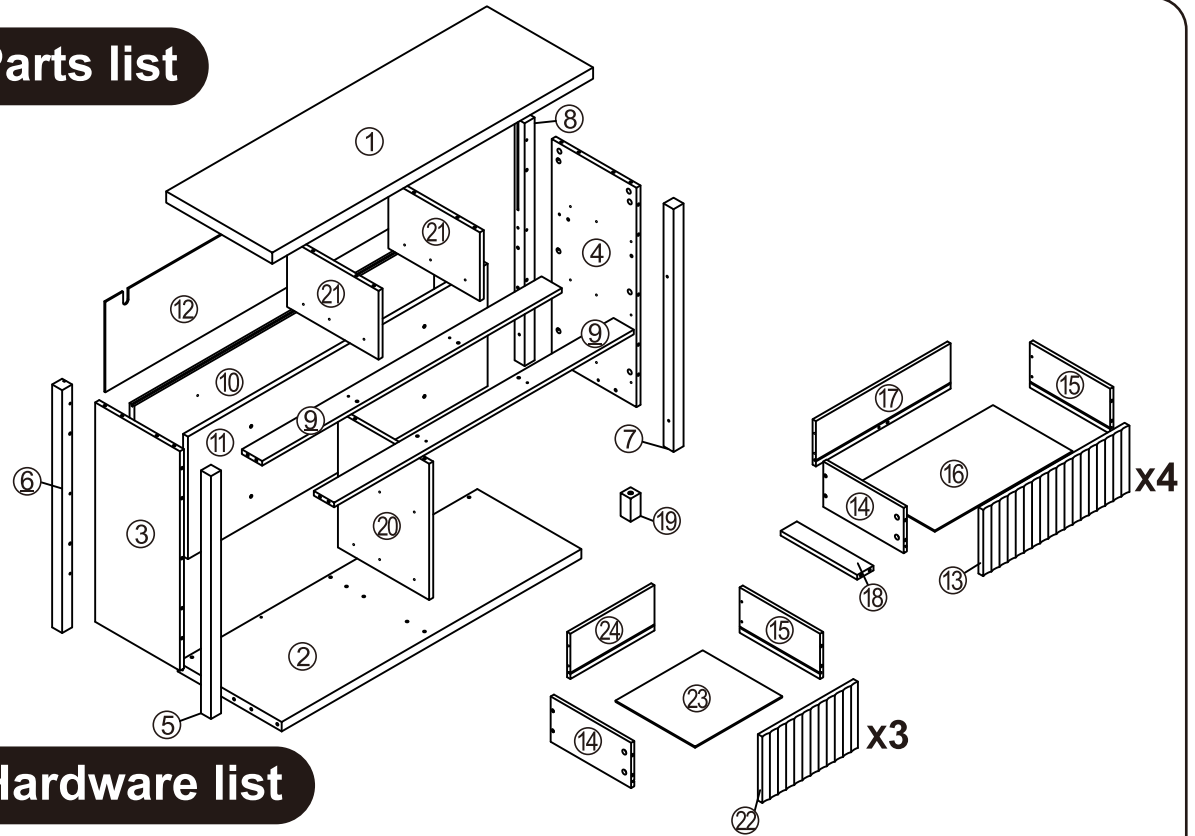





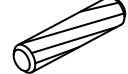

Your satisfaction is our priority!

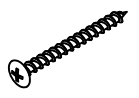
If for any reason there is anything missing, incorrect, or different from your expectation, please contact us first at care@oakhamdesign.com

Parts list

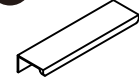

Hardware list

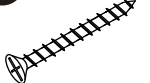
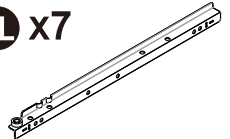
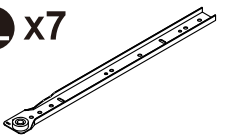
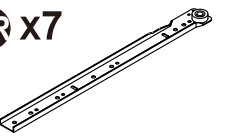
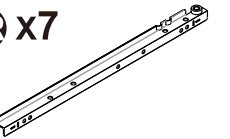
A x68 	B x68 	C x47 ϕ 8*30MM 	D x98 ϕ 3.5*12MM 	E x36 ϕ 4*30MM 	
F x4 ϕ 4.2*50MM 	G x2 ϕ 4*35MM 	H x2 ϕ 4*15MM 	I x2 	J x2 	
K x54 	L x7 	M x1 	N x4 ϕ 3*16MM 	O x4 	P x4 ϕ 4*40MM 
DL x7 	CL x7 	CR x7 	DR x7 		

Step 1

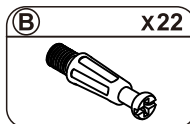
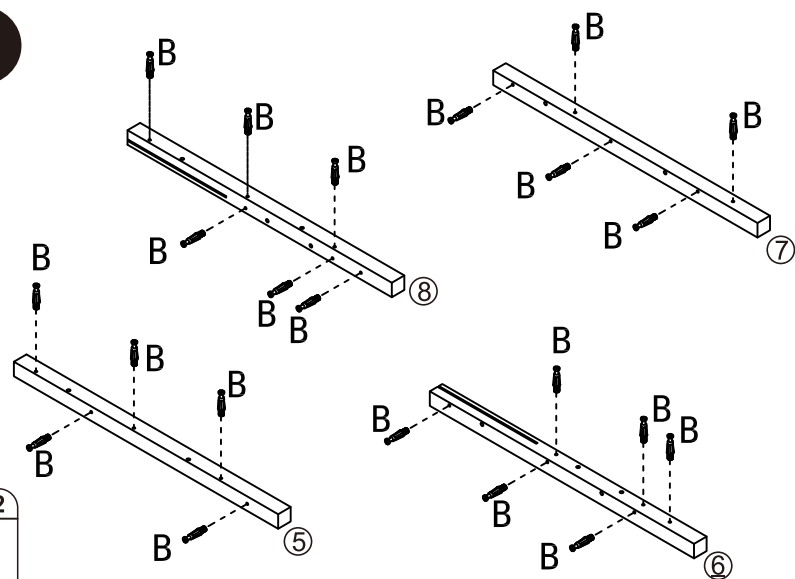

Step 3

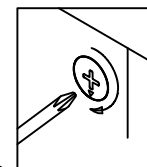
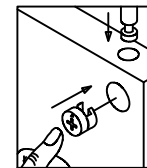
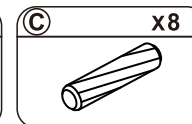
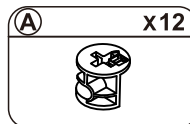
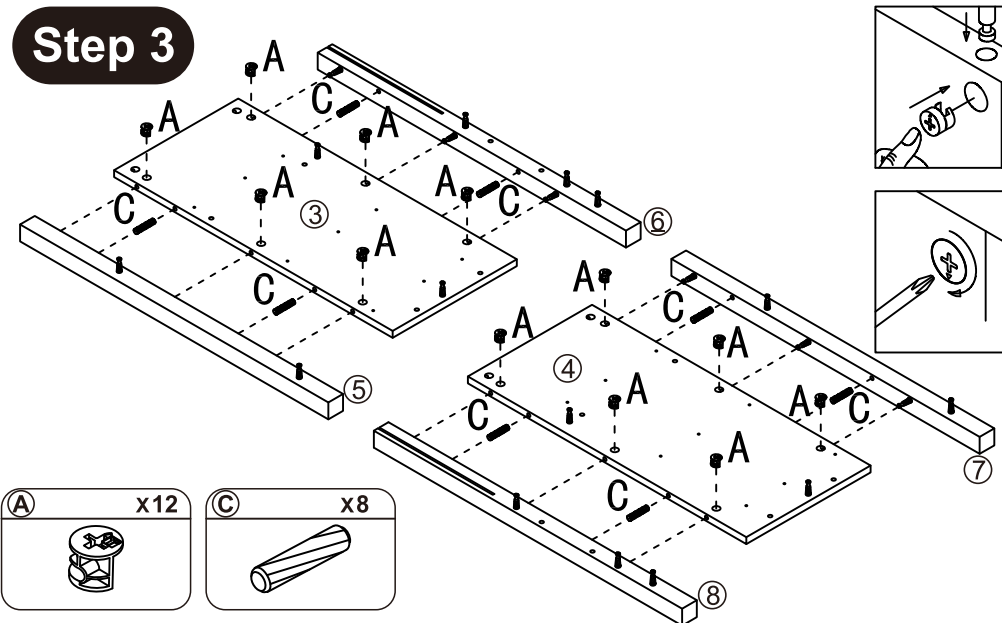

Step 2

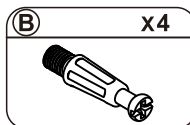
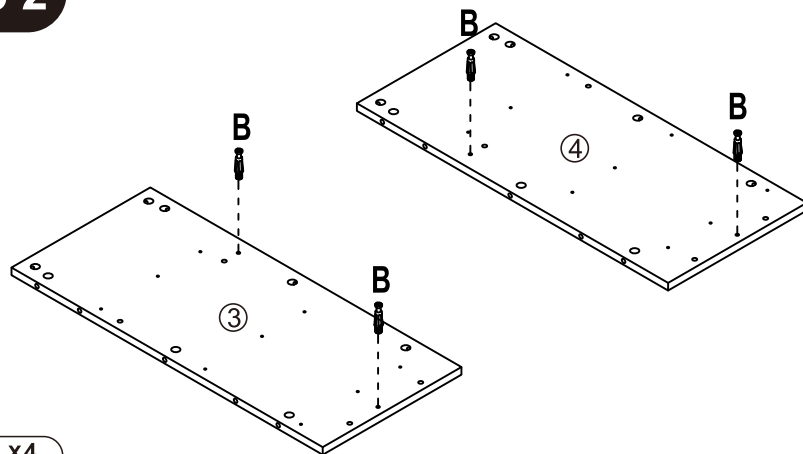

Step 4

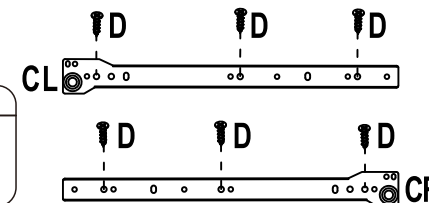
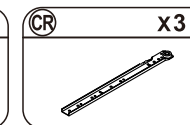
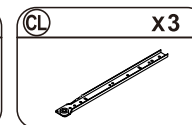
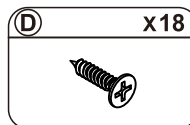
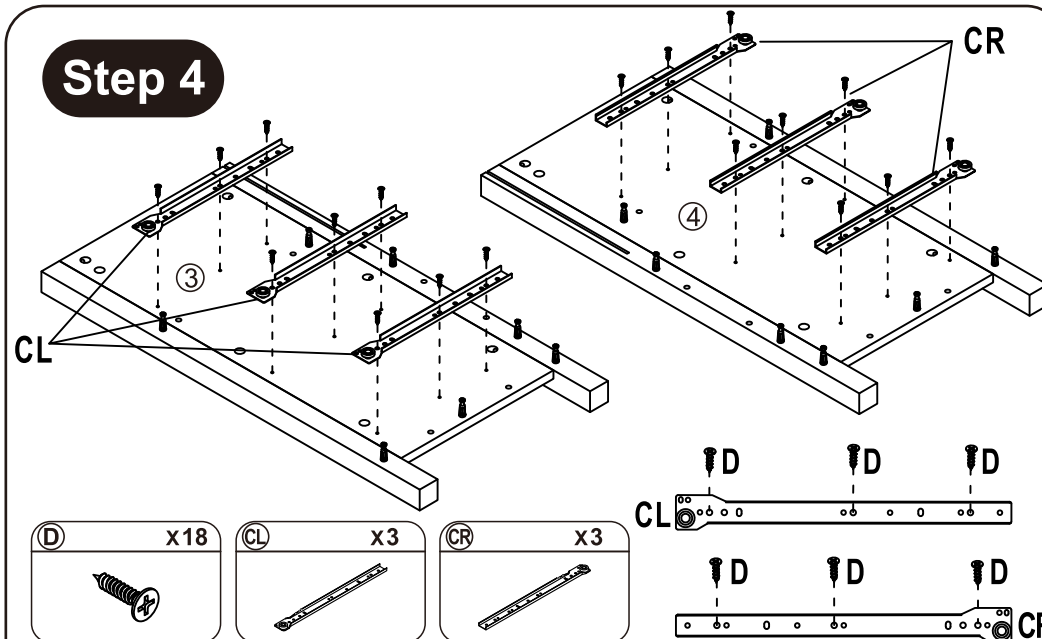

Step 5

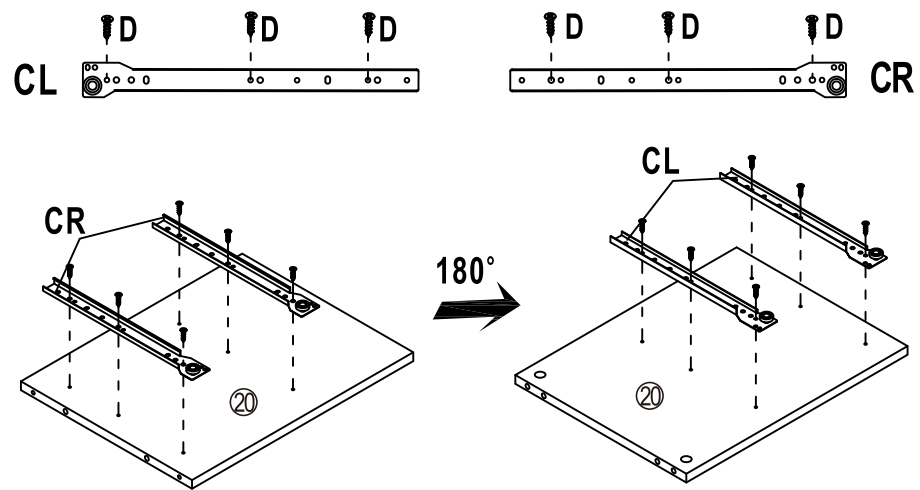
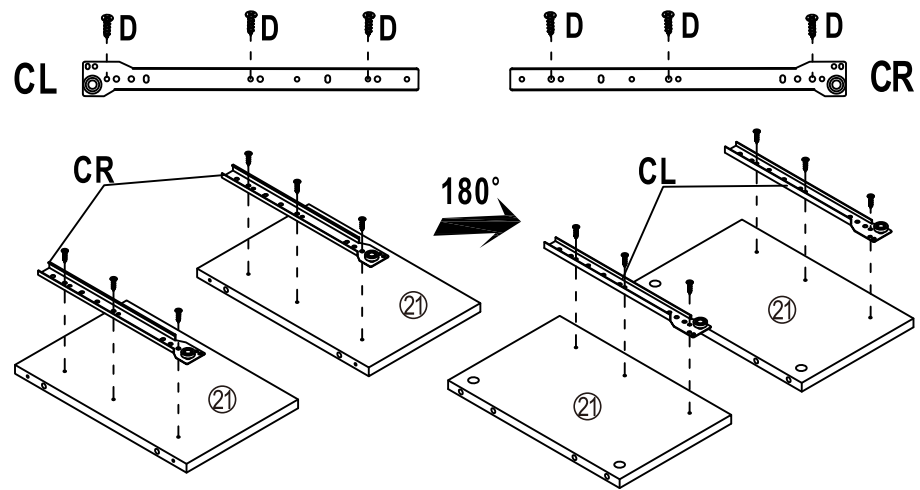

- (D) x24
- (CL) x4
- (CR) x4

Step 6

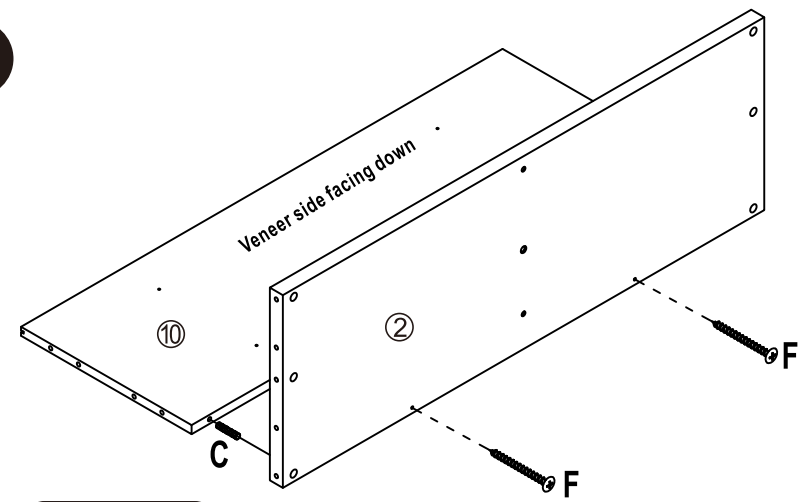

- (C) x3
- (F) x2

Step 7

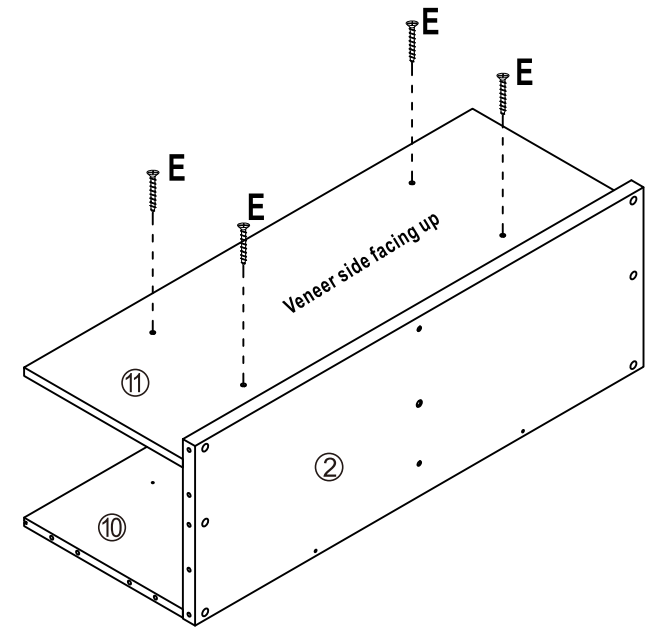

- (E) x4

Step 8

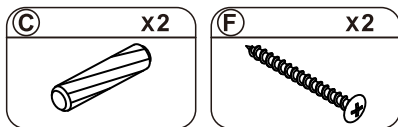
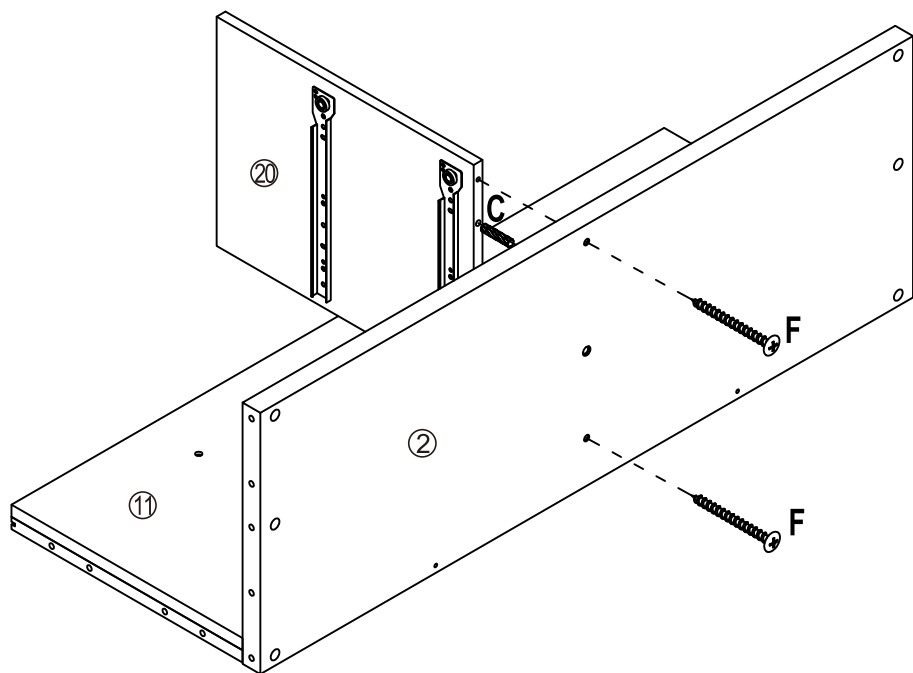

Step 9

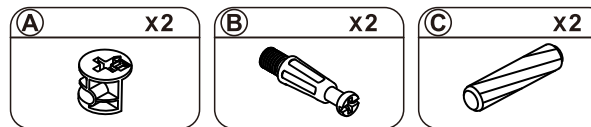
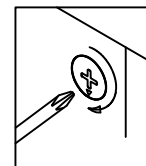
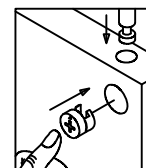
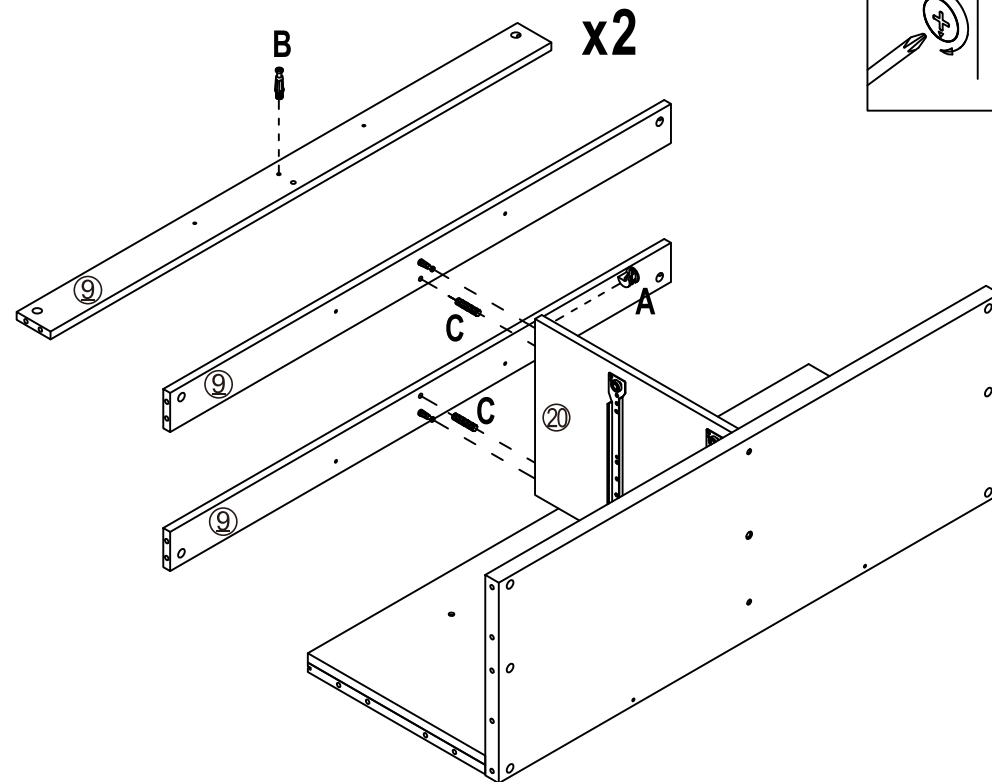

Step 10

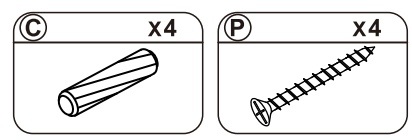
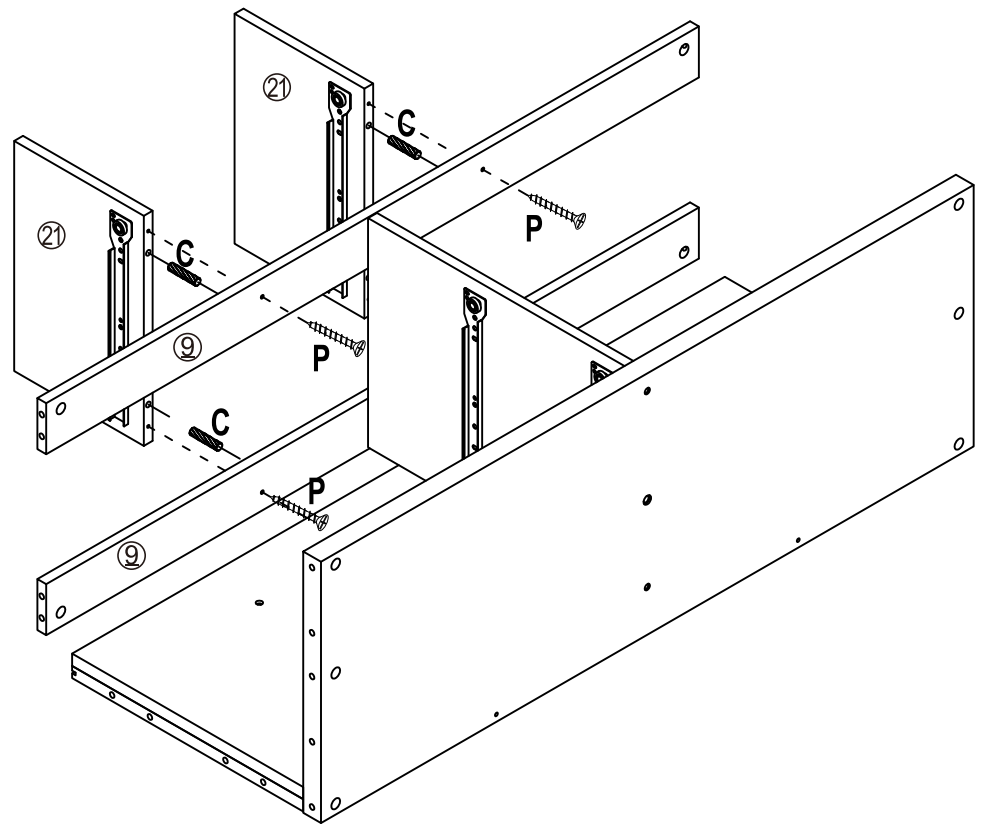

Step 11

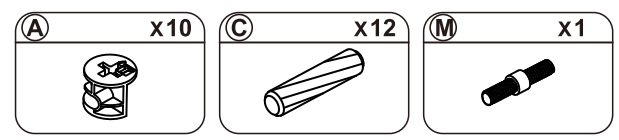
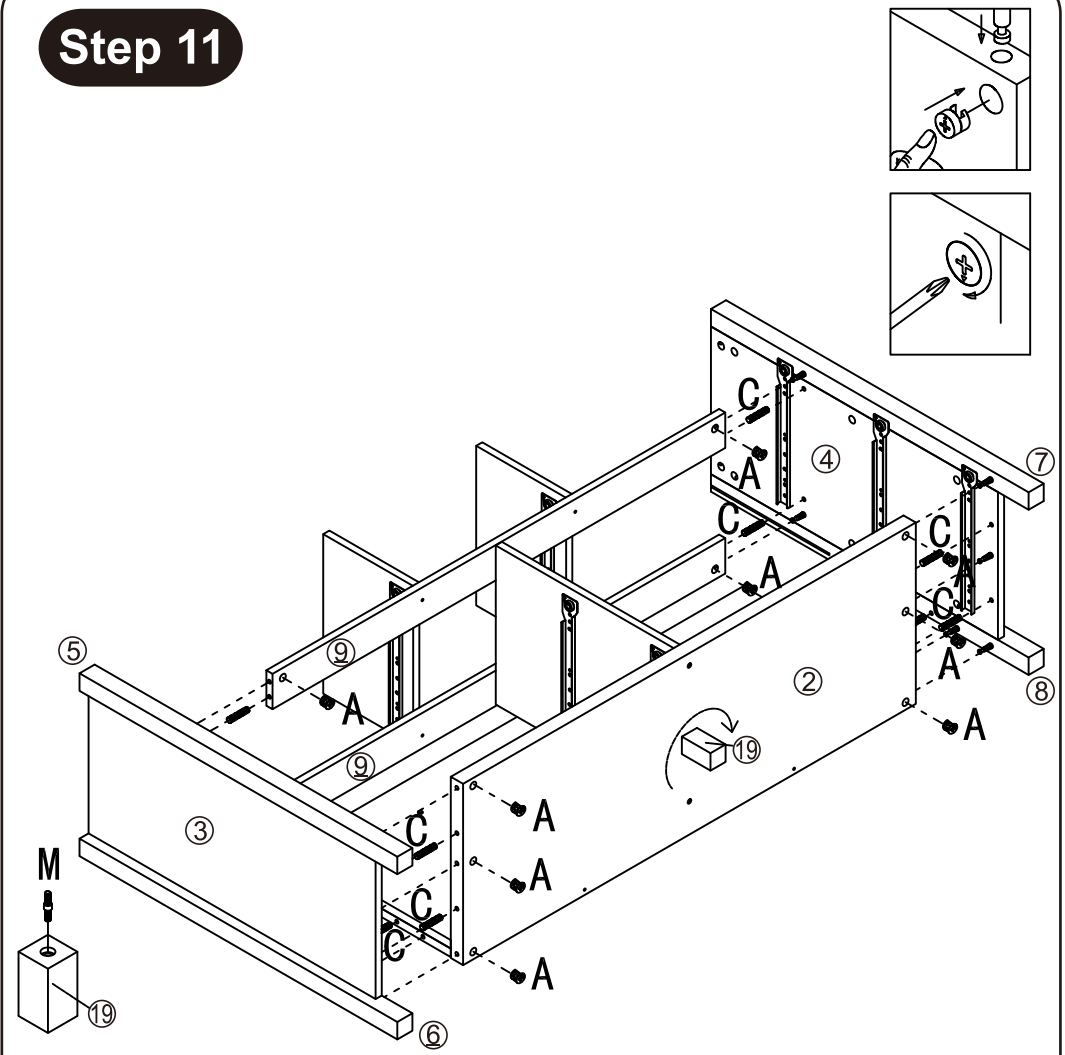

Step 12

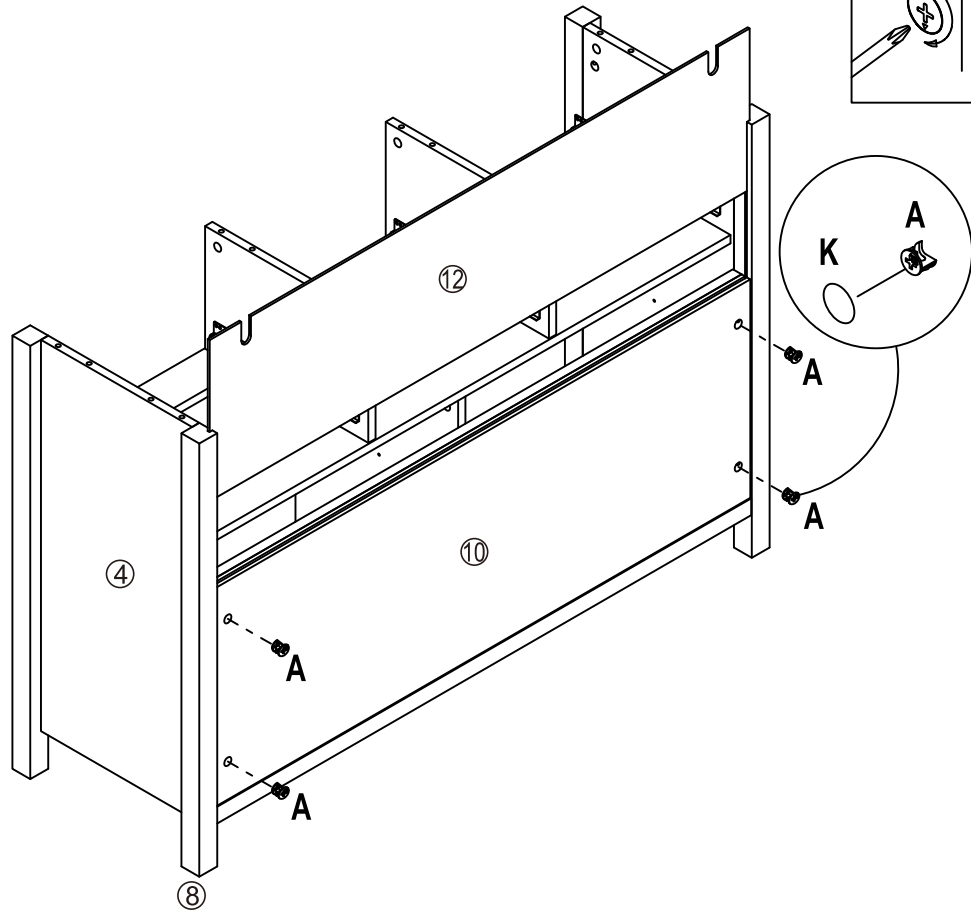
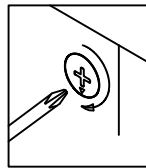
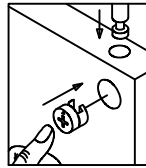

- | | | | |
|------------|----|------------|----|
| (A) | x4 | (K) | x4 |
| | | | |

Step 13

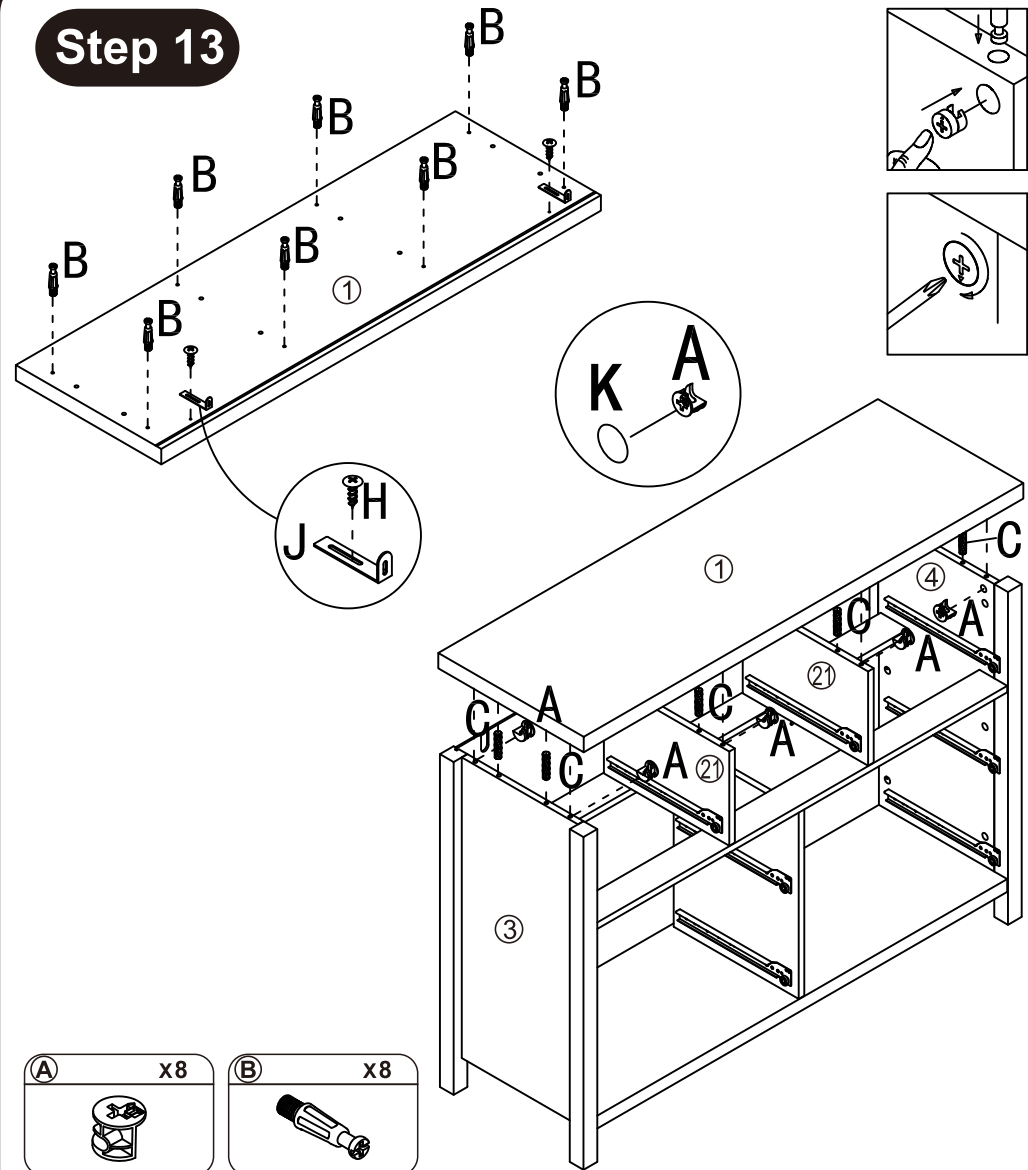
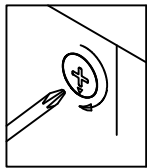
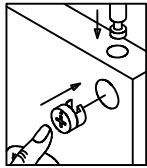

- | | | | |
|------------|----|------------|-----|
| (A) | x8 | (B) | x8 |
| | | | |
| (C) | x8 | (H) | x2 |
| | | | |
| (J) | x2 | (K) | x22 |
| | | | |

Step 14

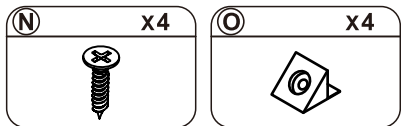
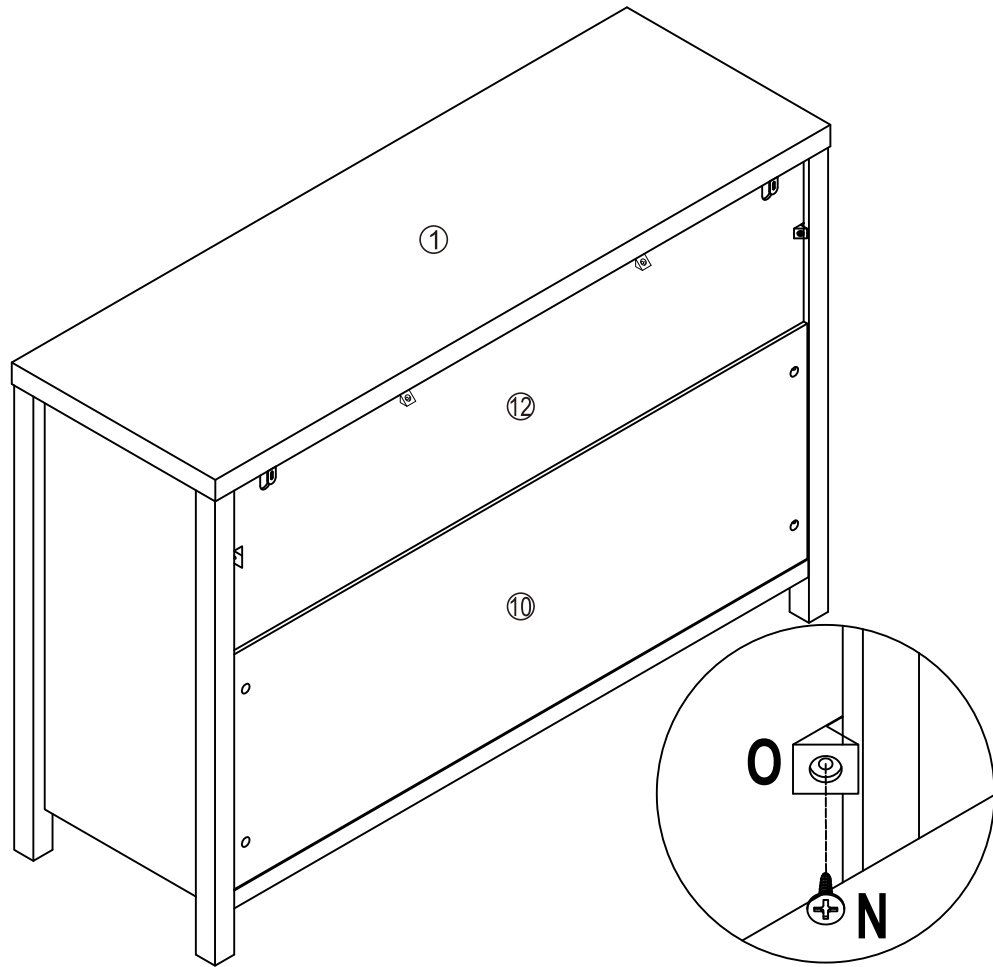

Step 15

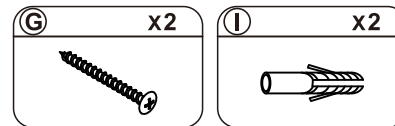
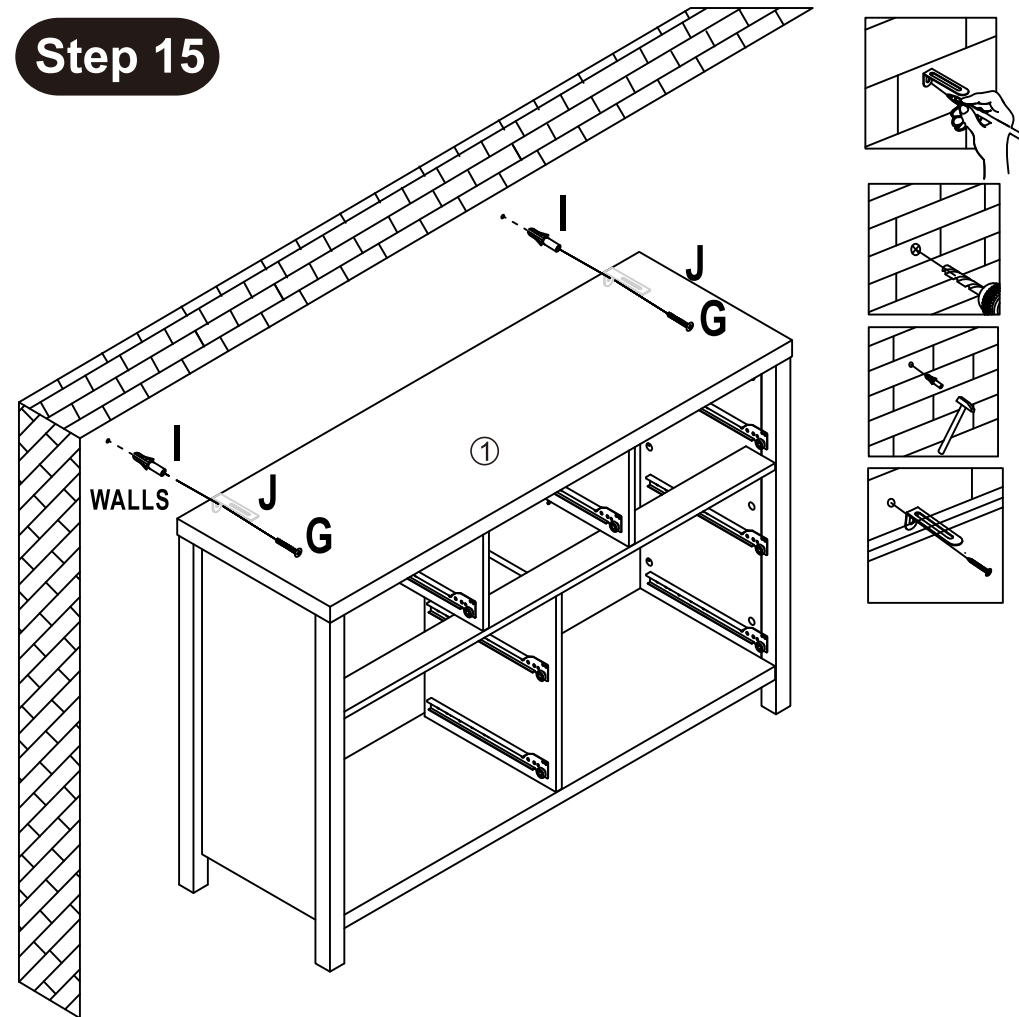

Step 16

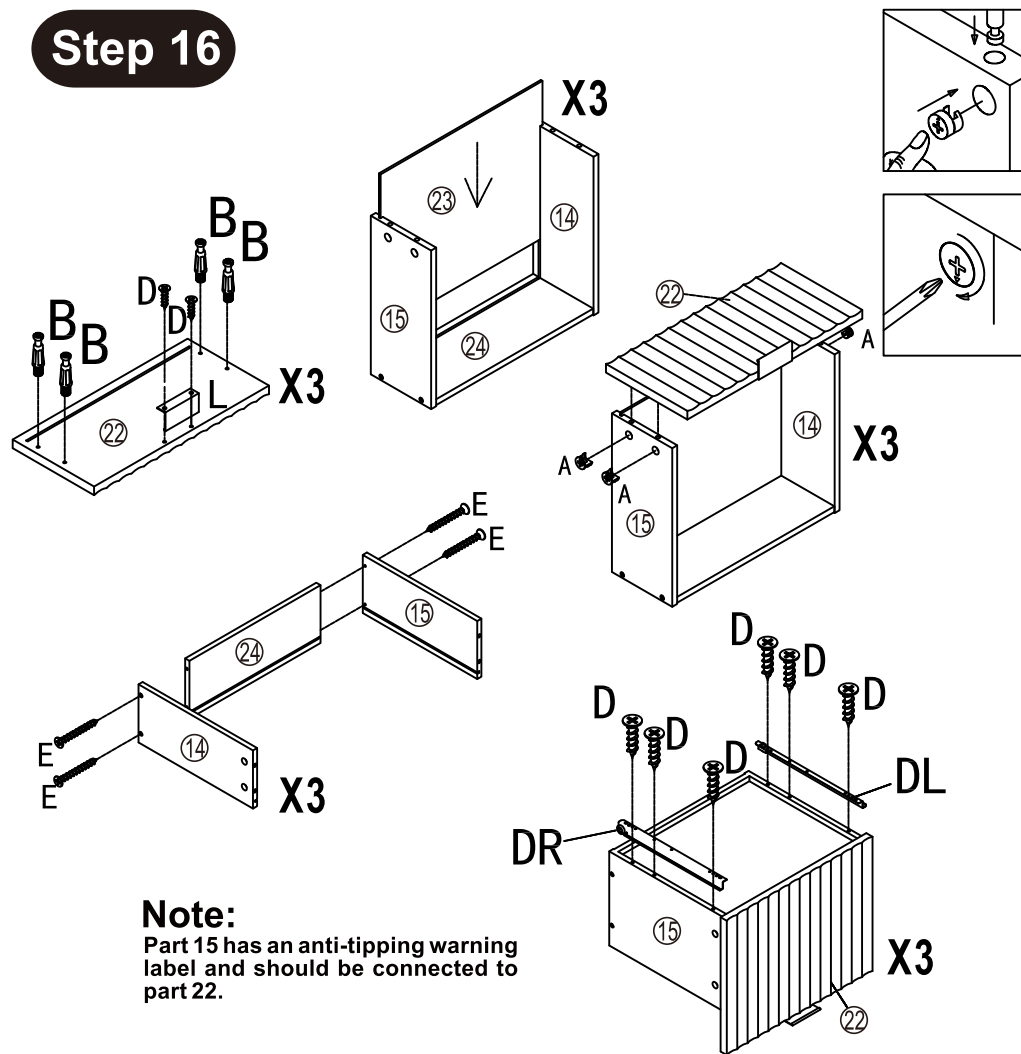

Note:
Part 15 has an anti-tipping warning label and should be connected to part 22.

(A) x12	(B) x12	(D) x24
(E) x12	(L) x3	(DL) x3
(DR) x3		

Step 17

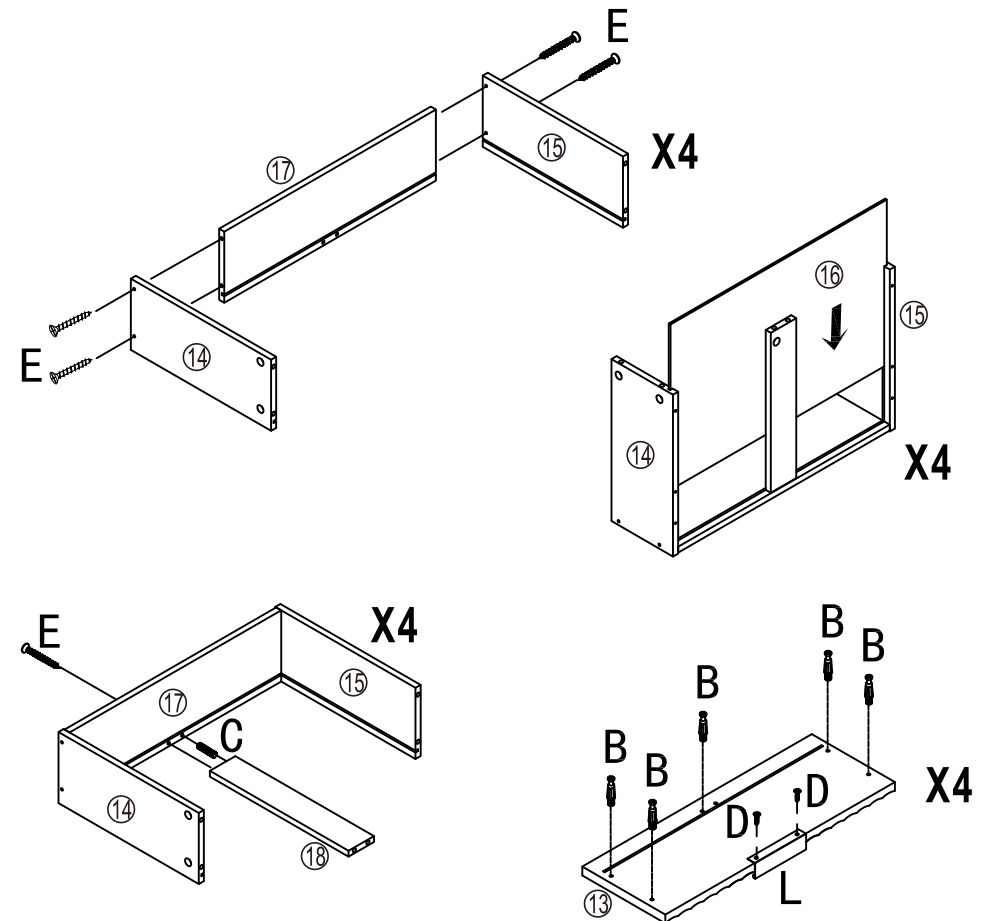

(B) x20	(C) x4	(D) x8	(E) x20	(L) x4
---------	--------	--------	---------	--------

Step 18

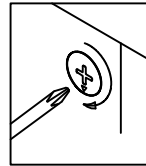
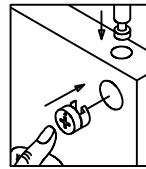
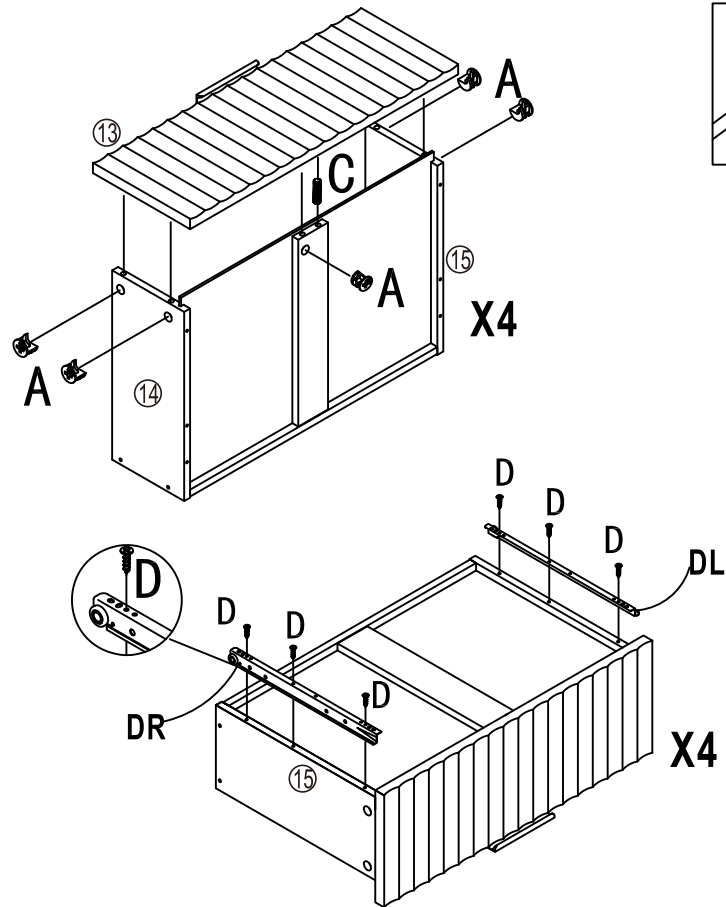

- | | | | | |
|---------|--------|---------|---------|---------|
| (A) x20 | (C) x4 | (D) x24 | (DL) x4 | (DR) x4 |
| | | | | |

Step 19

Note:
Drawers with the anti-tipping warning label inside should be placed on the top layer.

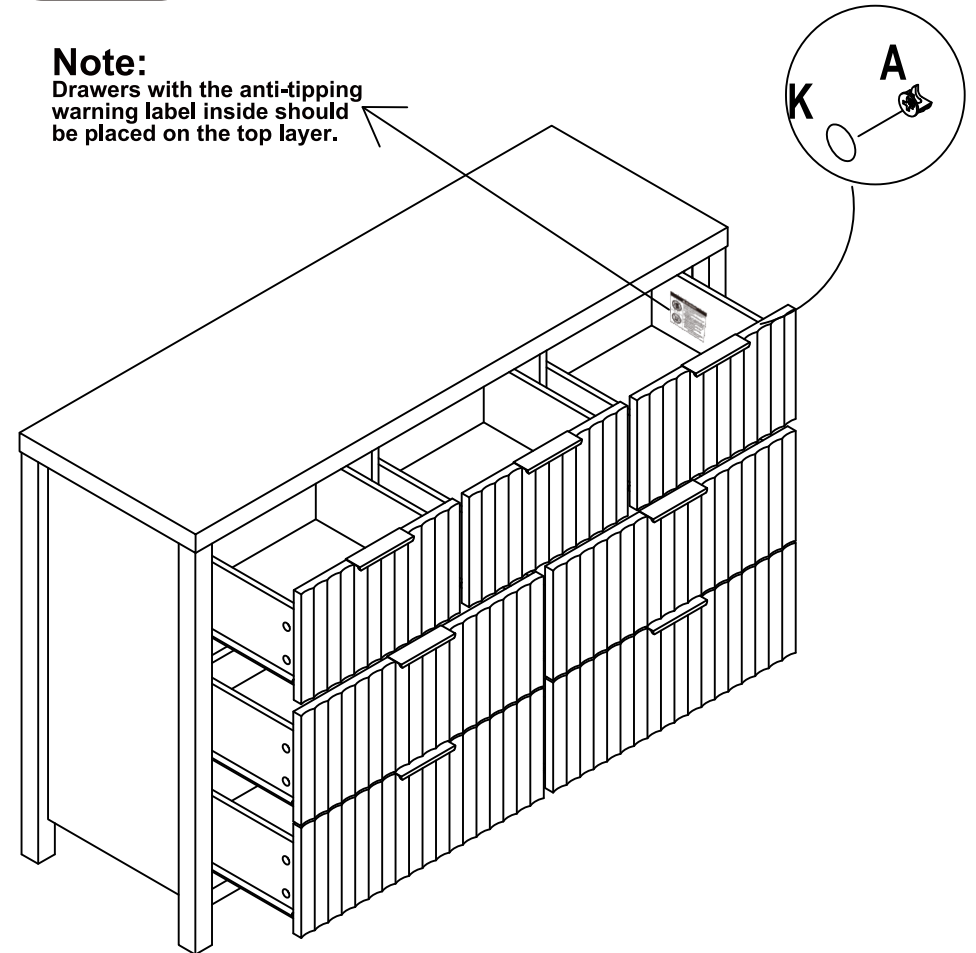

- | |
|---------|
| (K) x28 |
| |

WARNING



**Children have died from furniture tipover.
To reduce the risk of furniture tipover:**

- **ALWAYS** install Anti-tip device provided.
- **NEVER** put a TV on this product.
- **NEVER** allow children to stand, climb or hang on any drawers, doors, or shelves.
- **NEVER** open more than one drawer at a time.
- Place heaviest items in the lowest drawers.



***This is a permanent label.
Do not remove!***

※ **Stay Scratch-Free: Safeguard Your Furniture by Assembling on Carpet.**

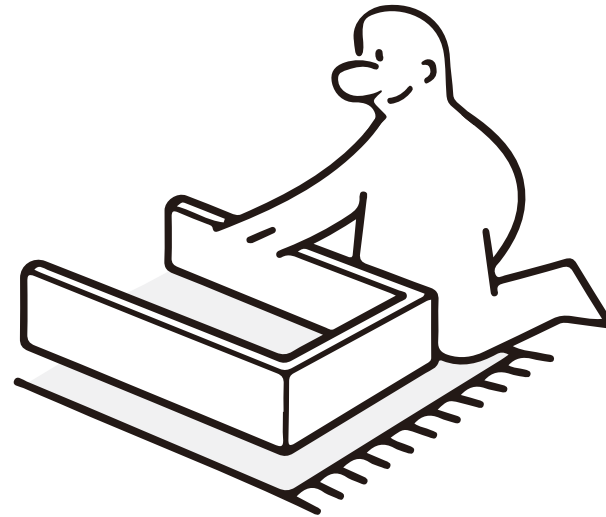
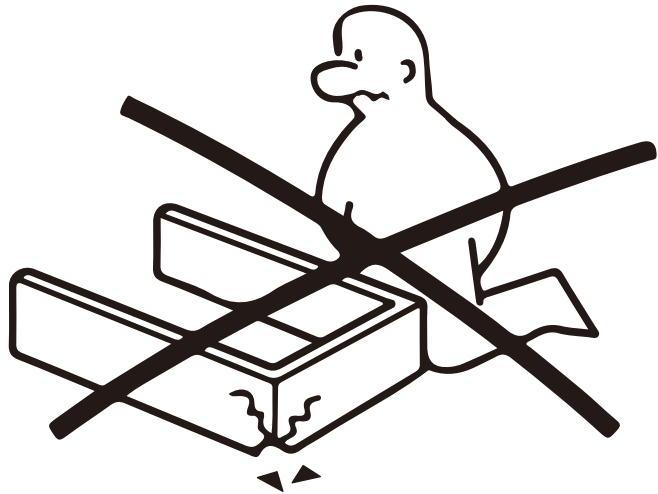

※ **Stuck in Assembly Limbo? Check out our website or contact our support team for quick solutions!**

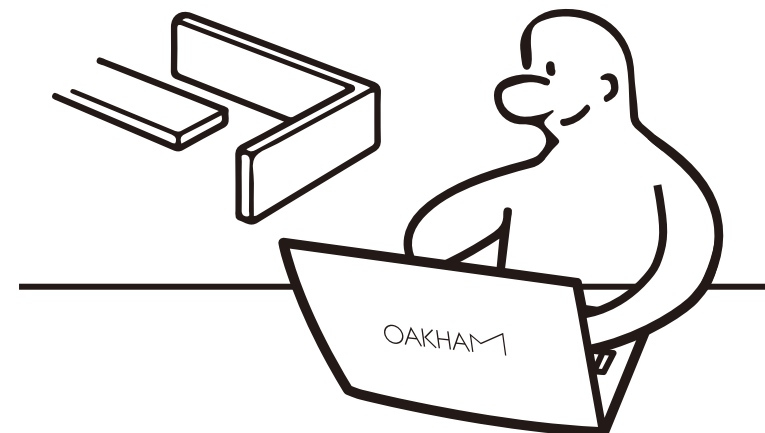
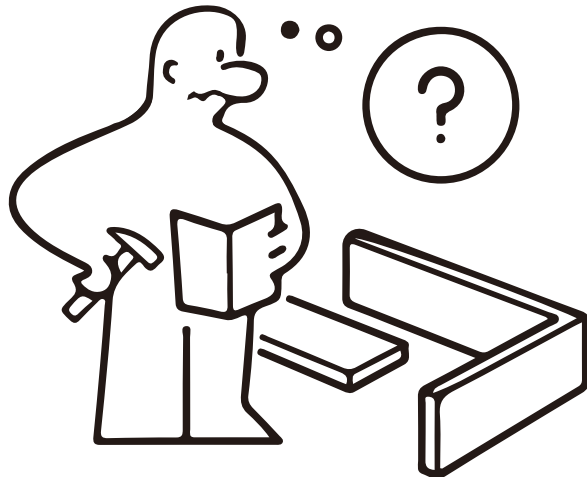

THANK YOU!

For purchasing from us

Despite our reinforced packaging, transit mishandling can sometimes occur. In the rare event that your product arrives damaged, we're here to assist you. **If your product is in perfect condition, you can disregard this message.**

If you discover any damage upon receipt of your package, please contact our after-sales mailbox immediately at care@oakhamdesign.com.

Additionally, we kindly request your assistance in filing a claim against the shipping carrier for the mishandling of your package. Please help us by providing clear photos as follows:

- ☆ Complete Shipping Label (Express Delivery Waybill): Take a clear image of the entire shipping label affixed to the package with visible and legible text and barcodes.
- ☆ Exterior Packaging Damage: Capture a comprehensive photo showing the damaged exterior of the shipping package.
- ☆ Interior Item Damage: Provide images focusing on the damaged areas of product

Your cooperation is invaluable, and we assure you that we're committed to resolving this issue promptly. Your satisfaction remains our top priority.

Thank you for your understanding and assistance.

Best regards,

Oakham Customer Support Team

care@oakhamdesign.com

Example:

