

ATTENTION

PLEASE READ BEFORE OPENING + ASSEMBLING

IS A FAMILY OF BRANDS BUILT WITH YOUR FAMILY IN MIND.
WE APPRECIATE YOUR ORDER!

WE STAND BEHIND OUR PRODUCTS 100%

YOUR SATISFACTION IS OUR #1 GOAL.

**IF YOUR ORDER IS NOT PERFECT, OR IF YOU WOULD LIKE ANY
ASSISTANCE; PLEASE FEEL FREE TO CONTACT US:**

WE ARE HAPPY TO HELP!

6-DRAWER DRESSER
COMMODE À 6 TIROIRS
CÓMODA DE 6 CAJONES

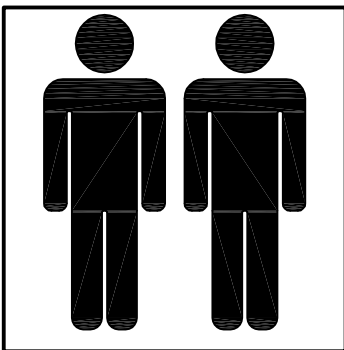
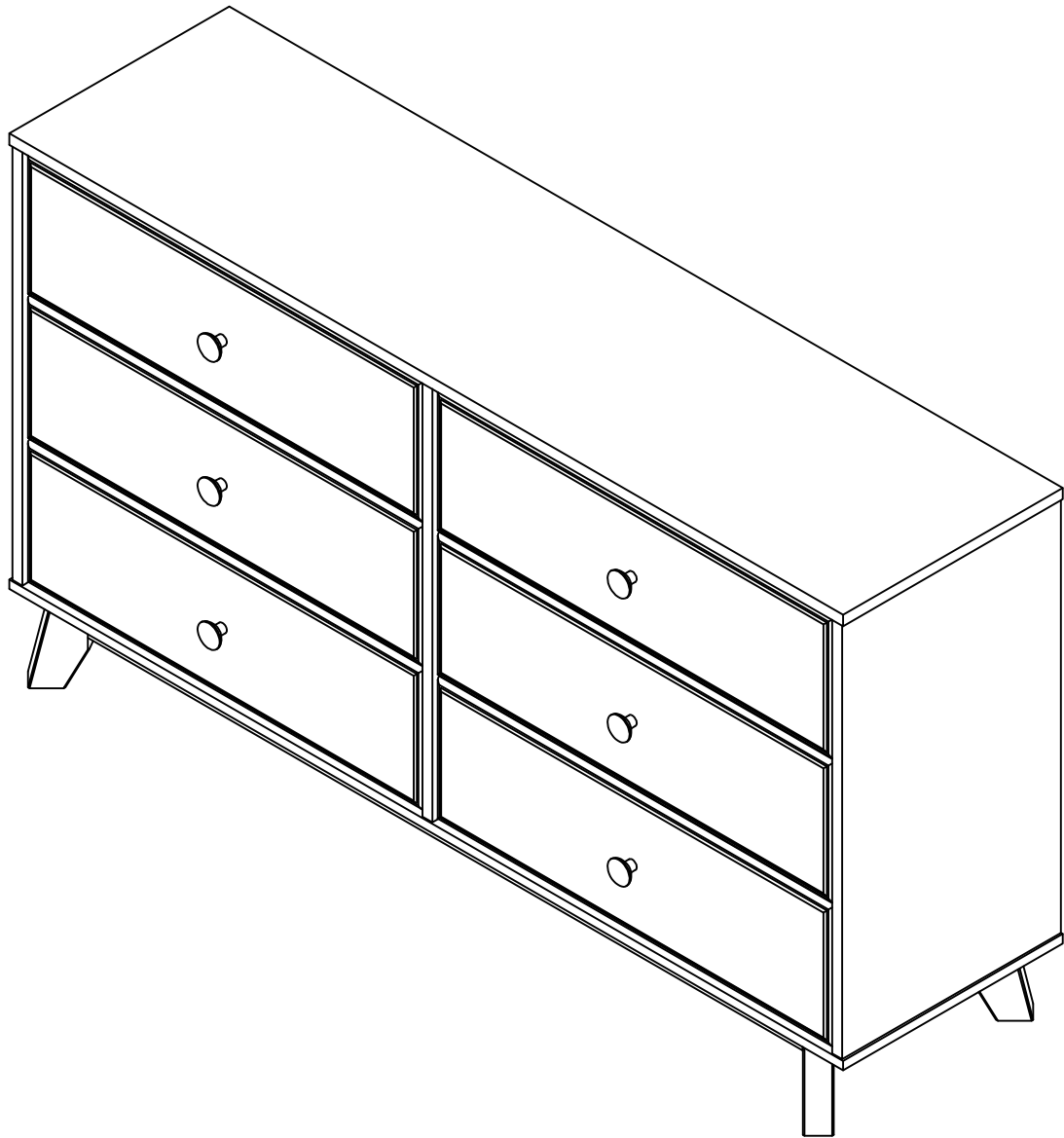

2 PERSON ASSEMBLY
ASSEMBLAGE NECESSITANT 2 PERSONNES
MONTAJE DE 2 PERSONAS

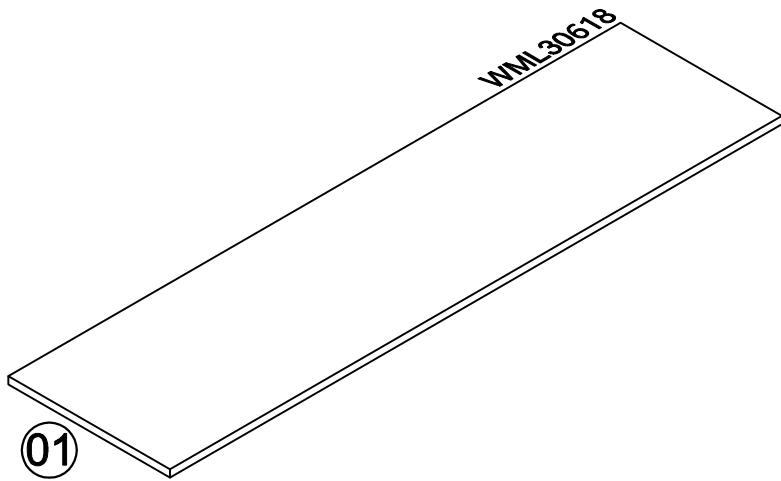

01

1x

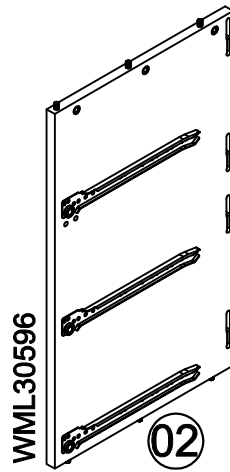

WML30596

02

1x

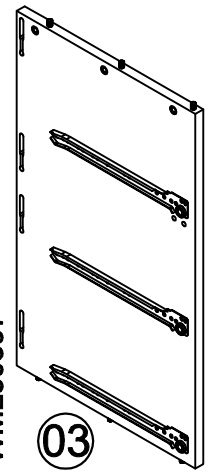

WML30597

03

1x

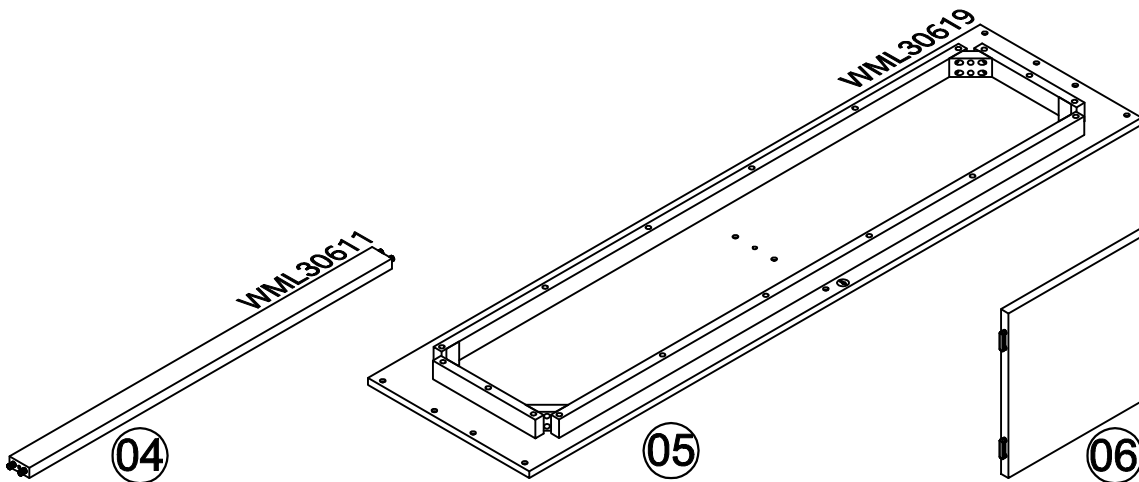

04

2x

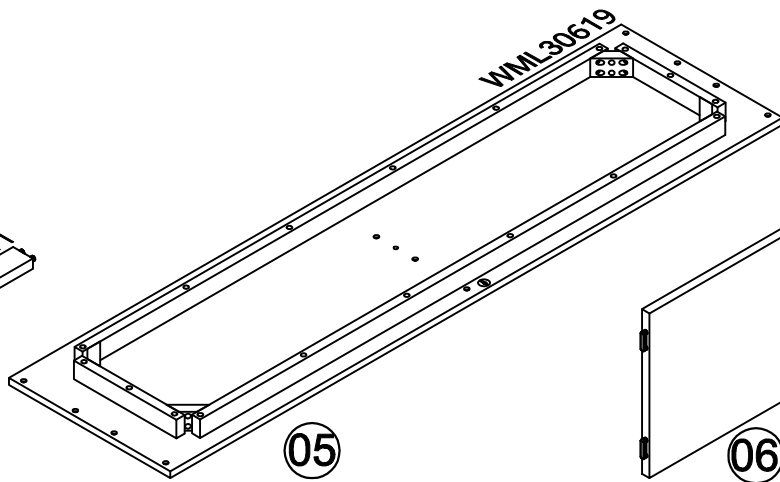

05

1x

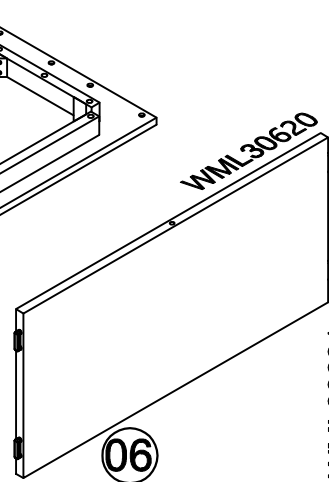

06

4x

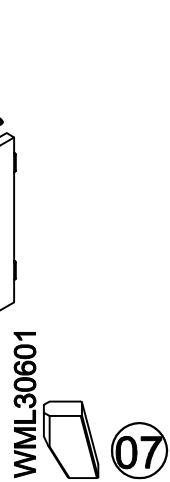

WML30601

07

4x

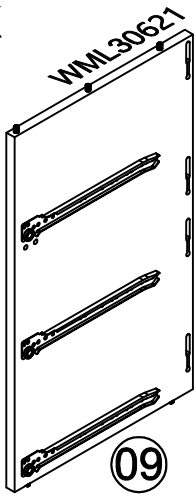

09

1x



WML30622

10

1x

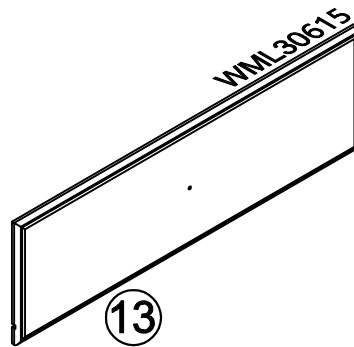

13

6x

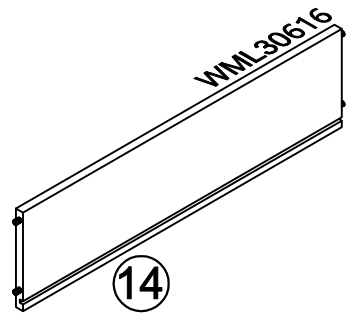

14

6x

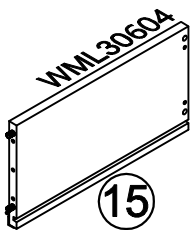

15

6x

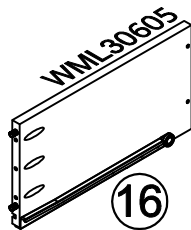

16

6x

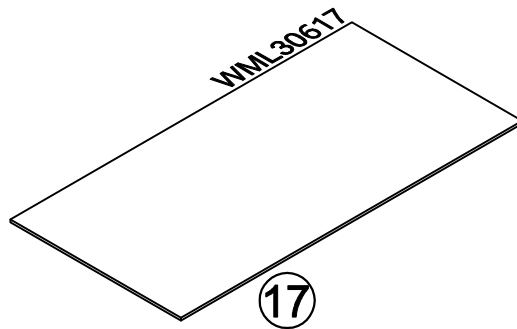

17

6x

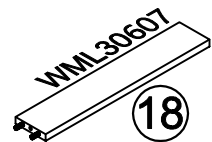

18

6x

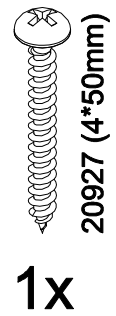
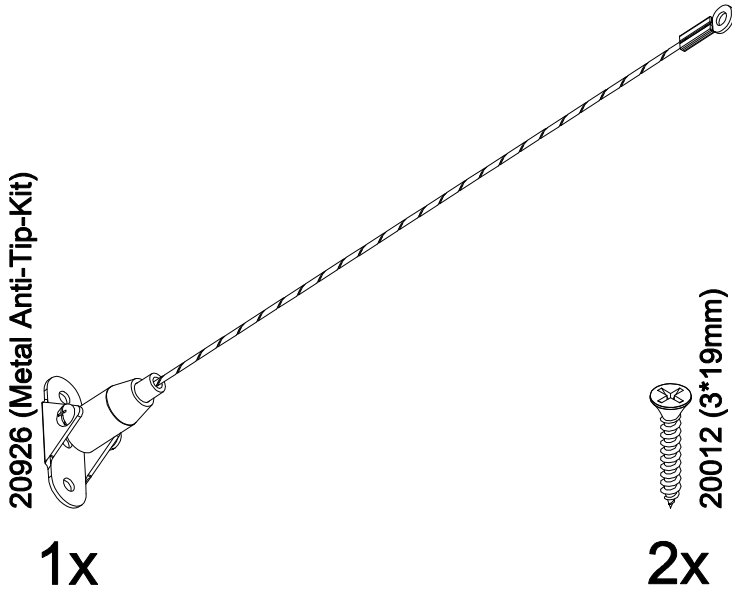
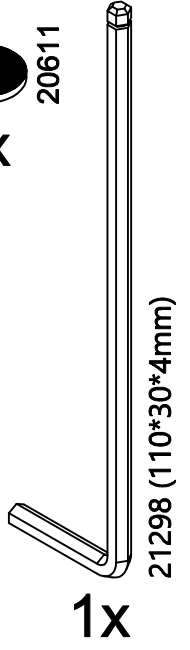
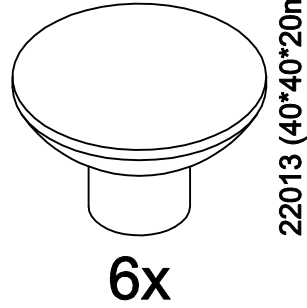
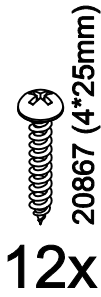
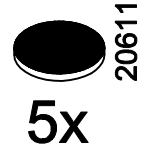
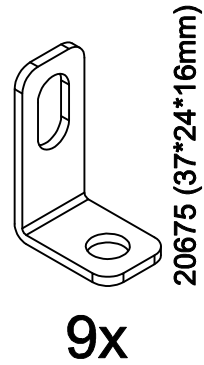
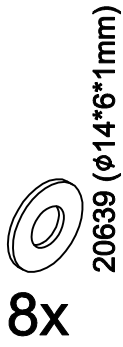
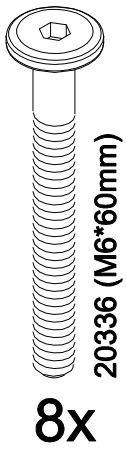

⚠ WARNING:

CHOKING HAZARD
Small Parts
Not for children under 3 years.
To be Assembled by an Adult

⚠ ATTENTION:

RISQUE D'ÉTOUFFEMENT
Petites parties
Ne convient pas aux enfants de moins de 3 ans.
Doit être assemblé par un adulte

⚠ ADVERTENCIA

PELIGRO DE ASFIXIA
Partes pequeñas
No apta para niños menores de 3 años
A ser ensamblado por un adulto

Not Included
Non Inclus
No Incluido

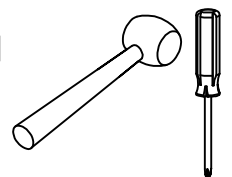

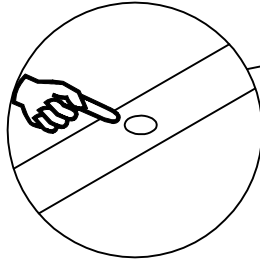
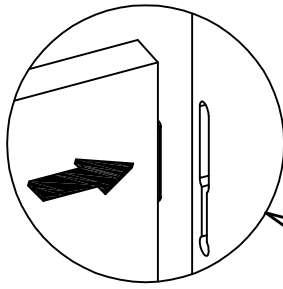
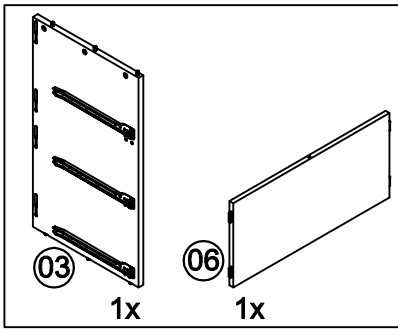

06

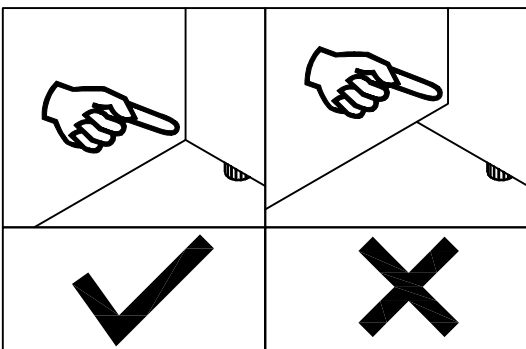
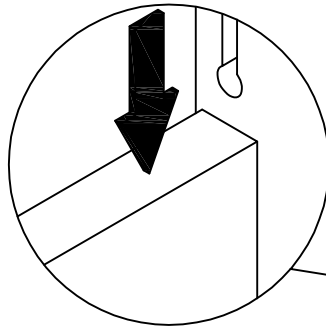
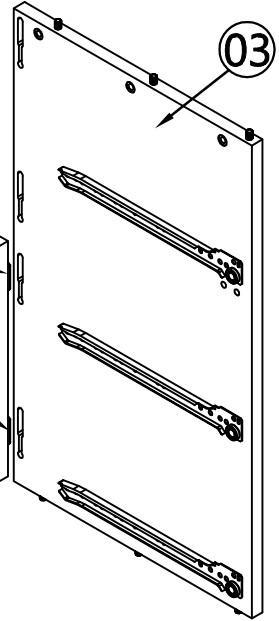

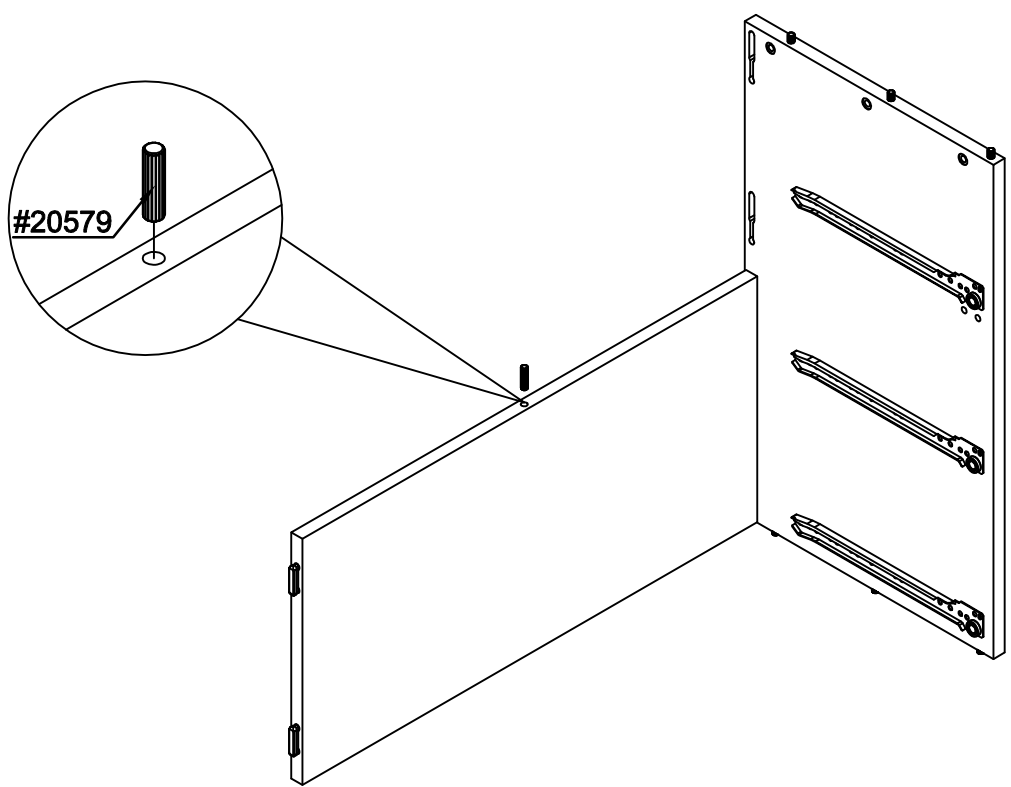

#20579

20579 (ø8*30mm)
1x

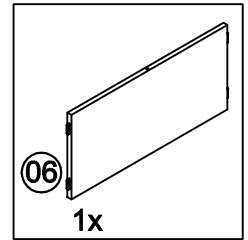
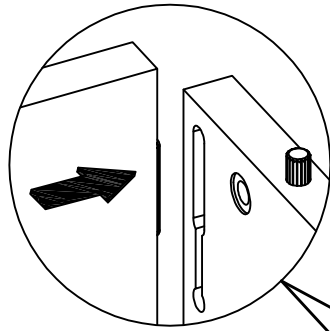

06

1x

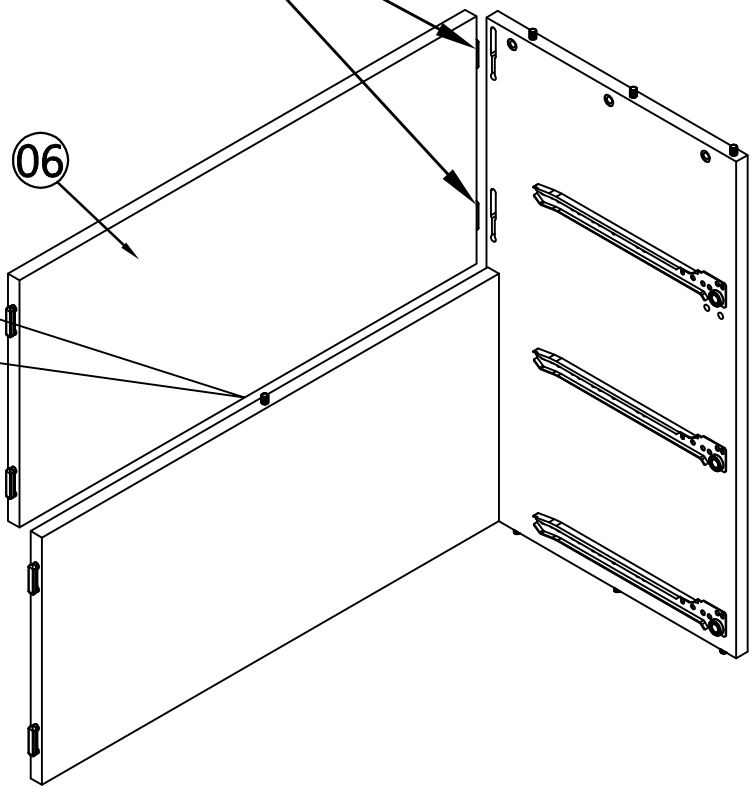
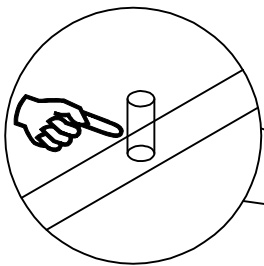

06

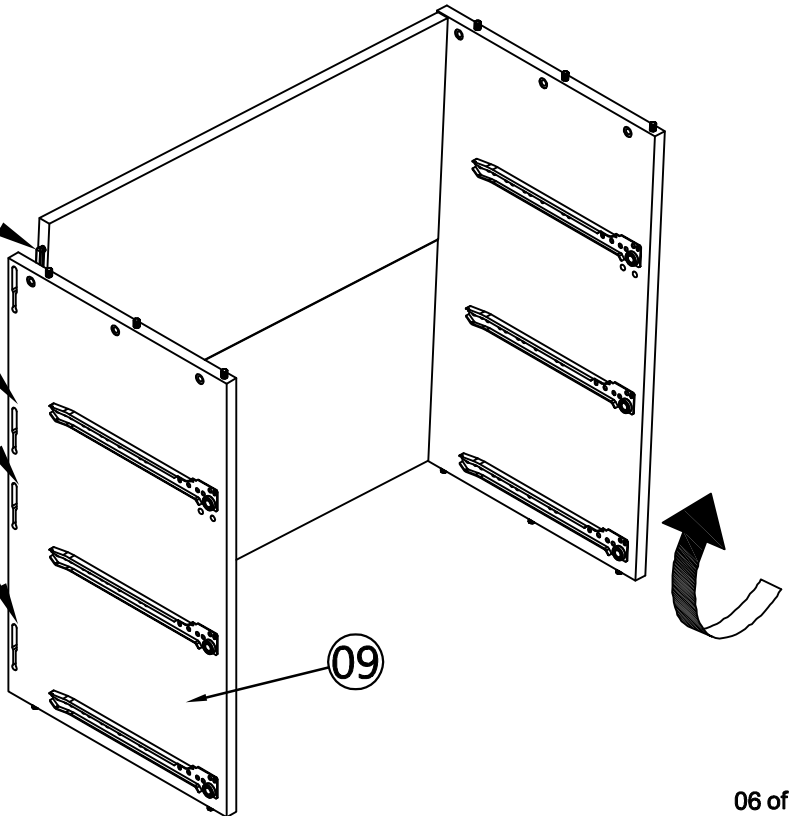
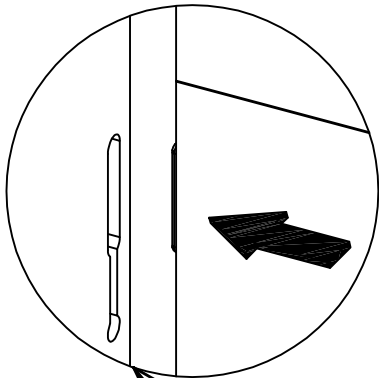
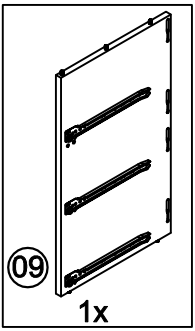
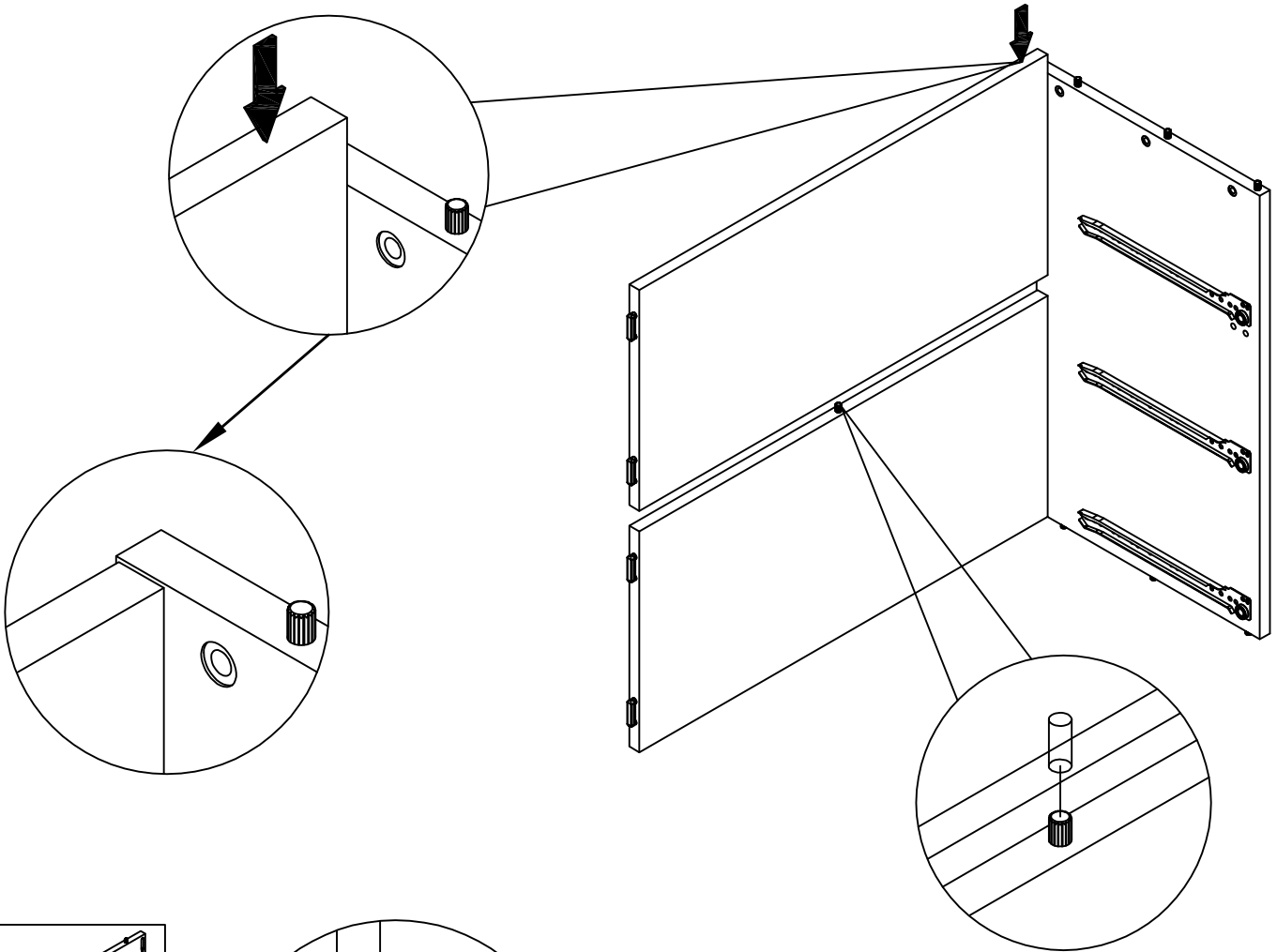

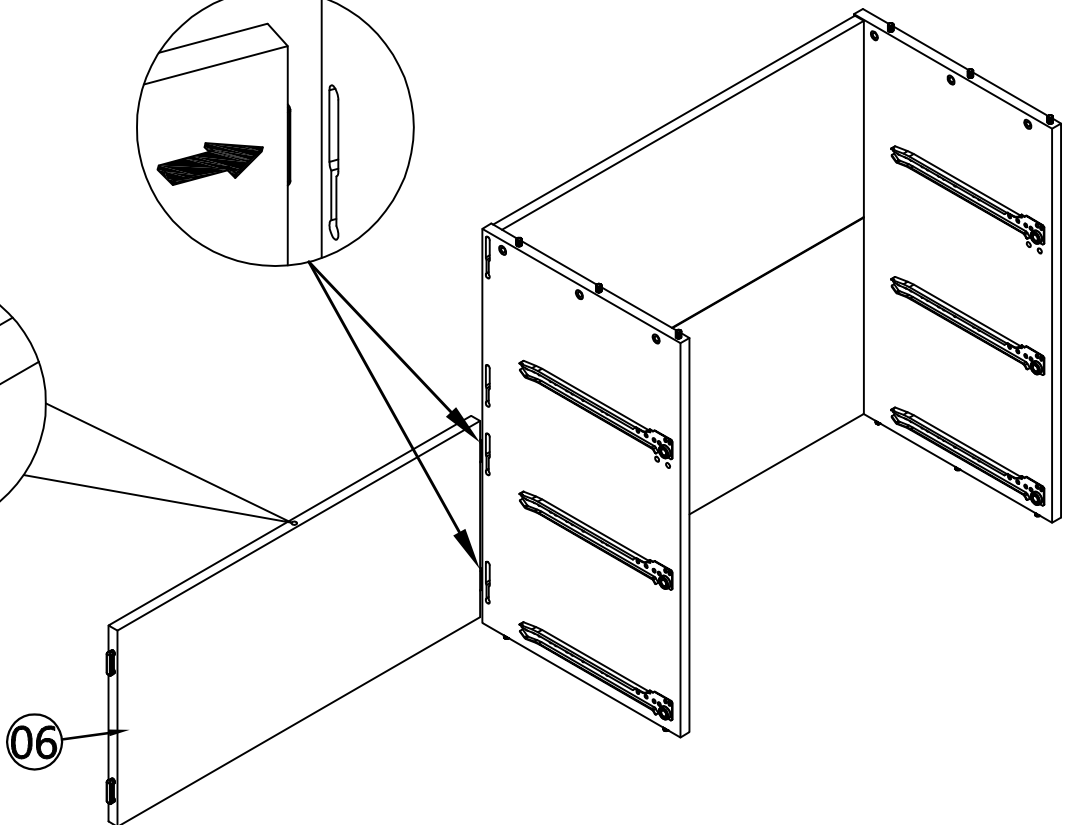
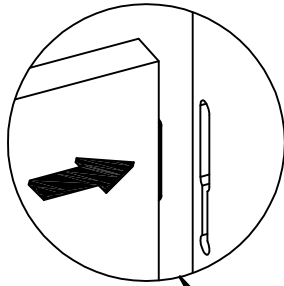
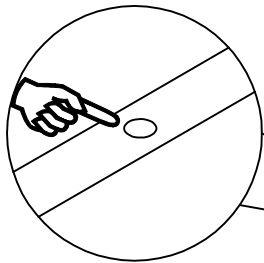
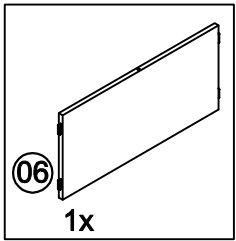
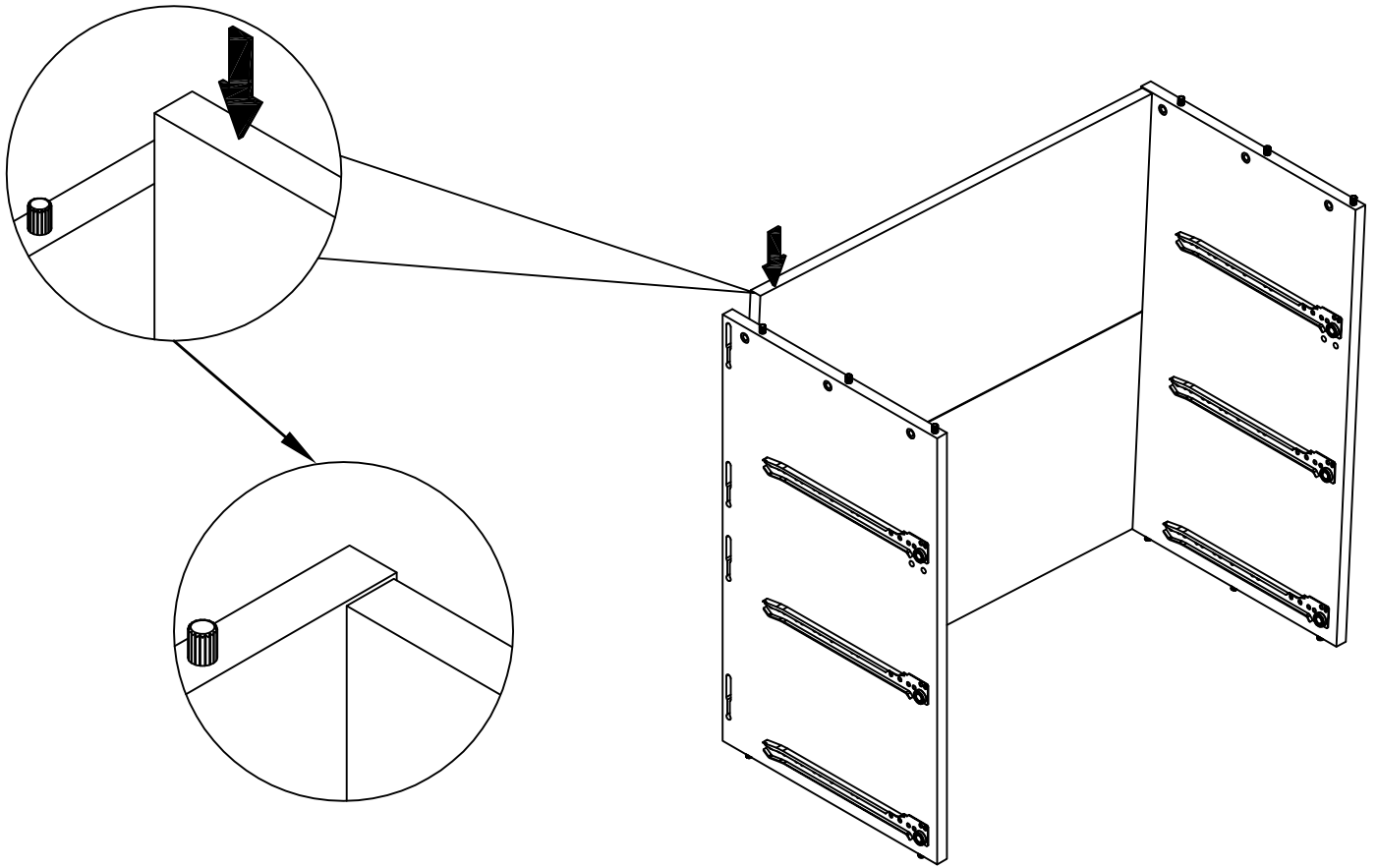

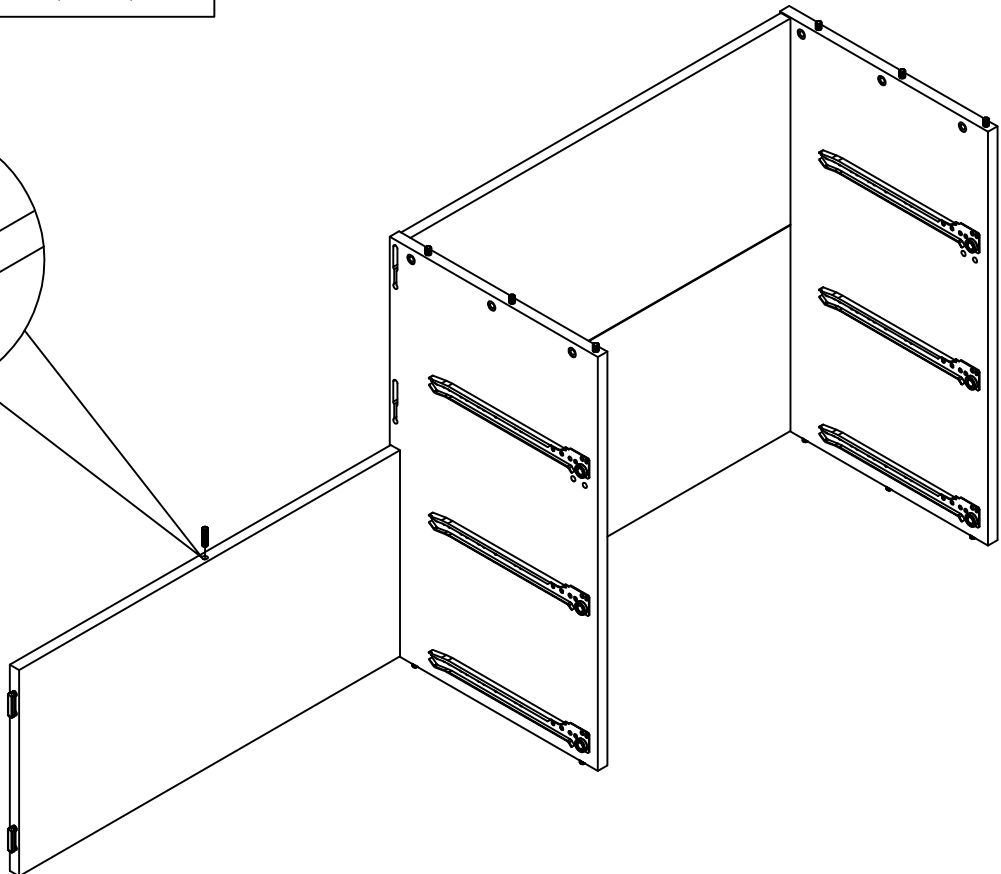
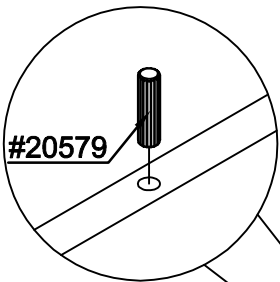
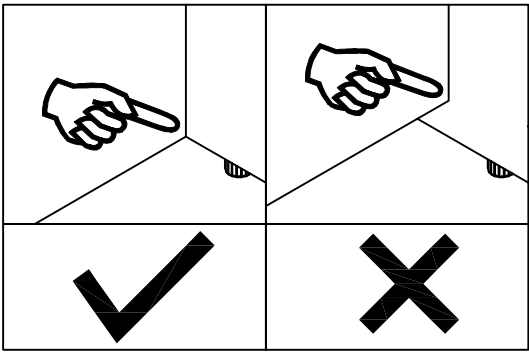
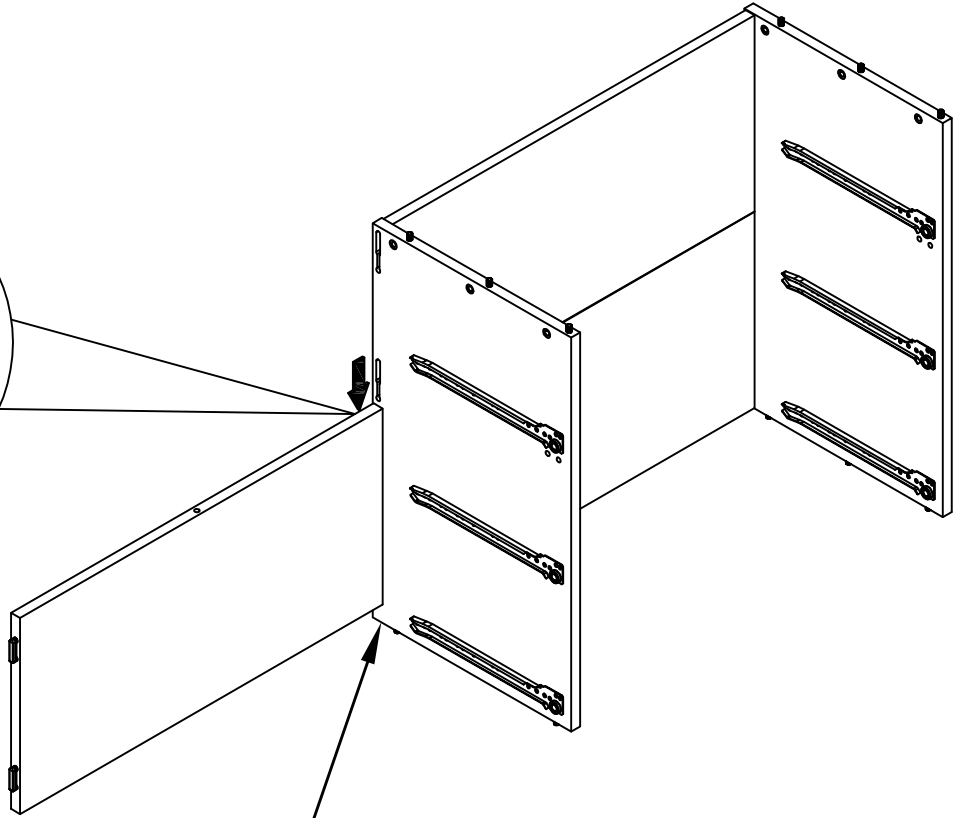
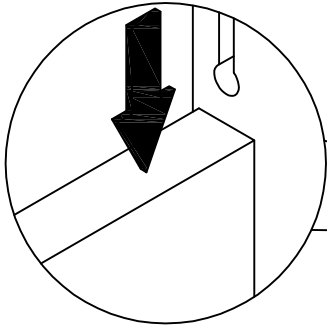

20579 (ø8*30mm)

1x

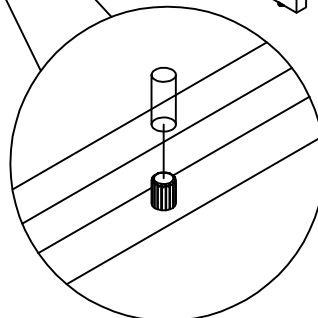
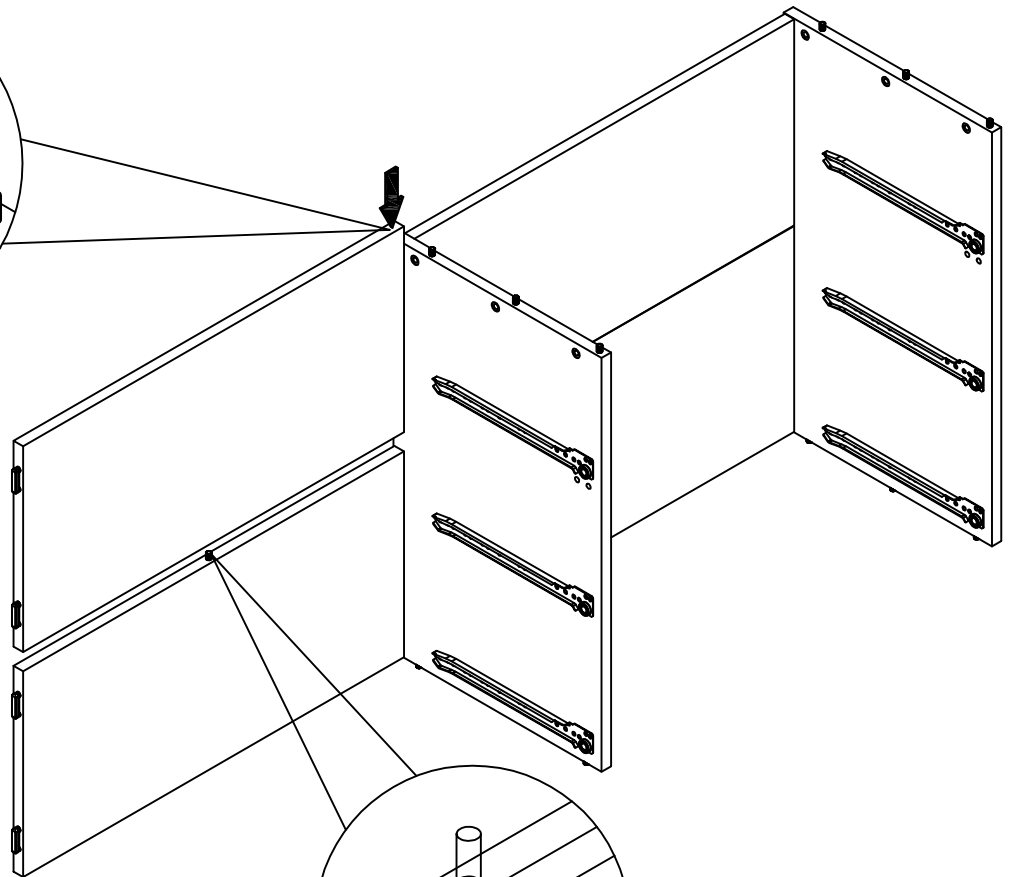
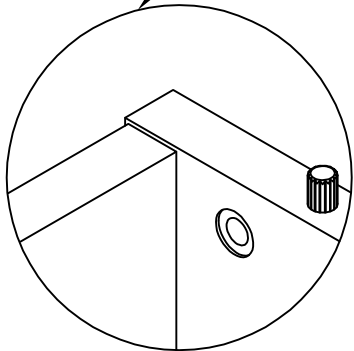
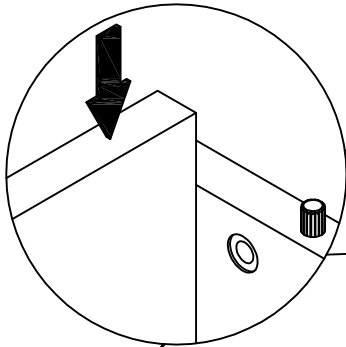
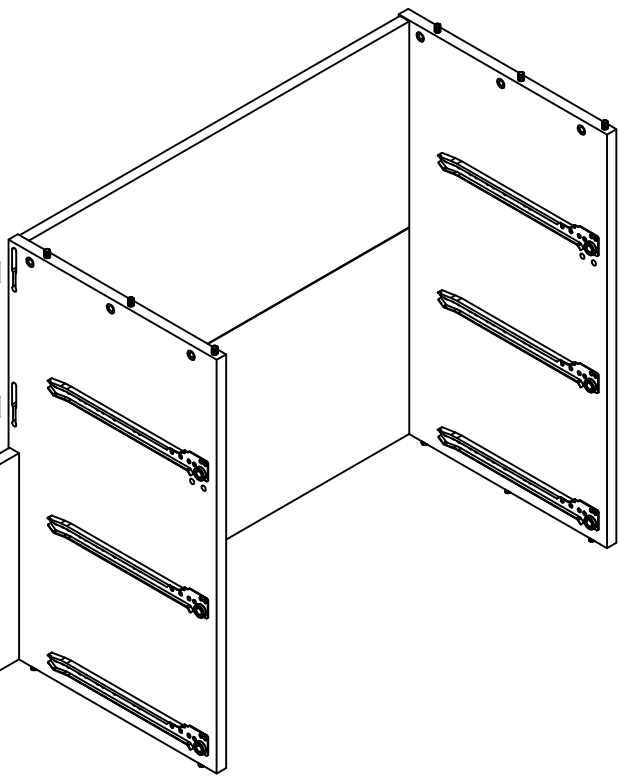
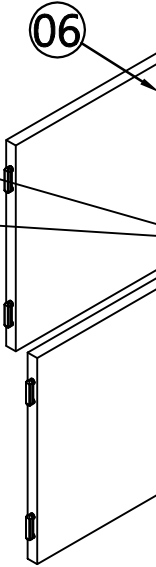
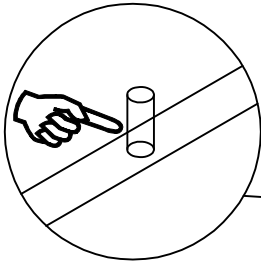
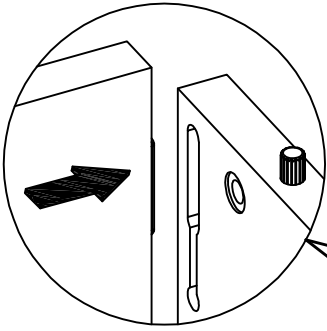
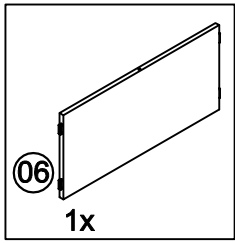

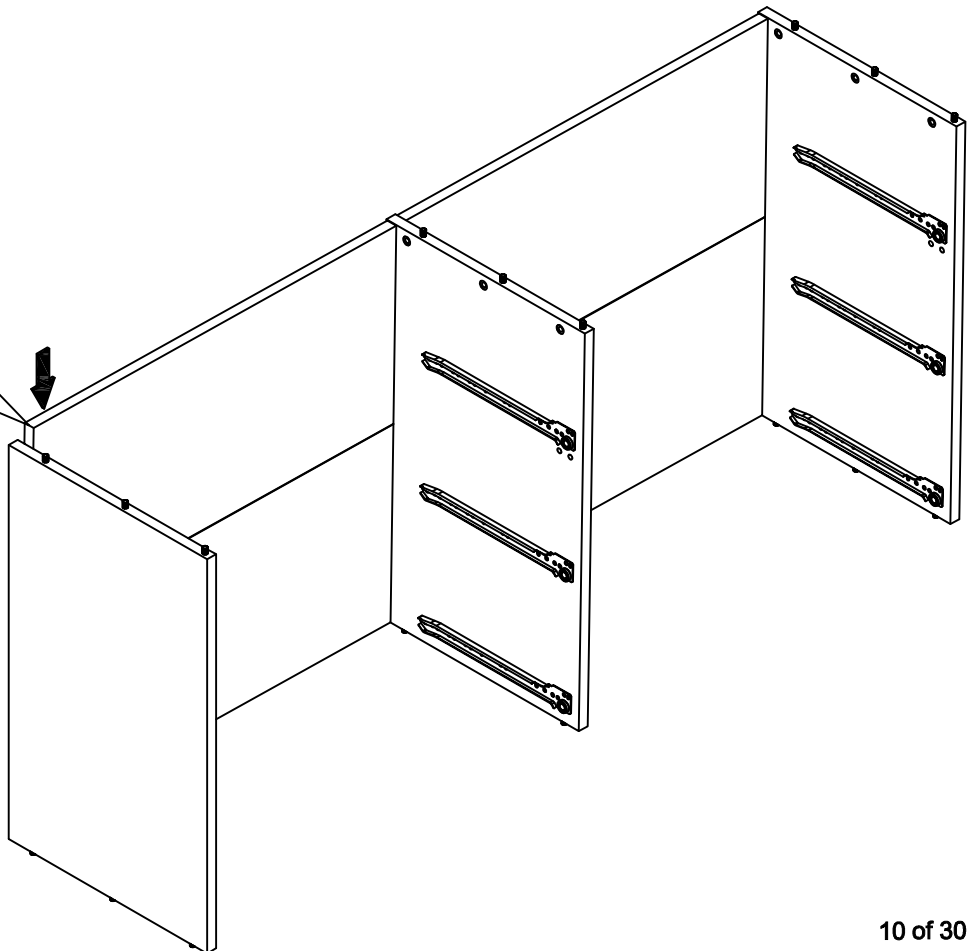
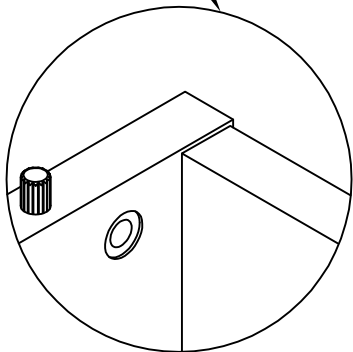
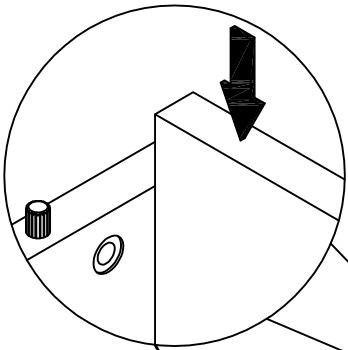
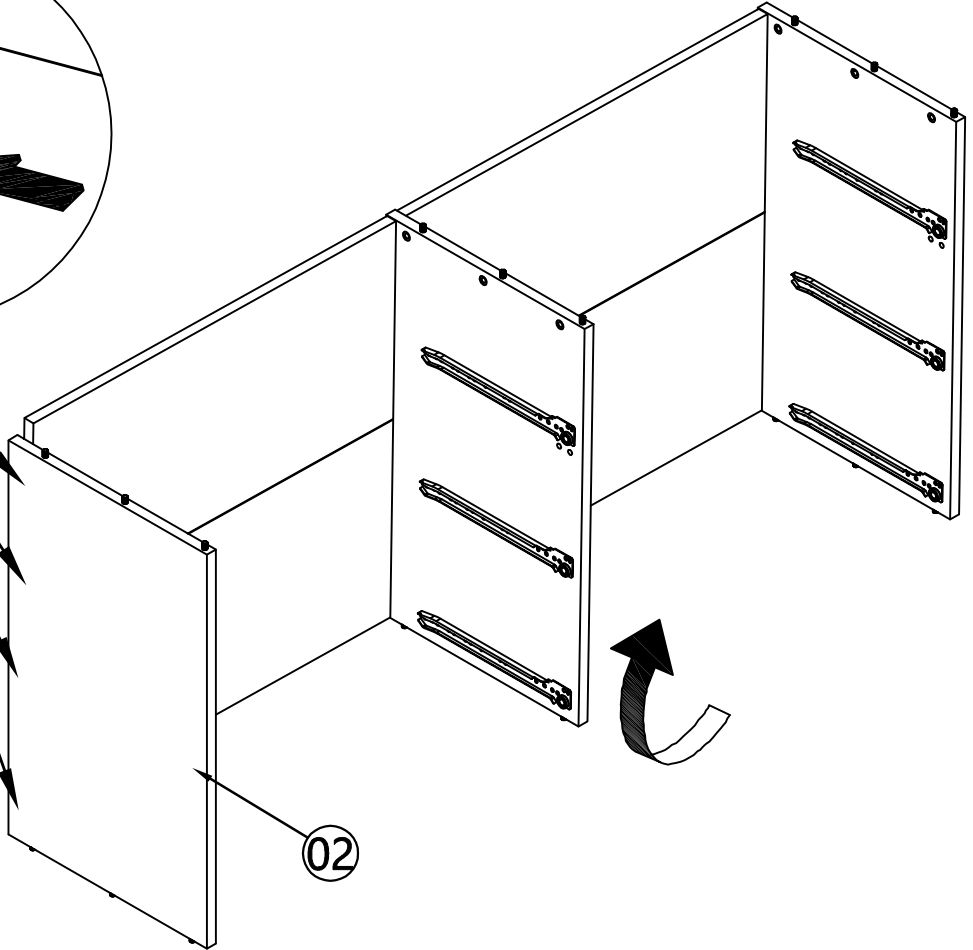
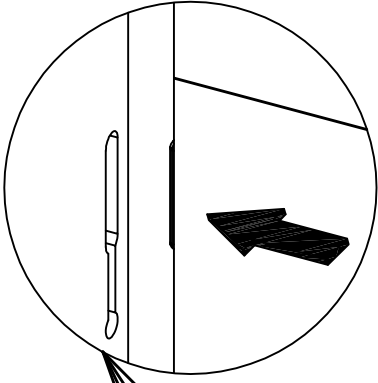
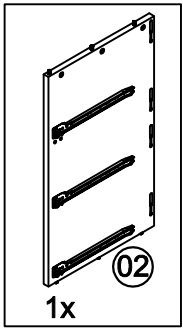

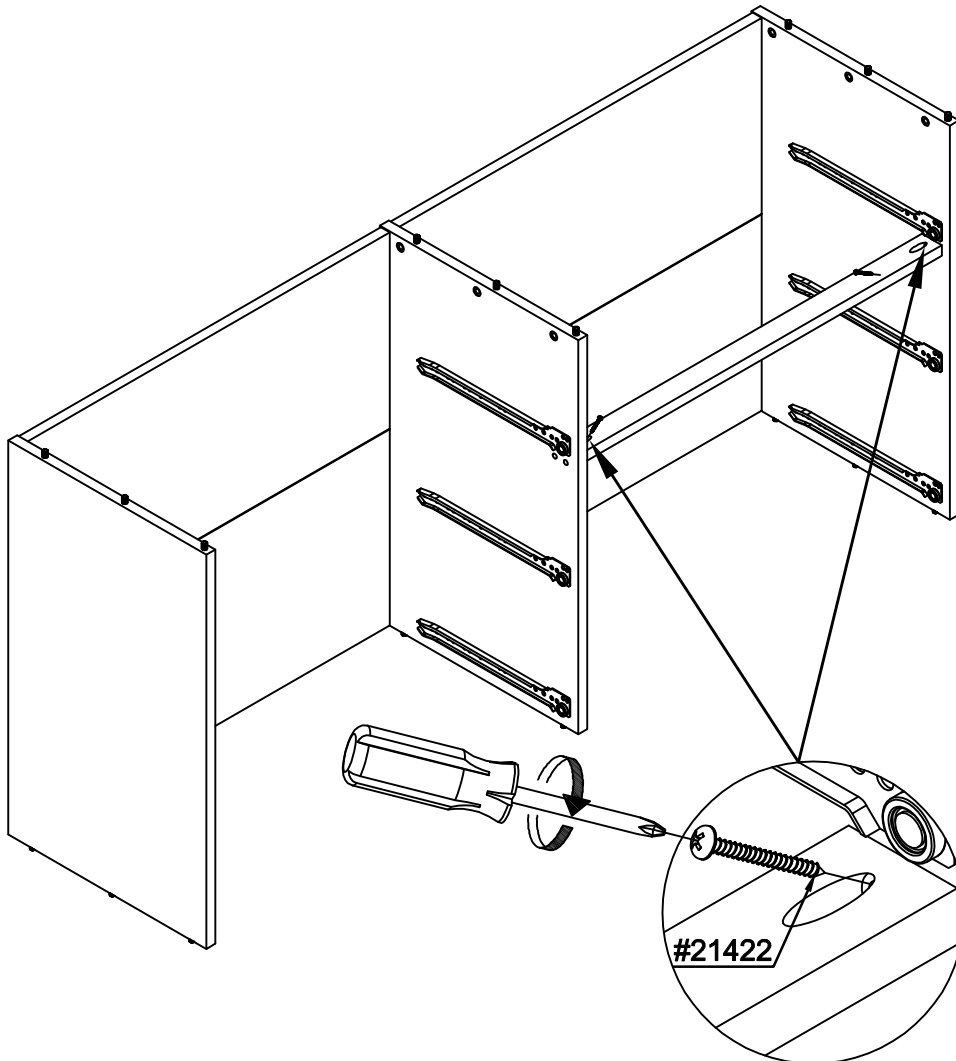
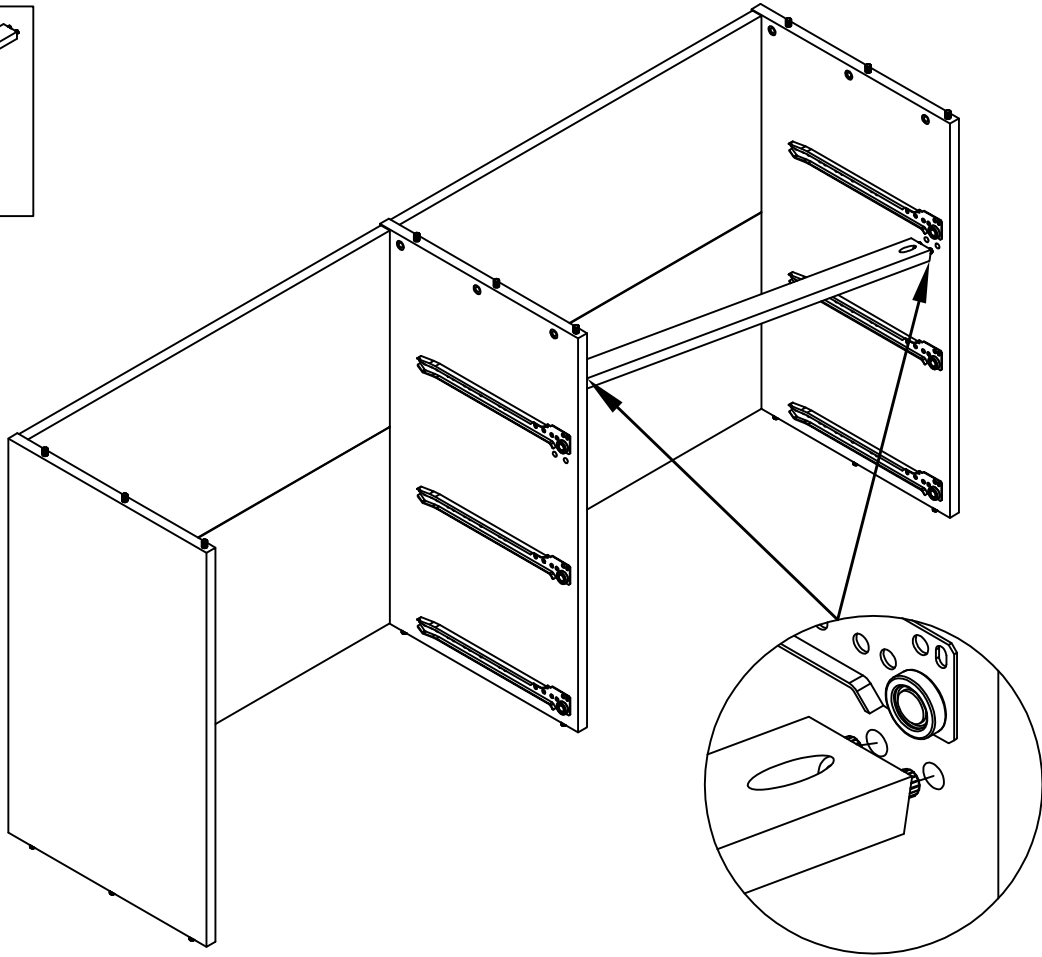
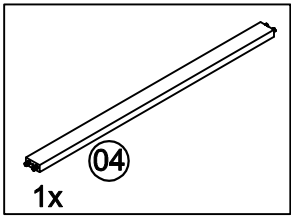

2x
21422 (4*30mm)

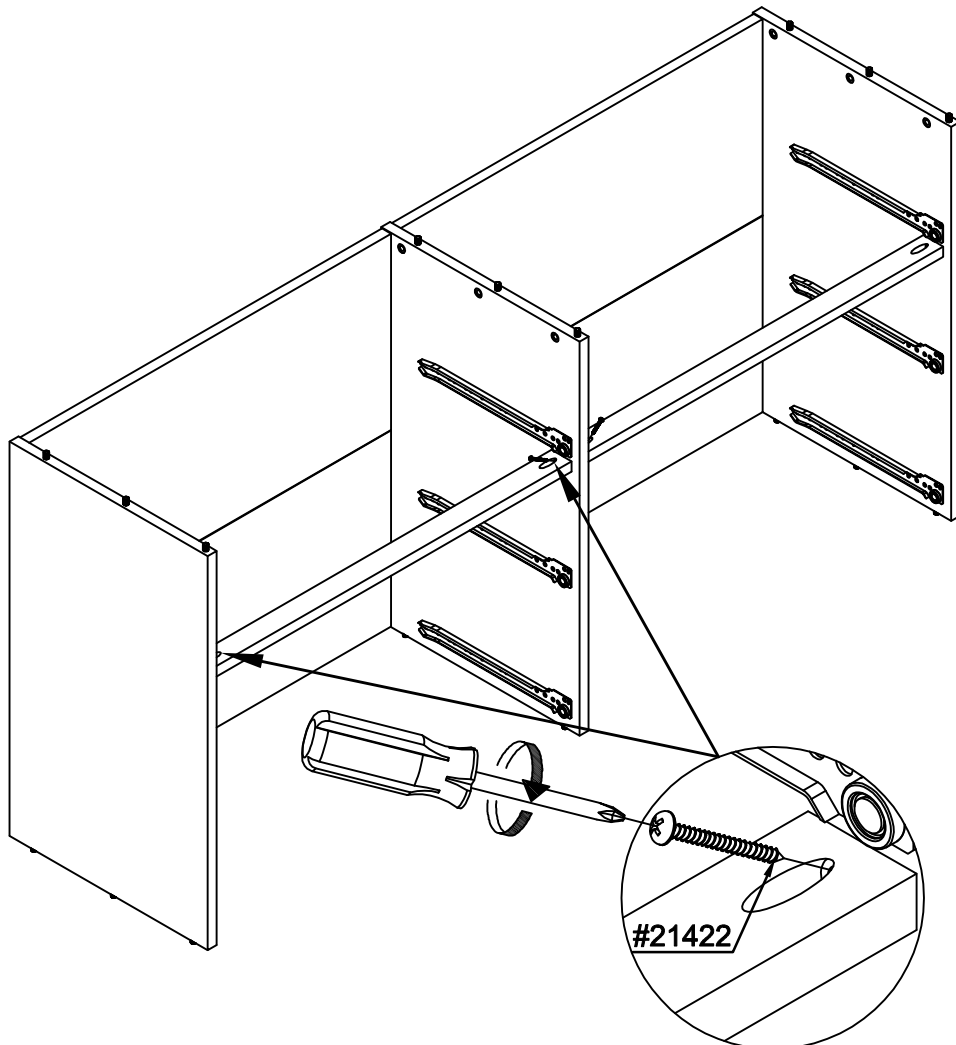
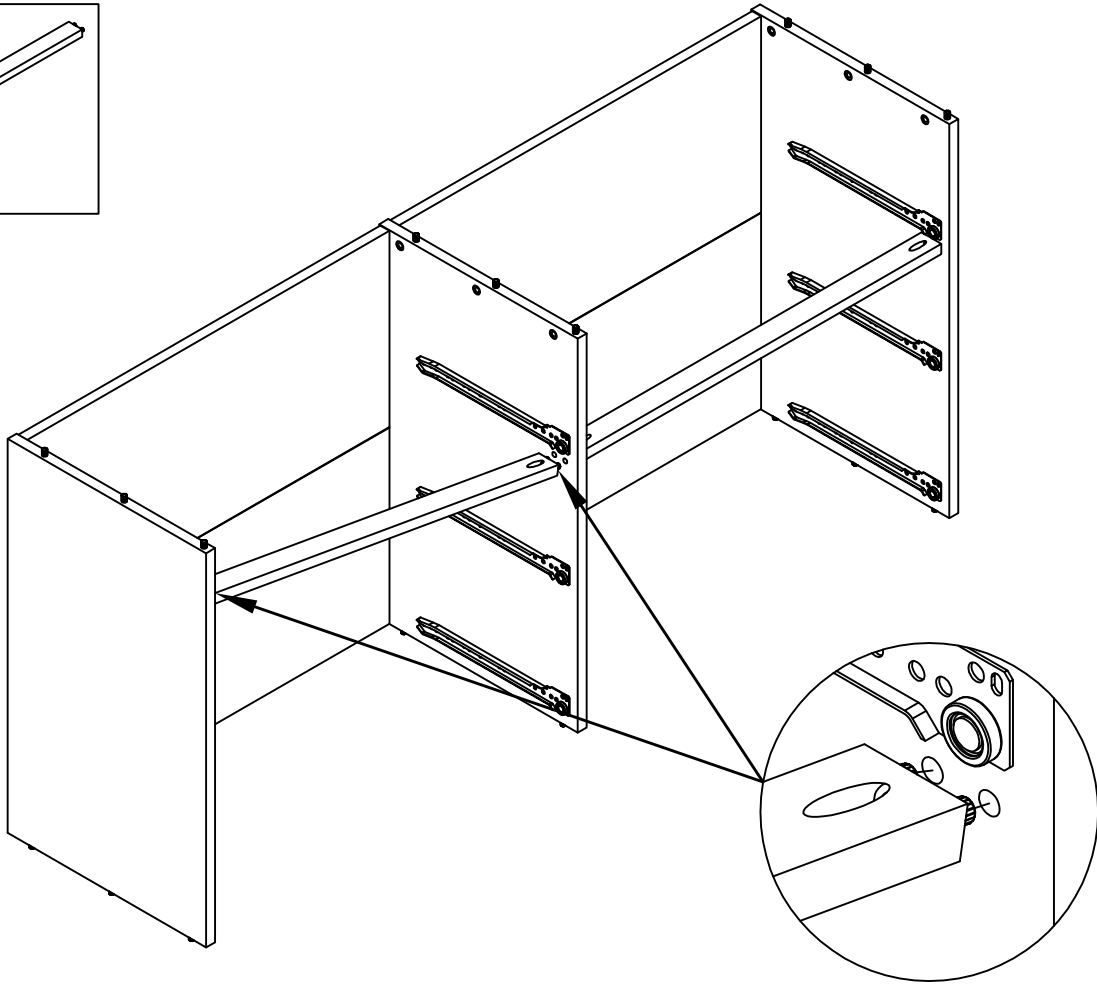
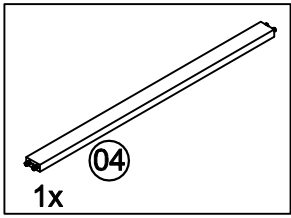

2x  21422 (4*30mm)

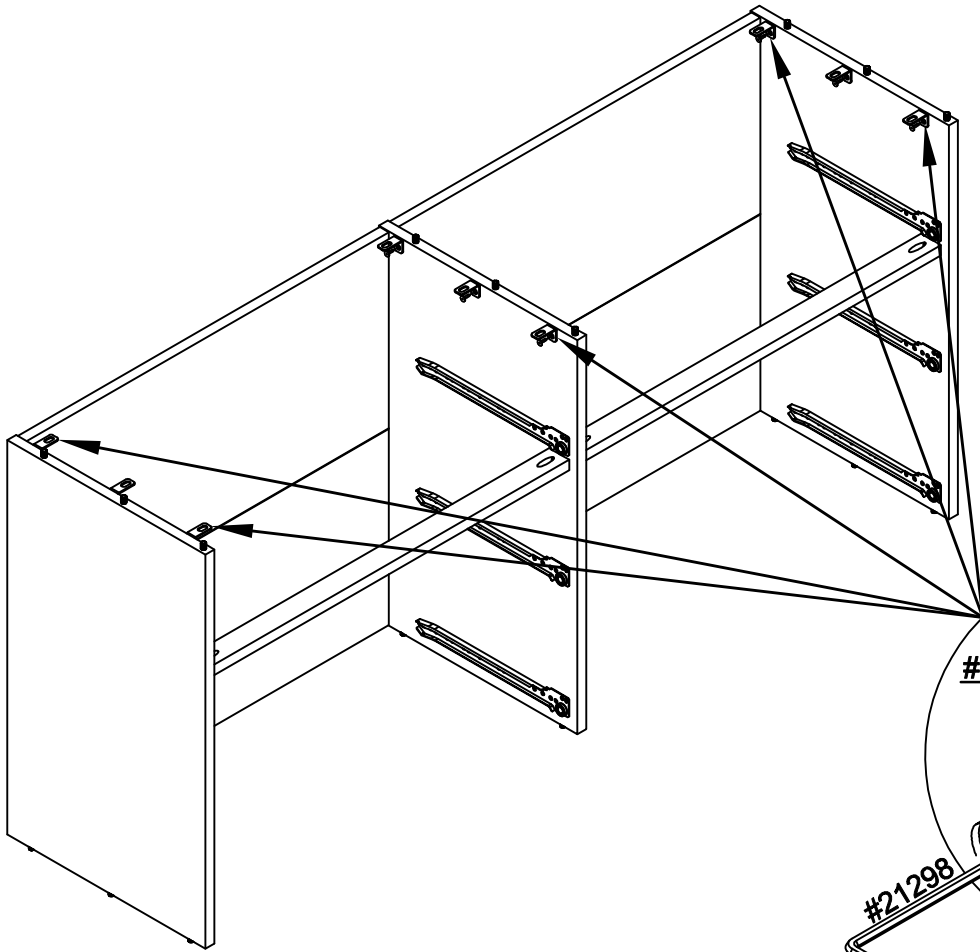

- 9x 20677 (M6*15mm)
- 9x 20675 (37*24*16mm)

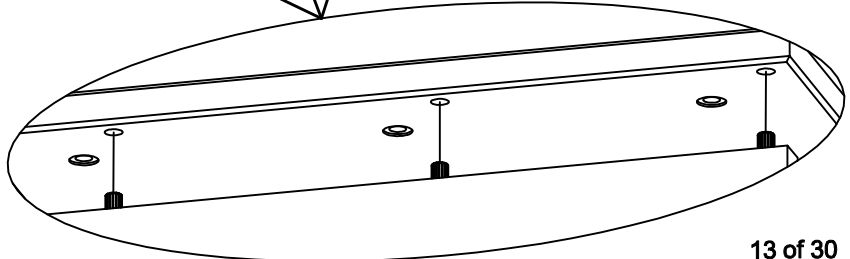
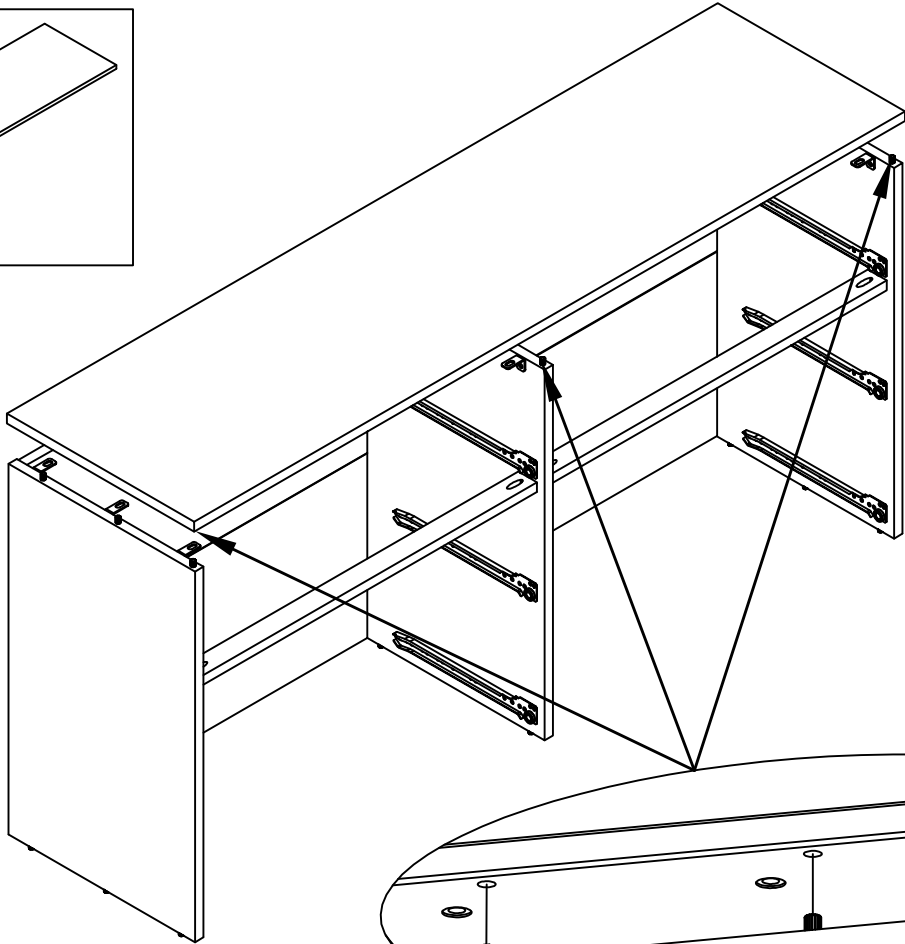
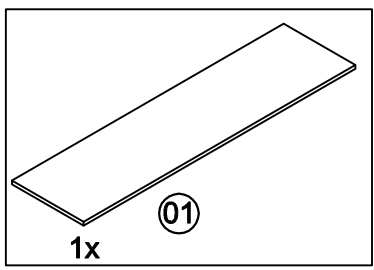
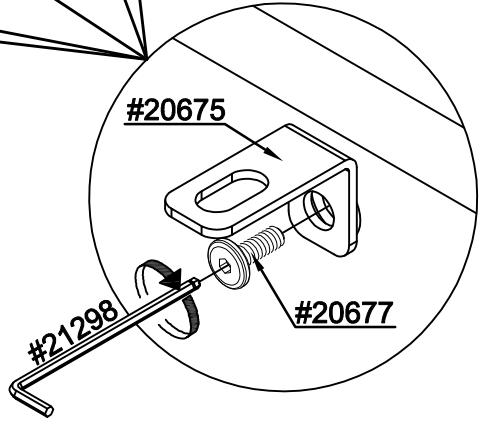

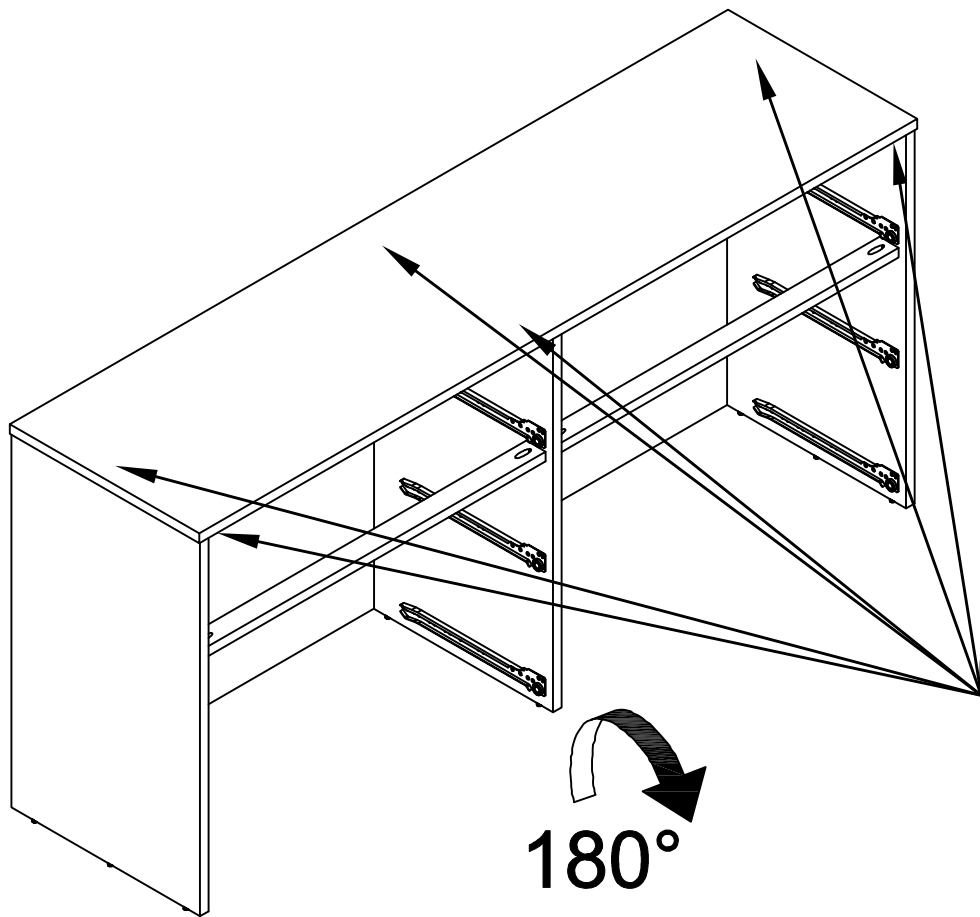

9x
#20677 (M6*15mm)

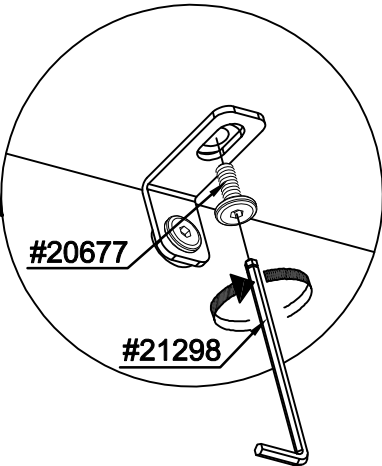

180°

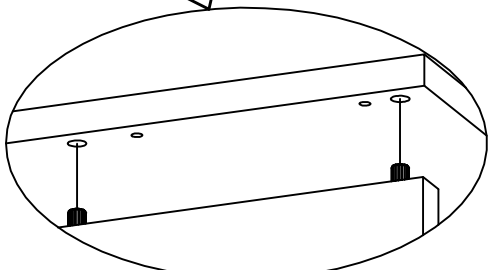
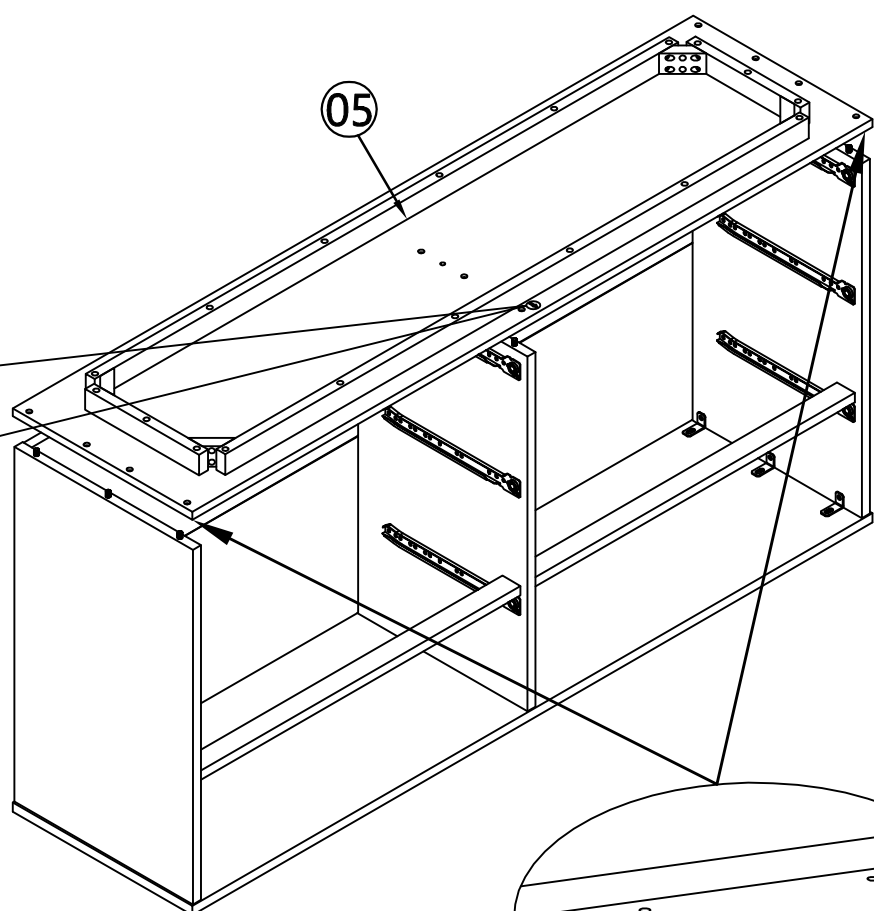
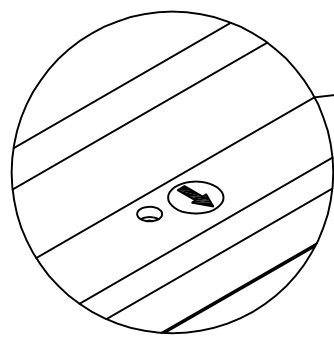
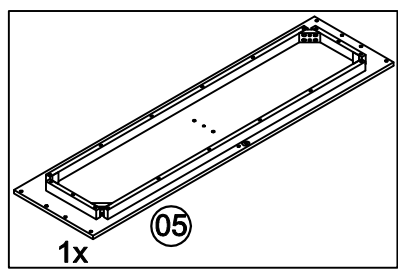

12x
21422 (4*30mm)

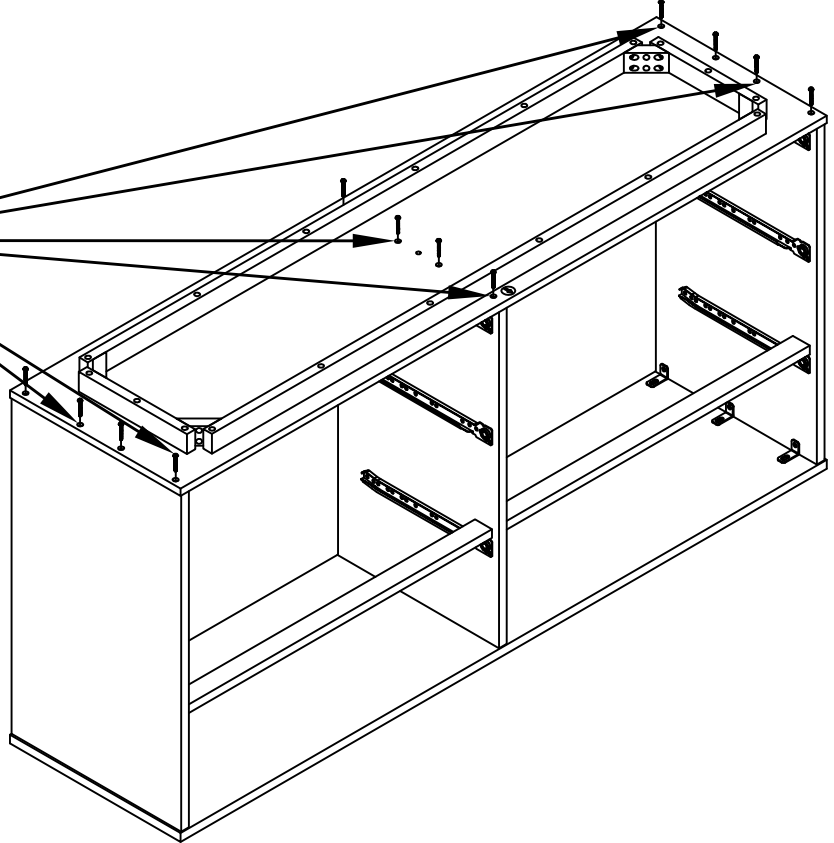
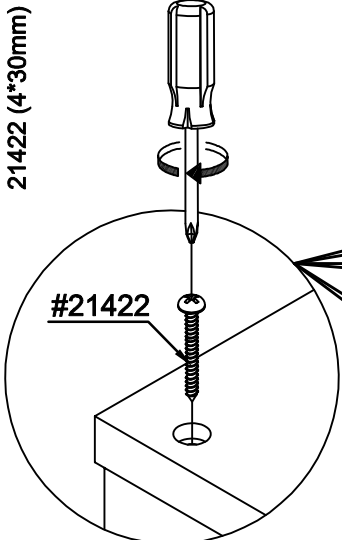

8x
20336 (M6*60mm)

8x
20639 (φ14*6*1mm)

8x
20129 (φ12*6*2mm)

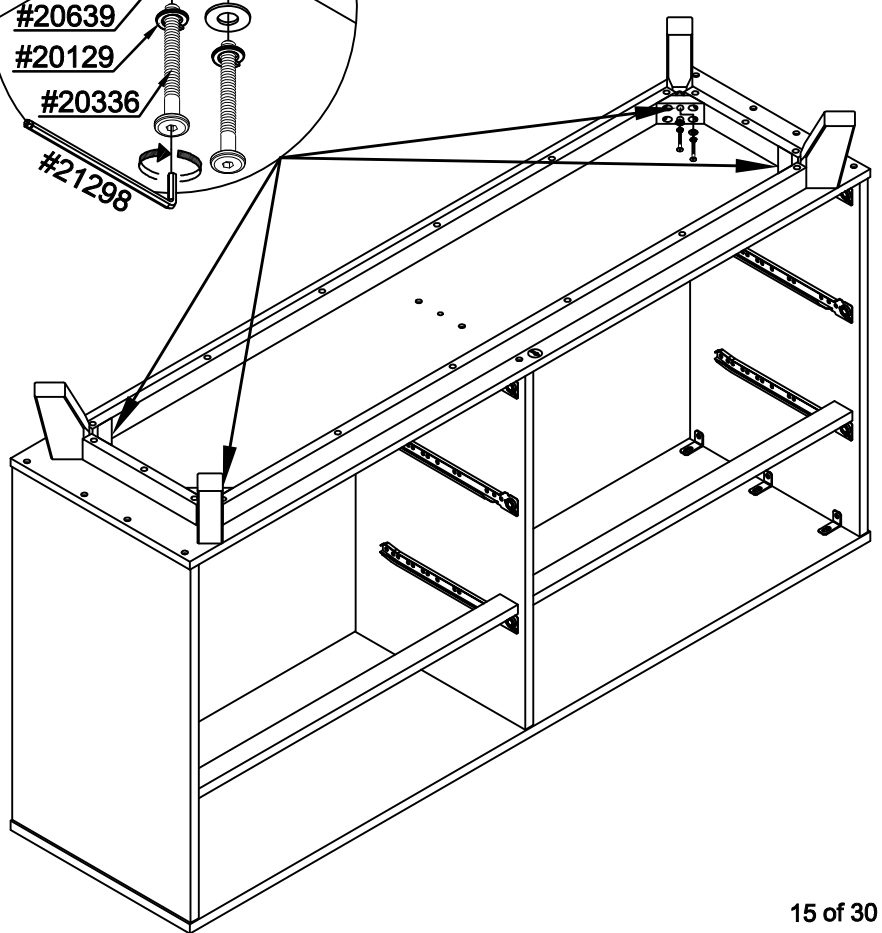
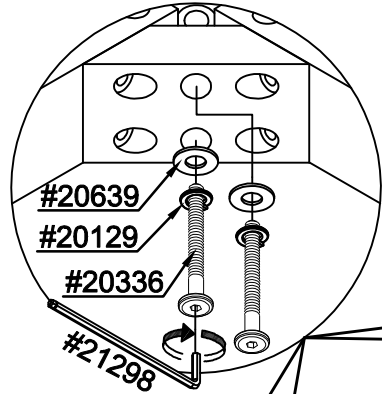
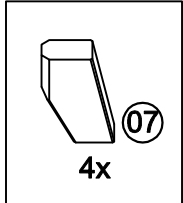

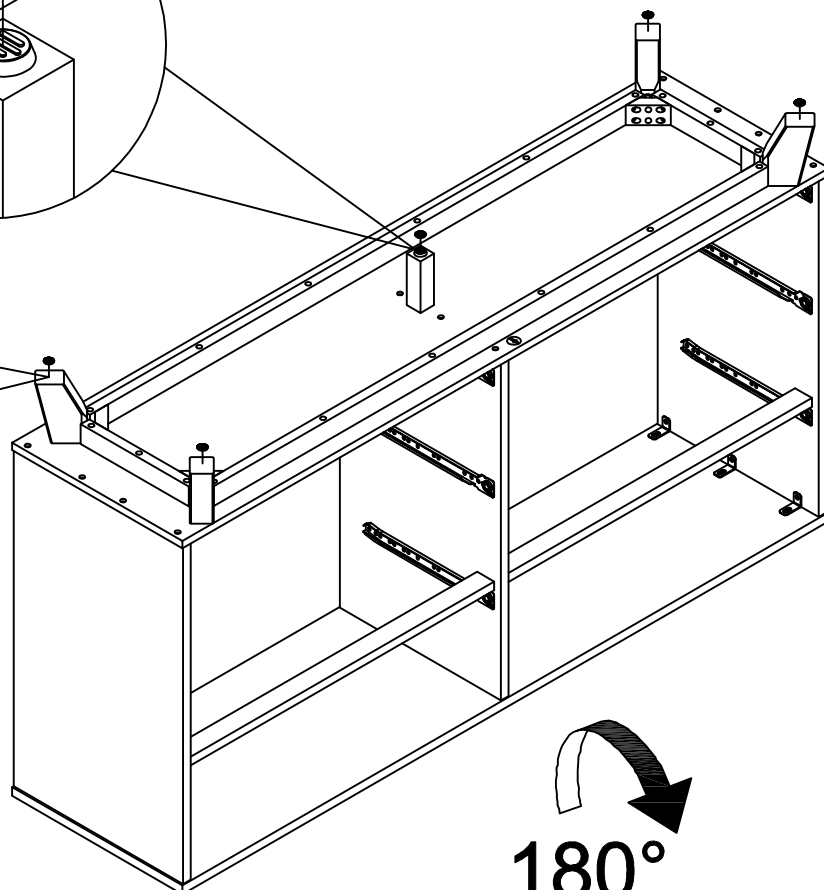
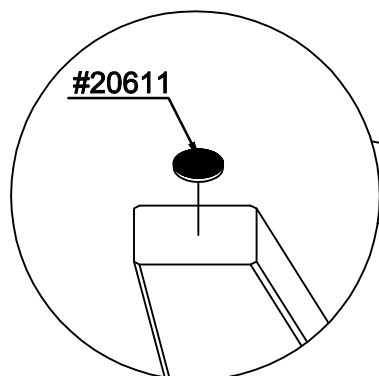
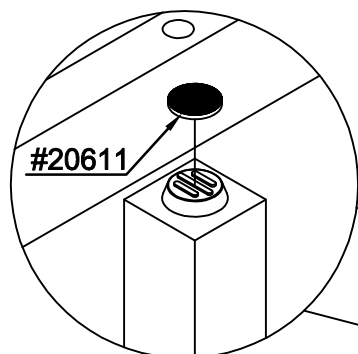
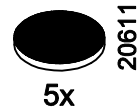
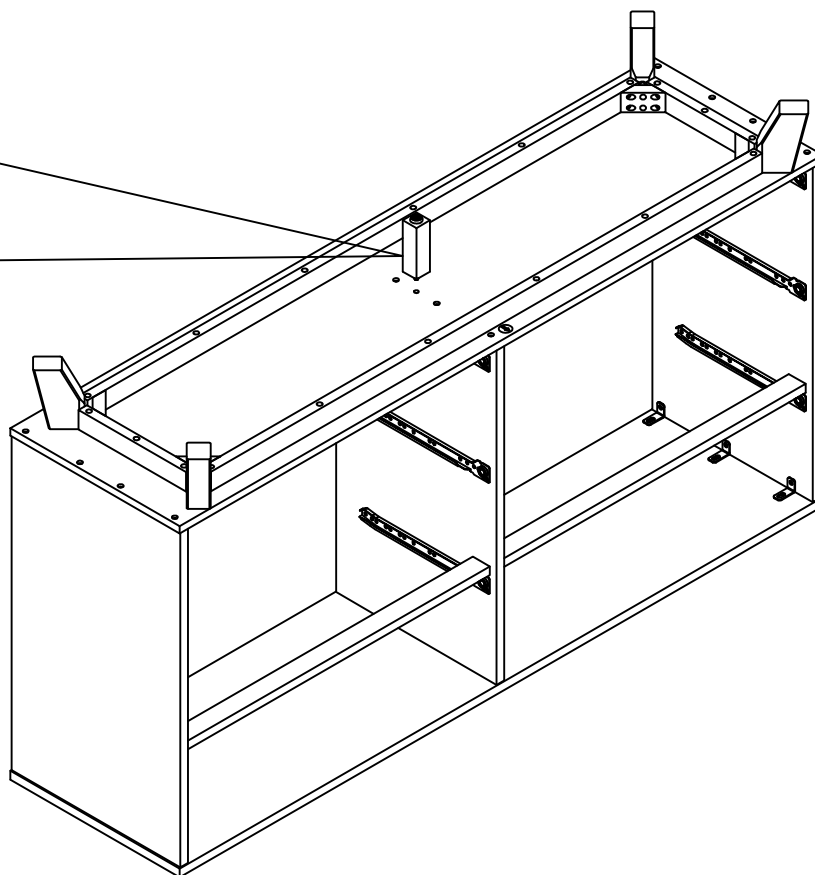
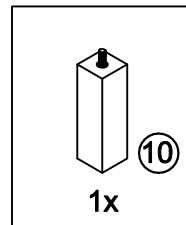
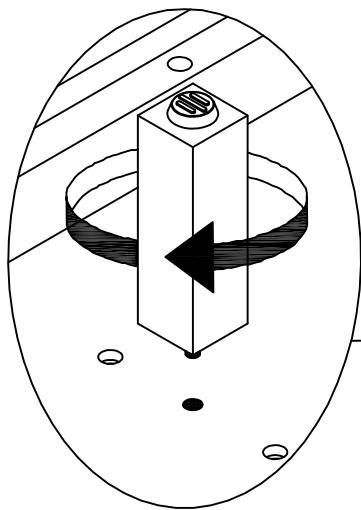

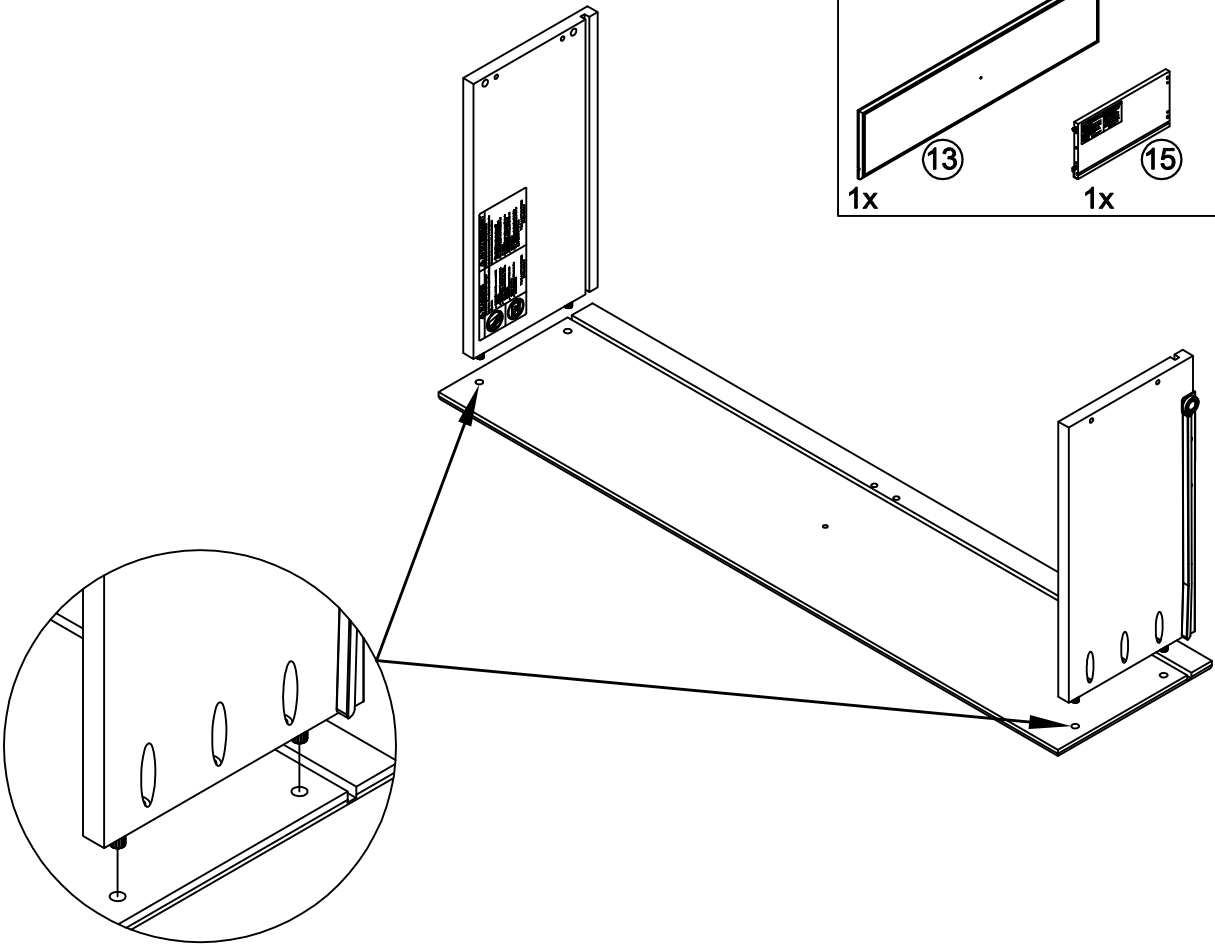
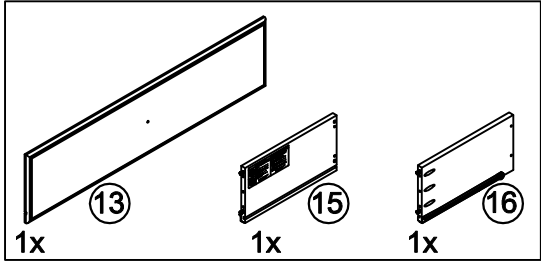

6x 21422 (4*30mm)



The text indicates that six screws of type 21422 (4*30mm) are required for this step. A small icon of a screw is shown to the left of the text.

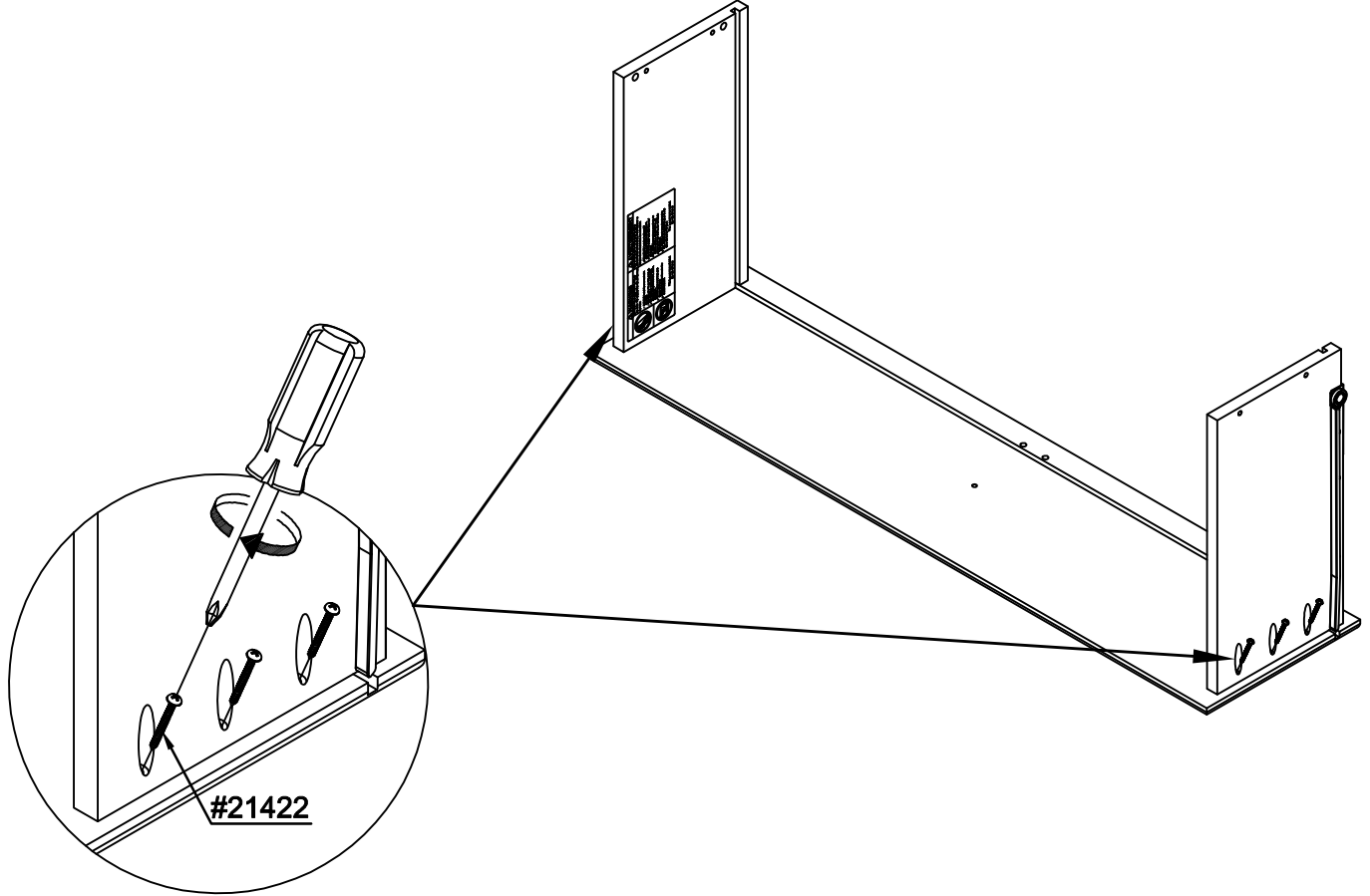

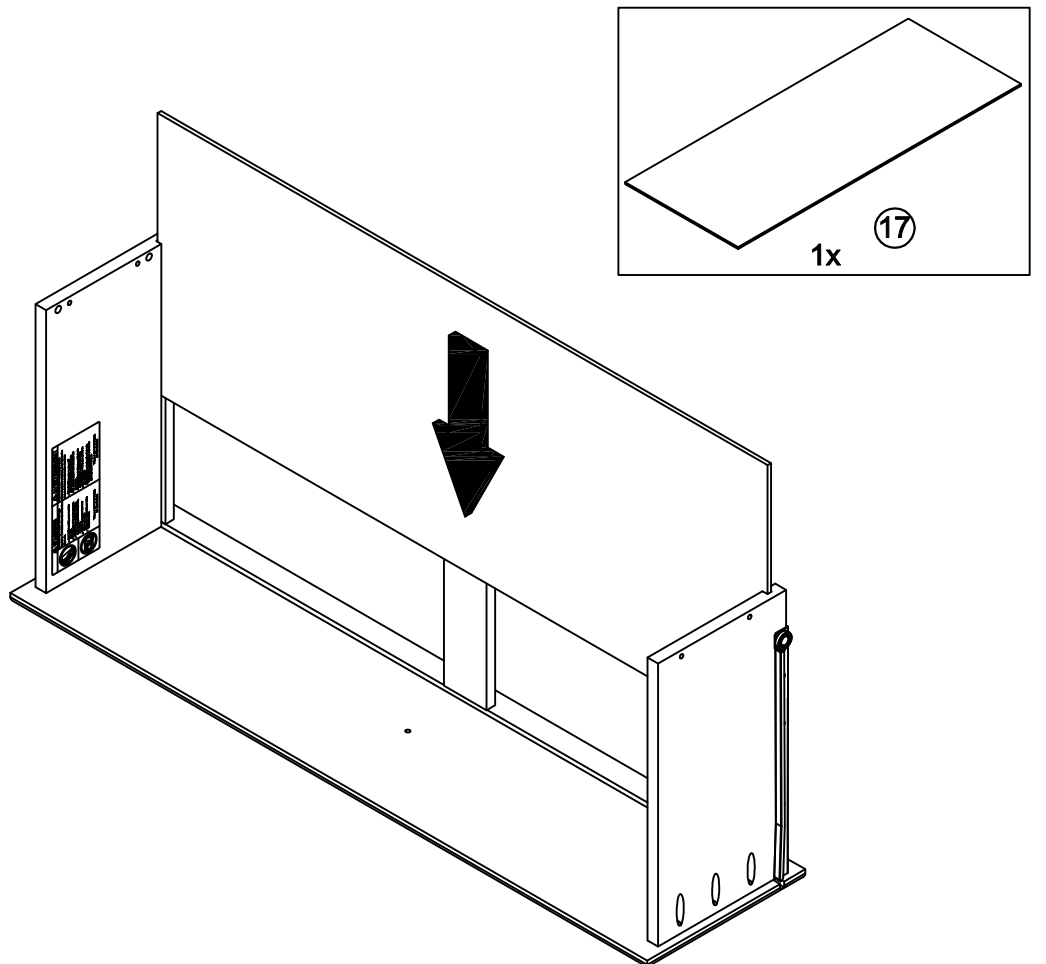
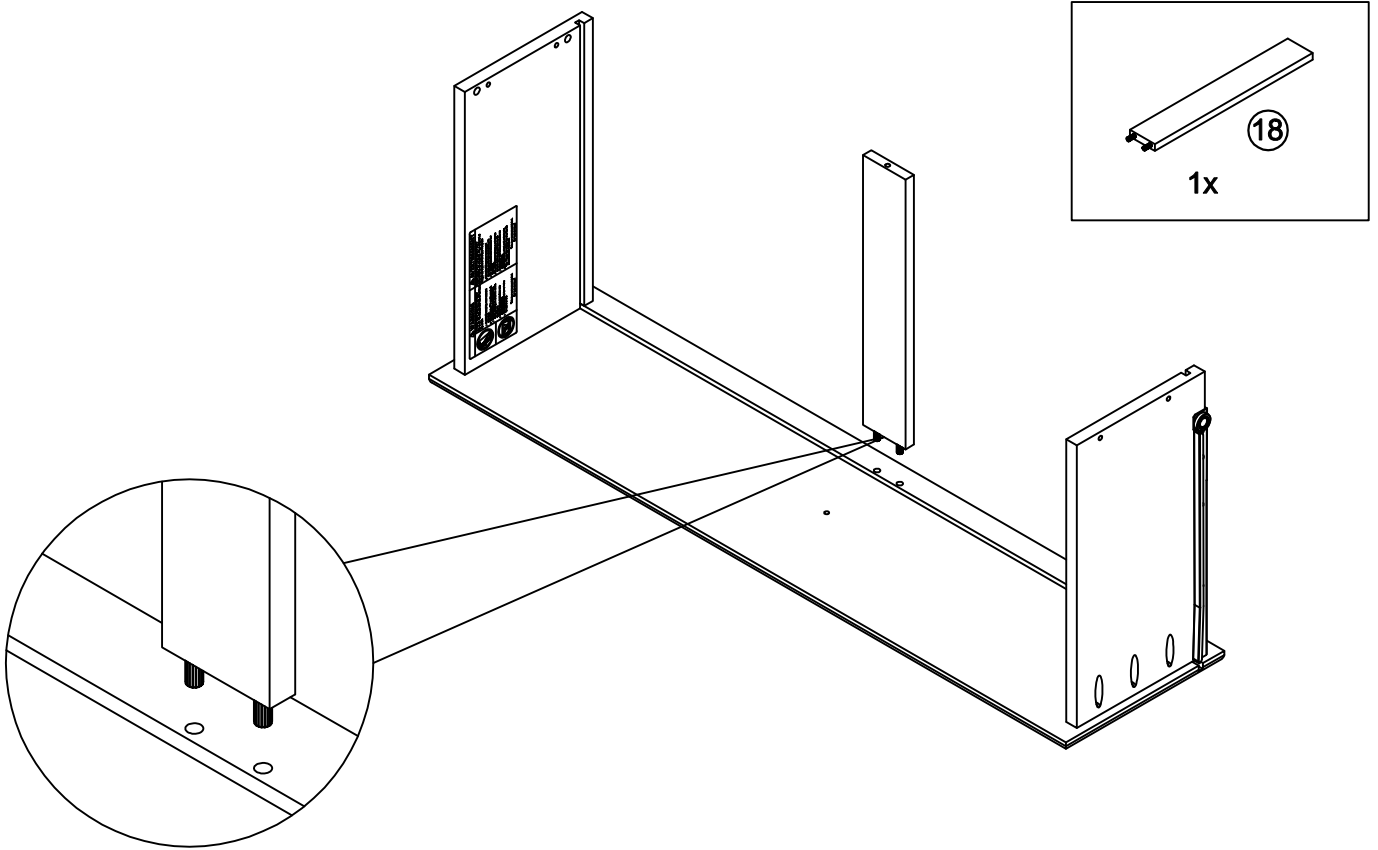

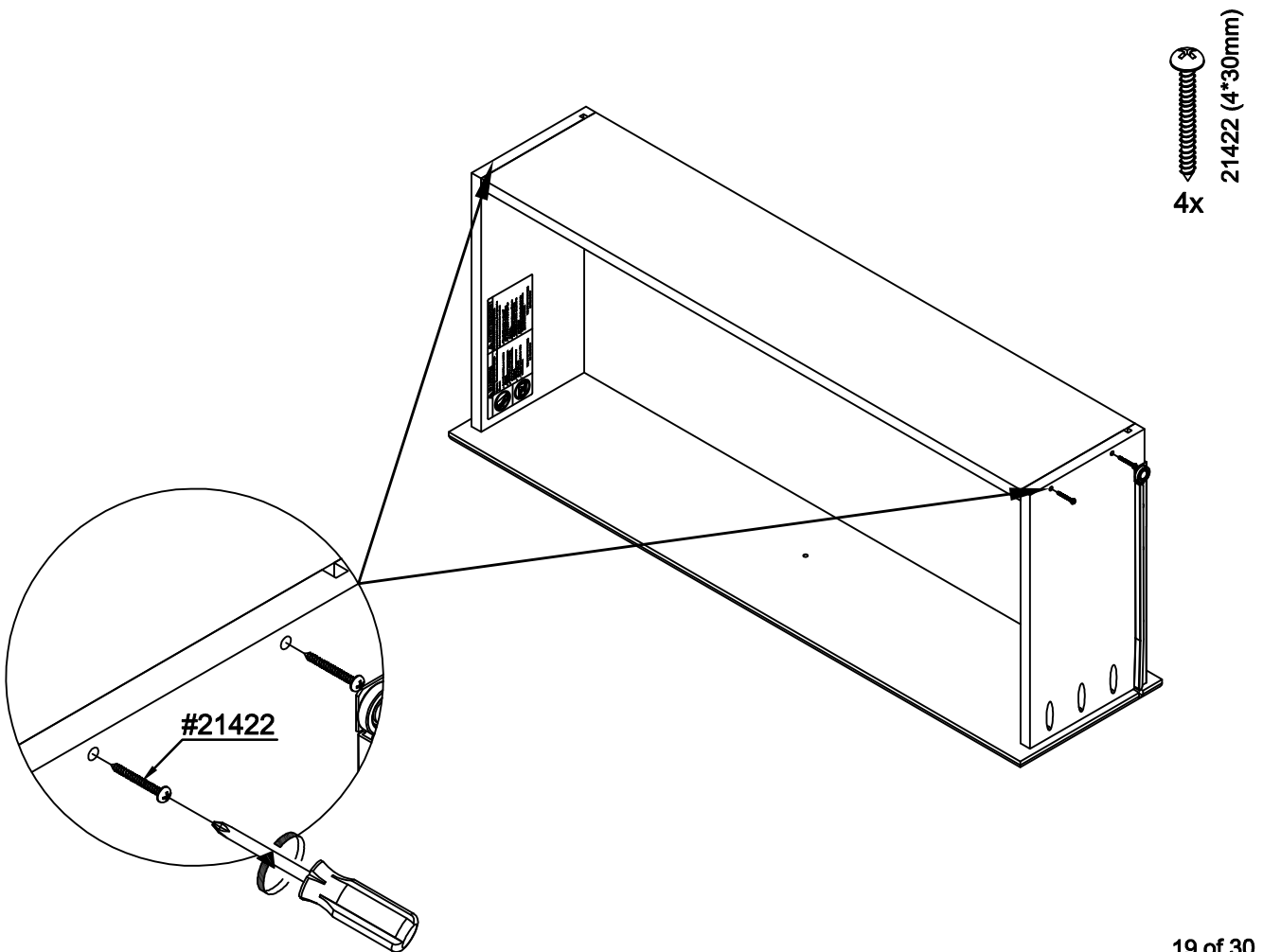
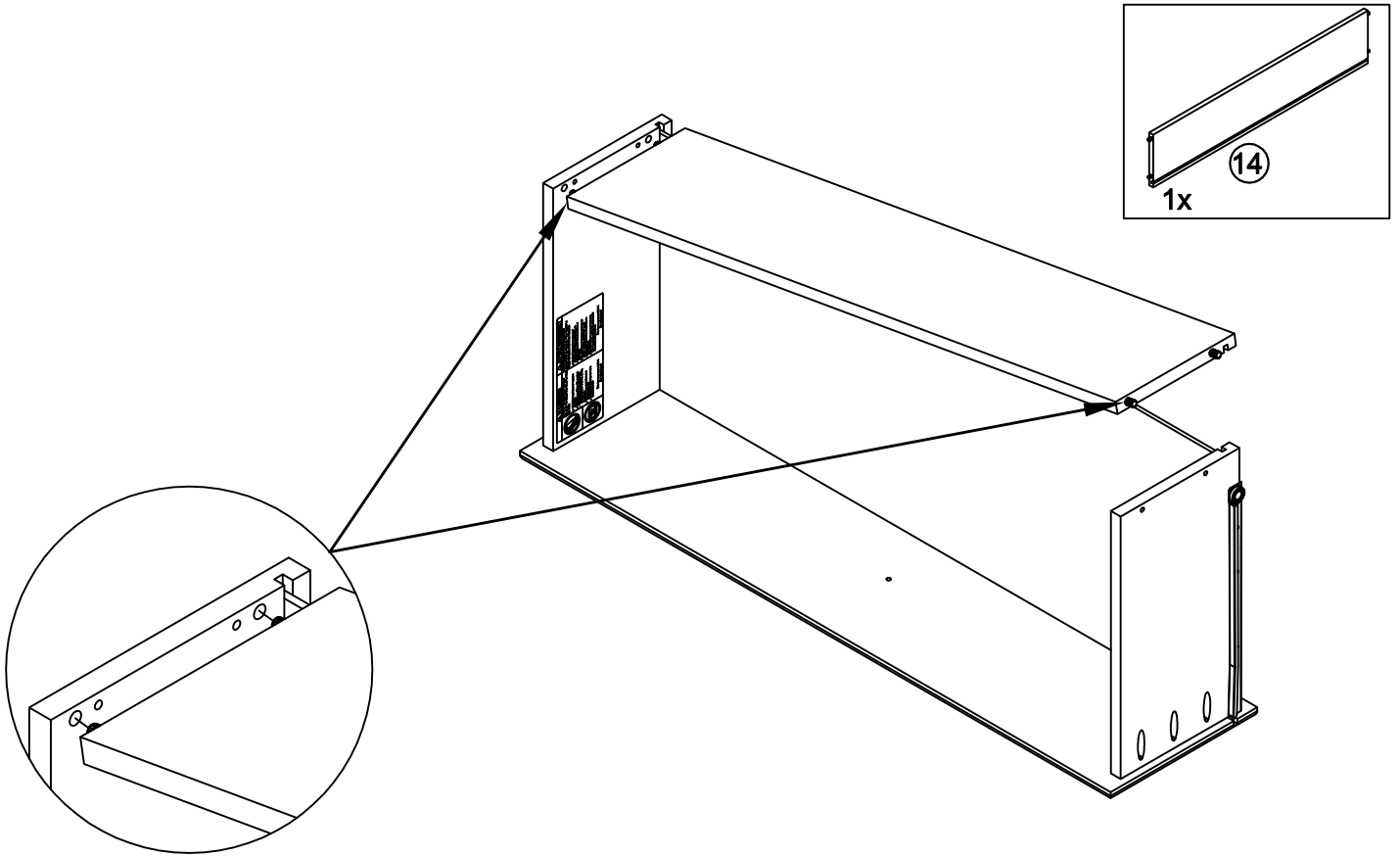

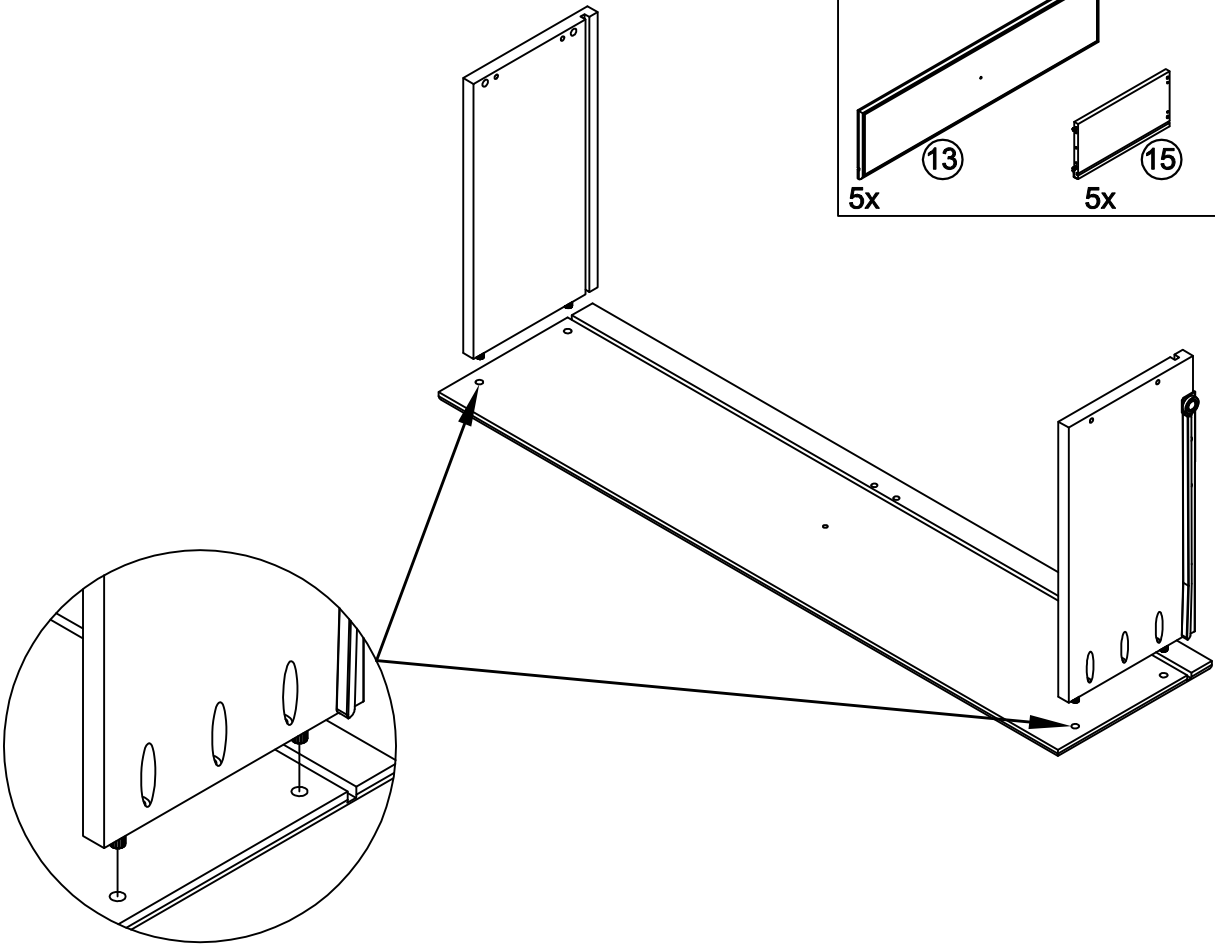
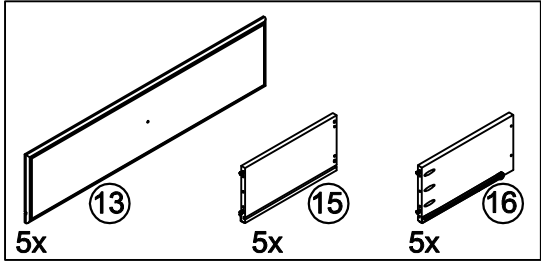

21422 (4*30mm)
30x



The symbol shows a screw with a Phillips head and a threaded shaft.

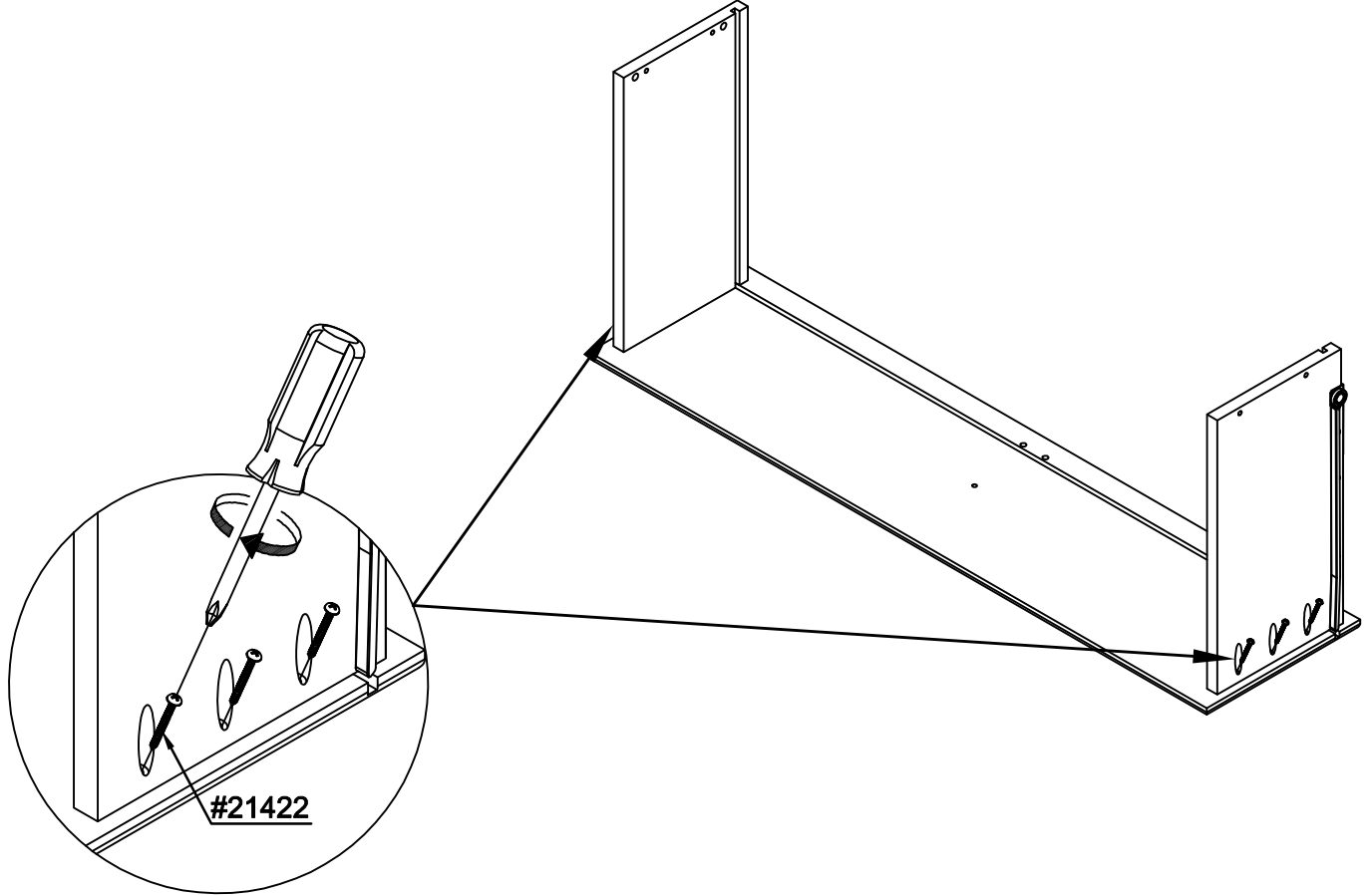

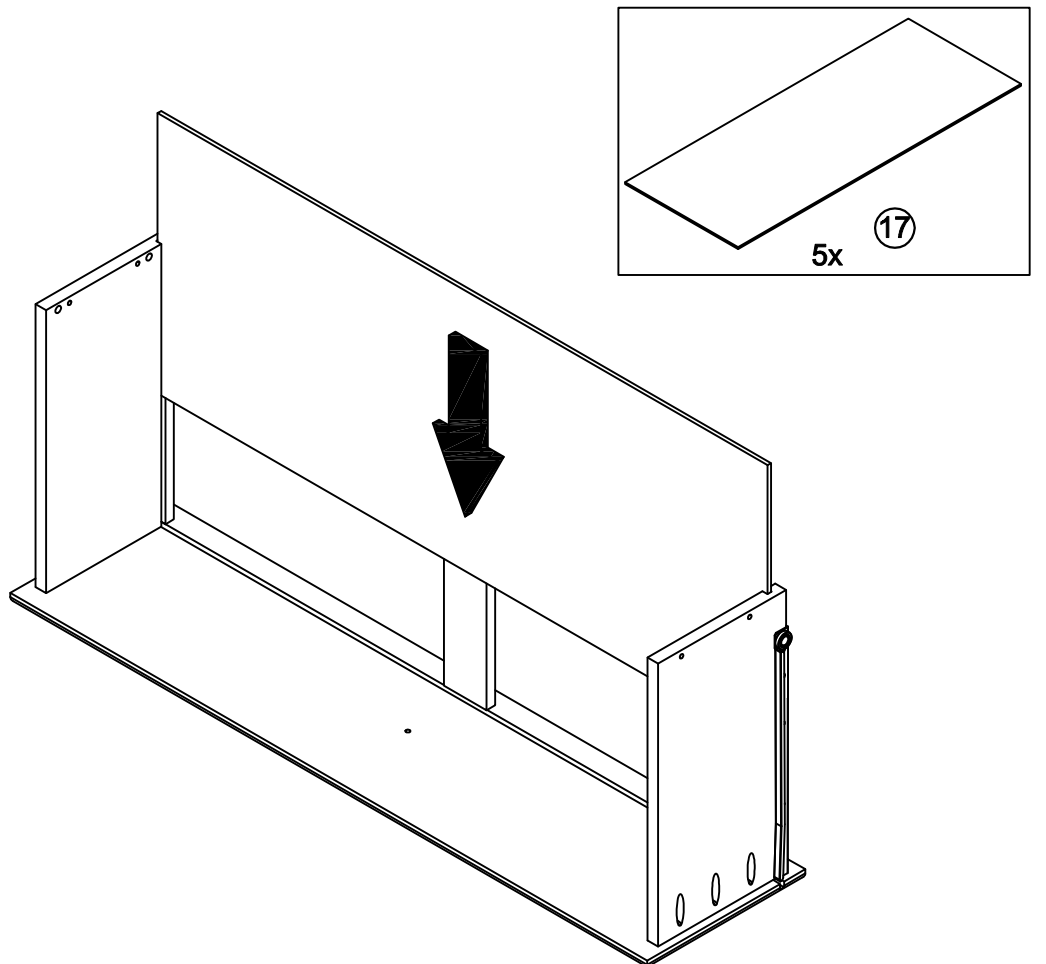
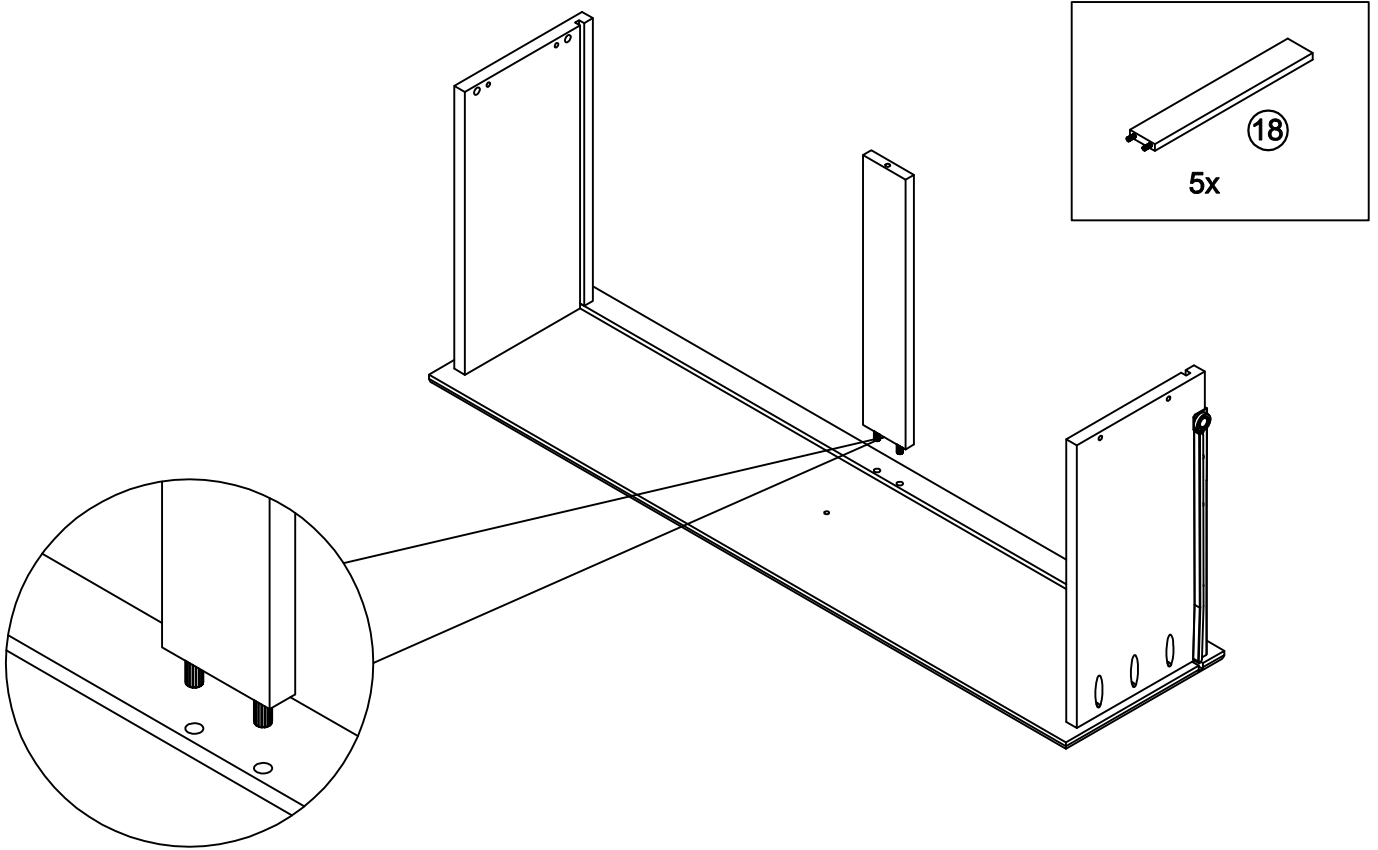

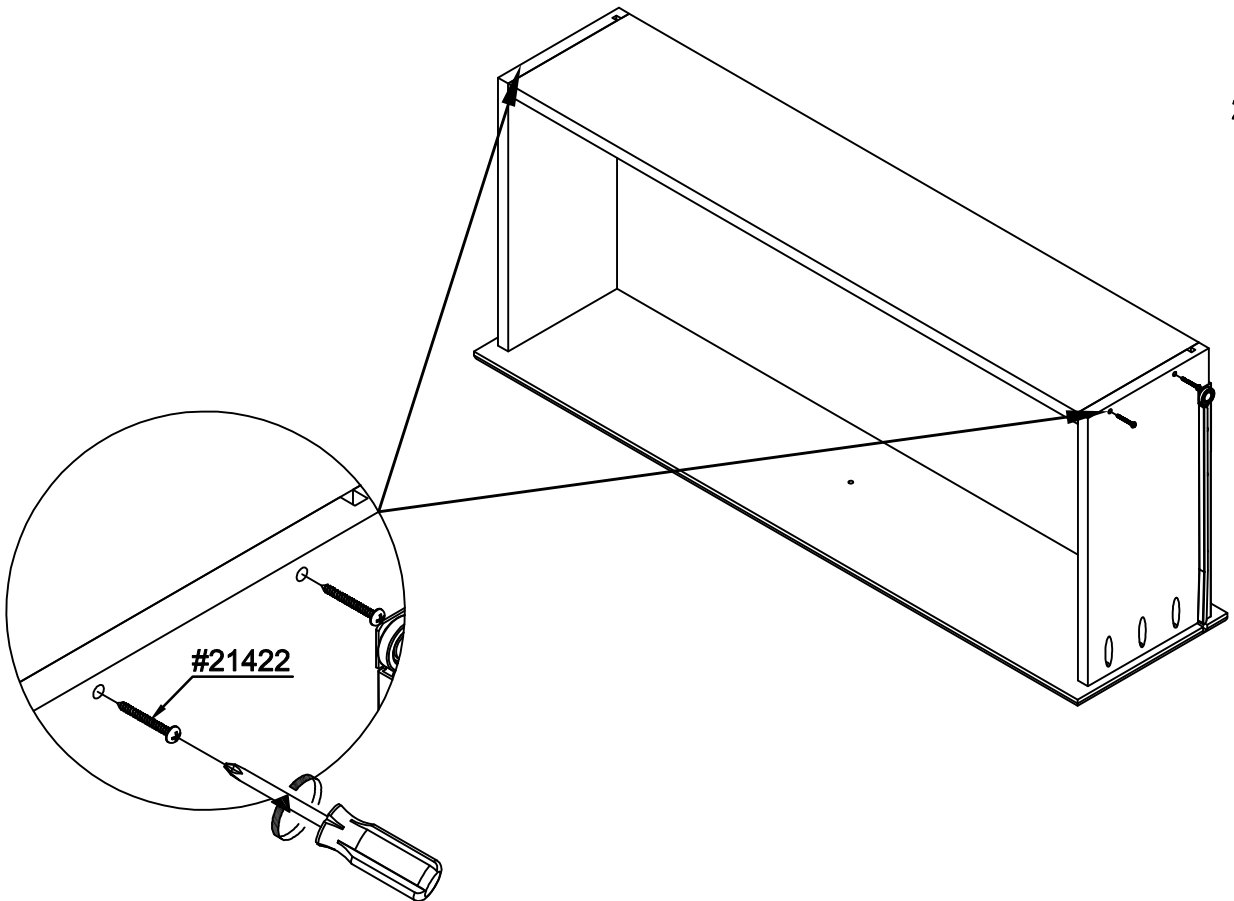
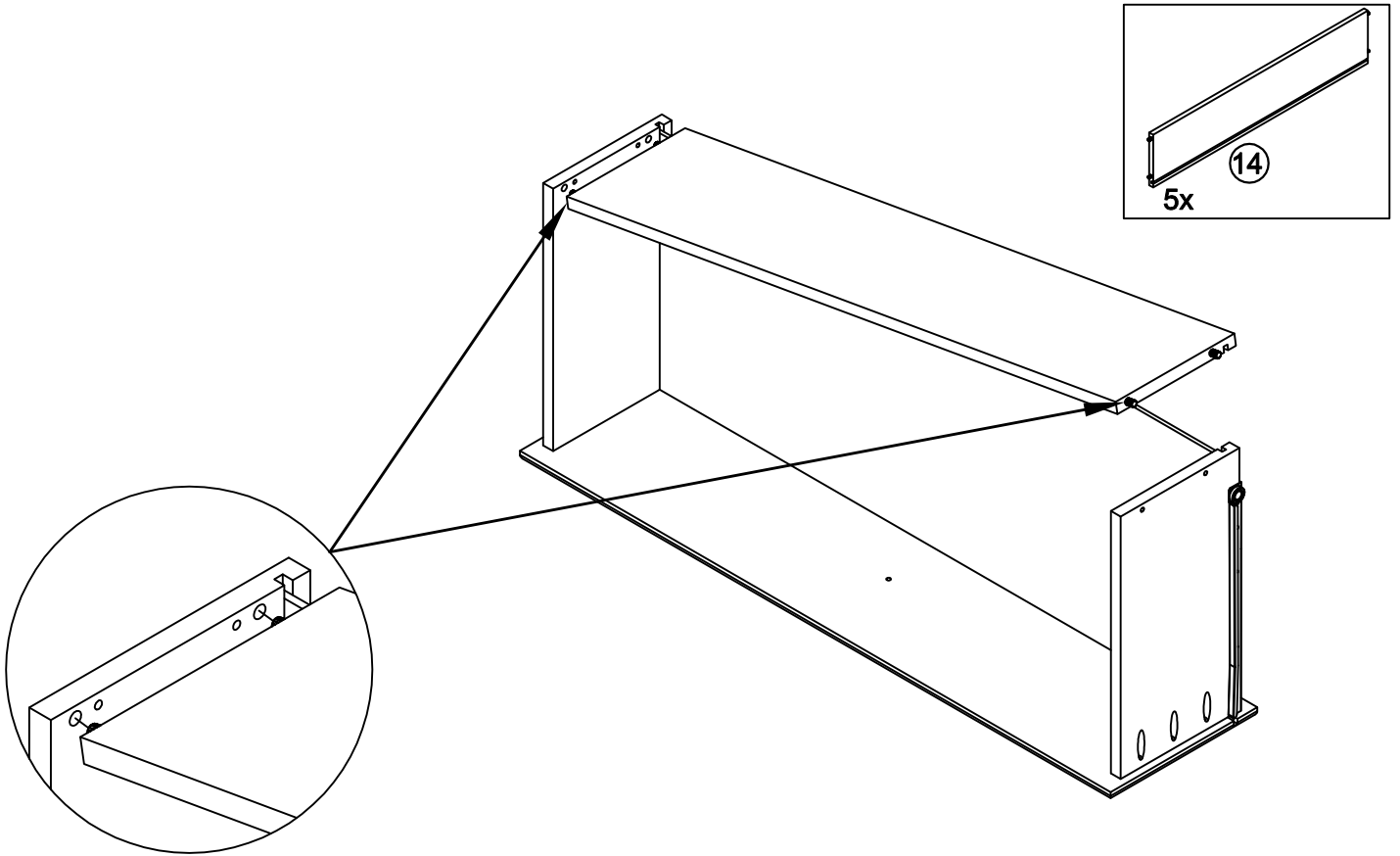

20x
#21422 (4*30mm)

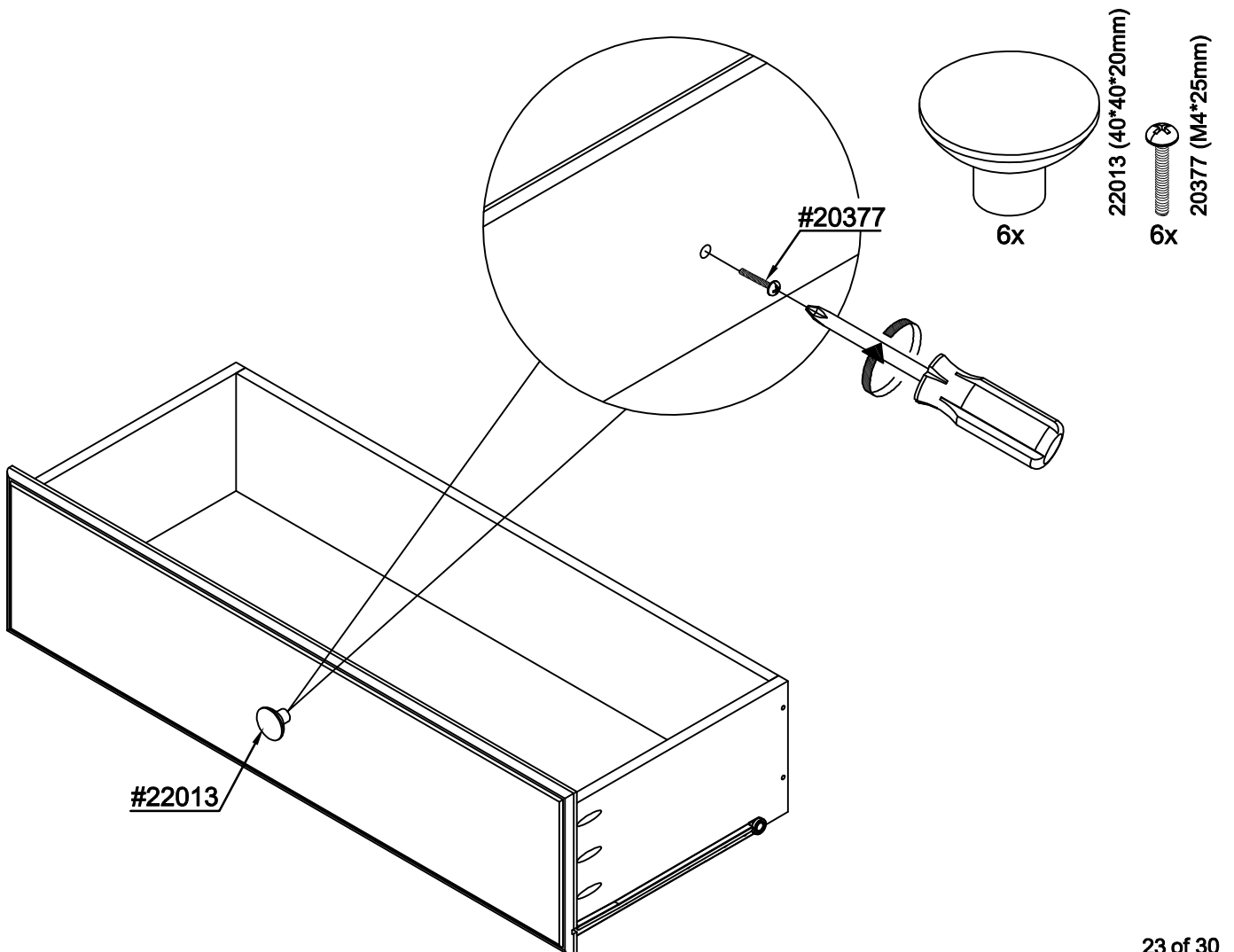
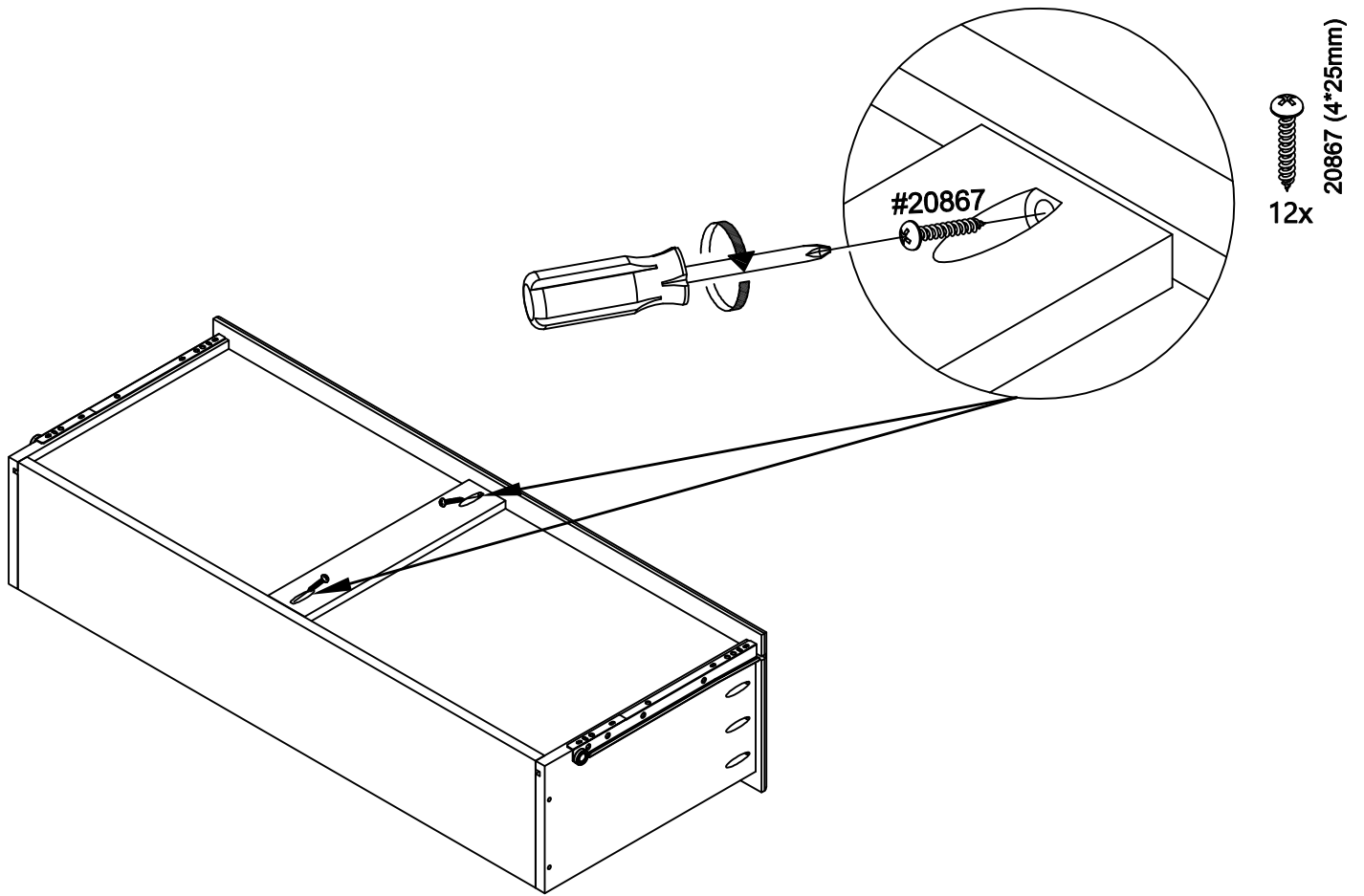

	<p>⚠ WARNING</p> <p>Children have died from furniture tip-over. To reduce the risk of furniture tip-over:</p> <ul style="list-style-type: none"> • ALWAYS install tip-over restraint provided. • NEVER put a TV on this product. • NEVER allow children to stand, climb or hang on drawers, doors, or shelves. • NEVER open more than one drawer at a time. • Place the heaviest items in the lowest drawers. <p><i>This is a permanent label. Do not remove!</i></p>	<p>⚠ AVERTISSEMENT</p> <p>Des enfants sont morts suite à des basculements de meubles. Pour réduire le risque de basculement des meubles:</p> <ul style="list-style-type: none"> • TOUJOURS installer le dispositif de retenue anti-basculement fourni. • NE JAMAIS placer une téléviseur sur ce produit. • Ne JAMAIS permettre aux enfants de se tenir debout, de grimper ou de s'accrocher aux tiroirs, aux portes ou aux étagères. • Ne JAMAIS ouvrir plus d'un tiroir à la fois. • Placez les articles les plus lourds dans les tiroirs inférieurs. <p><i>Ceci est une étiquette permanente. Ne doit pas être retirée!</i></p>
--	---	---

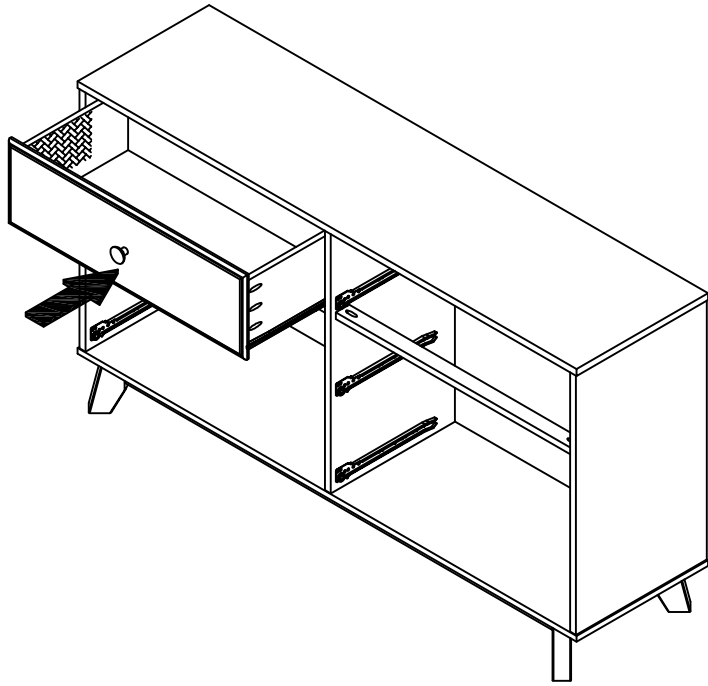
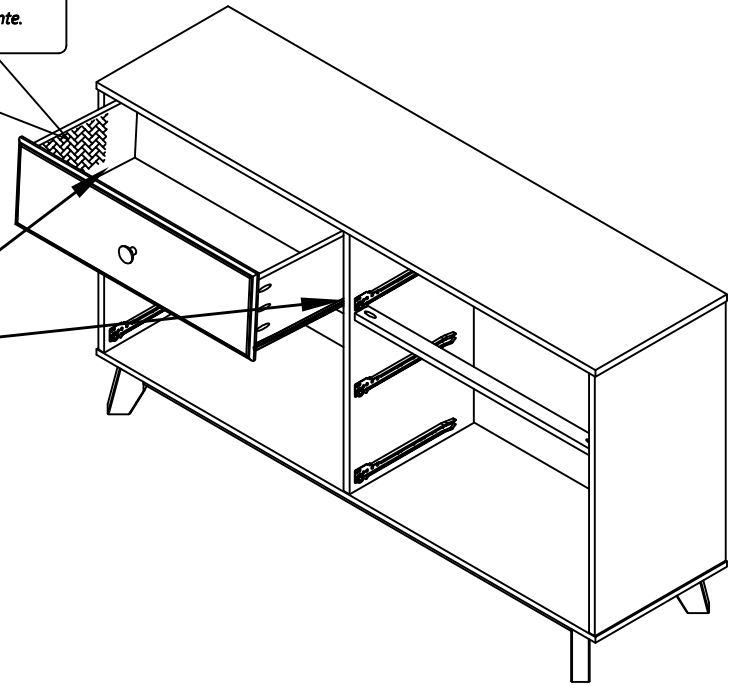
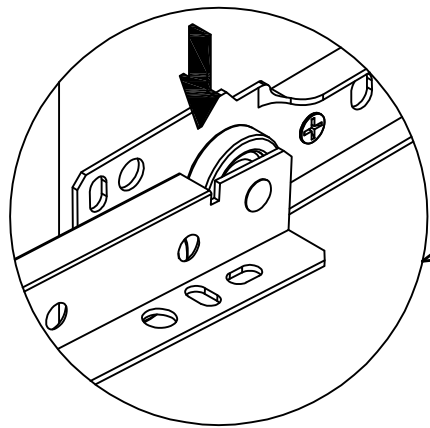

Repeat for all drawers.
 Répéter pour tous les tiroirs.
 Repita para todos los cajones.

Anti-Tip Over Restraint Kit Assembly Instructions

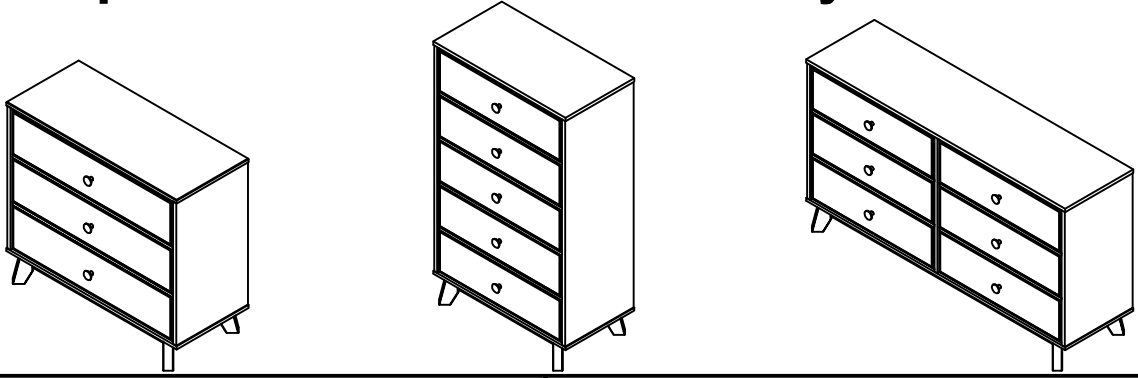

Secure Your Furniture

⚠ WARNING



Children have died from furniture tip-over. To reduce the risk of furniture tip-over:

- ALWAYS install tip-over restraint provided.
- NEVER put a TV on this product.
- NEVER allow children to stand, climb or hang on drawers, doors, or shelves.
- NEVER open more than one drawer at a time.
- Place the heaviest items in the lowest drawers.



Anti-Tip Over Fastening System

- The hardware used to secure your furniture to the wall depends on the material the wall is made of.
- If you are not sure what hardware to use or if you have any questions, consult a hardware retailer.
- Refer to the diagrams on how to anchor your furniture to the wall.
- Ensure furniture bracket is securely attached to the furniture and the cable loop and screw are tightly fastened to the wall.

IMPORTANT, RETAIN FOR FUTURE USE: READ CAREFULLY

**** For the safety of your child, we highly recommend that you install the enclosed anti-tip furniture fastening system.**

Included	Tools Needed	Purpose

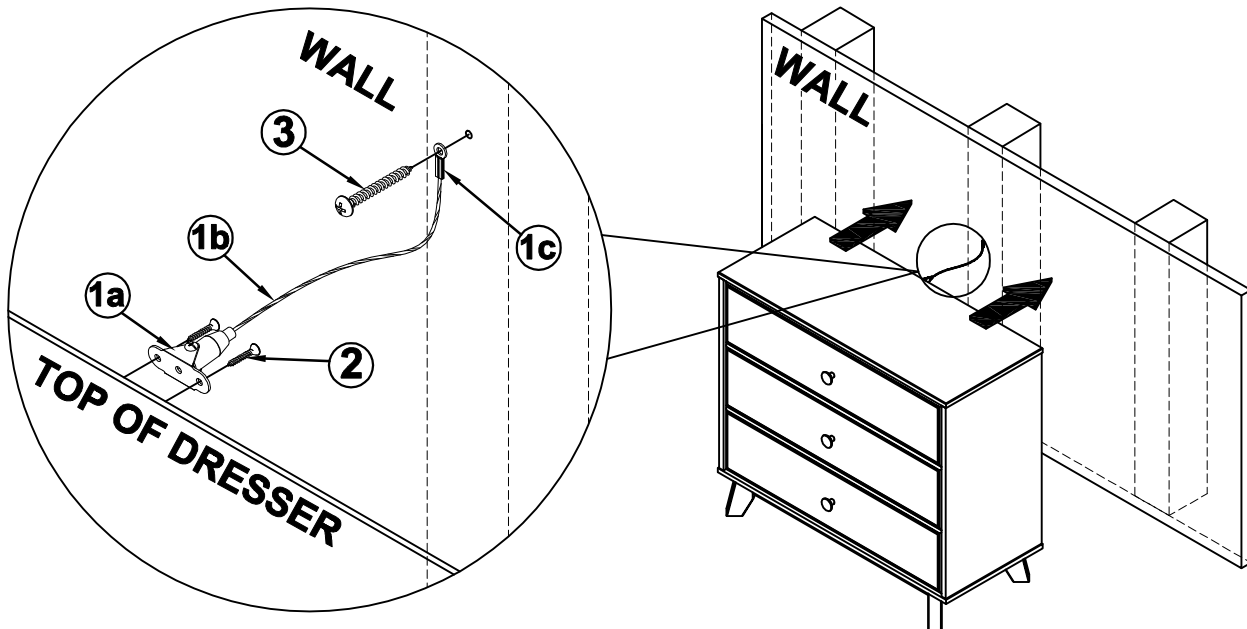

DIRECTIONS

Step 1: Separate cable (1b) from clamp bracket (1a). Push inner ring to unlock clamp.

Step 2: Attach cable clamp bracket (1a) to back of furniture with 3/4" screws (2) using pilot holes located in top of dresser/bookcase.

- Caution: Bracket must be placed in the center of the back edge of the furniture top.
- Caution: Do not attach to the rear dust panel. This panel is not structural and will not support the weight of the furniture in a tipping incident.

Step 3: Use stud finder to identify wall stud closest to center of furniture. Mark stud at height of dresser top.

- Caution: If you are uncertain about stud location, hire a professional.
- Caution: Always use wall stud. Mount each anti tip restraint to separate stud when multiple restraints are used.

Step 4: Thread 2" screw (3) through eye of cable (1c). Screw into stud at height of top of furniture using a drill or screwdriver.

Step 5: Thread cable (1b) through clamp (1a). Ensure cable is straight and not twisted.

Step 6: Pull cable to the side to tighten. Lock into place.

Step 7: Slide furniture back into place. Check security of furniture.

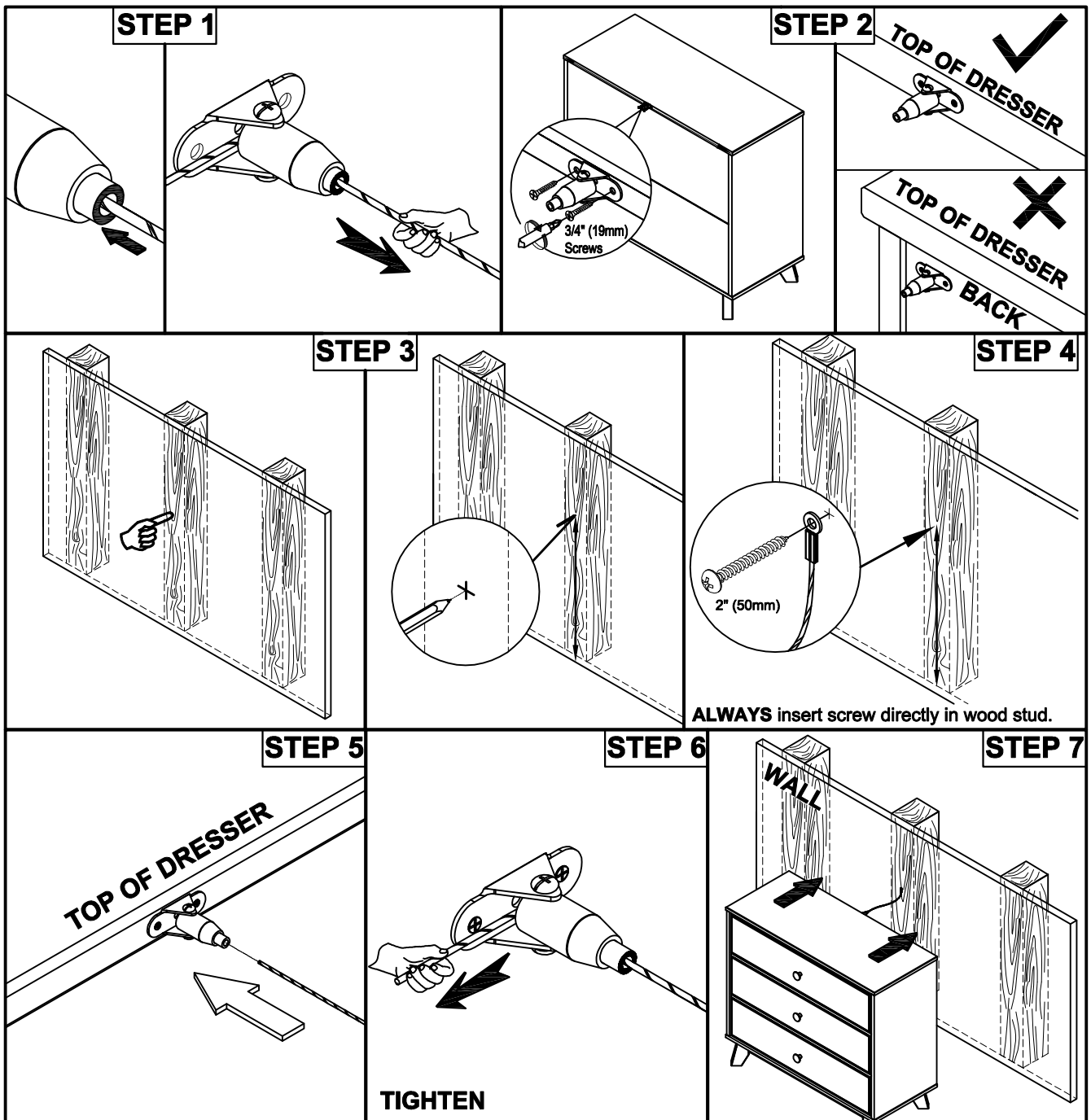

Instructions de montage du kit de retenue anti-basculement



Sécurisez votre mobilier

⚠ AVERTISSEMENT



Des enfants sont morts suite à des basculements de meubles. Pour réduire le risque de basculement des meubles:

- TOUJOURS installer le dispositif de retenue anti-basculement fourni.
- NE JAMAIS placer un téléviseur sur ce produit.
- Ne JAMAIS permettre aux enfants de se tenir debout, de grimper ou de s'accrocher aux tiroirs, aux portes ou aux étagères.
- Ne JAMAIS ouvrir plus d'un tiroir à la fois.
- Placez les articles les plus lourds dans les tiroirs inférieurs.



Système de fixation anti-basculement

- Le matériel utilisé pour fixer vos meubles au mur dépend du matériau dont est fait le mur.
- Si vous n'êtes pas sûr du matériel à utiliser ou si vous avez des questions, consultez un détaillant spécialisé en bricolage.
- Consultez les schémas pour savoir comment ancrer vos meubles au mur.
- Assurez-vous que le support de meuble est bien fixé au meuble et que la boucle de câble et la vis sont bien fixées au mur.

IMPORTANT, À CONSERVER POUR UNE UTILISATION ULTÉRIEURE: LIRE ATTENTIVEMENT

**** Pour la sécurité de votre enfant, nous vous recommandons vivement d'installer le système anti-basculement de fixation des meubles fourni.**

Inclus

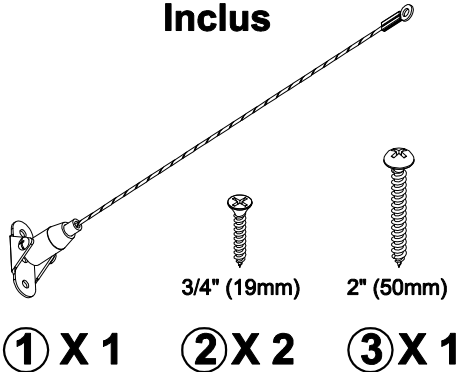

Outils requis

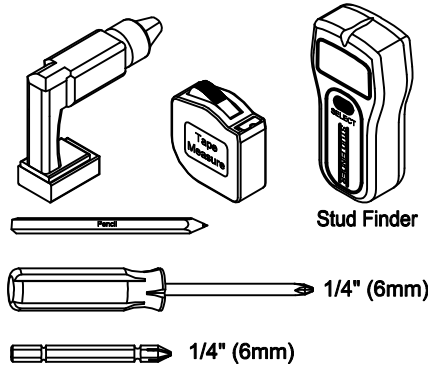

Objectif

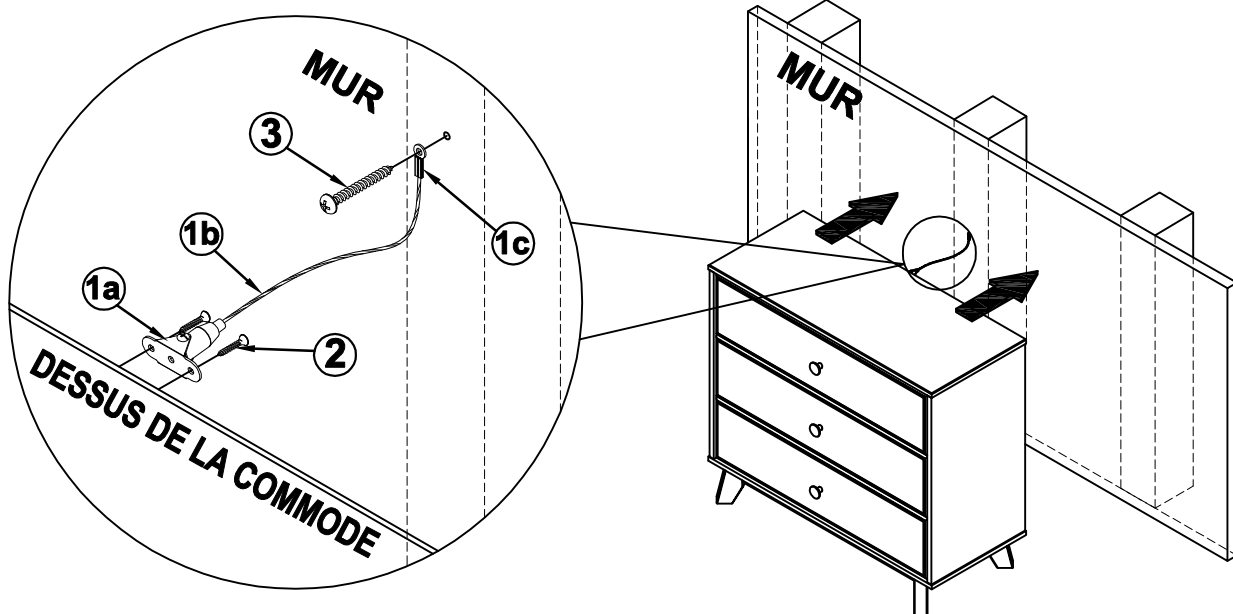
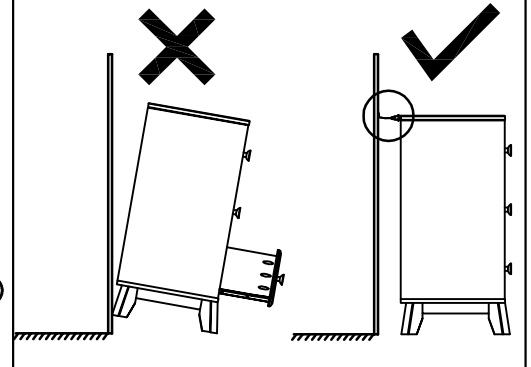

MODE D'EMPLOI

Étape 1: Séparer le câble (1b) du support de fixation (1a). Pousser la bague intérieure pour déverrouiller la fixation.

Étape 2: Fixez le support de fixation du câble (1a) à l'arrière du meuble à l'aide de vis de 3/4" (2) en utilisant les trous pilotes, situés sur le dessus de la commode/étagère.

- Attention: Le support doit être placé au centre du bord arrière du haut du meuble.
- Attention: Ne pas fixer le panneau anti-poussière arrière. Ce panneau n'est pas structurel et ne supportera pas le poids du meuble en cas de basculement.

Étape 3: Utiliser le détecteur de montants pour identifier le montant le plus proche du centre du meuble. Marquer le montant correspondant à la hauteur du haut de la commode.

- Attention: Si vous n'êtes pas sûr de l'emplacement du montant, faites appel à un professionnel.
- Attention: Toujours utiliser un montant mural. Montez chaque dispositif de retenue anti-basculement sur un montant distinct lorsque plusieurs dispositifs de retenue sont utilisés.

Étape 4: Visser la vis 2" (3) dans la boucle de câble (1c). Visser dans le montant à la hauteur du haut du meuble à l'aide d'une perceuse ou d'un tournevis.

Étape 5: Enfilez le câble (1b) dans la fixation (1a). S'assurer que le câble est droit et non entortillé.

Étape 6: Tirez le câble sur le côté pour le serrer. Verrouiller en position.

Étape 7: Remettre les meubles en place. Vérifiez la sécurité des meubles.

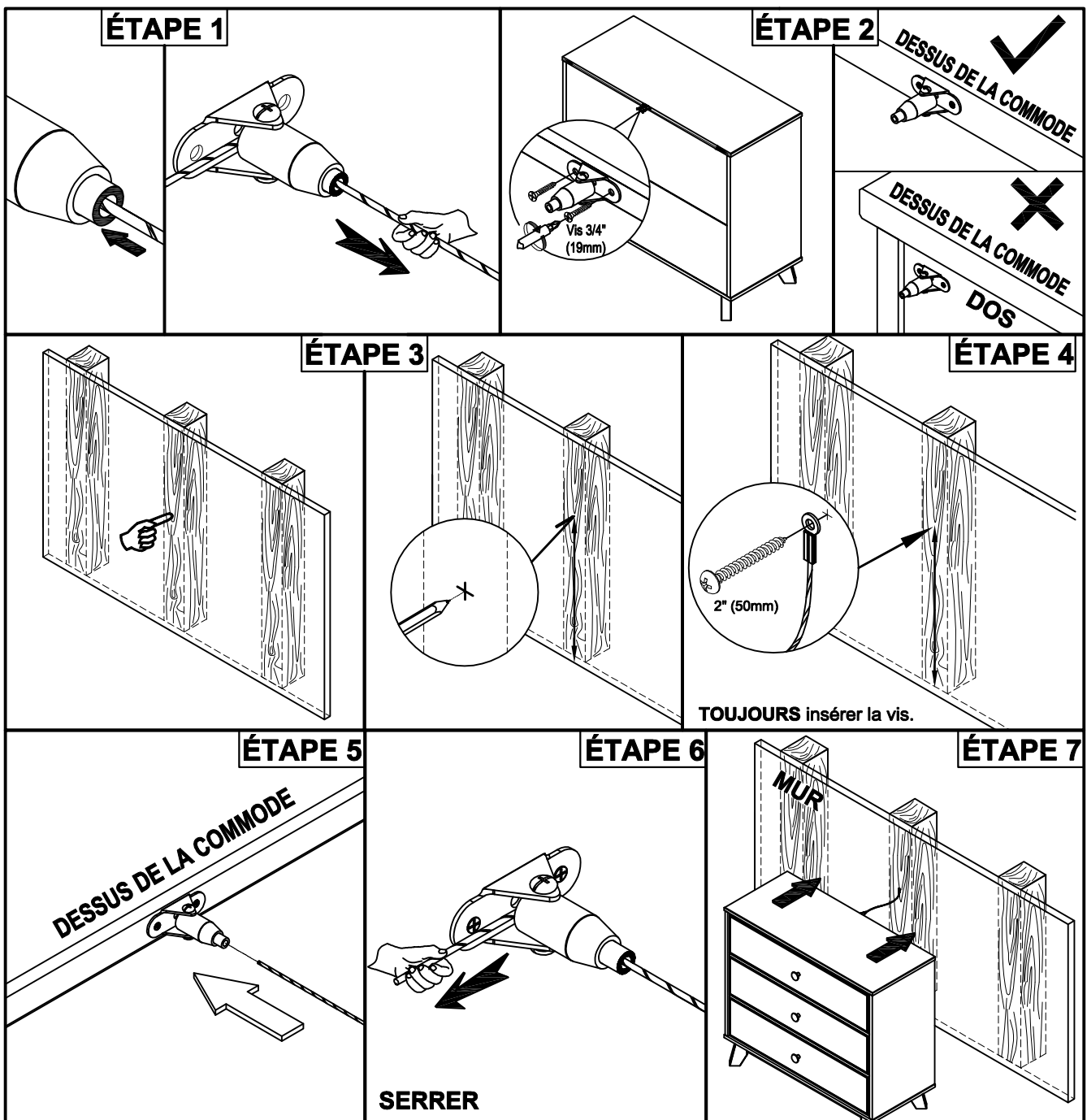

Instrucciones de ensamble del kit de sujeción antivuelco

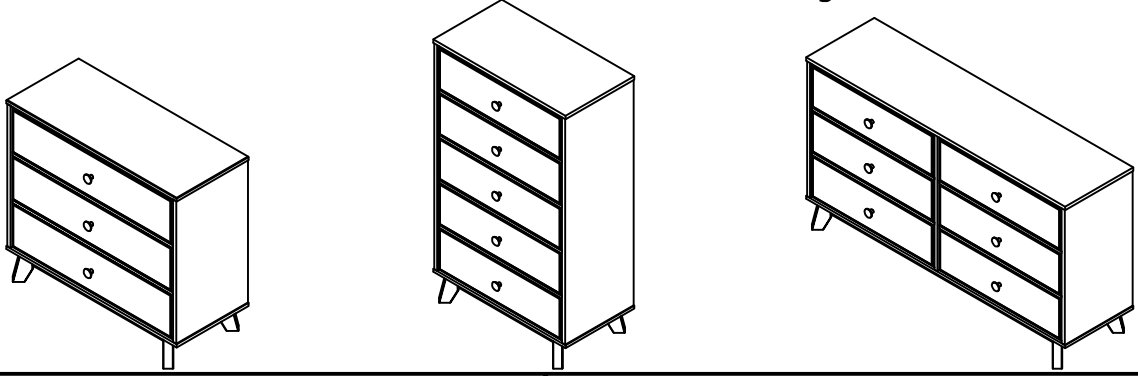

Fije sus muebles

⚠ ADVERTENCIA



Niños han muerto debido a muebles volcados. Para reducir el riesgo de estos accidentes:

- SIEMPRE instale la sujeción antivuelco proporcionada.
- NUNCA coloque una televisión sobre este producto.
- NUNCA permita que los niños se paren, suban o cuelguen de cajones, puertas o estantes.
- NUNCA abra más de un cajón a la vez. Coloque los artículos más pesados en los cajones inferiores.



Sistema de sujeción antivuelco

- Los herrajes usados para fijar sus muebles a la pared dependen del material de la pared.
- Si no está seguro qué herrajes usar, o si tiene preguntas, consulte con un asesor ferretero.
- Consulte los diagramas sobre cómo anclar sus muebles a la pared.
- Asegúrese de que la abrazadera de los muebles esté fijada de manera segura a los muebles, y que el cable de bucle y el tornillo estén bien sujetos a la pared.

IMPORTANTE: GUARDE ESTE DOCUMENTO PARA SU REFERENCIA FUTURA. LÉALO ATENTAMENTE.

**** Por la seguridad de los niños, recomendamos encarecidamente que instale el sistema de sujeción antivuelco incluido**

Incluido	Herramientas necesarias	Propósito
<p>① X 1 ② X 2 ③ X 1</p> <p>3/4" (19mm) 2" (50mm)</p>	<p>Detector de vigas</p> <p>1/4" (6mm)</p> <p>1/4" (6mm)</p>	

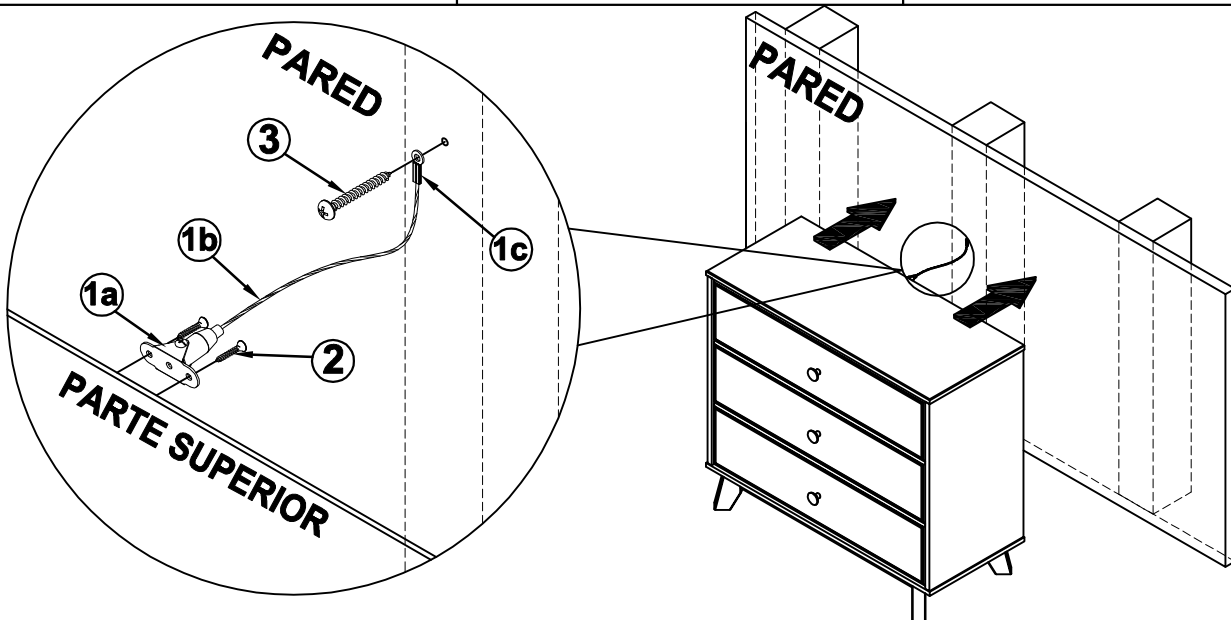

Instrucciones

Paso 1: Separe el cable (1) del soporte de la abrazadera (1a). Presione el anillo interior para desbloquear el soporte.

Paso 2: Fije el soporte de la abrazadera (1a) a la parte posterior del mueble con los tornillos de 3/4" (2) usando los orificios ubicados en la parte superior del peinador/librero.

- Precaución: El soporte debe colocarse en el centro del borde posterior de la parte superior de mueble.
- Precaución: No fije el soporte al panel de polvo posterior. Este panel no es estructural y no resistirá el peso del mueble en caso de vuelco.

Paso 3: Use el detector de vigas para identificar la viga más cercana al centro del mueble. Marque la viga a la altura de la parte superior del mueble.

- Precaución: Si no está seguro de la ubicación de la viga, contrate a un instalador profesional.
- Precaución: Siempre use una viga de pared. Si usa más de una sujeción antivuelco, fije cada una a vigas diferentes.

Paso 4: Pase el tornillo de 2" (3) a través del ojal del cable (1c). Con un desarmador o taladro, atornillelos a la viga a la altura de la parte superior del mueble.

Paso 5: Pase el cable (1b) a través de la abrazadera (1a). Asegúrese de que el cable este recto y no retorcido.

Paso 6: Tire del cable hacia un lado para ajustarlo y bloquearlo en su sitio.

Paso 7: Vuelva a colocar el mueble en su sitio. Asegúrese de que el mueble haya quedado fijo.

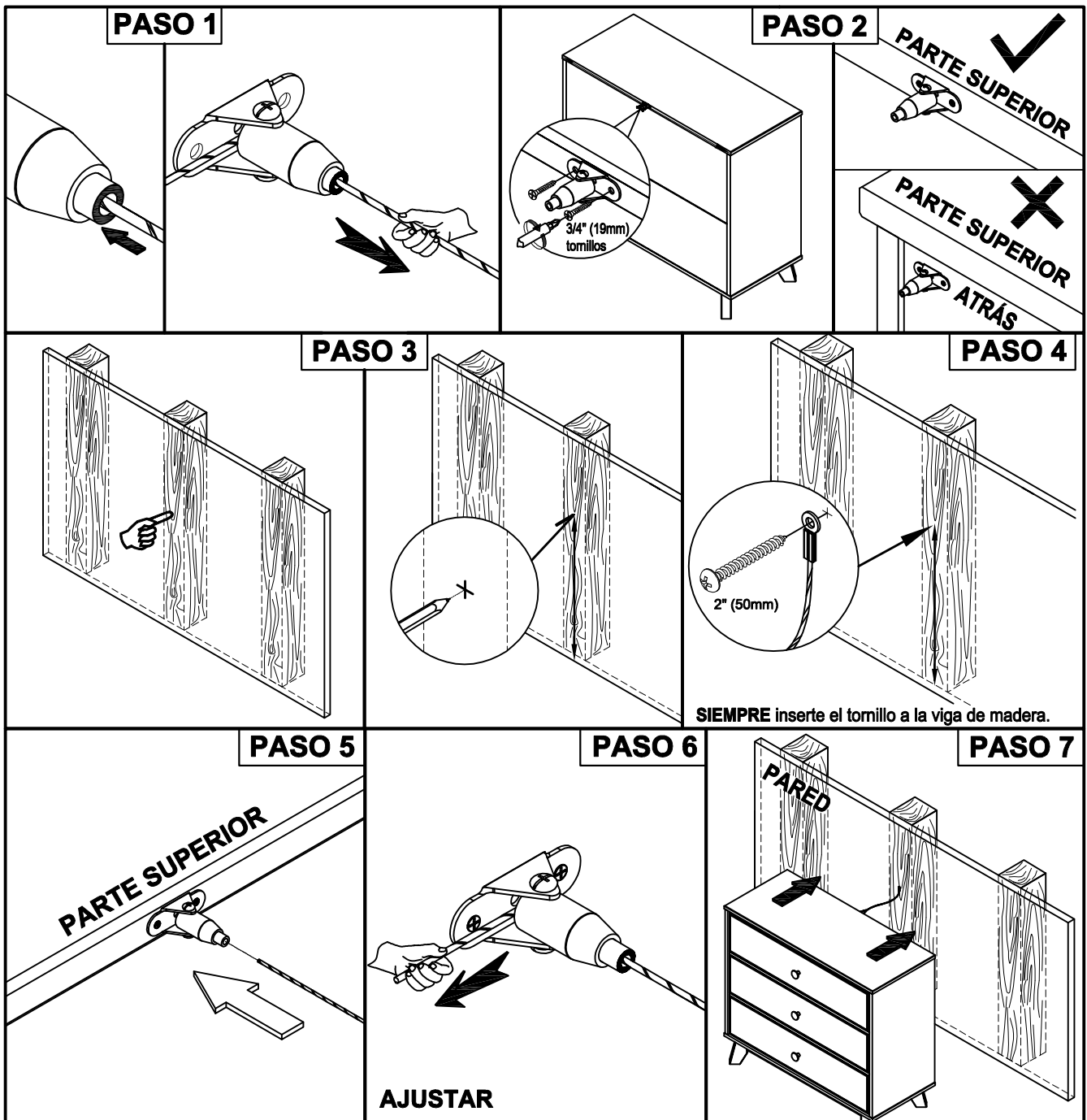

ENGLISH

We hope you and your kids will love it! Please keep these assembly instructions for future reference.

Important:

Safety is our number one concern – please follow these simple safety tips:

Remember to check and tighten bolts/hardware once every few month, as these may loosen with use over time.

Make sure to anchor your large dressers to the wall with the free anti-tip kit provided.

Read and follow the safety instructions on the card attached to the front of your dresser.

Replacement Parts:

In case there is a problem with your product such as missing hardware, please contact your local dealer from whom you purchased the product, and they will be able to provide you with further information on how to obtain replacements.

FRANÇAIS

Nous espérons que vous et vos enfants l'aimeront. Veuillez conserver cette notice de montage pour une consultation ultérieure.

Important :

La sécurité est notre première préoccupation – veuillez suivre ces simples conseils de sécurité :

N'oubliez pas de vérifier et de serrer les boulons/la quincaillerie une fois tous les deux ou trois mois car ces derniers peuvent se desserrer avec le temps.

Assurez-vous d'ancrer vos grosses commodes au mur à l'aide de la trousse anti-basculement fournie.

Pièces de rechange :

En cas de problème avec votre produit comme de la quincaillerie manquante, veuillez contacter le distributeur local à qui vous avez acheté le produit, ce dernier pourra vous fournir plus d'information sur comment obtenir les pièces de rechange.

ESPAÑOL

Esperamos que usted y sus hijos les encantará. Conserve estas instrucciones de montaje para futuras consultas.

Importante:

La seguridad es nuestra preocupación número uno - siga estos sencillos consejos de seguridad:

Recuerde revisar y apretar tornillos / herrajes una vez cada pocos meses, ya que estos pueden aflojarse con el uso a lo largo del tiempo.

Asegúrese de anclar sus aparadores grandes a la pared con el kit anti-tip gratuito proporcionado. Lea y siga las instrucciones de seguridad de la tarjeta colocada en la parte frontal de la cómoda.

Piezas de repuesto:

En caso de que se produzca un problema con el producto, como el hardware faltante, póngase en contacto con

Su distribuidor local de quien adquirió el producto, y ellos podrán proporcionarle más información sobre cómo obtener los reemplazos.