

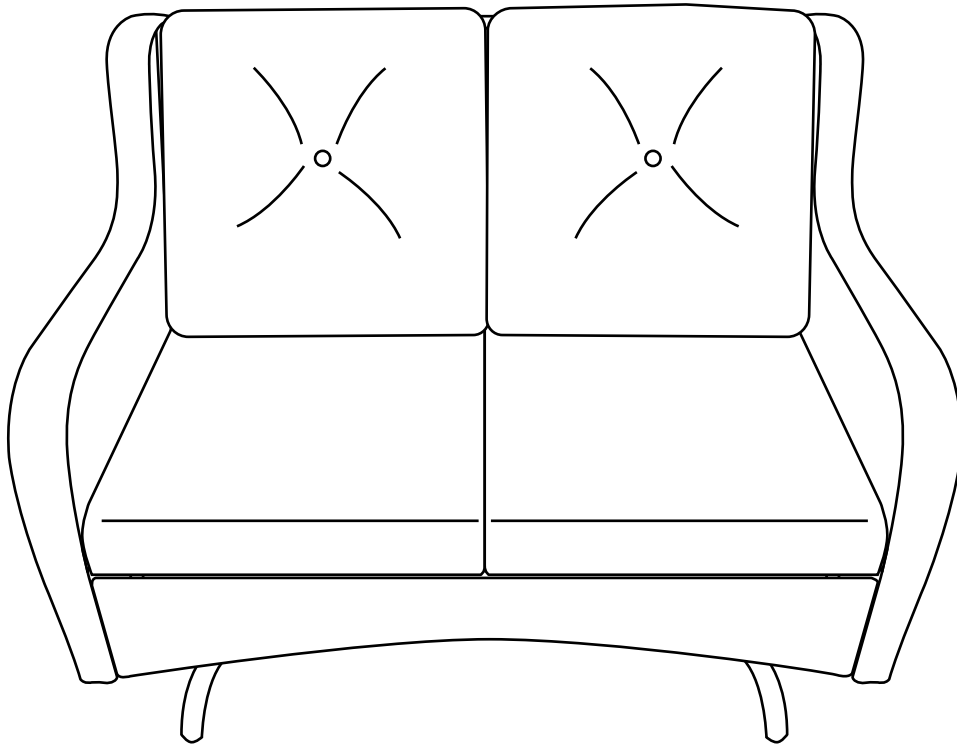







# Assembly Instructions

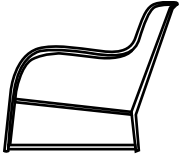
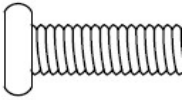
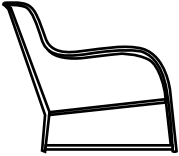
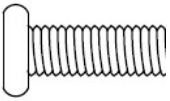

\*Don't fully tighten all the bolts till the very end!

## PRE-ASSEMBLY PREPARATION:

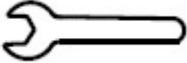
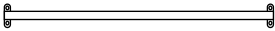
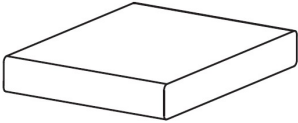
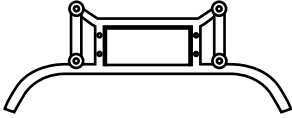
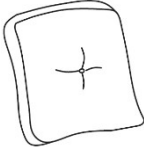
- Please read through the instructions before beginning assembly.
- Clear out the space for assembly and lay out all of the parts based on the Parts List, extra room will allow you to easily determine if all the pieces are present.
- Keep small parts and pieces away from children until fully assembled.

Part no.	Part	QTY	Image	Part no.	Part	QTY	Image
A1	Left arm	1		H	Bolt (M6*40mm)	4	
A2	Right arm	1		I	Bolt (M6*35 mm)	24	
B	Back	1		J	Nut M6	12	
C	Front panel	1		K	Washer M6	24	
D	Seat panel	2		L	Wrench	1	
E	Connecting rod	2		M	Seat cushion	2	
F	Foot stand with swing arm	2		N	Back cushion	2	
G	Allen wrench	1					

**Step 1:** Attach arms A1&A2 to back B with 4pcs bolts I and 4pcs washers K, using Allen wrench G. Note: Don't fully tighten the bolts.

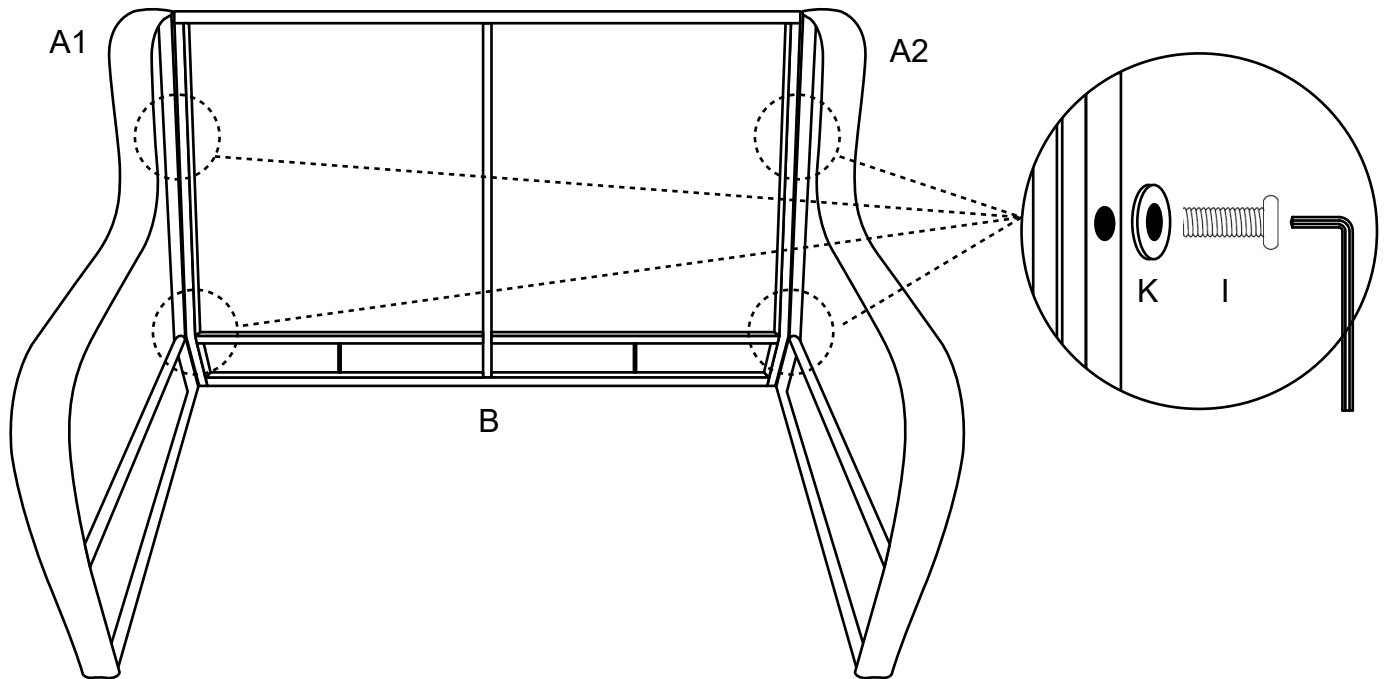

**Step 2:** Attach front panel C to arms A1&A2 with 4pcs bolts I and 4pcs washers K, using Allen wrench G. Note: Don't fully tighten the bolts.

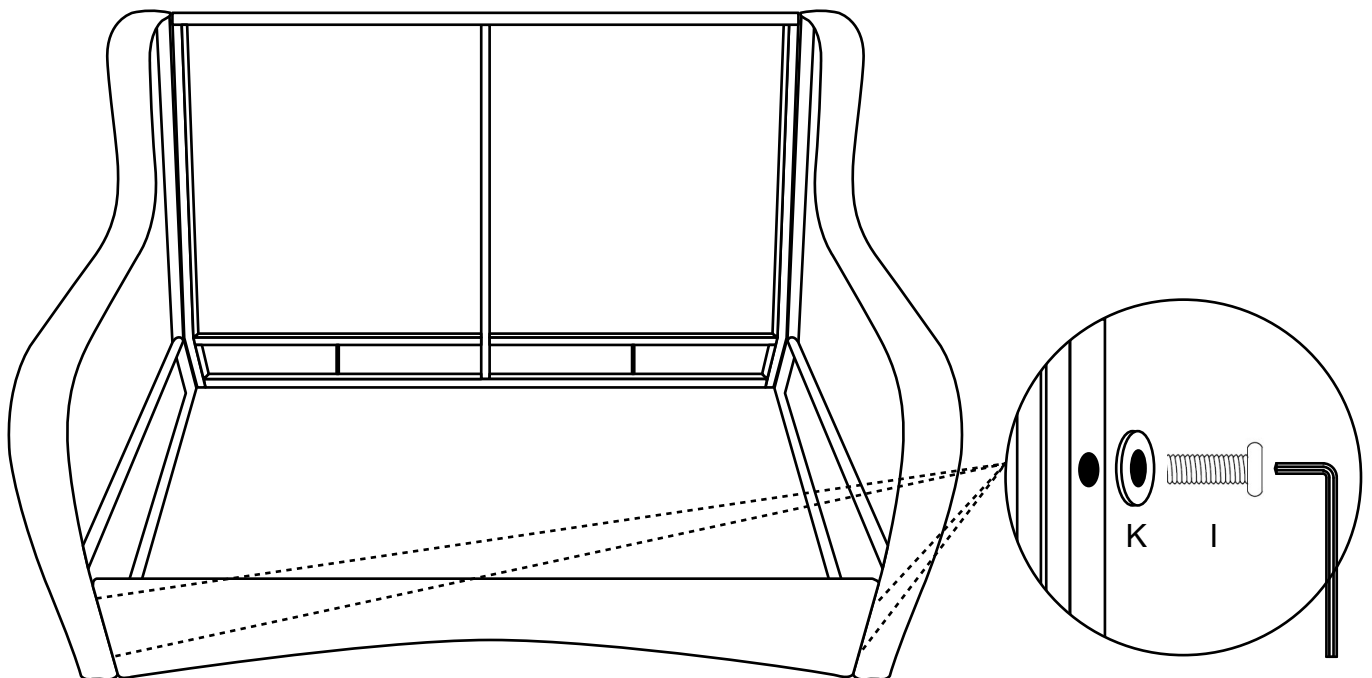

**Step 3:** Attach seat D to back B with 8pcs bolts I and 8pcs washers K, using Allen wrench G. Note: Don't fully tighten the bolts.

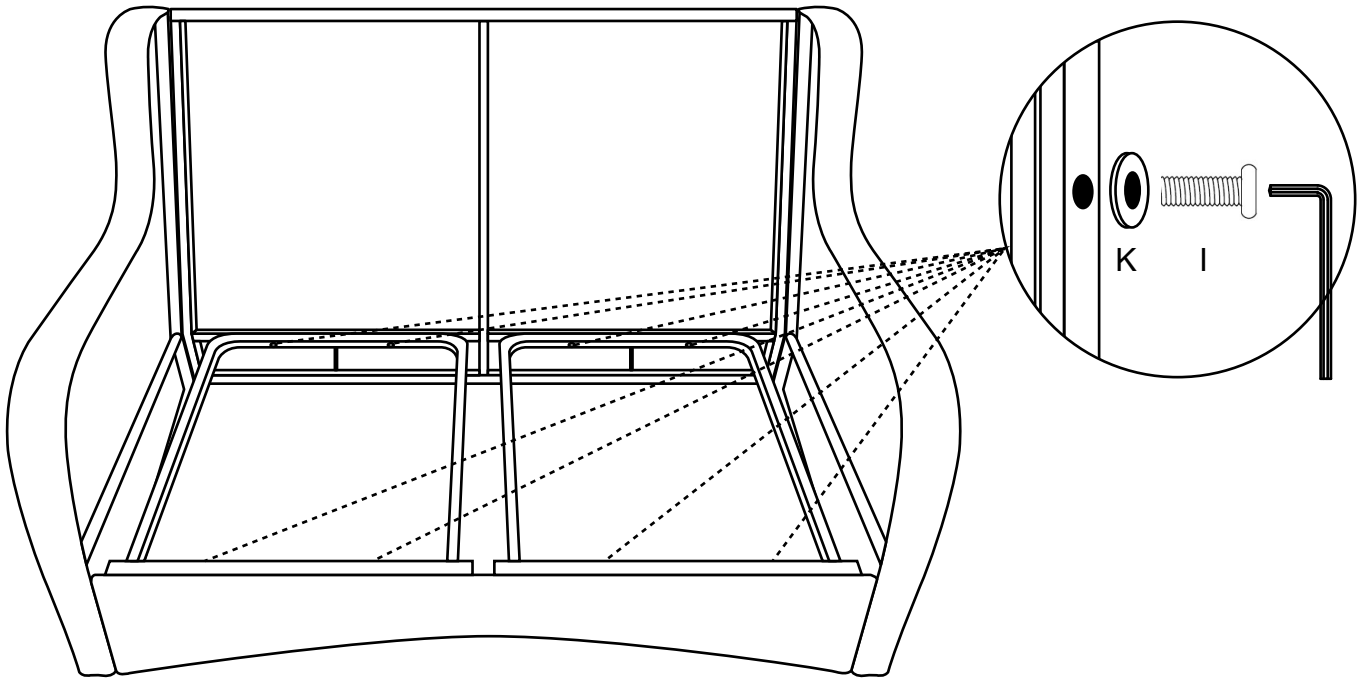

**Step 4:** Attach 2pcs connecting rod E to 2pcs foot stands F with 4pcs bolts I, 4pcs washers K and 4pcs nuts J, using Allen wrench G and wrench L. Note: Don't fully tighten the bolts.

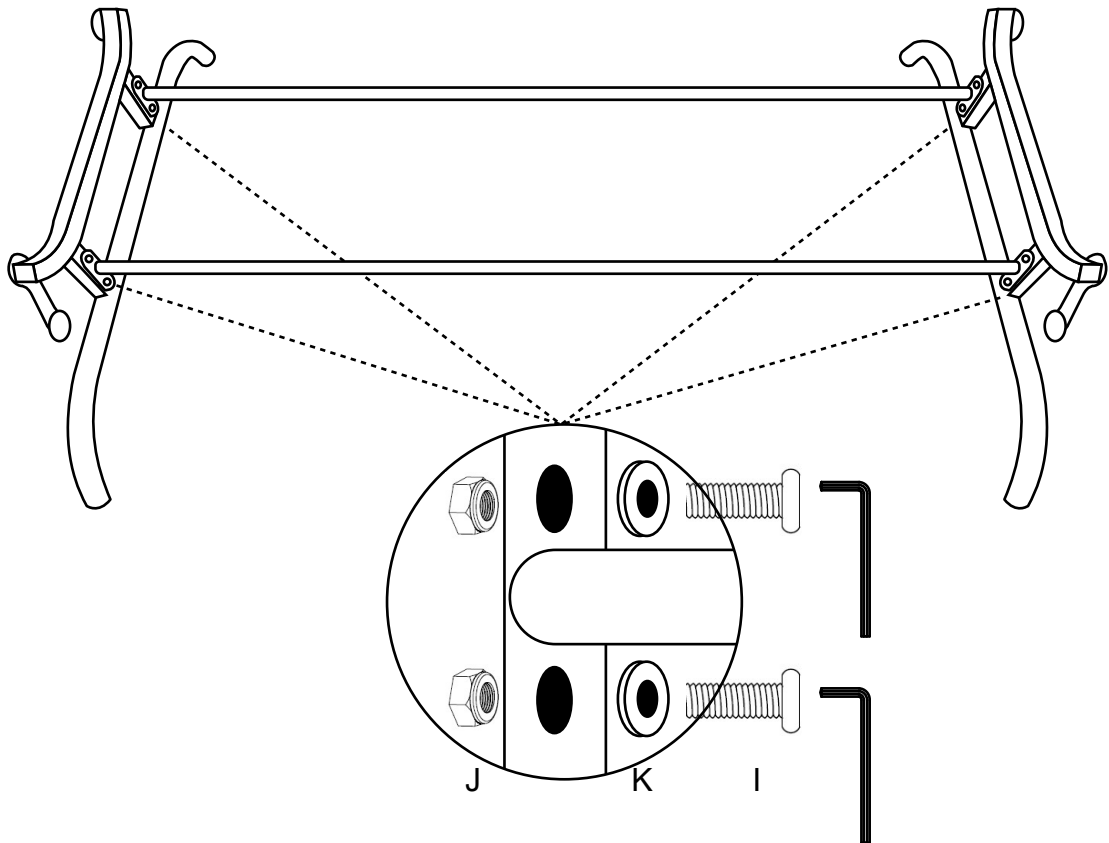

**Step 5:** Attach swing arms to arms A1&A2 with 4pcs bolts H, 4pcs washers K and 4pcs nuts J, using Allen wrench G and wrench L. Note: Don't fully tighten the bolts until they are locked.

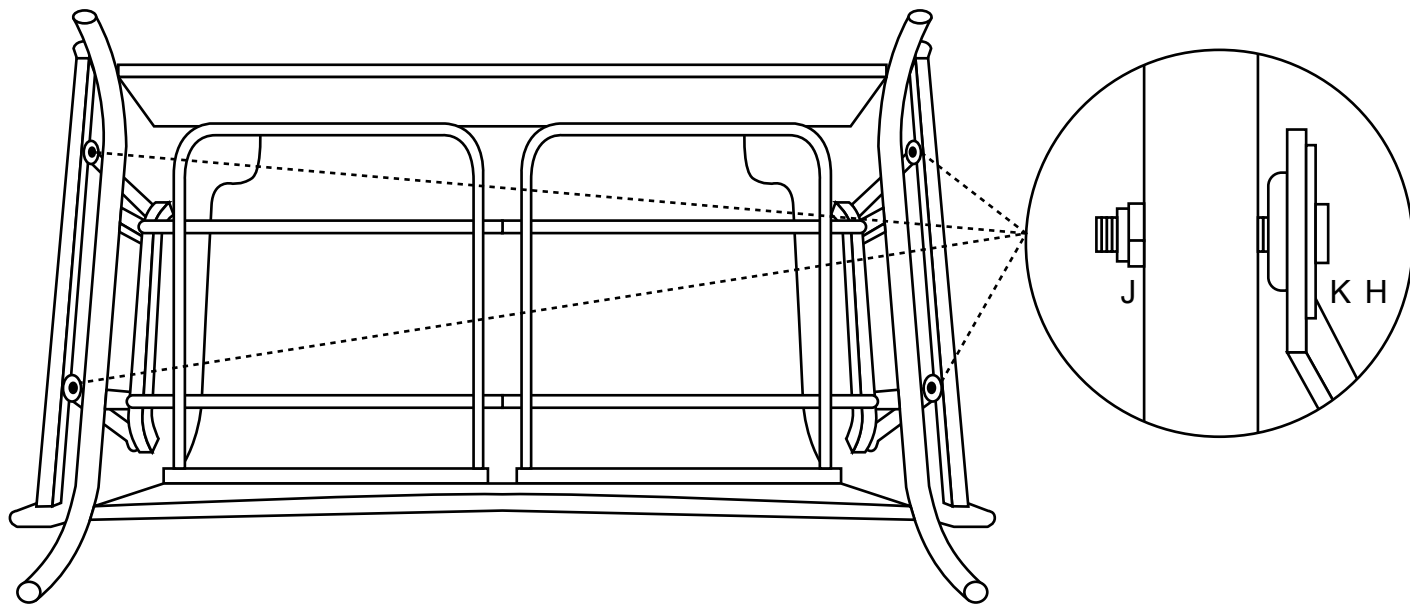

**Step 6:** Put back cushions N and seat cushions M onto the seat . Assembly is now complete and the product is ready for use.

