

BS-2409

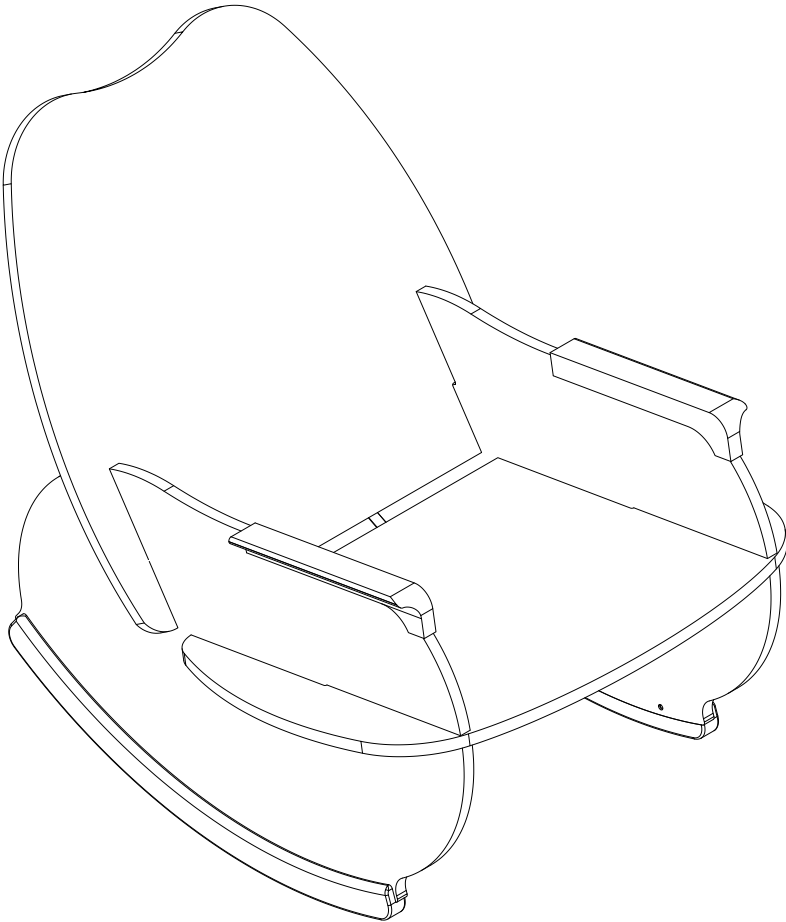

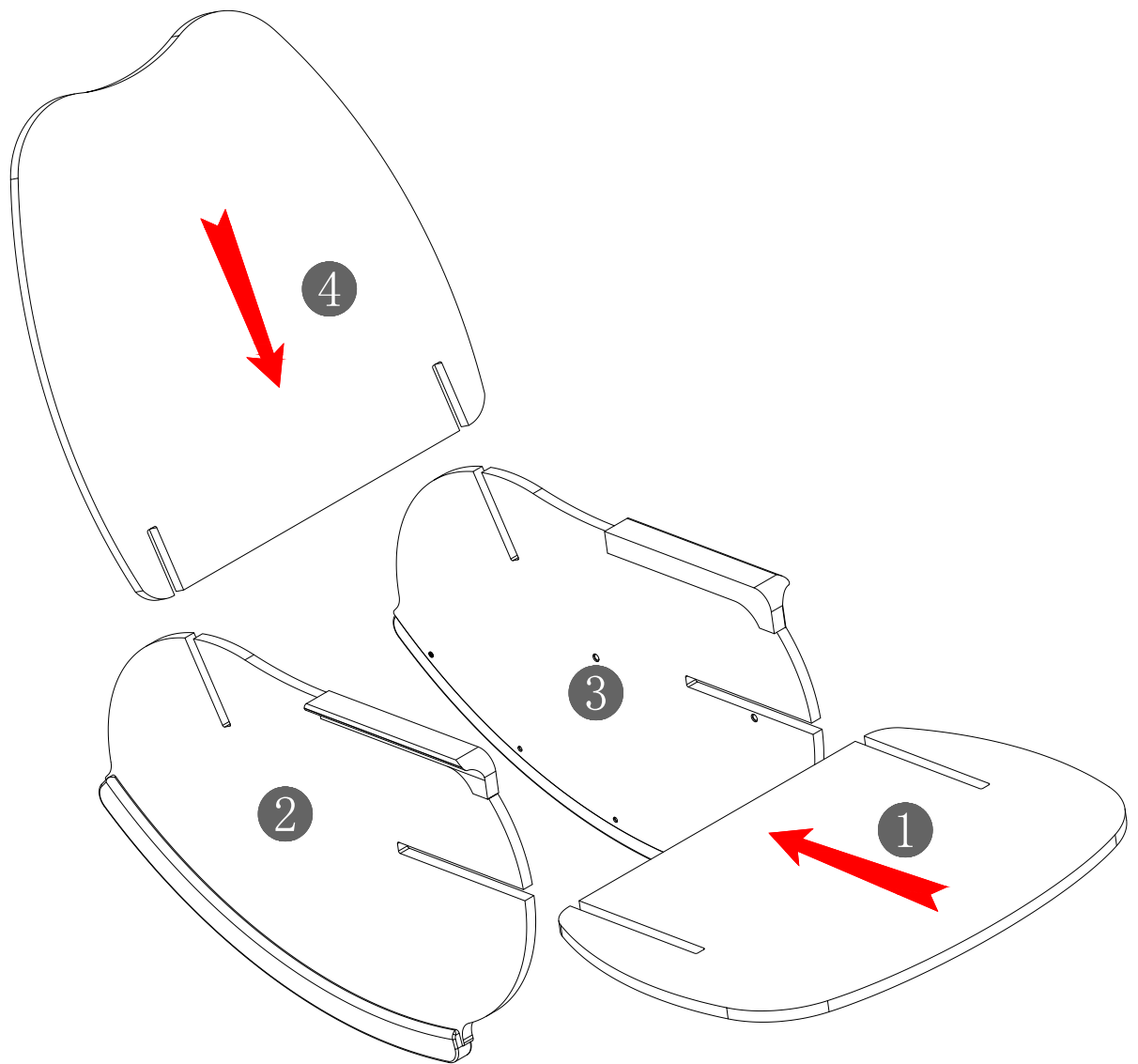

PARTS LIST

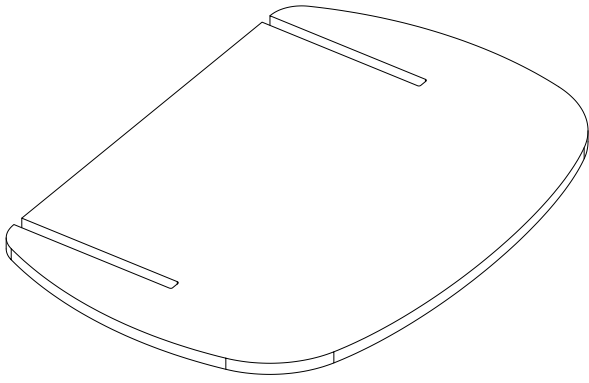

1 X1

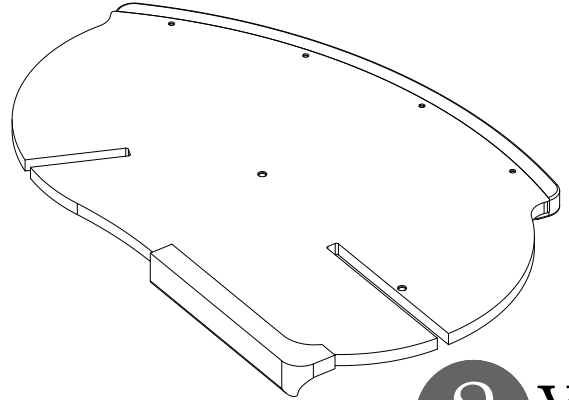

2 X1

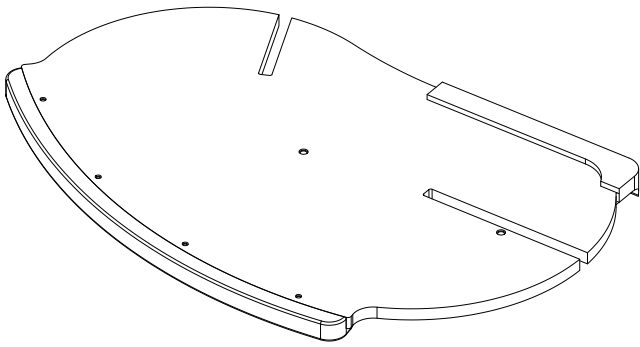

3 X1

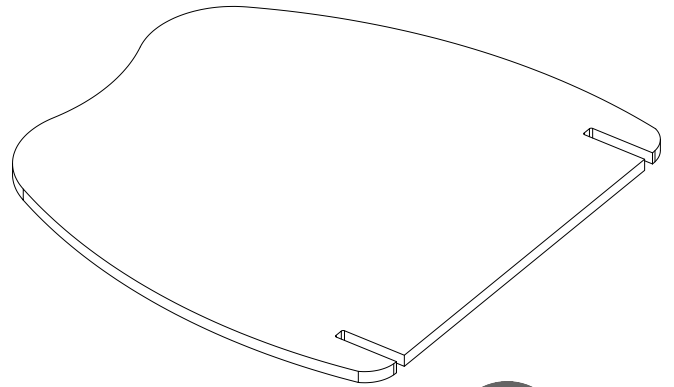

4 X1

BS-2409

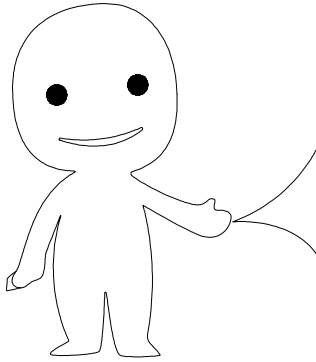

Please prepare the following tools

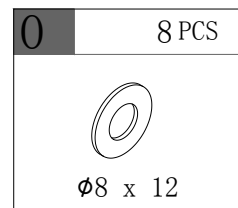
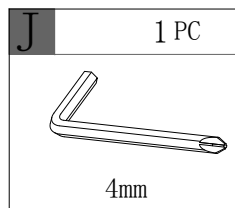
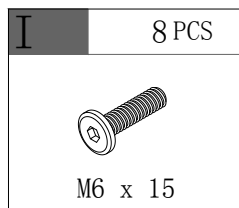
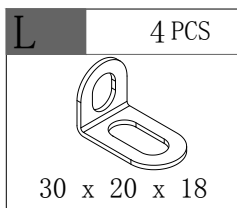
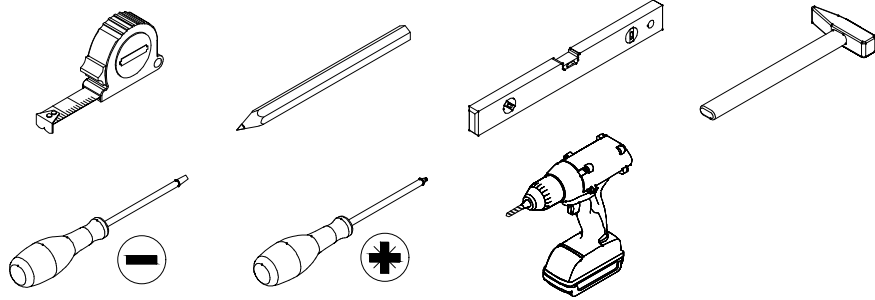

Tips: The number after "+" represents the spare hardware.

Cam Lock/Dowel Placement Supplement

<p>CORRECT</p> <p>1</p> <p>When inserting the Cam lock, make sure that the open End of the cam Lock faces the Cam Screw Entry. The Dowel will be inserted in the hole NEXT to the Cam Lock/Cam Screw hole.</p>	<p>INCORRECT</p> <p>2</p> <p>The Cam Lock is backwards in this illustration. The Cam Screw can not connect to the Cam Lock because the Dowel is in the incorrect hole.</p>	<p>3</p> <p>To tighten, turn the Cam Lock CLOCKWISE until the arrow or "△" signs point AWAY from the connected Panel.</p> <p>*NOTE: DO NOT USE AN AUTOMATIC SCREWDRIVER TO TIGHTEN CAM LOCKS, DO NOT OVER-TIGHTEN.</p>
---	---	---

1

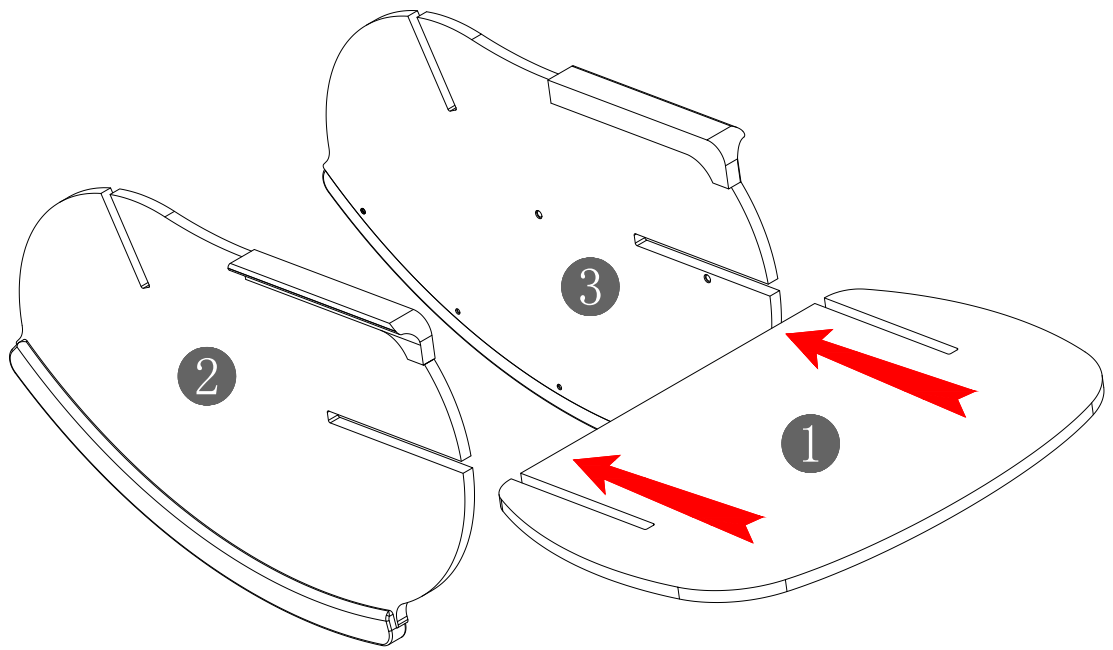

2

